

Notes:

1. Follow all manufacturer's instructions for installation

2. Condensate gutters are a means of collecting and expelling condensation water; they are not well configured to control bulk water intrusion through faulty weather seals and should not be relied upon to function as such unless specifically designed to do so.

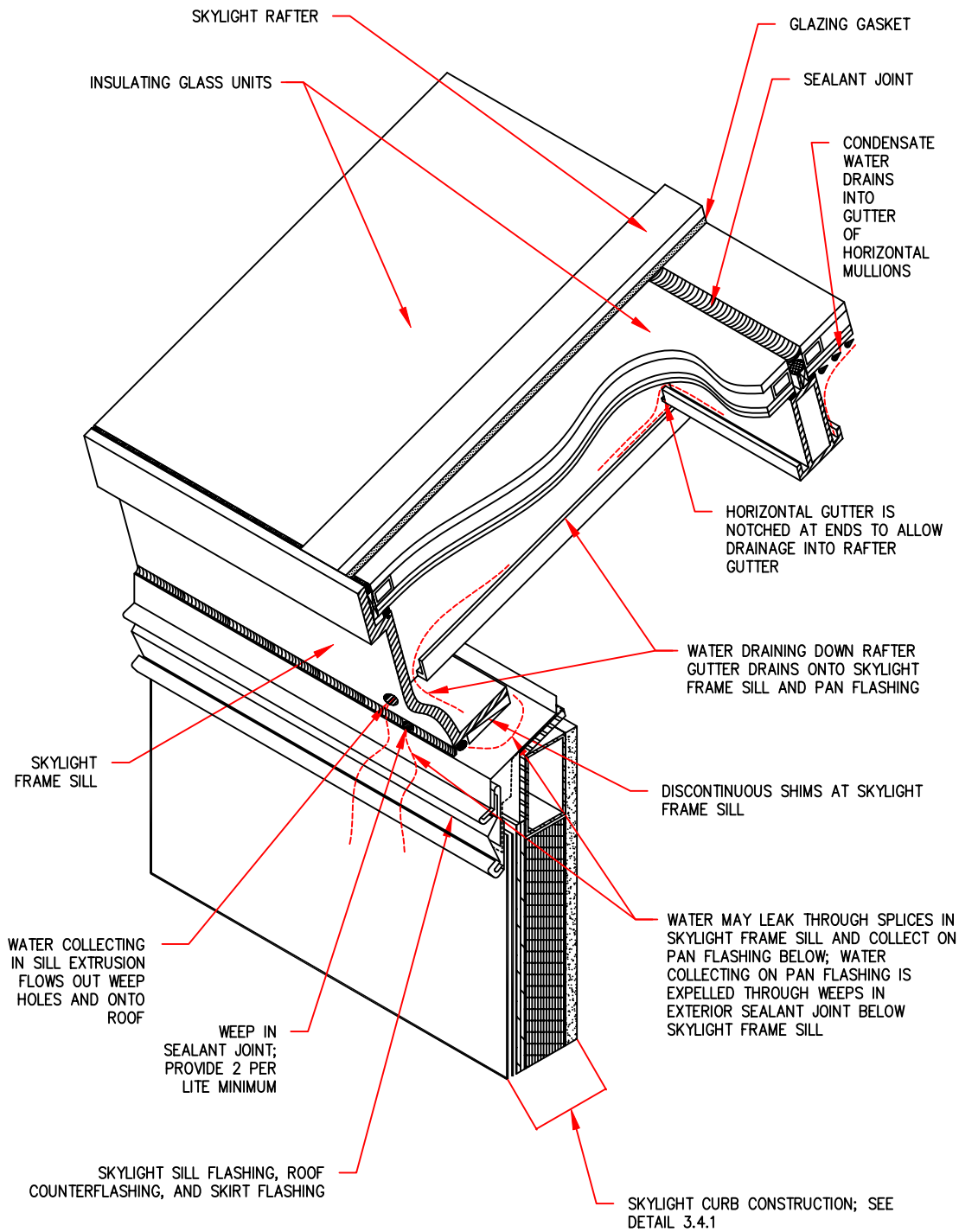

CONCEPTUAL – NOT FOR CONSTRUCTION

3.4-7

**SLOPED GLAZING-
ISOMETRIC OF
CONDENSATE FLOW
PATH AT GUTTER
RAFTER DETAIL**

The details, graphics and related information shown above are intended to illustrate basic design concepts and principles only and should be considered collectively with the appropriate narrative sections of the Whole Building Design Guide (WBDG). The information contained herein is not intended for actual construction, and is subject to revision based on changes and/or refinements in local, state and national building codes, emerging building envelope technologies, and advancements in the research and understanding of building envelope failure and failure mechanisms. The actual design and configuration of these and similar details will vary based upon applicable local, state and national building code requirements, climatic considerations, and economic constraints unique to each project. Full compliance with the manufacturer's recommendations and recognized industry standards for each building envelope material, component and system specified for this and similar fenestration assemblies is recommended, and should be reflected in the appropriate sections of the project specifications.