

**VA**



## U. S. Department of Veterans Affairs

Office of Information and Technology  
*Infrastructure Operations (IO)*

# OIT DESIGN GUIDE TEMPLATES FOR CRITICAL INFRASTRUCTURE IN TELECOMMUNICATIONS SPACES (CLINICAL AND NON-CLINICAL ENVIRONMENTS)

**DEVELOPED BY:  
DATA CENTER AND INFRASTRUCTURE ENGINEERING**

DEPARTMENT OF VETERANS  
AFFAIRS



OFFICE OF INFORMATION AND  
TECHNOLOGY

INFRASTRUCTURE OPERATIONS -  
APPLICATION HOSTING, CLOUD AND  
EDGE SOLUTIONS



ENTERPRISE DATA CENTER AND  
INFRASTRUCTURE ENGINEERING

**EDICT**

ENTERPRISE DATA CENTER  
INFRASTRUCTURE COLLABORATION TEAM

PROJECT:

OIT DESIGN GUIDE TEMPLATES

PROJECT No:

N/A

MARK	DATE	DESCRIPTION

ISSUE:

DRAWING No:

FILE: OIT\_DESIGN\_GUIDE\_TEMPLATES-V4 -  
TD.VSDX

DESIGN BY: KEVIN GRZELKA, CTDC

VERIFIED BY: MICHAEL JULIAN, RCDD  
JOHN WERNAU, KELLY BATES

DOC VERSION No: 4.0

ISSUE DATE: June 1, 2023

SHEET TITLE

COVER

SHEET: 1 OF 57

LEGEND

ELECTRICAL

- # DETAIL NUMBER
- # TYP DETAIL NUMBER TYPICAL THROUGHOUT THIS SHEET
- BONDING BUSBAR
- WIRE MESH CABLE TRAY SIZE COMMENSURATE WITH REQUIREMENTS
- ELECTRICAL SERVICE PANEL
- OVERHEAD POWER DROP CORD WITH L21-20 RECEPTACLE
- OVERHEAD POWER DROP CORD WITH L21-30 RECEPTACLE
- POWER JUNCTION BOX FOR 60 A CONNECTION
- POWER BUSWAY TAP WITH SINGLE BREAKER 3 FT DROP CORD WITH L21-20R FOR STANDARD-DENSITY CABINETS
- POWER BUSWAY TAP WITH DUAL BREAKERS AND QTY TWO 3 FT DROP CORDS WITH L21-20R FOR HIGH-DENSITY CABINETS
- TYPICAL UNSWITCHED 110 V, 20 A DUPLEX CONVENIENCE OUTLET
- MOTION SENSOR LIGHT SWITCH
- CEILING MOUNTED MOTION SENSOR (LOCATIONS AS REQUIRED FOR FULL ROOM COVERAGE)
- PIV ENABLED TWO-FACTOR AUTHENTICATION KEYPAD
- FIXED CAMERA, PAN/TILT/ZOOM, PASSIVE INFRARED CAMERA - DUAL TECHNOLOGY
- LED LIGHTING
- POWER BUSWAY WITH METERED HEADEND FOR A-SIDE POWER DISTRIBUTION
- POWER BUSWAY WITH METERED HEADEND FOR B-SIDE POWER DISTRIBUTION
- UPS MODULAR UPS CABINET (POWER MODULES, BATTERIES, POWER PANELS)

TELECOMMUNICATIONS

- # DETAIL NUMBER
- # TYP DETAIL NUMBER TYPICAL THROUGHOUT THIS SHEET
- WIRE MESH CABLE TRAY SIZE COMMENSURATE WITH REQUIREMENTS
- CONDUIT WITH BUSHING FIRESTOP AND INNERDUCT FOR FIBER
- SLEEVE WITH BUSHING FIRESTOP AND INNERDUCT FOR FIBER
- SLEEVE OR CONDUIT WITH BUSHING FIRESTOP AND INNERDUCT FOR FIBER
- TELECOMMUNICATIONS CHANNEL RACK, 19 IN. RAILS, #12-24 TAPPED EIA HOLE PATTERN, 30 IN. DEEP CHANNEL MINIMUM, 7 FT HIGH, 45 RU, WHITE
- VERTICAL CABLE MANAGER WITH DOOR, 6 IN. WIDE MINIMUM (SIZED TO MEET REQUIREMENT)
- SERVER CABINET, 45 RU, 24 IN. X 48 IN. (NOMINAL), SQUARE PUNCHED RAIL, SINGLE PERFORATED FRONT DOOR, SOLID REAR DOOR (VERTICAL EXHAUST DUCT [VED] IMPLEMENTATION), DOUBLE PERFORATED REAR DOOR (NO VED), TWO-POINT KEYED LOCKS, WHITE, SOLID SIDE PANELS
- TELECOMMUNICATIONS CABINET, 84 IN. HIGH, 44 RU, 24 IN. X 42 IN. (NOMINAL), SQUARE PUNCHED RAIL, SINGLE PERFORATED FRONT DOOR, SOLID REAR DOOR (VERTICAL EXHAUST DUCT [VED] IMPLEMENTATION), DOUBLE PERFORATED REAR DOOR (NO VED), WHITE, SOLID SIDE PANELS, SHOWN WITH TWO 12 IN. VERTICAL CABLE MANAGEMENT SIDECARS (6 IN. VERSIONS AVAILABLE)

ELECTRICAL

- 1 MINIMUM QTY TWO 120 V 20 A CONVENIENCE POWER OUTLETS PER WALL; PLACEMENT DETERMINED BY OTHERS
  - 2 PRIMARY BONDING BUSBAR; PLACEMENT DETERMINED BY OTHERS
  - 3 SECONDARY BONDING BUSBAR; PLACEMENT DETERMINED BY OTHERS
  - 4 SERVICE PANEL FOR A-SIDE POWER, GENERATOR BACKED IF THE FACILITY HAS GENERATION CAPABILITIES. SHALL BE EQUIPPED WITH POWER METER; PLACEMENT PER OTHERS
  - 5 SERVICE PANEL FOR B-SIDE POWER, GENERATOR BACKED IF POSSIBLE. SHALL BE EQUIPPED WITH POWER METER; PLACEMENT PER OTHERS
  - 6 20 A 208 V THREE-PHASE TWIST LOCK RECEPTACLE (L21-20R); 8.5 FT AFF {WYE (5-WIRE)}; COORDINATE INSTALLATION LOCATION WITH TELECOMMUNICATIONS CONTRACTOR
  - 7 30 A 208 V THREE-PHASE TWIST LOCK RECEPTACLE (L21-30R); 8.5 FT AFF {WYE (5-WIRE)}; COORDINATE INSTALLATION LOCATION WITH TELECOMMUNICATIONS CONTRACTOR
  - 8 POWER BUSWAY (VOLTAGE AND AMPERAGE TO SUPPORT ADEQUATE SINGLE & DOUBLE BREAKER 208 V, 20 A, L21-20R BUSWAY TAPS PER SERVER ROW) FED FROM A-SIDE SOURCE
  - 9 POWER BUSWAY (VOLTAGE AND AMPERAGE TO SUPPORT ADEQUATE SINGLE & DOUBLE BREAKER 208 V, 20 A, L21-20R BUSWAY TAPS PER SERVER ROW) FED FROM B-SIDE SOURCE
  - 10 POWER BUSWAY (VOLTAGE AND AMPERAGE SUFFICIENT TO SUPPORT ADEQUATE SINGLE BREAKER 208 V, 20 A, L21-20R BUSWAY TAPS PER NETWORK ROW) FED FROM A-SIDE SOURCE
  - 11 POWER BUSWAY (VOLTAGE AND AMPERAGE SUFFICIENT TO SUPPORT ADEQUATE 208 V, 20 A, L21-20R BUSWAY TAPS PER NETWORK ROW) FED FROM B-SIDE SOURCE
  - 12 BLUE CABLE PATCH FOR A-SIDE UPS
  - 13 YELLOW CABLE PATH FOR B-SIDE UPS
- LIGHTING:
1. LED LIGHTING PLACED IN AISLES DIRECTLY IN FRONT OF AND BEHIND CABINET ROWS
  2. LIGHTING OPERATED BY MOTION SENSOR PER CABINET ROW OR SECTION
  3. 500 LUMENS IN THE HORIZONTAL PLANE AND 200 LUMENS IN THE VERTICAL PLANE REQUIRED MEASURED AT 3 FT AFF IN FRONT OF AND BEHIND EQUIPMENT CABINETS

NOTES

TELECOMMUNICATIONS

- 1 SERVICE PROVIDER ENTRANCE POINT
- 2 SERVICE BACKBONE – ENTRANCE ROOM-MAIN COMPUTER ROOM (MCR) WITH DUAL REDUNDANT PATHWAYS
- 3 MAIN CROSS CONNECT (CAMPUS/BUILDING DISTRIBUTOR) – BACKBONE CABLING (MCR-TELECOMMUNICATIONS ROOMS)
- 4 ENTRANCE ROOM INTERCONNECT
- 5 HORIZONTAL DISTRIBUTION TO WORK AREA OUTLETS (WAO)
- 6 ADDITIONAL CABINETS OR TELECOMMUNICATIONS RACKS TO MEET REQUIREMENTS
- 7 HORIZONTAL DISTRIBUTION AREA (HDA) – SIDE A
- 8 HORIZONTAL DISTRIBUTION AREA – SIDE B
- 9 MAIN DISTRIBUTION AREA (MDA) – SIDE A
- 10 MAIN DISTRIBUTION AREA – SIDE B
- 11 STANDARD DENSITY (SD) CABINET SUPPORTING 5 KW REDUNDANT
- 12 HIGH DENSITY (HD) CABINET SUPPORTING 10 KW REDUNDANT
- 13 NETWORK CABINET WITH VERTICAL CABLE MANAGEMENT SIDECARS, SUPPORTING 5 KW REDUNDANT
- 14 WIRE MESH CABLE TRAY MINIMUM OF 4 IN. X 12 IN. WITH SECOND LEVEL OF FIBER CHANNEL PATHWAY (4 IN. X 4 IN.)
- 15 BLUE CABLE TRAY PATH FOR CABLES TO THE A-SIDE MDA/HDA
- 16 YELLOW CABLE TRAY PATH FOR CABLES TO THE B-SIDE MDA/HDA
- 17 NETWORK CHANNEL RACK

ARCHITECTURAL

- 4 FT BY 8 FT AC GRADE 3/4 IN. TRADE SIZE PLYWOOD BACKBOARD PAINTED HIGH-GLOSS WHITE WITH TWO COATS OF FIRE RESISTANT PAINT FOR SERVICE PROVIDER / SECURITY / VIDEO / ET CETERA
- 3 FT WIDE, 8 FT HIGH DOOR, FIRE RESISTANT TO 3/4 HOUR OR MORE PER AUTHORITY HAVING JURISDICTION (AHJ); DOOR SWING REPRESENTATIVE ONLY
- 6 FT WIDE, 8 FT HIGH DOOR, NO CENTER MULLION OR REMOVABLE MULLION, FIRE RESISTANT TO 3/4 HOUR OR MORE PER AHJ; DOOR SWING REPRESENTATIVE ONLY
- 30 IN. WIDE BY 36 IN. FRONT CLEARANCE REQUIRED AROUND ELECTRICAL PANEL BOARDS
- 36 IN. CLEARANCE REQUIRED AROUND FRONT, BACK, AND SIDES OF RACKS AND CABINETS

MECHANICAL

- STANDARD 25% OPEN PERFORATED FLOOR TILE
- GRATE FLOOR TILE
- COLD AISLE CONTAINMENT PVC CURTAIN
- COLD AISLE CONTAINMENT AREA
- COMPUTER ROOM AIR CONDITIONER (CRAC) (SEE COMPUTATIONAL FLUID DYNAMICS REQUIRED FOR SIZING)
- REQUIRED CLEARANCE AROUND CRACs (SIZE VARIES DEPENDING UPON CRAC MANUFACTURER)
- SPLIT PACKAGE AIR CONDITIONER OR EQUIVALENT 24/7 SUPPLY AIR TO REJECT 17,000 BTU/H (5 KW) PER TELECOMMUNICATIONS RACK
- AIR CONDITIONER THERMOSTAT

ARCHITECTURAL

- FLOOR TO CEILING HEIGHT:
1. TELECOMMUNICATION ROOMS INCLUDING NETWORK SUPPORT CENTERS: MAXIMUM EXTENT POSSIBLE
  2. DATA CENTERS EXCLUDING EXTRA SMALL NETWORK SUPPORT CENTERS: MINIMUM 16 FT SLAB TO DECK ABOVE
- FLOOR COMPOSITION:
1. ELECTROSTATIC DISCHARGE (ESD) COATING FOR RAISED FLOOR SYSTEMS
  2. STATIC DISSIPATIVE COATING OR MATERIAL FOR SLAB FLOORS
  3. CONCRETE SLAB 5 IN. THICKNESS AT GROUND
  4. STEEL DECK AND FILL FOR FLOORS ABOVE GROUND
  5. AVOID ACCESS FLOOR PLENUMS FOR AIR DISTRIBUTION PURPOSES
- WALLS: FULL HEIGHT TO DECK ABOVE FOR ALL TELECOMMUNICATION SPACES
- CEILING: NO SUSPENDED CEILING ALLOWED
- DATA CENTER SIZE ALLOCATION PER CHART BELOW:
- | Data Center Size | Square Footage | Form Factor                        |
|------------------|----------------|------------------------------------|
| Extra Small      | 775 (785)      | 24 ft X 32.5 ft (20 ft X 39.25 ft) |
| Small            | 1152           | 24 ft X 48 ft                      |
| Medium           | 1760           | 40 ft X 44 ft                      |
- CONTACT DATA CENTER AND INFRASTRUCTURE ENGINEERING (VAITESEDATACENTERENGINEERING2@VA.GOV) TO DETERMINE WHAT SIZE DATA CENTER IS REQUIRED FOR YOUR FACILITY
- FLOORPLANS ARE NOT TO SCALE (NTS)  
DOCUMENTS ARE NOT TO BE USED FOR CONSTRUCTION

MECHANICAL

CHANGES TO DESIGN WILL REQUIRE A NEW COMPUTATIONAL FLUID DYNAMICS (CFD) ANALYSIS TO BE PERFORMED



DEPARTMENT OF VETERANS  
AFFAIRS

OFFICE OF INFORMATION AND  
TECHNOLOGY

INFRASTRUCTURE OPERATIONS -  
APPLICATION HOSTING, CLOUD AND  
EDGE SOLUTIONS



ENTERPRISE DATA CENTER AND  
INFRASTRUCTURE ENGINEERING

**EDCT**  
ENTERPRISE DATA CENTER  
INFRASTRUCTURE COLLABORATION TEAM

PROJECT:

OIT DESIGN GUIDE TEMPLATES

PROJECT No: N/A

MARK	DATE	DESCRIPTION

ISSUE:

DRAWING No:  
FILE: OIT\_Design\_Guide\_Templates-V4 - TD.VSDX

DESIGN BY: KEVIN GRZELKA, CTDC

VERIFIED BY: MICHAEL JULIAN, RCDD  
JOHN WERNAU, KELLY BATES

DOC VERSION No: 4.0

ISSUE DATE: June 1, 2023

SHEET TITLE

LEGEND

SHEET: 2 OF 57

1

2

3

4

D

C

B

A

# TELECOMMUNICATIONS SPACES (ARCHITECTURAL)

1

2

3

4

DEPARTMENT OF VETERANS AFFAIRS



OFFICE OF INFORMATION AND TECHNOLOGY

INFRASTRUCTURE OPERATIONS - APPLICATION HOSTING, CLOUD AND EDGE SOLUTIONS



ENTERPRISE DATA CENTER AND INFRASTRUCTURE ENGINEERING

EDICT

ENTERPRISE DATA CENTER INFRASTRUCTURE COLLABORATION TEAM

PROJECT:

OIT DESIGN GUIDE TEMPLATES

PROJECT No:

N/A

MARK DATE DESCRIPTION

ISSUE:

DRAWING No:

FILE: OIT\_DESIGN\_GUIDE\_TEMPLATES-V4 - TD.VSDX

DESIGN BY: KEVIN GRZELKA, CTDC

VERIFIED BY: MICHAEL JULIAN, RCDD  
JOHN WERNAU, KELLY BATES

DOC VERSION No: 4.0

ISSUE DATE: June 1, 2023

SHEET TITLE

TELECOMMUNICATIONS SPACES (ARCHITECTURAL)

SHEET: 3 OF 57

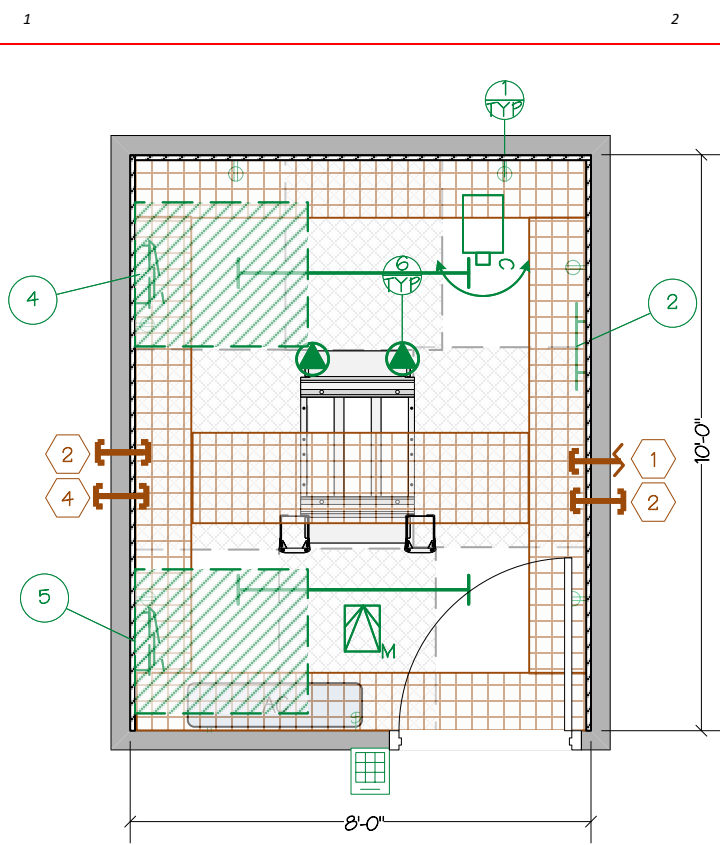

3 GENERIC FLOOR PLAN FOR ENTRANCE ROOM (ONE SERVICE PROVIDER)  
NOT FOR HEALTHCARE ENVIRONMENTS

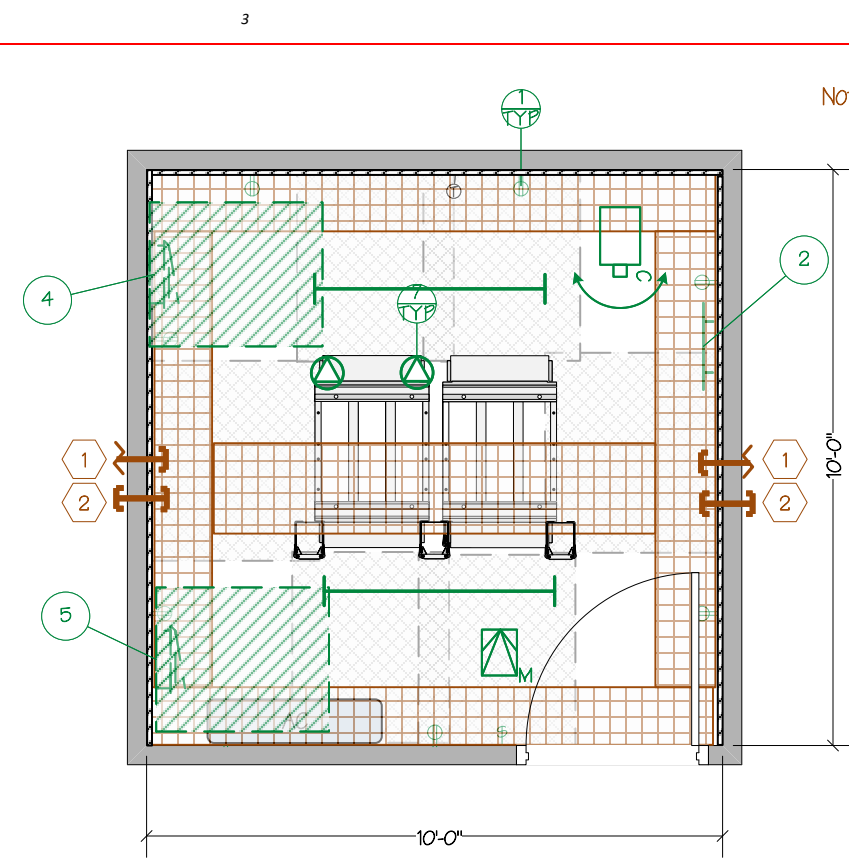

4 GENERIC FLOOR PLAN FOR ENTRANCE ROOM (TWO SERVICE PROVIDERS)  
NOT FOR HEALTHCARE ENVIRONMENTS

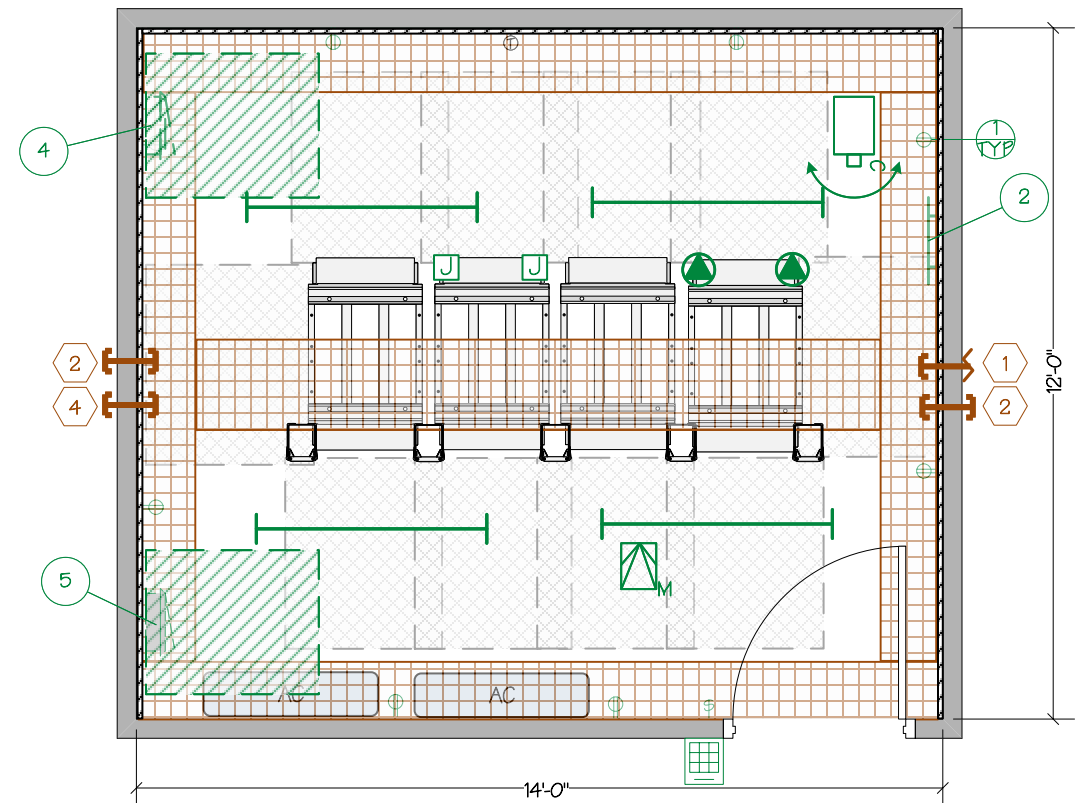

2 GENERIC FLOOR PLAN FOR HEALTHCARE ENTRANCE ROOM  
TWO REQUIRED PER CAMPUS (CAN ALSO ACT AS A TR FOR A SERVING ZONE)

NOTE:

THREE FT CLEARANCE FROM WALL MOUNTED EQUIPMENT MUST BE MAINTAINED.

30 IN. WIDE BY 36 IN.  
FRONT CLEARANCE REQUIRED  
AROUND ELECTRICAL PANEL  
BOARDS

36 IN. CLEARANCE  
REQUIRED AROUND FRONT,  
BACK, AND SIDES OF RACKS  
AND CABINETS

TWO L21-20 BRANCH CIRCUITS PER RACK CAN BE USED FOR ALL RACKS ELIMINATING THE NEED FOR ZONE PDUS IF BREAKER SPACE IS NO AN ISSUE (ALTERNATIVELY, ZPDUS CAN SUPPORT EITHER TWO OR THREE RACKS EACH)

1 TELECOMMUNICATION ENTRANCE ROOM NOTES



PROJECT:

OIT DESIGN GUIDE TEMPLATES

PROJECT No:

N/A

MARK	DATE	DESCRIPTION

ISSUE:

DRAWING No:

FILE: OIT\_Design\_Guide\_Templates-V4 - TD.VSDX

DESIGN BY: KEVIN GRZELKA, CTDC

VERIFIED BY: MICHAEL JULIAN, RCDD  
JOHN WERNAU, KELLY BATES

DOC VERSION No: 4.0

ISSUE DATE: June 1, 2023

SHEET TITLE

TELECOMMUNICATION ENTRANCE ROOMS

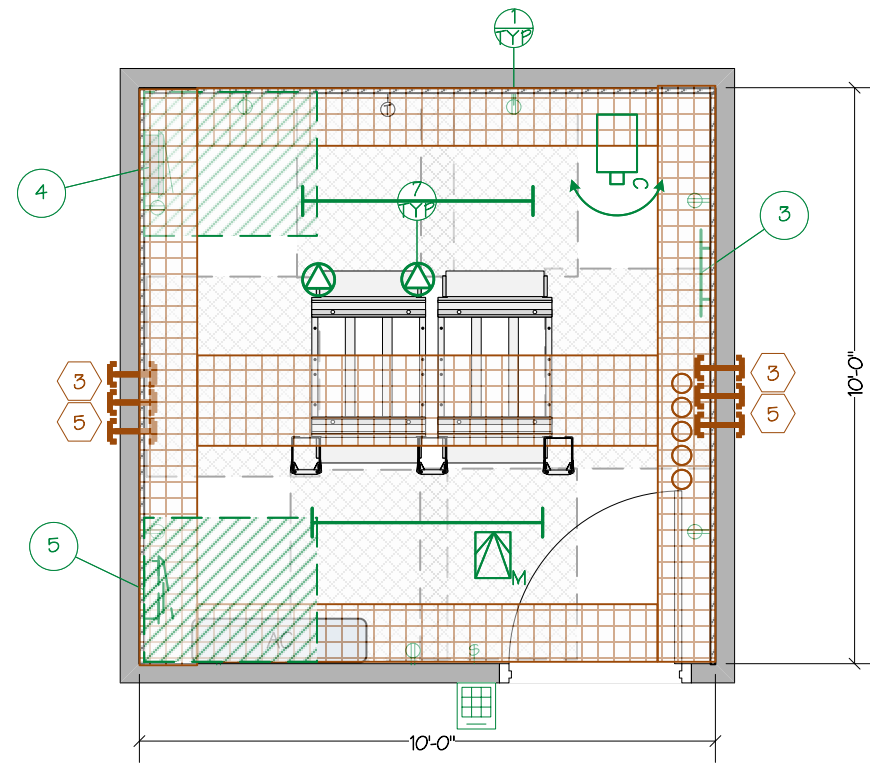

3 GENERIC FLOOR PLAN FOR TELECOMMUNICATIONS ROOMS (TWO RACK REQUIREMENT)  
 (TELECOMMUNICATIONS SPACE SUPPORTING NETWORK DISTRIBUTION TO WORK AREA OUTLETS)  
 MINIMUM REQUIREMENT FOR HEALTHCARE FACILITY REMODELS

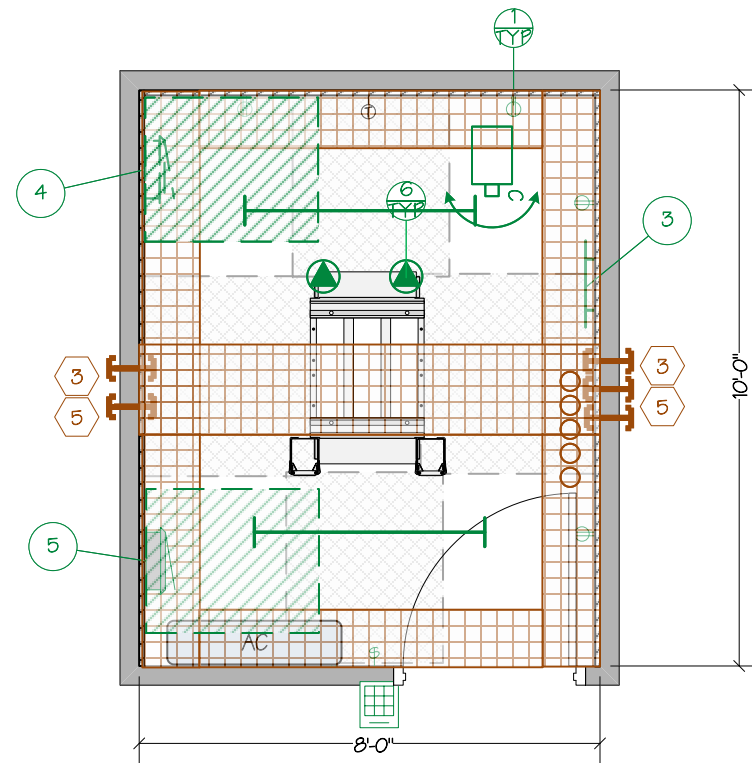

4 GENERIC FLOOR PLAN FOR TELECOMMUNICATIONS ROOMS (ONE RACK REQUIREMENT)  
 (TELECOMMUNICATIONS SPACE SUPPORTING NETWORK DISTRIBUTION TO WORK AREA OUTLETS)

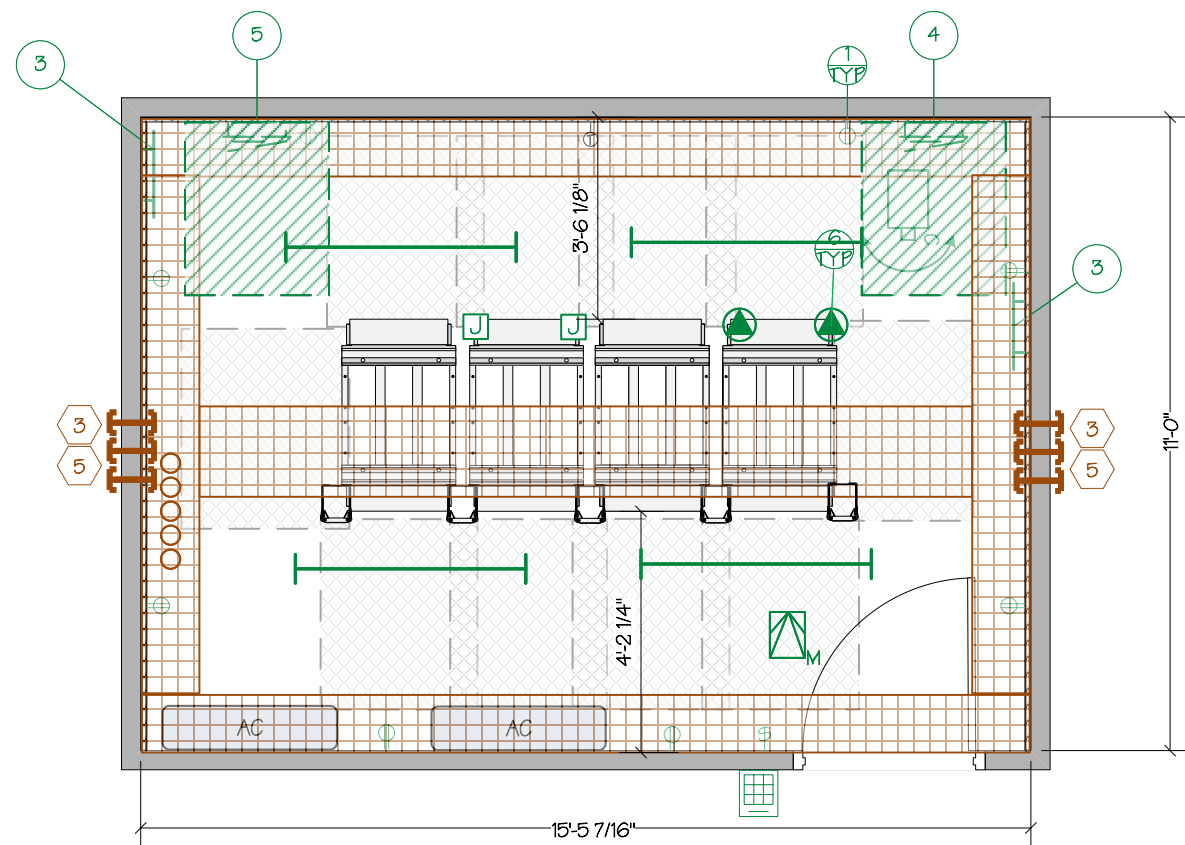

2 GENERIC FLOOR PLAN FOR HEALTH CARE FACILITY TELECOMMUNICATIONS ROOMS

NOTE:

- THERE SHALL BE A MINIMUM OF ONE TELECOMMUNICATIONS ROOM (TR) PER FLOOR.
- ADDITIONAL ROOMS SHOULD BE PROVIDED WHEN THE HORIZONTAL DISTRIBUTION DISTANCE TO THE WORK AREA EXCEEDS 90 M (295 FT) OR THE ROOM SIZE CAN'T SUPPORT ALL WORK AREA OUTLETS.

FLOOR SPACE REQUIREMENT:

1. MINIMUM OF 80 FT<sup>2</sup> FOR A ONE RACK TR
2. ADD AN ADDITIONAL 20 FT<sup>2</sup> PER ADDITIONAL RACK
3. MINIMUM OF 170 FT<sup>2</sup> FOR A HEALTH CARE FACILITY TR
4. TWO L21-20 BRANCH CIRCUITS PER RACK CAN BE USED FOR ALL RACKS ELIMINATING THE NEED FOR ZPDUS IF BREAKER SPACE IS NOT AN ISSUE (ALTERNATIVELY, ZPDUS CAN SUPPORT EITHER TWO OR THREE RACKS EACH)
5. 3 FT OF CLEARANCE ON THREE SIDES OF THE RACKS MUST BE MAINTAINED
6. THE FOURTH SIDE AT THE END OF A ROW MUST BE AT LEAST 12 IN FROM THE WALL
7. 3 FT OF CLEARANCE MUST BE MAINTAINED FROM ANY WALL-MOUNTED EQUIPMENT TO THE RACKS AS WELL
8. 30 IN. WIDE BY 36 IN. FRONT CLEARANCE REQUIRED AROUND ELECTRICAL PANEL BOARDS

A MINIMUM OF FIVE METRIC DESIGNATOR 103 (TRADE SIZE 4) CONDUITS OR SLEEVES SHOULD BE PROVIDED TO SERVICE UP TO 40,000 FT<sup>2</sup> OF USABLE FLOOR SPACE. ONE ADDITIONAL CONDUIT OR SLEEVE SHOULD BE PROVIDED FOR EACH ADDITIONAL 40,000 FT<sup>2</sup> OF USABLE FLOOR SPACE

EACH RACK MUST BE CAPABLE OF SUPPORTING 5 KW OF LOAD. HOWEVER, IN AGGREGATE FOR TRS WITH MORE THAN ONE RACK, THE FULL 5 KW OF HEAT REJECTION PER RACK IS NOT REQUIRED. SEE BELOW:

- 1 RACK TR = 5 KW COOLING
- 2 RACK TR = 7 KW COOLING
- 3 RACK TR = 8.5 KW COOLING
- 4 RACK TR = 10 KW COOLING

1 TELECOMMUNICATION ROOM NOTES



PROJECT:

OIT DESIGN GUIDE TEMPLATES

PROJECT No:

N/A

MARK	DATE	DESCRIPTION

ISSUE:

DRAWING No:

FILE: OIT\_Design\_Guide\_Templates-V4 - TD.VSDX

DESIGN BY: KEVIN GRZELKA, CTDC

VERIFIED BY: MICHAEL JULIAN, RCDD  
JOHN WERNAU, KELLY BATES

DOC VERSION No: 4.0

ISSUE DATE: June 1, 2023

SHEET TITLE

TELECOMMUNICATIONS ROOMS

A HORIZONTAL CABLE DISTANCE STUDY IS ONE APPROACH TO DEFINE TELECOMMUNICATIONS ROOM (TR) LOCATIONS. THE STUDY LOCATES THE TR IN THE PROPOSED LOCATION AND DRAWS FOUR STRAIGHT 262 FOOT (80 M) LINES ORIGINATING AT THE CENTER OF THE ROOM, TO THE NORTH, SOUTH, EAST AND WEST, AND THEN CONNECTS THE ENDS OF THE FOUR LINES TOGETHER, CREATING A "DIAMOND," WITH THE PROPOSED TR LOCATION AT THE CENTER. THE PROPOSED TR LOCATION AND RESULTING DIAMOND COVERAGE AREA IS THEN MOVED AROUND THE FLOOR PLATE UNTIL ALL AREAS OF A GIVEN FLOOR ARE WITHIN A DIAMOND. THIS ENSURES THAT ALL AREAS ARE WITHIN THE MAXIMUM ALLOTTED CABLE DISTANCE. ALTERNATELY, AN ACTUAL DISTANCE STUDY CAN BE USED TO ENSURE THAT PERMANENT LINK DISTANCES ARE 90M OR LESS INCLUDING CABLE RUNS IN THE HORIZONTAL AND VERTICAL PLANES.

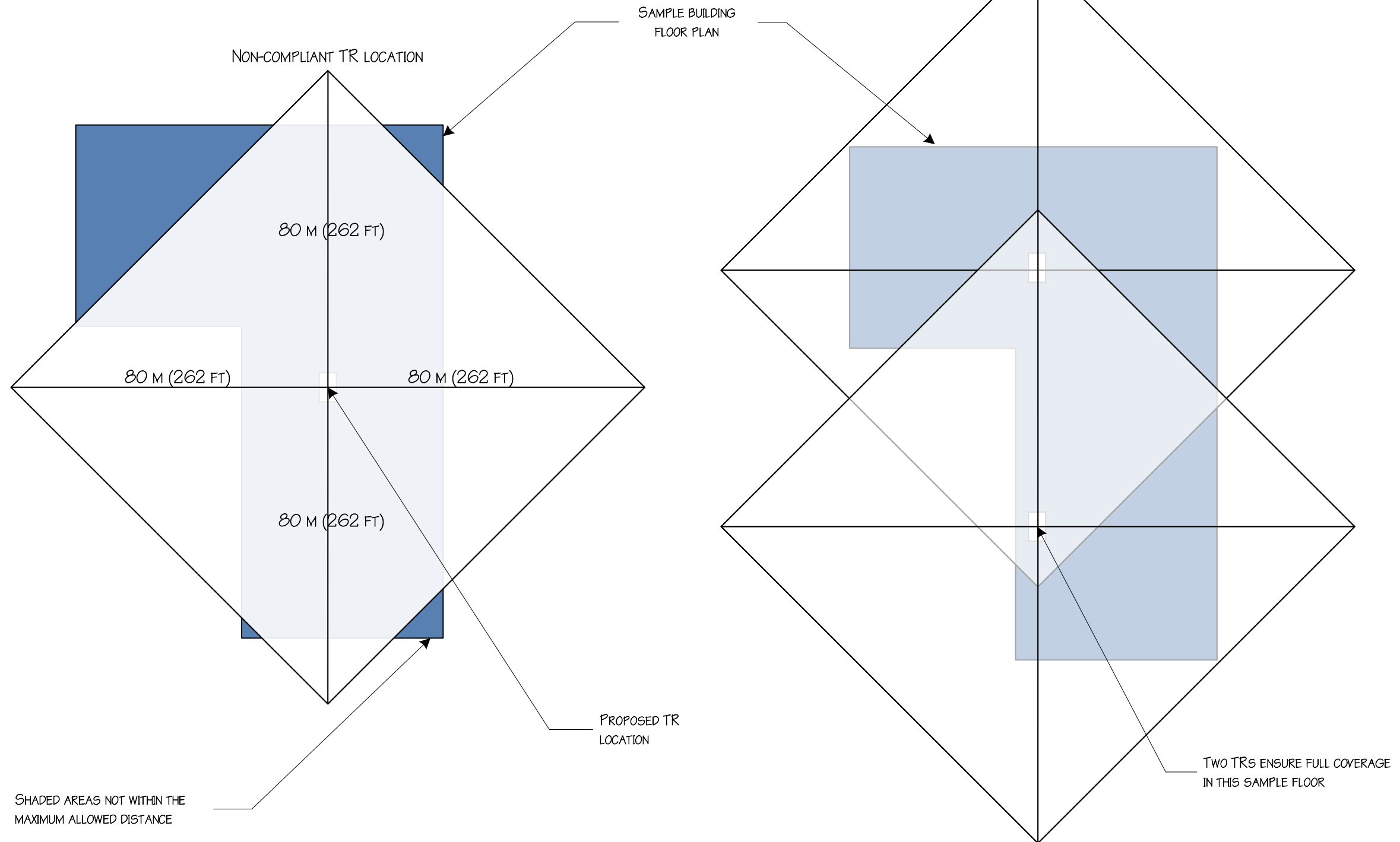

① HORIZONTAL CABLE DISTANCE STUDY (DIAMOND ANALYSIS) FOR TELECOMMUNICATION ROOM LOCATION PLANNING  
NTS



**PROJECT:**

OIT DESIGN GUIDE TEMPLATES

PROJECT No: N/A

MARK	DATE	DESCRIPTION

ISSUE:

DRAWING No:

FILE: OIT\_DESIGN\_GUIDE\_TEMPLATES-V4 - TD.VSDX

DESIGN BY: KEVIN GRZELKA, CTDC

VERIFIED BY: MICHAEL JULIAN, RCDD  
JOHN WERNAU, KELLY BATES

DOC VERSION No: 4.0

ISSUE DATE: June 1, 2023

SHEET TITLE

HORIZONTAL CABLE DISTANCE STUDY (DIAMOND ANALYSIS)

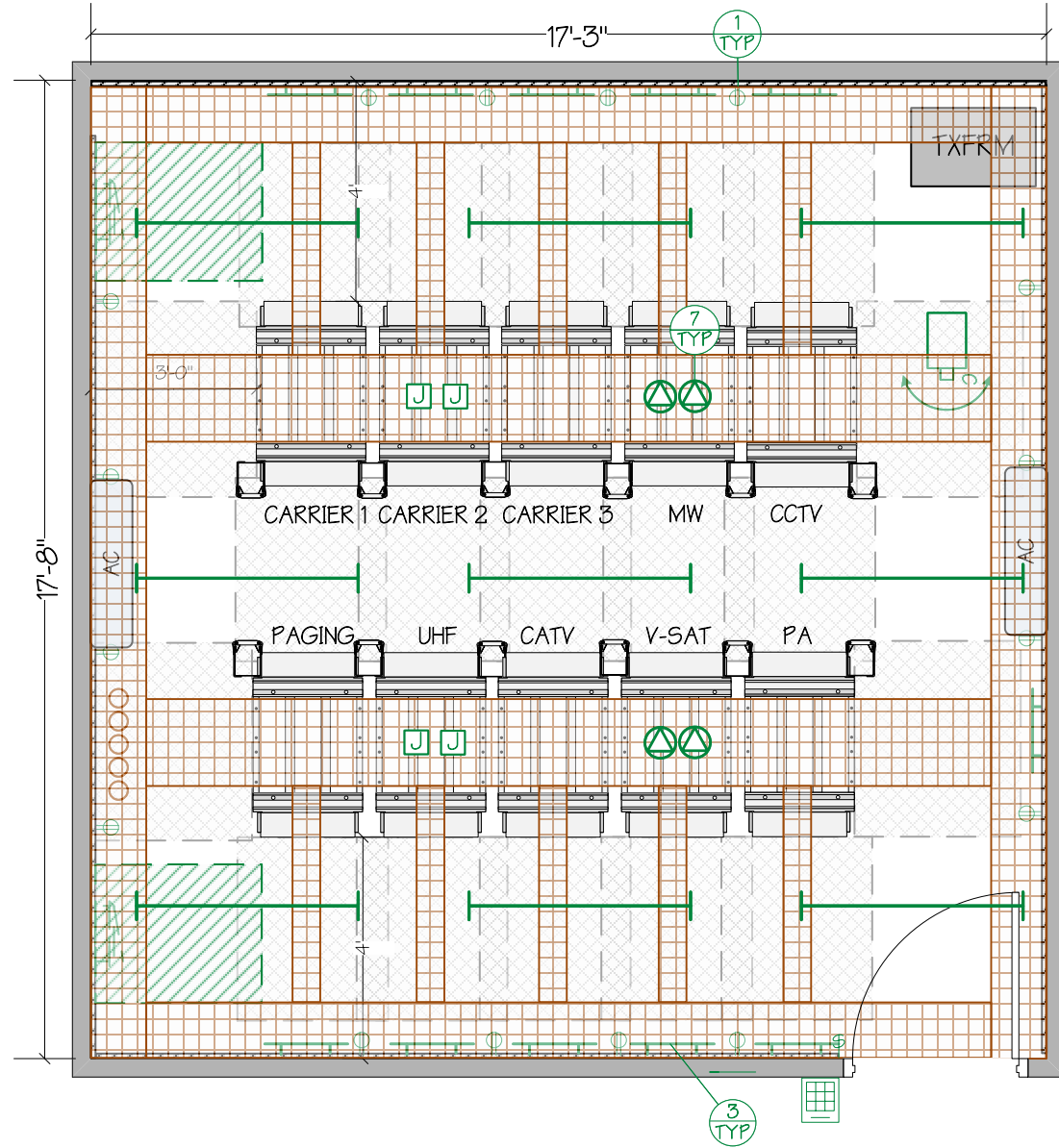

1 ANTENNA ENTRANCE ROOM

**NOTE:**

THE ANTENNA ENTRANCE ROOM (AKA ANTENNA HEADEND EQUIPMENT ROOM) SHALL BE LOCATED IN THE MECHANICAL PENTHOUSE OR OTHER AREA DICTATED BY SYSTEM DESIGN AND AS CLOSE TO THE ANTENNA FARM AS POSSIBLE. THE ROOM SHALL ACCOMMODATE ALL PROVIDED AND PLANNED FMS RADIO FREQUENCY BASED (RF) SPECIAL SYSTEMS AND HEADEND EQUIPMENT CABINETS (I.E., DAS, MATV, M/W, HF, V-SAT, TVRO, SSV, RED, PA, TWO-WAY RADIO, RPS, ETC.)

THE ROOM SHALL BE DESIGNED TO SUPPORT RF HEADEND EQUIPMENT FOR A MINIMUM OF SIX SEPARATE SYSTEMS, FOUR FUTURE SYSTEMS, OVERHEAD AND WALL WIRE MANAGEMENT SYSTEMS, WEATHERPROOF WALL/CEILING CABLE FEEDTHROUGHS, AND CONDUITS

SYSTEM LAYOUT IS NOTIONAL AND DEPENDS UPON SITE REQUIREMENTS

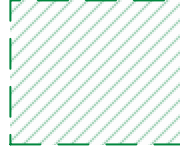
 30 IN. WIDE BY 36 IN. FRONT CLEARANCE REQUIRED AROUND 120/208 V ELECTRICAL PANEL BOARDS

FOUR FOOT CLEARANCE REQUIRED BEHIND RACKS TO ALLOW FOR 12 IN. OF WALL-MOUNTED EQUIPMENT

TWO L21-20 BRANCH CIRCUITS PER RACK CAN BE USED FOR ALL RACKS ELIMINATING THE NEED FOR ZONE PDUS IF BREAKER SPACE IS NOT AN ISSUE (ALTERNATELY, ZPDUS CAN SUPPORT EITHER TWO OR THREE RACKS EACH)



**PROJECT:**

OIT DESIGN GUIDE TEMPLATES

PROJECT No:

N/A

MARK	DATE	DESCRIPTION

**ISSUE:**

<b>DRAWING No:</b>	
<b>FILE:</b>	OIT_Design_Guide_Templates-V4 - TD.VSDX
<b>DESIGN BY:</b>	KEVIN GRZELKA, CTDC
<b>VERIFIED BY:</b>	MICHAEL JULIAN, RCDD JOHN WERNAU, KELLY BATES
<b>DOC VERSION No:</b>	4.0
<b>ISSUE DATE:</b>	June 1, 2023

**SHEET TITLE**

ANTENNA ENTRANCE ROOM



**PROJECT:**

OIT DESIGN GUIDE TEMPLATES

PROJECT No:

N/A

MARK	DATE	DESCRIPTION

**ISSUE:**

**DRAWING No:**

FILE: OIT\_Design\_Guide\_Templates-V4 - TD.VSDX

DESIGN BY: KEVIN GRZELKA, CTDC

VERIFIED BY: MICHAEL JULIAN, RCDD  
JOHN WERNAU, KELLY BATES

DOC VERSION No: 4.0

ISSUE DATE: June 1, 2023

**SHEET TITLE**

NETWORK SUPPORT CENTER

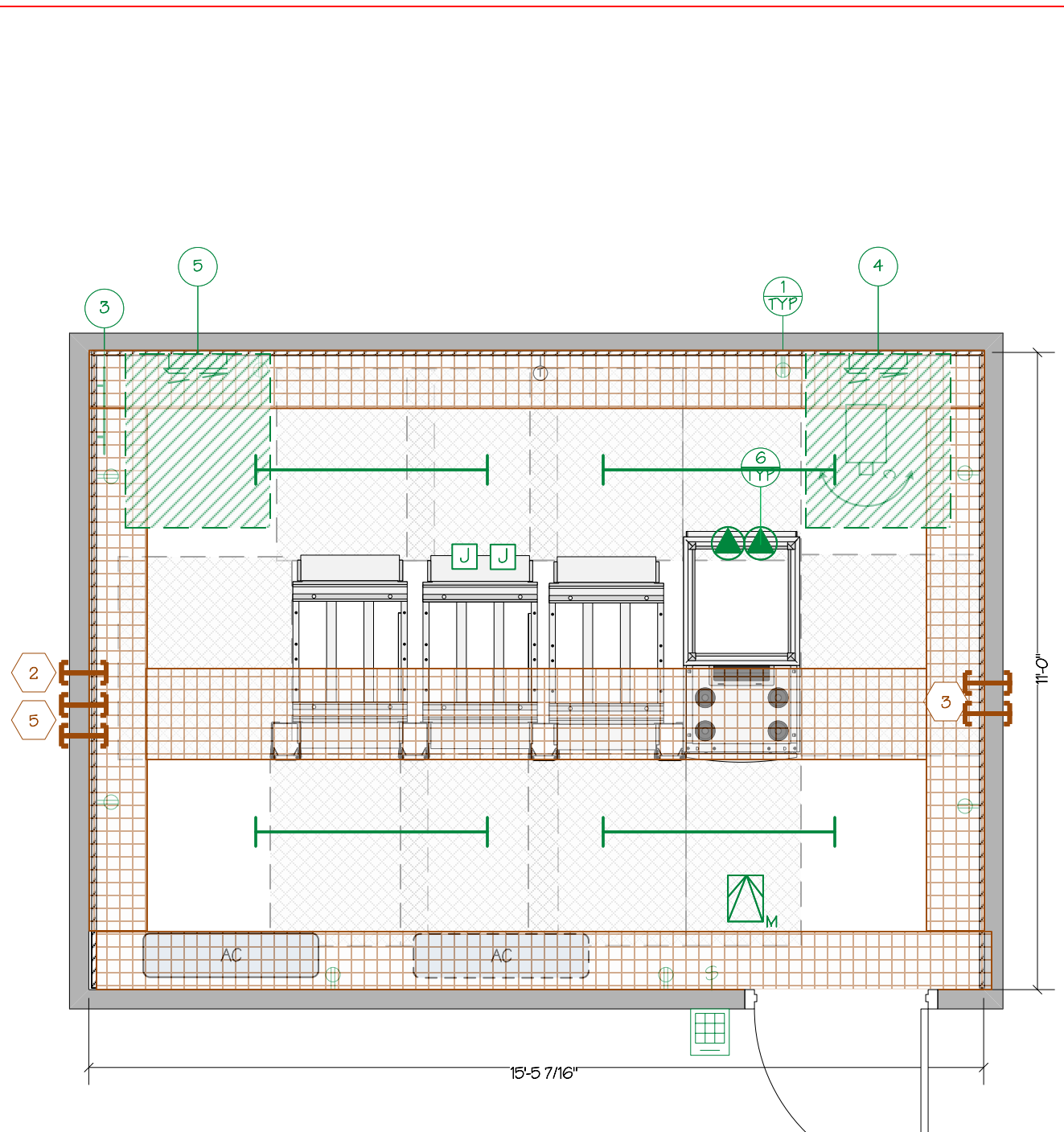
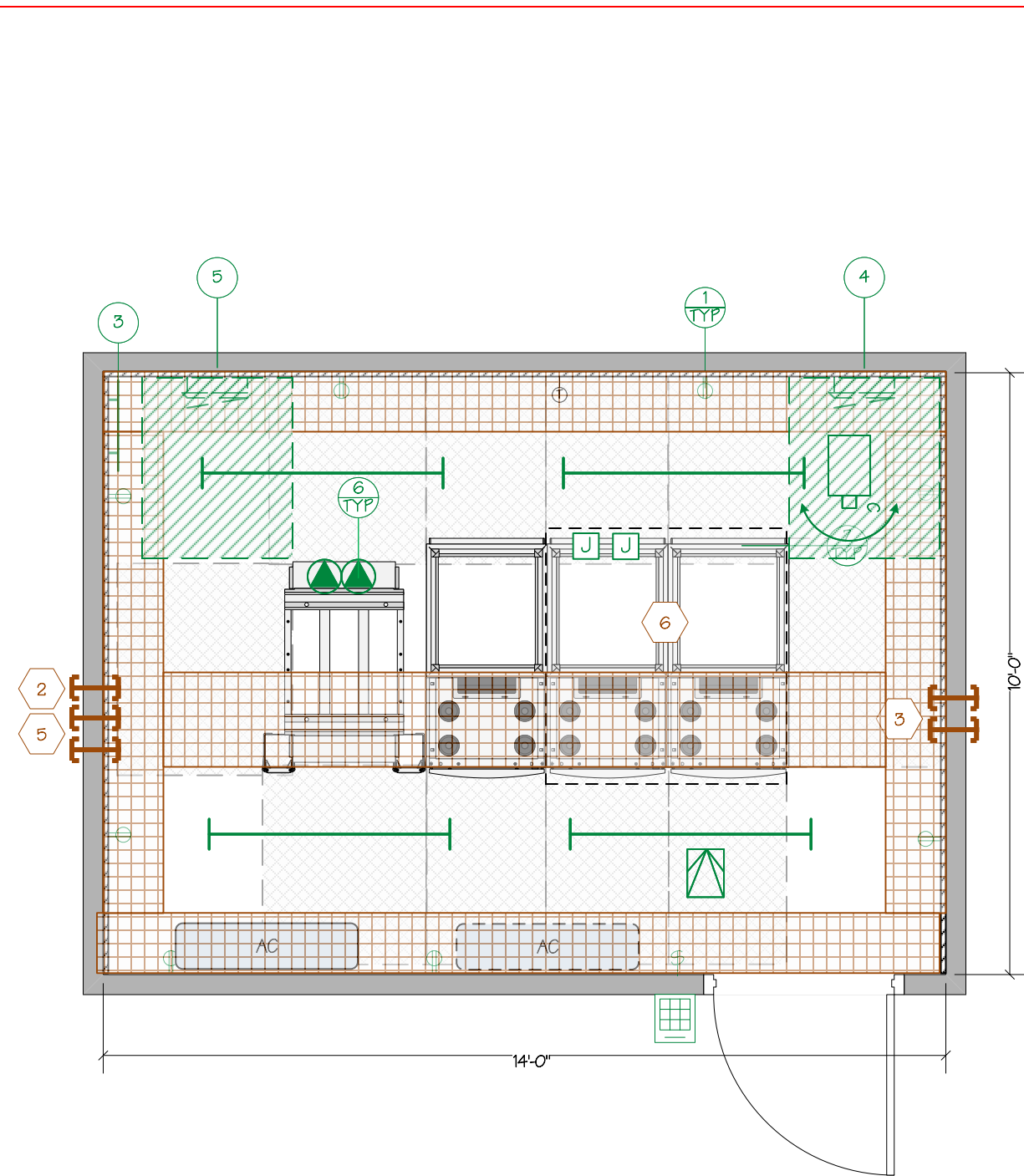

2 GENERIC FLOOR PLAN FOR NETWORK SUPPORT CENTERS  
COMPOSITION OF SERVER CABINETS AND NETWORK RACKS DEPENDENT UPON SITE REQUIREMENT

1 GENERIC FLOOR PLAN FOR HEALTH CARE FACILITY EQUIPMENT ROOM (NETWORK SUPPORT CENTER)  
COMPOSITION OF SERVER CABINETS AND NETWORK RACKS DEPENDENT UPON SITE REQUIREMENT



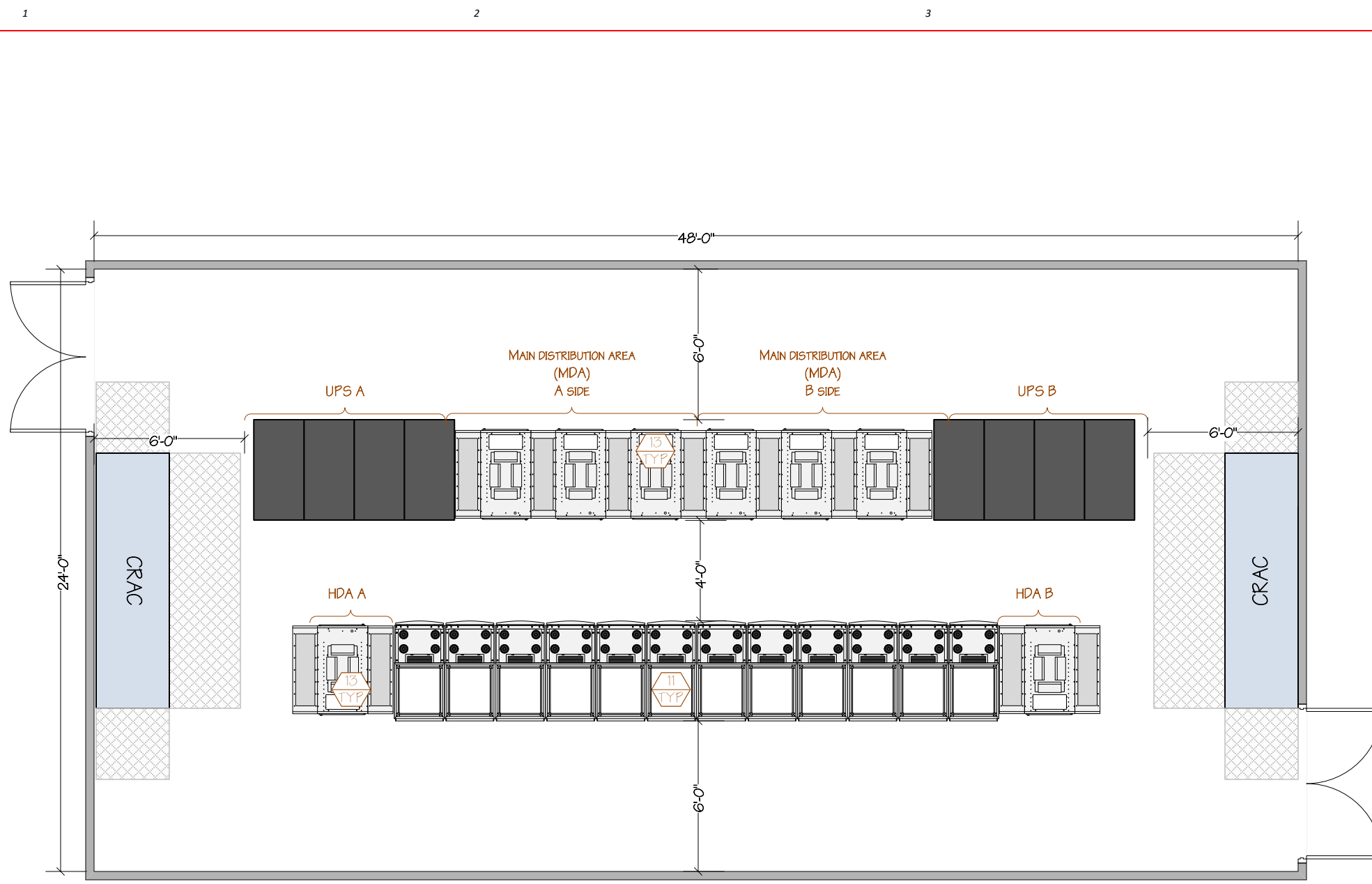

NOTE: SEE THE GENERIC SMALL CAMPUS SUPPORT CENTER (DATA CENTER) DESIGN PORTFOLIO PACKAGE FOR DETAILED IMPLEMENTATION INSTRUCTIONS

1 GENERIC FLOOR PLAN FOR SMALL DATA CENTERS (1,152 FT<sup>2</sup>)

DEPARTMENT OF VETERANS AFFAIRS



OFFICE OF INFORMATION AND TECHNOLOGY

INFRASTRUCTURE OPERATIONS - APPLICATION HOSTING, CLOUD AND EDGE SOLUTIONS



ENTERPRISE DATA CENTER AND INFRASTRUCTURE ENGINEERING

EDCT

ENTERPRISE DATA CENTER INFRASTRUCTURE COLLABORATION TEAM

PROJECT:

OIT DESIGN GUIDE TEMPLATES

PROJECT No:

N/A

MARK	DATE	DESCRIPTION

ISSUE:

DRAWING No:

FILE: OIT\_DESIGN\_GUIDE\_TEMPLATES-V4 - TD.VSDX

DESIGN BY: KEVIN GRZELKA, CTDC

VERIFIED BY: MICHAEL JULIAN, RCDD  
JOHN WERNAU, KELLY BATES

DOC VERSION No: 4.0

ISSUE DATE: June 1, 2023

SHEET TITLE

SMALL DATA CENTER

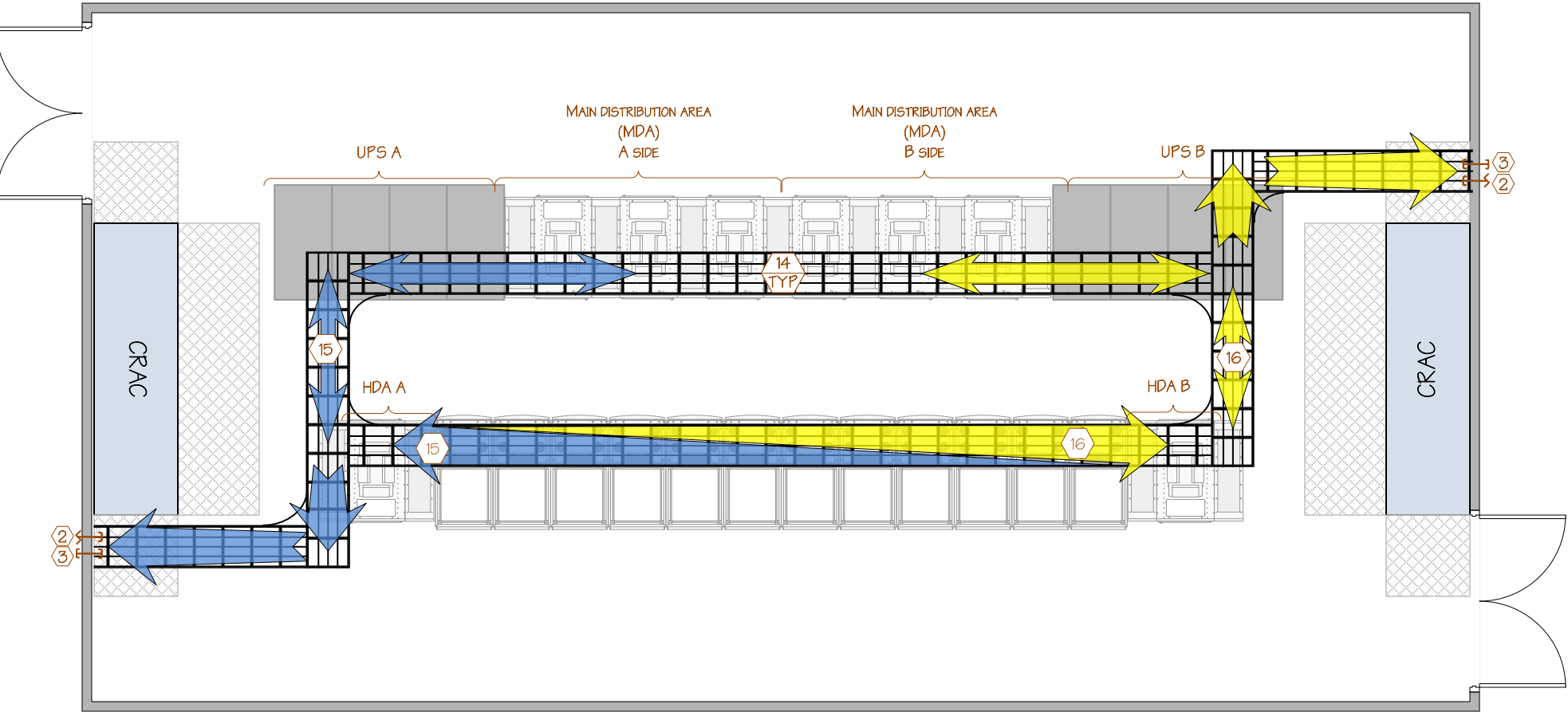

NOTE: SEE THE GENERIC SMALL CAMPUS SUPPORT CENTER (DATA CENTER) DESIGN PORTFOLIO PACKAGE FOR DETAILED IMPLEMENTATION INSTRUCTIONS

1 SMALL DATA CENTER - DATA CABLE TRAY LAYOUT



PROJECT:

OIT DESIGN GUIDE TEMPLATES

PROJECT No:

N/A

MARK	DATE	DESCRIPTION

ISSUE:

DRAWING No:  
 FILE: OIT\_Design\_Guide\_Templates-V4 - TD.VSDX  
 DESIGN BY: KEVIN GRZELKA, CTDC  
 VERIFIED BY: MICHAEL JULIAN, RCDD  
 JOHN WERNAU, KELLY BATES  
 DOC VERSION No: 4.0  
 ISSUE DATE: June 1, 2023

SHEET TITLE

SMALL DATA CENTER - PATHWAY DETAILS

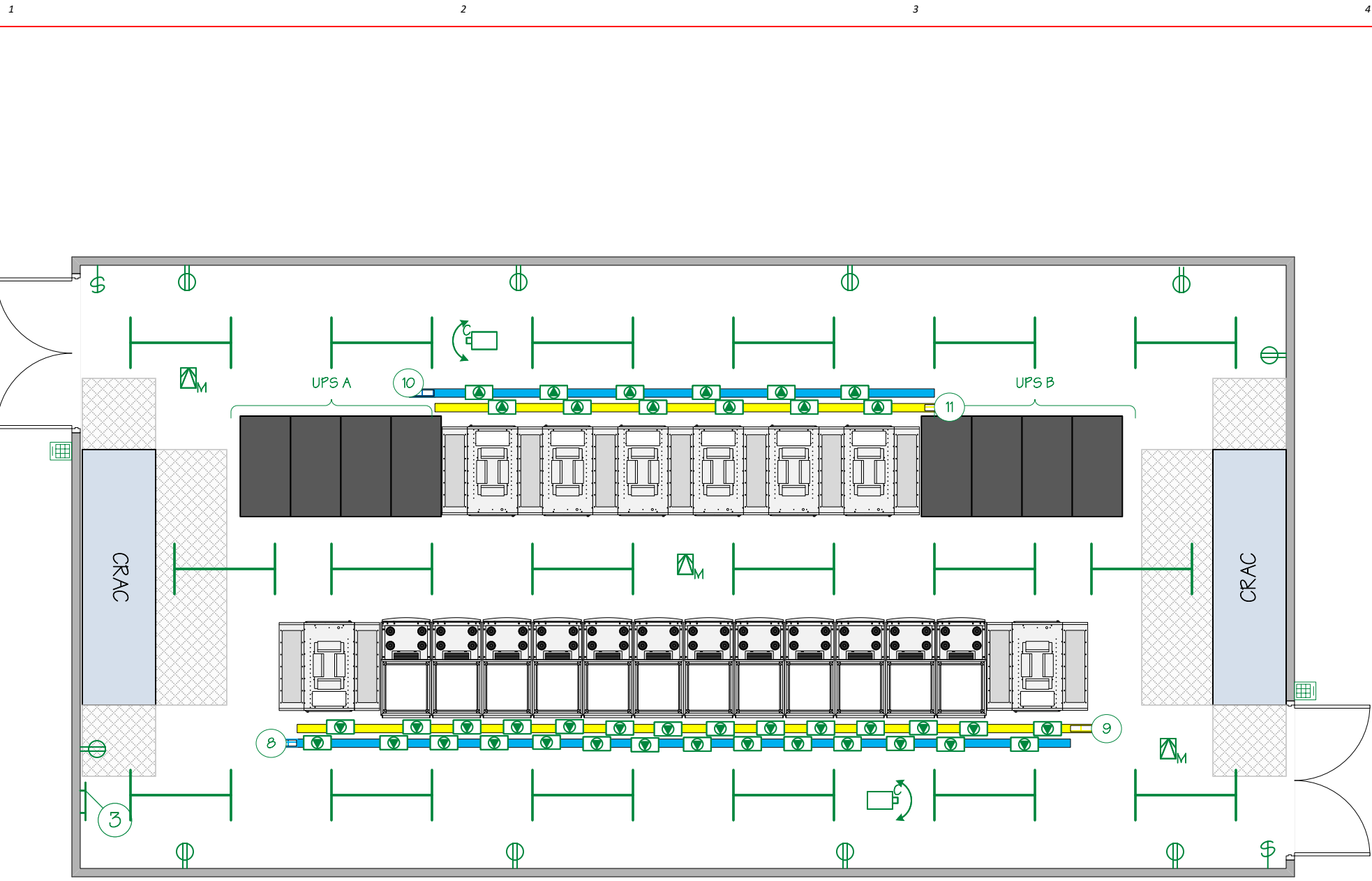

NOTE: SEE THE GENERIC SMALL CAMPUS SUPPORT CENTER (DATA CENTER) DESIGN PORTFOLIO PACKAGE FOR DETAILED IMPLEMENTATION INSTRUCTIONS

1 GENERIC FLOOR PLAN FOR SMALL DATA CENTERS – POWER PLAN (72.9 W/Ft<sup>2</sup>)



PROJECT:

OIT DESIGN GUIDE TEMPLATES

PROJECT No:

N/A

MARK	DATE	DESCRIPTION

ISSUE:

DRAWING No:

FILE: OIT\_Design\_Guide\_Templates-V4 - TD.VSDX

DESIGN BY: KEVIN GRZELKA, CTDC

VERIFIED BY: MICHAEL JULIAN, RCDD  
JOHN WERNAU, KELLY BATES

DOC VERSION No: 4.0

ISSUE DATE: June 1, 2023

SHEET TITLE

SMALL DATA CENTER - POWER

1

2

3

4

D

C

B

A

# TELECOMMUNICATIONS ENCLOSURES

1

2

3

4

DEPARTMENT OF VETERANS  
AFFAIRS



OFFICE OF INFORMATION AND  
TECHNOLOGY

INFRASTRUCTURE OPERATIONS -  
APPLICATION HOSTING, CLOUD AND  
EDGE SOLUTIONS



ENTERPRISE DATA CENTER AND  
INFRASTRUCTURE ENGINEERING

**EDICT**

ENTERPRISE DATA CENTER  
INFRASTRUCTURE COLLABORATION TEAM

PROJECT:

OIT DESIGN GUIDE TEMPLATES

PROJECT No:

N/A

MARK	DATE	DESCRIPTION
------	------	-------------

ISSUE:

DRAWING No:

FILE: OIT\_DESIGN\_GUIDE\_TEMPLATES-V4 - TD.VSDX

DESIGN BY: KEVIN GRZELKA, CTDC

VERIFIED BY: MICHAEL JULIAN, RCDD  
JOHN WERNAU, KELLY BATES

DOC VERSION No: 4.0

ISSUE DATE: June 1, 2023

SHEET TITLE

TELECOMMUNICATIONS  
ENCLOSURE

SHEET: 12 OF 57

ID	PRIMARY ATTRIBUTE	SECONDARY ATTRIBUTE	SPECIFICATION
1	CONSTRUCTION OF TES	SHELL	<ul style="list-style-type: none"> <li>NEMA-12 OR EQUIVALENT</li> <li>TEMPERED GLASS FRONT DOOR</li> <li>DUST SEALS AND REPLACEABLE INLET/OUTLET VENTS/AIRFLOW OPENINGS/FANS</li> </ul>
		ACCESS	<ul style="list-style-type: none"> <li>CABINET SWINGS OPEN TO ACCESS REAR OF INSTALLED EQUIPMENT</li> <li>SWINGING FRONT DOOR TO ACCESS FRONT OF INSTALLED EQUIPMENT</li> <li>BOTH SECTIONS ABLE TO BE PHYSICALLY LOCKED</li> </ul>
		RACKING RAILS	EIA-310-D 19 IN. FRONT AND REAR ADJUSTABLE RAILS
		HEIGHT	<ul style="list-style-type: none"> <li>12 RU FOR UP TO 48 WORK AREA OUTLETS (WAOs)</li> <li>26 RU FOR UP TO 96 WAOs</li> </ul>
		WIDTH	24 IN. MINIMUM
		DEPTH	30 IN. MINIMUM
		MOUNTING	16 IN. ON-CENTER FOR STANDARD STUD CONSTRUCTION
		HEAT DISSIPATION	120V FANS
2	OUTFITTING OF TES	INPUT POWER	A/B REDUNDANT L5-30 120 V 30 A CIRCUITS
		UPS	<ul style="list-style-type: none"> <li>RACK-MOUNTED 2880VA METERED L5-30 INPUT/OUTPUT</li> <li>DUAL/DELTA CONVERSION NOT REQUIRED</li> <li>CONNECTED TO A-SIDE INPUT POWER CIRCUIT</li> </ul>
		RACK POWER DISTRIBUTION	<ul style="list-style-type: none"> <li>A/B REDUNDANT 1RU HORIZONTAL RACK-MOUNTED PDUS</li> <li>L5-30 INPUT, MINIMUM 8 EACH 5-15R OR 5-20R OUTLETS</li> </ul>
		FIBER BACKBONE	<ul style="list-style-type: none"> <li>1 RU FIBER DISTRIBUTION CABINET</li> <li>FLAT CABINET AUTHORIZED</li> </ul>
		HORIZONTAL DISTRIBUTION	<ul style="list-style-type: none"> <li>1 RU UTP PATCH PANELS</li> <li>FLAT PATCH PANELS AUTHORIZED</li> <li>MAXIMUM 1 PATCH PANEL FOR 12 RU TE, TWO PATCH PANELS FOR 26 RU TE</li> </ul>
		NETWORK SWITCHES	<ul style="list-style-type: none"> <li>STANDARD 1RU 48-PORT NETWORK SWITCHES</li> <li>MAXIMUM 1 SWITCH FOR 12 RU TE, TWO SWITCHES FOR 26 RU TE</li> </ul>
		IT EQUIPMENT POWER CORD COLOR CODE	<ul style="list-style-type: none"> <li>A-SIDE: BLACK</li> <li>B-SIDE: A DISTINCTLY DIFFERENT COLOR (WHITE OR GRAY PREFERRED)</li> <li>DIFFERENTIATED BY SOURCE BUS (JACKET OR OTHER MARKING)</li> <li>COMPLY WITH ANY ESTABLISHED LOCAL COLOR SCHEMA</li> </ul>
		IT EQUIPMENT POWER CORD TYPE	<ul style="list-style-type: none"> <li>120V 15 A</li> <li>C13 AT IT EQUIPMENT POWER SUPPLY AND NEMA 5-15 AT RACK PDU</li> </ul>
	BONDING	STANDARD EQUIPMENT AND INTERCONNECTIONS AS PER A TR AND NETWORK CHANNEL RACK	

WALL-MOUNT TE SALIENT CHARACTERISTICS

- NEMA-12 OR EQUIVALENT CONSTRUCTION. DUST SEALS AND REPLACEABLE INLET/OUTLET FILTERS FOR VENTS/AIRFLOW OPENINGS/FANS PROVIDED. THIS IS REQUIRED REGARDLESS OF PLANNED INSTALLATION ENVIRONMENT.
- FILTERS SHALL BE COMMERCIALY WIDELY AVAILABLE AND INITIALLY PROVIDED WITH THE TE.
- ENVIRONMENTALLY CONTROLLED ENCLOSURES ARE ACCEPTABLE; CONSIDER WHEN THE CONDITIONS WHERE THE TE IS TO BE INSTALLED ARE OUTSIDE OF ALLOWABLE TR ENVIRONMENTAL LIMITS.
- 24 IN. MINIMUM WIDTH TO ALLOW FOR POWER AND TELECOMMUNICATIONS CABLING MANAGEMENT TO THE SIDES OF RACK-MOUNTED EQUIPMENT.
- 30 IN. MINIMUM DEPTH TO ALLOW FOR STRUCTURED CABLING AND POWER DISTRIBUTION AT THE REAR OF THE RACK.
- FULL-HEIGHT TES SHALL BE 26 RU IN HEIGHT OR LARGER AS NEEDED TO MEET THE SPECIFIC IMPLEMENTATION REQUIREMENTS. HALF-HEIGHT TES SHALL BE A MINIMUM OF 12 RU IN HEIGHT (24 IN.).
- UNIT MOUNTS TO 3/4 IN. PLYWOOD BACKBOARD VIA 16 IN. ON CENTER (OC) MOUNTING FOR STANDARD STUD CONSTRUCTION.
- UNIT OPENS IN REAR (SWINGS OPEN) FOR ACCESS TO REAR OF INSTALLED EQUIPMENT. UNIT OPENS IN FRONT (SWINGING FRONT DOOR) FOR ACCESS TO FRONT OF INSTALLED EQUIPMENT. BOTH SECTIONS ARE ABLE TO BE PHYSICALLY LOCKED.
- ADJUSTABLE 19 IN. EIA/TIA RACK RAILS. REAR RAIL KITS ARE REQUIRED.
- TOP AND BOTTOM KNOCKOUTS FOR CABLE/CONDUIT ENTRY. ALL KNOCKOUTS MUST BE SEALABLE AND SEALED FOR LIQUID AND DUST ENTRY RESISTANCE. THE USE OF A KNOCKOUT KIT TO CREATE LARGER PENETRATIONS IS ACCEPTABLE.
- 120 V FANS TO REMOVE HEAT GENERATED IN TE ARE REQUIRED. WHETHER THESE ARE USED AS EXHAUST, INTAKE, OR BOTH IS NOT SPECIFIED.
- PROVIDE TES WITH FIBER DISTRIBUTION CABINETS, FIBER CASSETTES, UTP PATCH PANELS, HORIZONTAL CABLE MANAGEMENT UNITS, AND SHELVES AS REQUIRED FOR THE SPECIFIC IMPLEMENTATION.

1 ATTRIBUTES AND SALIENT CHARACTERISTICS FOR TELECOMMUNICATIONS ENCLOSURES (TEs) NTS



PROJECT:

OIT DESIGN GUIDE TEMPLATES

PROJECT No:

N/A

MARK	DATE	DESCRIPTION

ISSUE:

DRAWING No:

FILE: OIT\_DESIGN\_GUIDE\_TEMPLATES-V4-TD.VSDX

DESIGN BY: KEVIN GRZELKA, CTDC

VERIFIED BY: MICHAEL JULIAN, RCDD JOHN WERNAU, KELLY BATES

DOC VERSION No: 4.0

ISSUE DATE: June 1, 2023

SHEET TITLE

TELECOMMUNICATIONS ENCLOSURE ATTRIBUTES

1

2

3

4

D

C

B

A

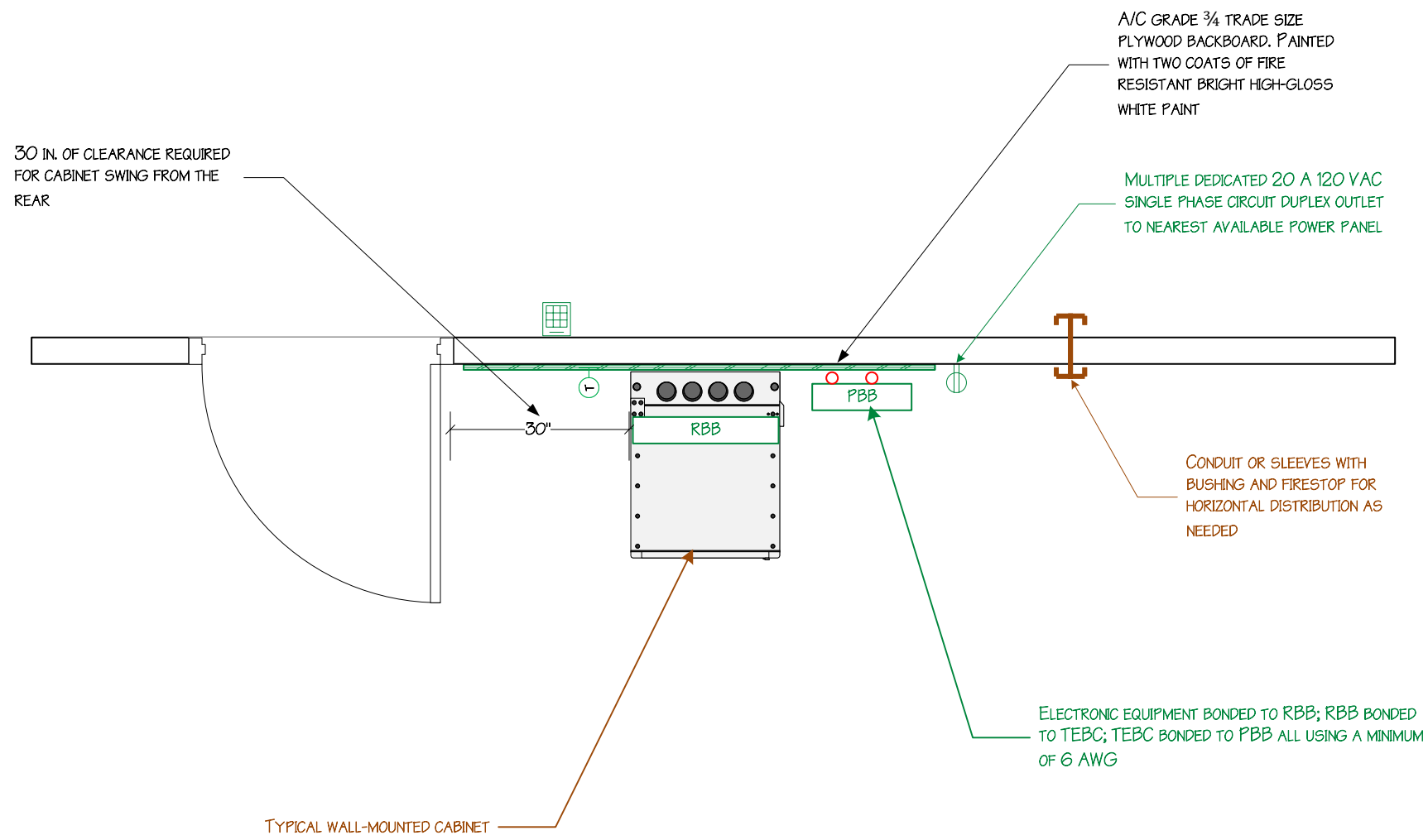

1 TYPICAL TOP-DOWN VIEW  
NTS

1

2

3

4

DEPARTMENT OF VETERANS AFFAIRS



OFFICE OF INFORMATION AND TECHNOLOGY

INFRASTRUCTURE OPERATIONS - APPLICATION HOSTING, CLOUD AND EDGE SOLUTIONS



ENTERPRISE DATA CENTER AND INFRASTRUCTURE ENGINEERING

EDCT

ENTERPRISE DATA CENTER INFRASTRUCTURE COLLABORATION TEAM

PROJECT:

OIT DESIGN GUIDE TEMPLATES

PROJECT No:

N/A

MARK	DATE	DESCRIPTION
------	------	-------------

ISSUE:

DRAWING No:

FILE: OIT\_Design\_Guide\_Templates-V4 - TD.VSDX

DESIGN BY: KEVIN GRZELKA, CTDC

VERIFIED BY: MICHAEL JULIAN, RCDD  
JOHN WERNAU, KELLY BATES

DOC VERSION No: 4.0

ISSUE DATE: June 1, 2023

SHEET TITLE

TELECOMMUNICATIONS ENCLOSURE TOP VIEW



LOCKING 120 V 30 A OUTLETS (L5-30) ON THE WALL BEHIND THE RACK ALIGNED WITH THE CUTOUT ON THE ENCLOSURE. ONE OUTLET ASSIGNED TO PDU. ONE OUTLET ASSIGNED TO UPS. EACH ENERGIZED BY SEPARATE ONE-POLE 30 A BREAKERS.

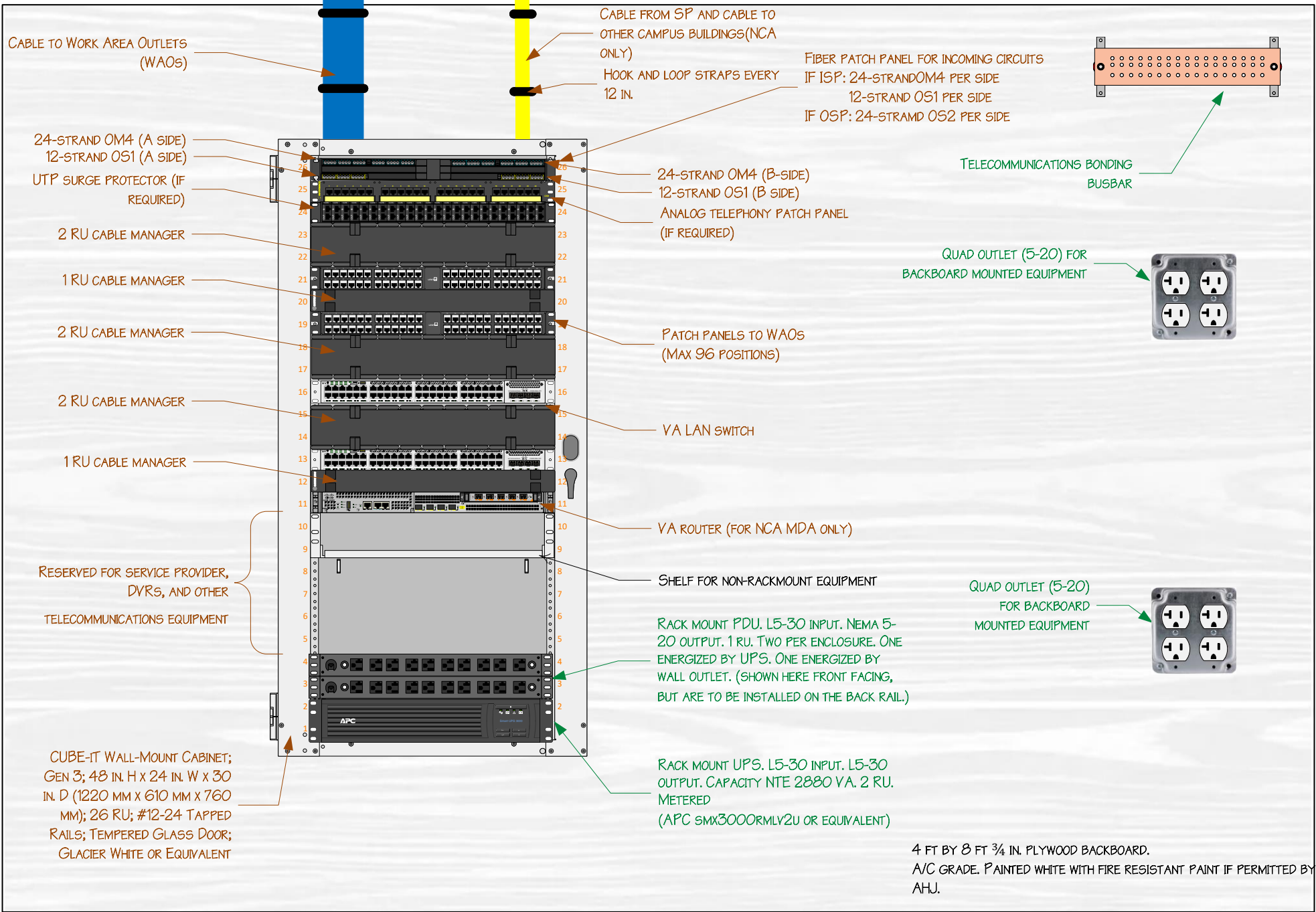

1 ELEVATION FOR 26 RU ENCLOSURE  
NTS



PROJECT:

OIT DESIGN GUIDE TEMPLATES

PROJECT No:

N/A

MARK	DATE	DESCRIPTION

ISSUE:

DRAWING No:

FILE: OIT\_Design\_Guide\_Templates-V4 - TD.VSDX

DESIGN BY: KEVIN GRZELKA, CTDC

VERIFIED BY: MICHAEL JULIAN, RCDD  
JOHN WERNAU, KELLY BATES

DOC VERSION No: 4.0

ISSUE DATE: June 1, 2023

SHEET TITLE

TE 26RU ELEVATION

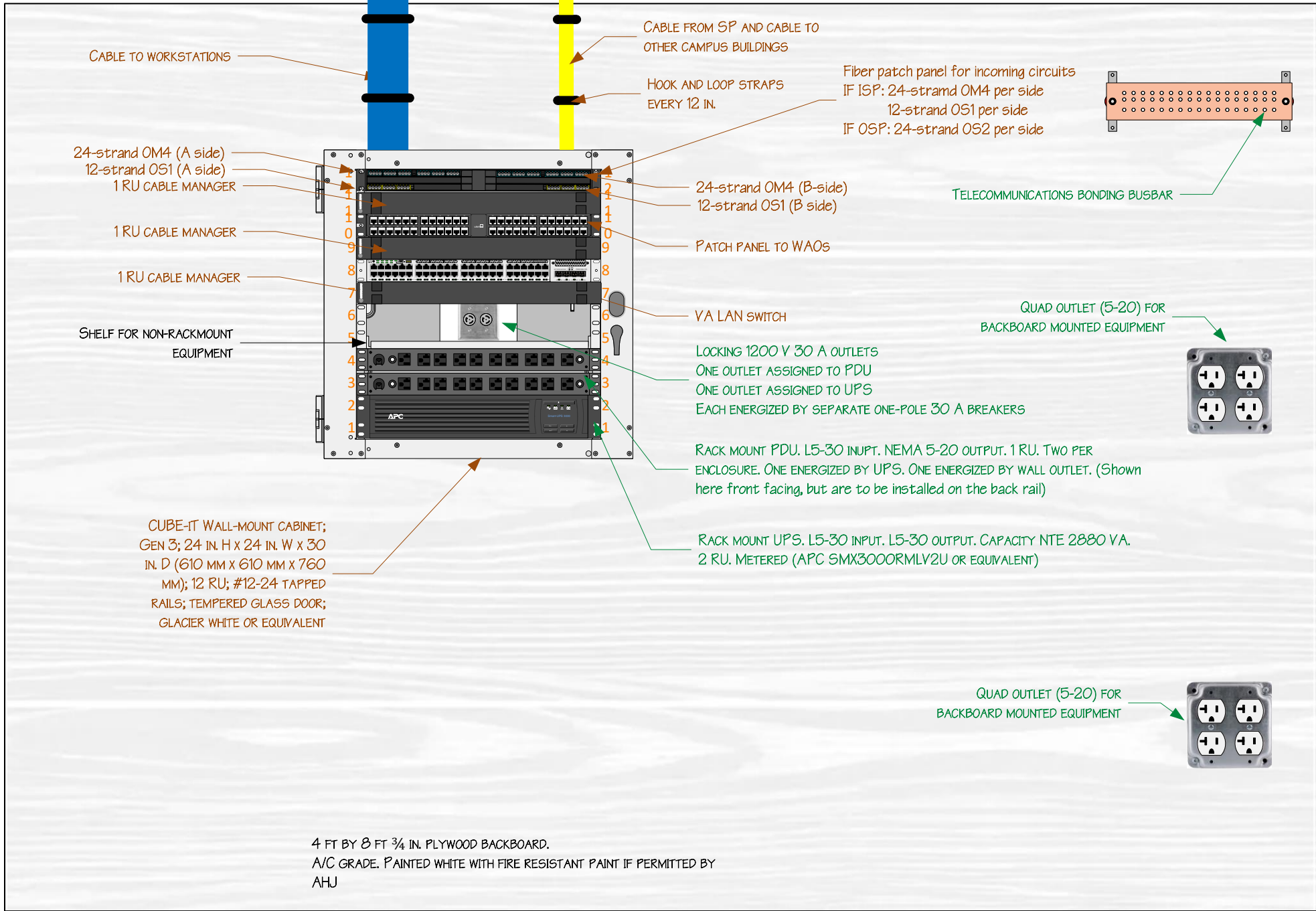

1 ELEVATION FOR 12 RU ENCLOSURE  
NTS



MARK	DATE	DESCRIPTION
------	------	-------------

ISSUE:

DRAWING No:  
FILE: OIT\_Design\_Guide\_Templates-V4 - TD.VSDX  
DESIGN BY: KEVIN GRZELKA, CTDC  
VERIFIED BY: MICHAEL JULIAN, RCDD  
JOHN WERNAU, KELLY BATES  
DOC VERSION No: 4.0  
ISSUE DATE: June 1, 2023

SHEET TITLE  
  
TE 12RU ELEVATION



1

2

3

4

D

C

B

A

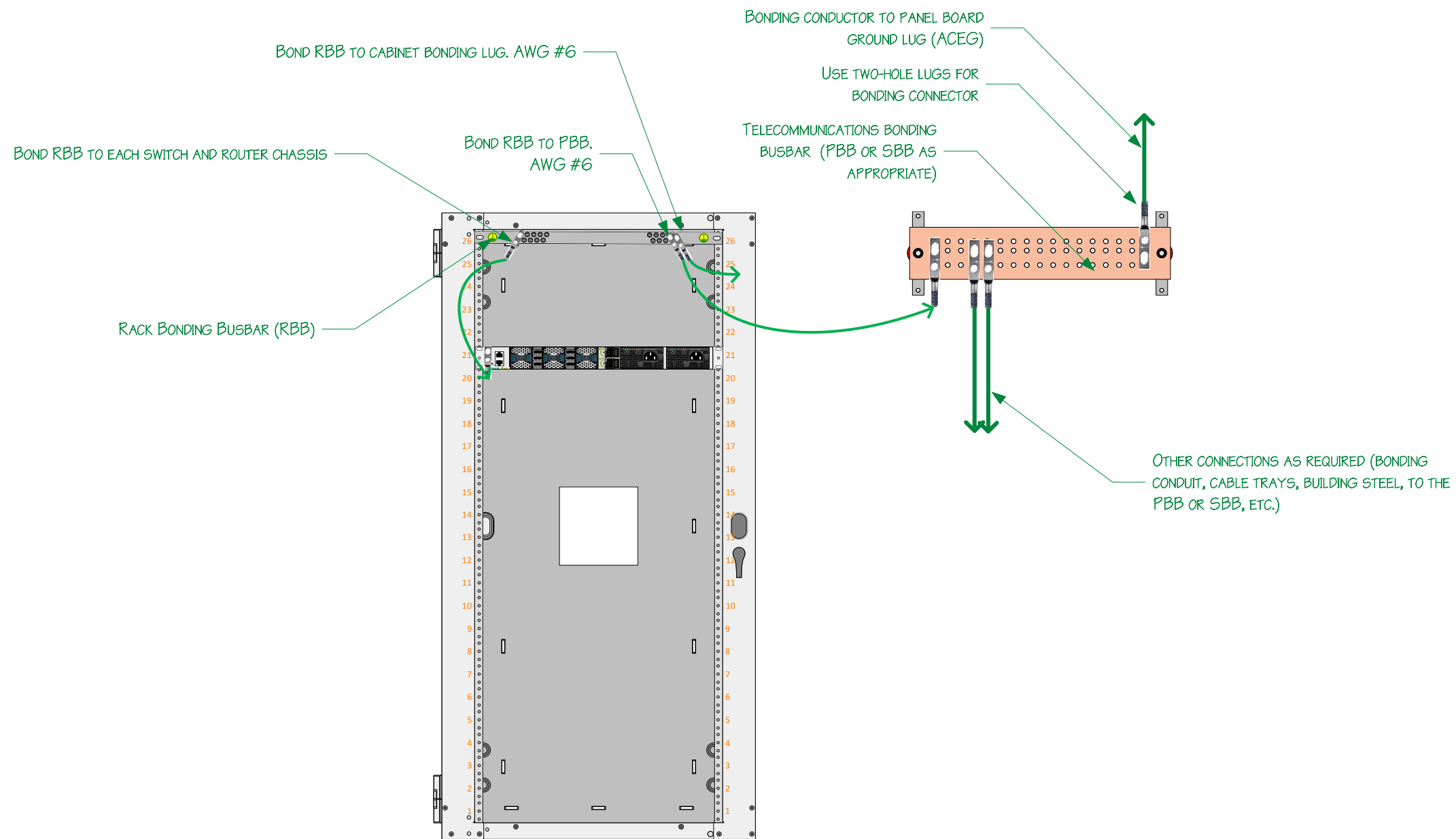

① BONDING TOPOLOGY FOR TELECOMMUNICATIONS ENCLOSURES  
NTS

1

2

3

4

DEPARTMENT OF VETERANS AFFAIRS

OFFICE OF INFORMATION AND TECHNOLOGY

INFRASTRUCTURE OPERATIONS - APPLICATION HOSTING, CLOUD AND EDGE SOLUTIONS

ENTERPRISE DATA CENTER AND INFRASTRUCTURE ENGINEERING

**EDCT**  
ENTERPRISE DATA CENTER INFRASTRUCTURE COLLABORATION TEAM

**PROJECT:**  
OIT DESIGN GUIDE TEMPLATES

PROJECT No:  
N/A

MARK	DATE	DESCRIPTION

ISSUE:

DRAWING No:  
FILE: OIT\_DESIGN\_GUIDE\_TEMPLATES-V4 - TD.VSDX  
DESIGN BY: KEVIN GRZELKA, CTDC  
VERIFIED BY: MICHAEL JULIAN, RCDD  
JOHN WERNAU, KELLY BATES  
DOC VERSION No: 4.0  
ISSUE DATE: June 1, 2023

SHEET TITLE

TE BONDING

SHEET: 17 OF 57

D

C

B

A

1

2

3

4

D

C

B

A

# ELECTRICAL DISTRIBUTION AND BONDING

1

2

3

4

DEPARTMENT OF VETERANS  
AFFAIRS



OFFICE OF INFORMATION AND  
TECHNOLOGY

INFRASTRUCTURE OPERATIONS -  
APPLICATION HOSTING, CLOUD AND  
EDGE SOLUTIONS



ENTERPRISE DATA CENTER AND  
INFRASTRUCTURE ENGINEERING

**EDICT**

ENTERPRISE DATA CENTER  
INFRASTRUCTURE COLLABORATION TEAM

PROJECT:

OIT DESIGN GUIDE TEMPLATES

PROJECT No:

N/A

MARK	DATE	DESCRIPTION

ISSUE:

DRAWING No:

FILE: OIT\_DESIGN\_GUIDE\_TEMPLATES-V4 -  
TD.VSDX

DESIGN BY: KEVIN GRZELKA, CTDC

VERIFIED BY: MICHAEL JULIAN, RCDD  
JOHN WERNAU, KELLY BATES

DOC VERSION No: 4.0

ISSUE DATE: June 1, 2023

SHEET TITLE

**ELECTRICAL DISTRIBUTION  
AND BONDING**

SHEET: 18 OF 57

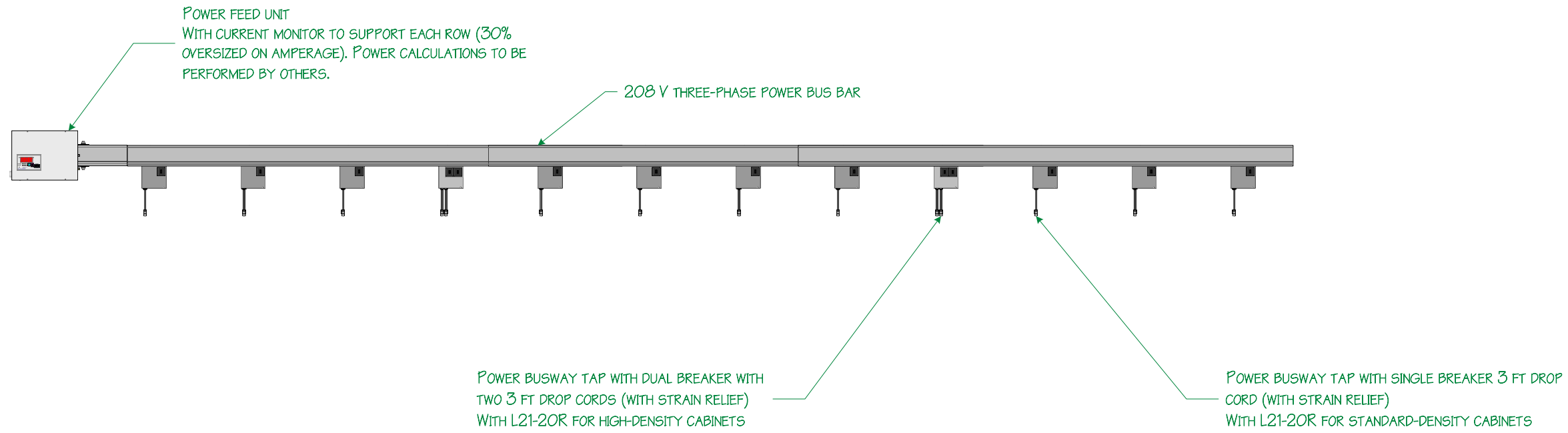

② TYPICAL POWER BUSWAY COMPONENTS FOR SERVER ROWS

THIS DESIGN PROVIDES DIVERSE POWER INPUTS FOR ACTIVE EQUIPMENT BY SPLITTING THE SOURCE POWER ACROSS TWO BUSWAYS. EACH SERVER CABINET WILL CONTAIN A MINIMUM OF TWO EQUIPMENT-FACING ZERO U VERTICAL RACK PDUS – EACH WILL BE ENERGIZED BY SEPARATE BUSWAY TAP INPUTS ON DISPARATE BUSWAYS.

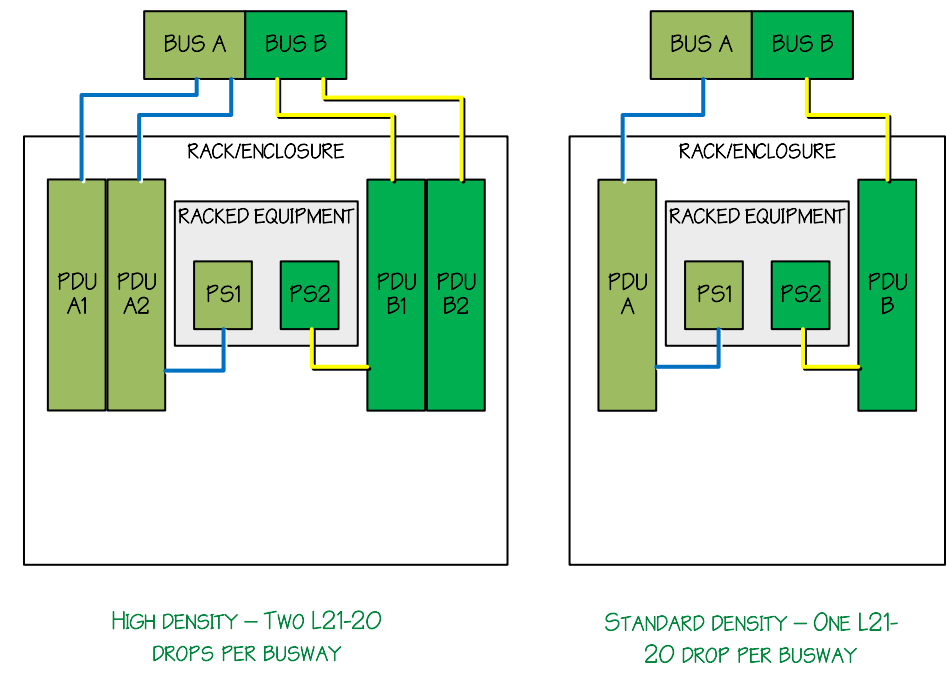

① POWER SCHEMATIC FOR POWER RACK- LEVEL REDUNDANCY



PROJECT:

OIT DESIGN GUIDE TEMPLATES

PROJECT No:

N/A

MARK	DATE	DESCRIPTION

ISSUE:

DRAWING No:	
FILE:	OIT_Design_Guide_Templates-V4 - TD.VSDX
DESIGN BY:	KEVIN GRZELKA, CTDC
VERIFIED BY:	MICHAEL JULIAN, RCDD JOHN WERNAU, KELLY BATES
DOC VERSION No:	4.0
ISSUE DATE:	June 1, 2023

SHEET TITLE

BUSWAY POWER DISTRIBUTION

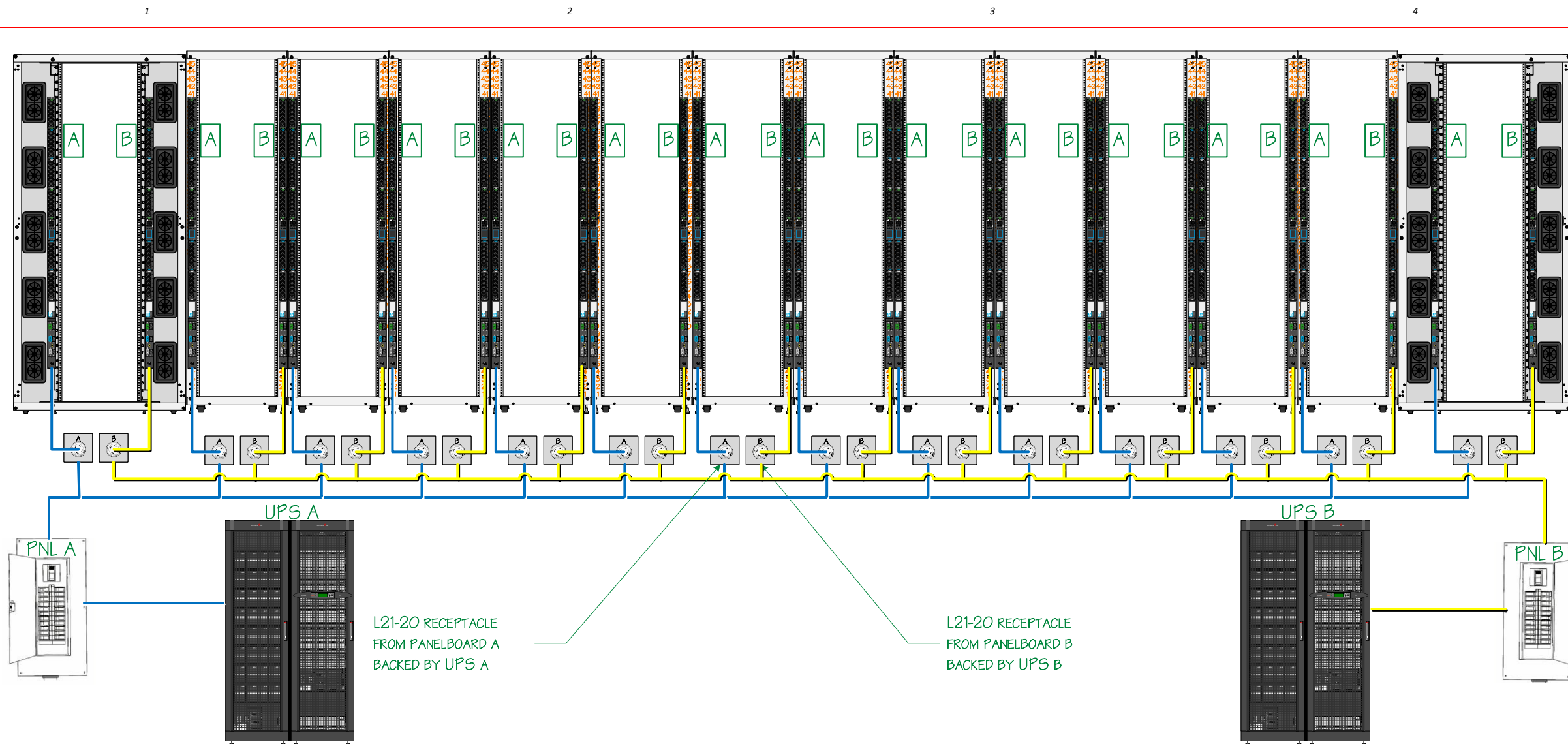

2 TYPICAL BRANCH CIRCUIT COMPONENTS FOR SERVER ROWS

THIS DESIGN PROVIDES DIVERSE POWER INPUTS FOR ACTIVE EQUIPMENT BY SPLITTING THE SOURCE POWER ACROSS TWO BRANCH CIRCUITS. EACH SERVER CABINET WILL CONTAIN A MINIMUM OF TWO EQUIPMENT-FACING ZERO U VERTICAL RACK PDUs – EACH WILL BE ENERGIZED BY SEPARATE BRANCH CIRCUIT INPUTS ON DISPARATE PANELBOARDS BACKED BY SEPARATE UPS

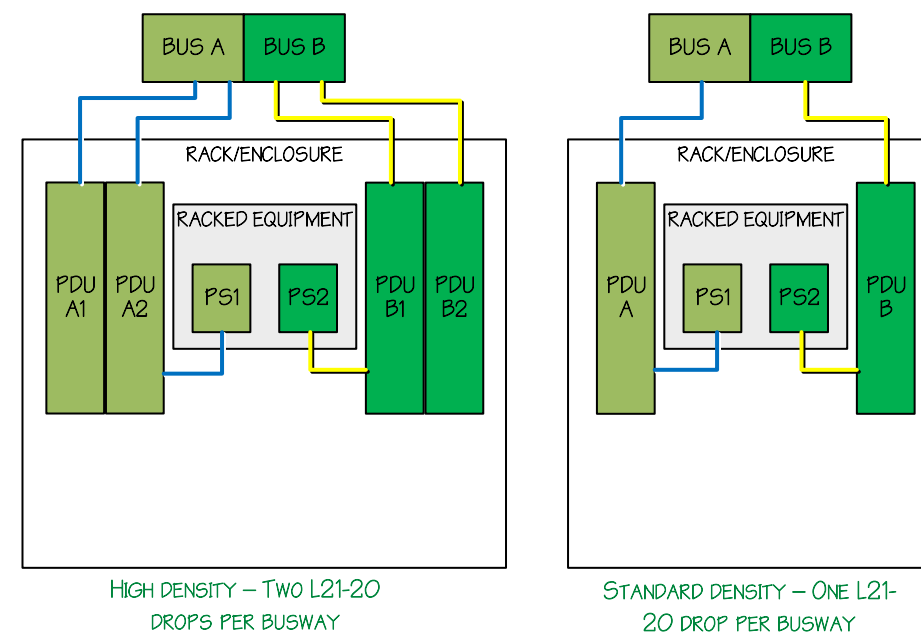

1 POWER SCHEMATIC FOR POWER RACK- LEVEL REDUNDANCY



PROJECT:

OIT DESIGN GUIDE TEMPLATES

PROJECT No:

N/A

MARK	DATE	DESCRIPTION

ISSUE:

DRAWING No:

FILE: OIT\_Design\_Guide\_Templates-V4 - TD.VSDX

DESIGN BY: KEVIN GRZELKA, CTDC

VERIFIED BY: MICHAEL JULIAN, RCDD  
JOHN WERNAU, KELLY BATES

DOC VERSION No: 4.0

ISSUE DATE: June 1, 2023

SHEET TITLE

BRANCH CIRCUIT POWER DISTRIBUTION

THIS DESIGN PROVIDES DIVERSE POWER INPUTS FOR ACTIVE EQUIPMENT BY SPLITTING THE SOURCE POWER ACROSS TWO ZONE PDU INPUTS. EACH SERVER CABINET WILL CONTAIN A MINIMUM OF TWO EQUIPMENT-FACING ZERO U VERTICAL RACK PDUS – EACH WILL BE ENERGIZED BY SEPARATE ZONE PDU INPUTS.

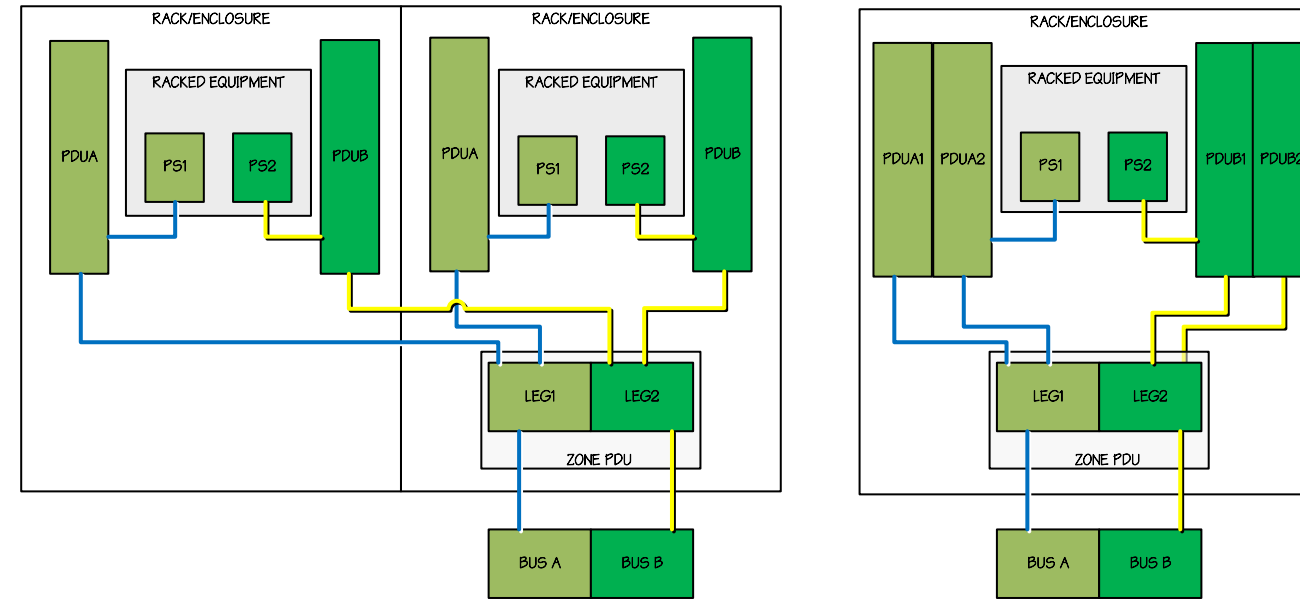

STANDARD DENSITY – ONE ZONE PDU PER TWO RACKS

HIGH DENSITY – ONE ZONE PDU PER RACK

2 POWER SCHEMATIC FOR POWER RACK- LEVEL REDUNDANCY

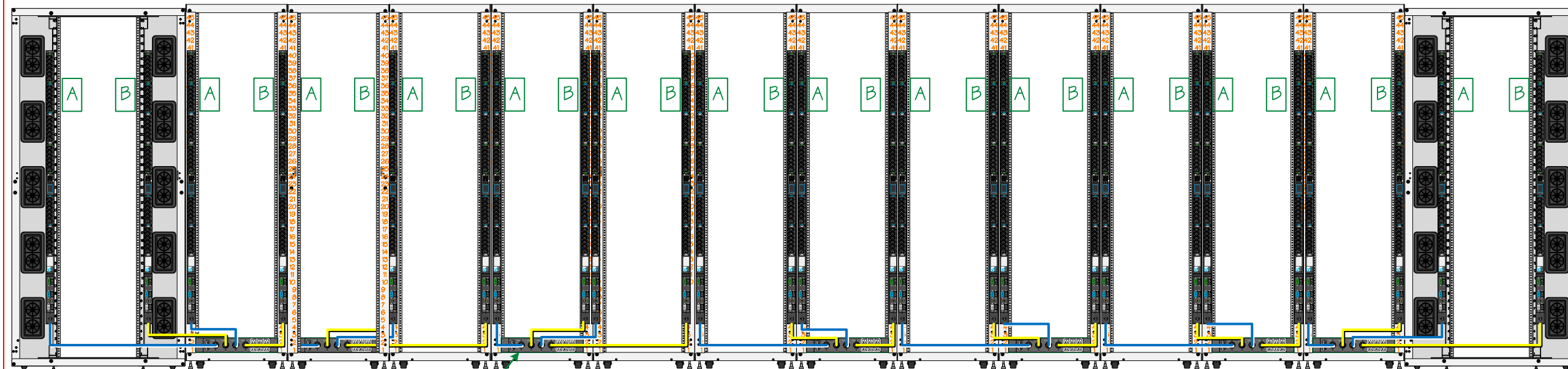

SEVEN ZONE PDUS PER SERVER ROW

NOTE: MDA ROWS FOLLOW THE SAME SCHEMA WITH ONE ZONE PDU PER TWO STANDARD RACKS/CABINETS AND ONE FOR EACH HIGH DENSITY CABINET.

NOTE: 30A ZONE POWER DISTRIBUTION IS TYPICALLY USED IN LEGACY COMPUTER ROOMS WITH A RAISED ACCESS FLOOR USED FOR COOLING AIR DISTRIBUTION. ENCLOSURE DENSITIES ARE LIMITED TO 3.5 KW (SD) AND 7 KW (HD) IN THESE TYPES OF ENVIRONMENTS.

1 SUBZONE TO 30A ZONE PDU CONNECTION MAP FOR TYPICAL (14 RACK) SERVER ROWS



PROJECT:

OIT DESIGN GUIDE TEMPLATES

PROJECT No:

N/A

MARK	DATE	DESCRIPTION

ISSUE:

DRAWING No:

FILE: OIT\_Design\_Guide\_Templates-V4 - TD.VSDX

DESIGN BY: KEVIN GRZELKA, CTDC

VERIFIED BY: MICHAEL JULIAN, RCDD  
JOHN WERNAU, KELLY BATES

DOC VERSION No: 4.0

ISSUE DATE: June 1, 2023

SHEET TITLE

30A ZONE PDU POWER DISTRIBUTION

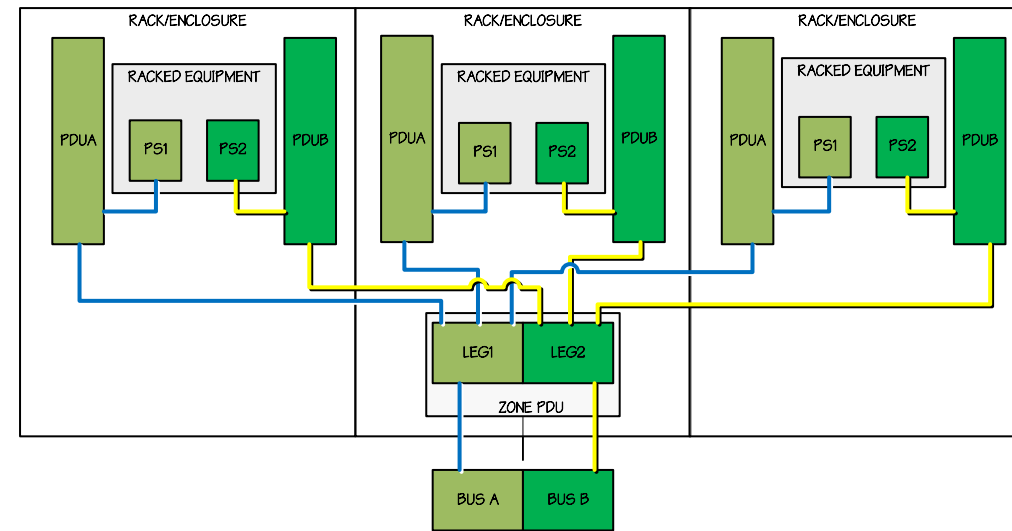

ONE ZONE PDU FOR THREE STANDARD DENSITY SERVER CABINETS/NETWORK RACKS

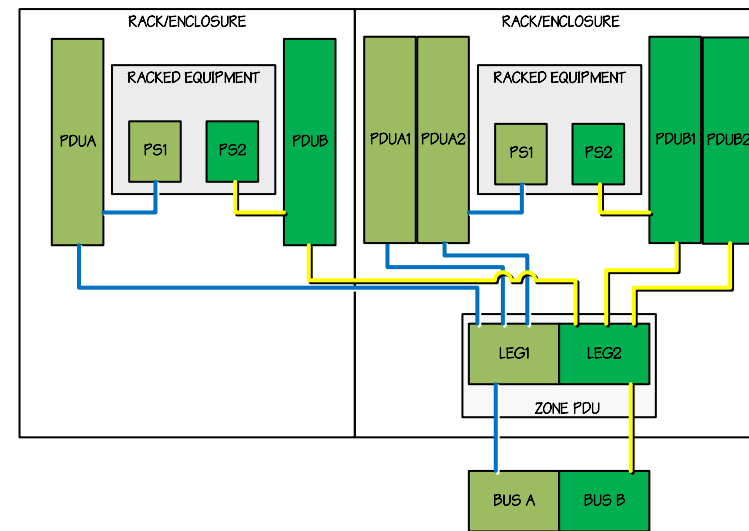

ONE ZONE PDU FOR ONE STANDARD DENSITY SERVER CABINET AND ONE HIGH DENSITY SERVER CABINET

NOTE: THIS DESIGN PROVIDES DIVERSE POWER INPUTS FOR ACTIVE EQUIPMENT BY SPLITTING THE SOURCE POWER ACROSS TWO INPUTS ON THE ZONE PDU. EACH INPUT WILL SUPPORT THREE EQUIPMENT-FACING RACK PDUS. EACH SERVER CABINET WILL CONTAIN A MINIMUM OF TWO EQUIPMENT-FACING PDUS – EACH WILL BE ENERGIZED BY SEPARATE ZONE PDU INPUTS.

② POWER SCHEMATIC FOR POWER RACK- LEVEL REDUNDANCY

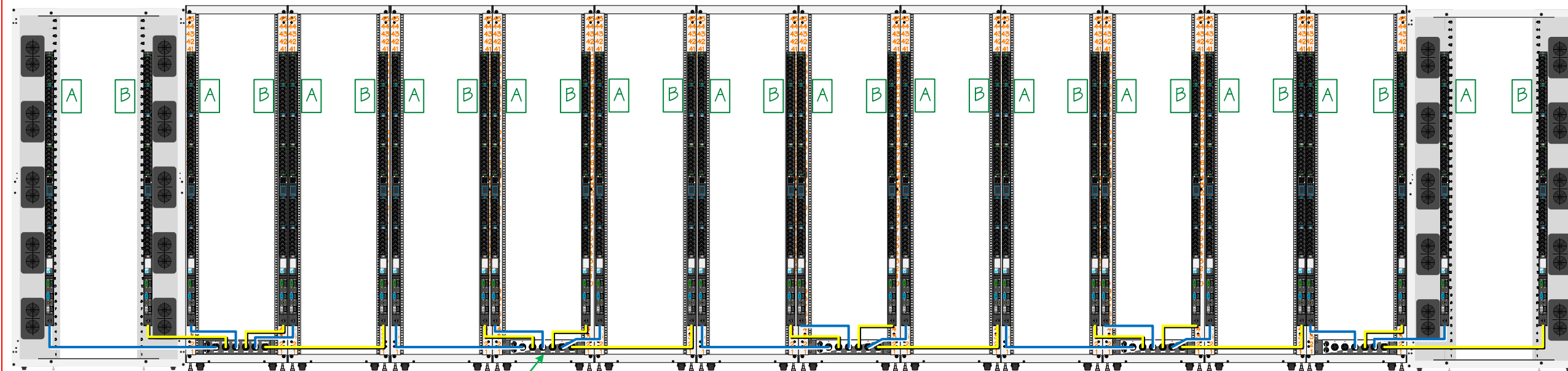

FIVE ZONE PDUS PER ROW

NOTE: MDA ROWS FOLLOW THE SAME SCHEMA WITH ONE ZONE PDU PER THREE STANDARD RACKS/CABINETS AND ONE FOR EACH SET OF ONE HIGH DENSITY CABINET AND ONE STANDARD DENSITY CABINET

① SUBZONE TO 60A ZONE PDU CONNECTION MAP FOR TYPICAL (14 RACK) SERVER ROWS



PROJECT:

OIT DESIGN GUIDE TEMPLATES

PROJECT No:

N/A

MARK	DATE	DESCRIPTION

ISSUE:

DRAWING No:

FILE: OIT\_Design\_Guide\_Templates-V4 - TD.VSDX

DESIGN BY: KEVIN GRZELKA, CTDC

VERIFIED BY: MICHAEL JULIAN, RCDD  
JOHN WERNAU, KELLY BATES

DOC VERSION No: 4.0

ISSUE DATE: June 1, 2023

SHEET TITLE

60A ZONE PDU POWER DISTRIBUTION

SIDE A  
REQUIRES A 208 V, 60 A, THREE-PHASE CIRCUIT, TERMINATING IN A HARD-WIRED JUNCTION BOX

SIDE B  
REQUIRES A 208 V, 60 A, THREE-PHASE CIRCUIT, TERMINATING IN A HARD-WIRED JUNCTION BOX

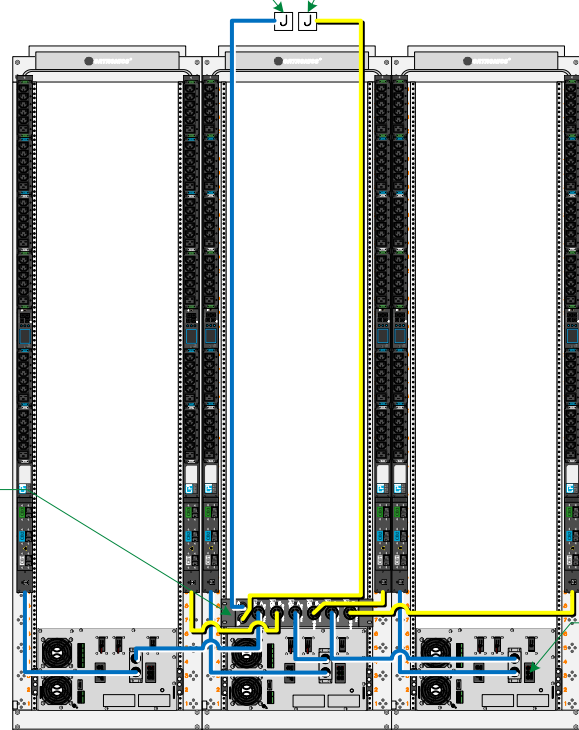

ZONE PDU  
60 A 3-PHASE ZONE PDU BASE UNIT –  
REQUIRES TWO 60 A 3-PHASE (WYE)  
CIRCUITS HARD-WIRED IN JUNCTION BOX;  
OPTIONALLY, UPSs AND B-SIDE RPDUs  
MAY BE POWERED DIRECTLY WITH L21-20  
OUTLETS

RACK-MOUNTED 5 kW, 208 V  
UNINTERRUPTIBLE POWER SUPPLY (UPS)  
WITH NEMA 20A L21-20P INPUT AND L21-  
20R OUTPUT

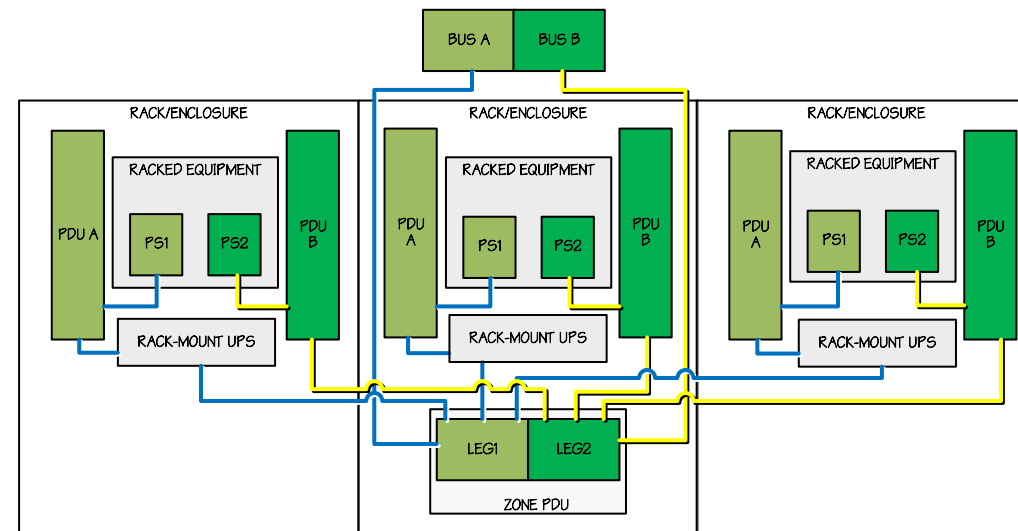

③ POWER ELEVATION AND SCHEMATIC FOR A THREE RACK TR

L21-30P SIDE A  
REQUIRES A 208 V, 30 A, THREE-PHASE CIRCUIT,  
TERMINATING IN A NEMA L21-30R LOCKING  
RECEPTACLE

L21-30P SIDE B  
REQUIRES A 208 V, 30 A, THREE-PHASE CIRCUIT,  
TERMINATING IN A NEMA L21-30R LOCKING  
RECEPTACLE



ZONE PDU  
30 A THREE-PHASE ZONE PDU BASE UNIT  
– REQUIRES TWO 30 A THREE-PHASE  
(WYE) CIRCUITS WITH L21-30R  
RECEPTACLES; OPTIONALLY, UPSs AND B-  
SIDE RPDUs MAY BE POWERED DIRECTLY  
WITH L21-20 OUTLETS

RACK-MOUNTED 5 kW, 208 V UPS WITH NEMA  
20 A L21-20P INPUT AND L21-20R OUTPUT

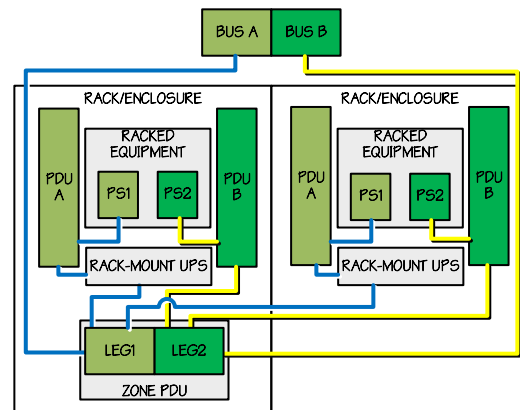

② POWER ELEVATION AND SCHEMATIC FOR A TWO RACK TR

L21-20P SIDE A  
REQUIRES A 208 V, 20 A, THREE-  
PHASE CIRCUIT, TERMINATING IN A  
NEMA L21-20R LOCKING  
RECEPTACLE

L21-20P SIDE B  
REQUIRES A 208 V, 20 A, THREE-  
PHASE CIRCUIT, TERMINATING IN A  
NEMA L21-20R LOCKING  
RECEPTACLE

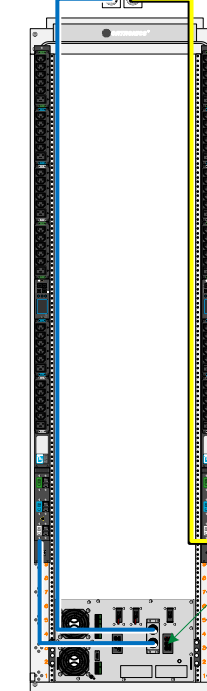

RACK-MOUNTED 5 kW, 208 V  
UPS WITH NEMA 20A L21-  
20P INPUT AND L21-20R  
OUTPUT

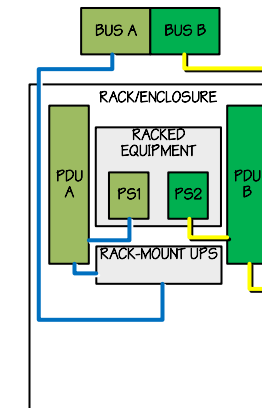

① POWER ELEVATION AND SCHEMATIC FOR A ONE RACK TR



PROJECT:

OIT DESIGN GUIDE TEMPLATES

PROJECT No:

N/A

MARK	DATE	DESCRIPTION

ISSUE:

DRAWING No:

FILE: OIT\_Design\_Guide\_Templates-V4 -  
TD.VSDX

DESIGN BY: KEVIN GRZELKA, CTDC

VERIFIED BY: MICHAEL JULIAN, RCDD  
JOHN WERNAU, KELLY BATES

DOC VERSION No: 4.0

ISSUE DATE: June 1, 2023

SHEET TITLE

ZONE PDU POWER DISTRIBUTION  
IN TRS

SHEET: 23 OF 57

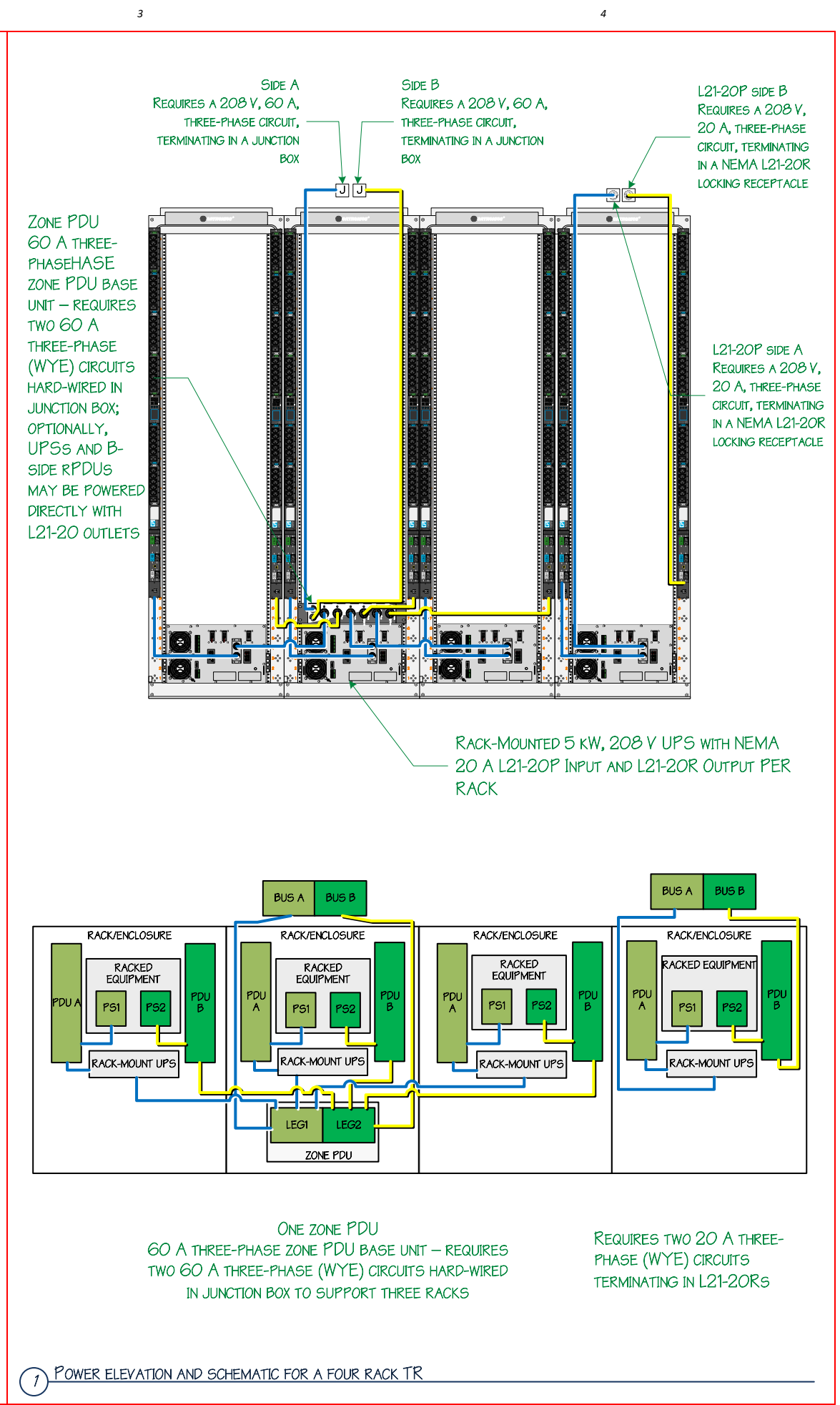
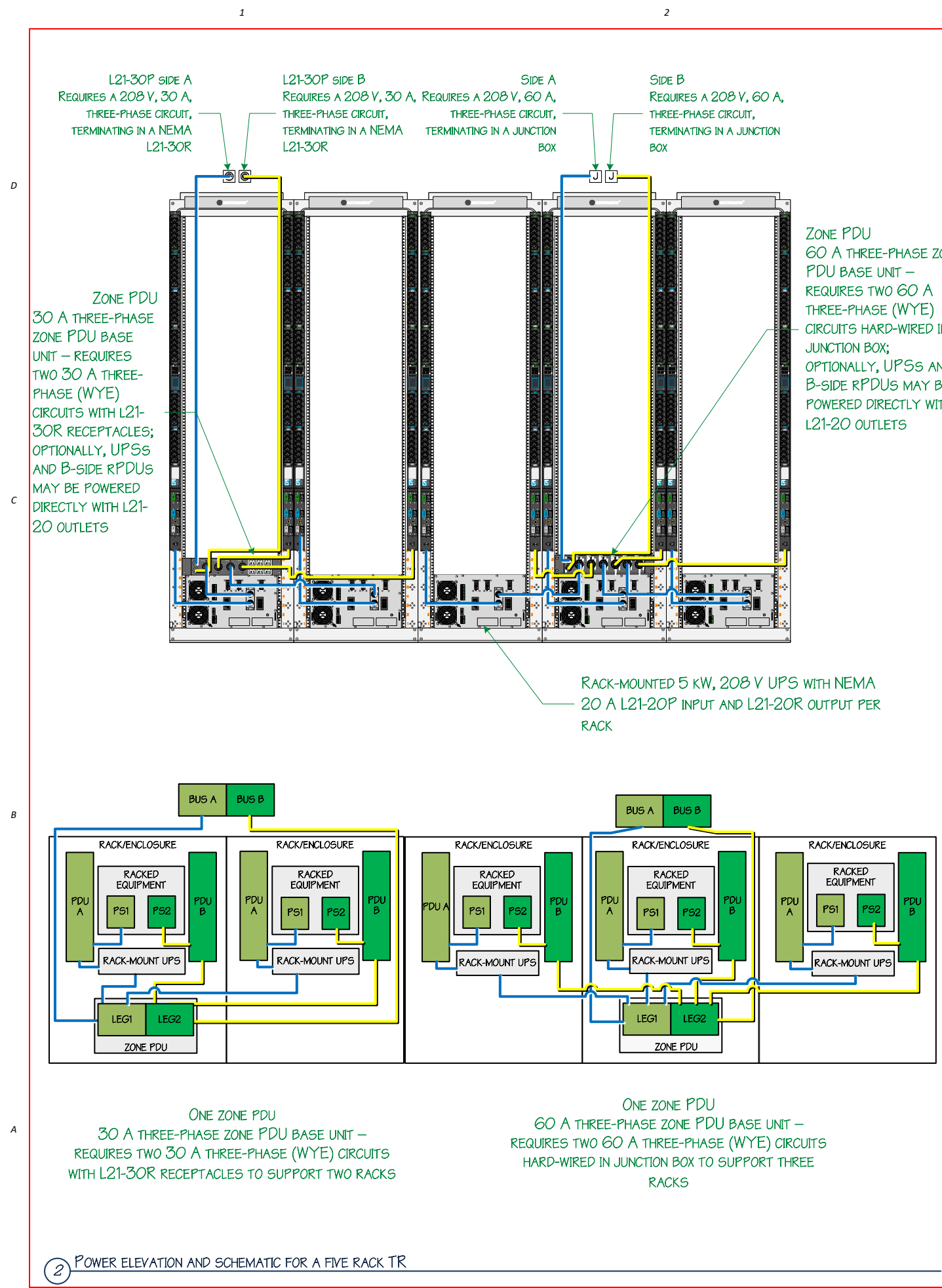

DEPARTMENT OF VETERANS  
AFFAIRS

OFFICE OF INFORMATION AND  
TECHNOLOGY

INFRASTRUCTURE OPERATIONS -  
APPLICATION HOSTING, CLOUD AND  
EDGE SOLUTIONS

ENTERPRISE DATA CENTER AND  
INFRASTRUCTURE ENGINEERING

EDCT  
ENTERPRISE DATA CENTER  
INFRASTRUCTURE COLLABORATION TEAM

PROJECT:  
OIT DESIGN GUIDE TEMPLATES

PROJECT No:  
N/A

MARK	DATE	DESCRIPTION

ISSUE:

DRAWING No:  
FILE: OIT\_Design\_Guide\_Templates-V4 -  
TD.VSDX

DESIGN BY: KEVIN GRZELKA, CTDC

VERIFIED BY: MICHAEL JULIAN, RCDD  
JOHN WERNAU, KELLY BATES

DOC VERSION No: 4.0

ISSUE DATE: June 1, 2023

SHEET TITLE

ZONE PDU POWER DISTRIBUTION  
IN FOUR AND FIVE RACK TRs

SHEET: 24 OF 57



1

2

3

4

D

C

B

A

SIDE A  
REQUIRES A 208 V, 60 A, THREE-PHASE CIRCUIT, TERMINATING IN A HARD-WIRED JUNCTION BOX

SIDE B  
REQUIRES A 208 V, 60 A, THREE-PHASE CIRCUIT, TERMINATING IN A HARD-WIRED JUNCTION BOX

ZONE PDU  
60 A THREE-PHASE ZONE PDU BASE UNIT –  
REQUIRES TWO 60 A THREE-PHASE (WYE) CIRCUITS  
HARD-WIRED IN JUNCTION BOX; OPTIONALLY, UPSs  
MAY BE POWERED DIRECTLY WITH L21-20 OUTLETS

RACK-MOUNTED 5 KW, 208 V UPS WITH NEMA  
20 A L21-20P INPUT AND L21-20R OUTPUT

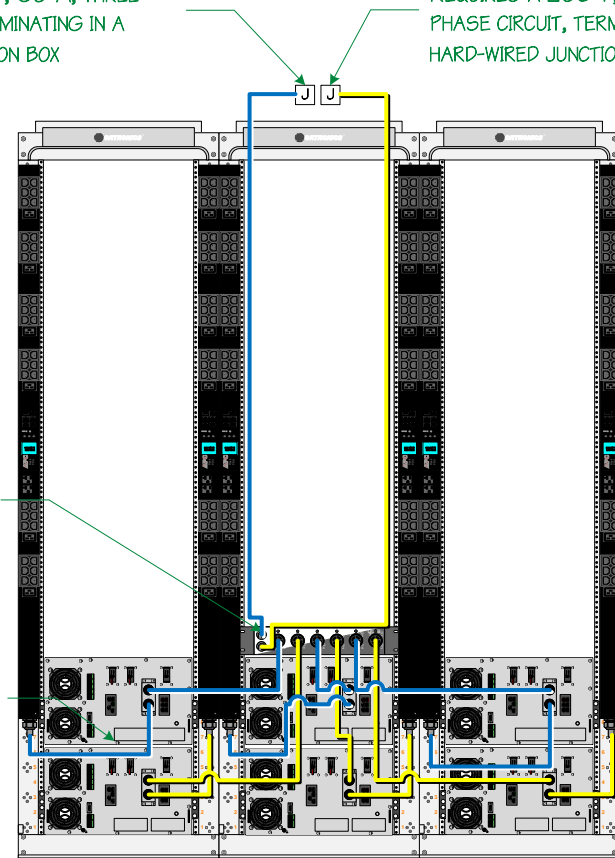

2 POWER ELEVATION FOR A HEALTH CARE FACILITY ENTRANCE ROOM

1

2

3

4

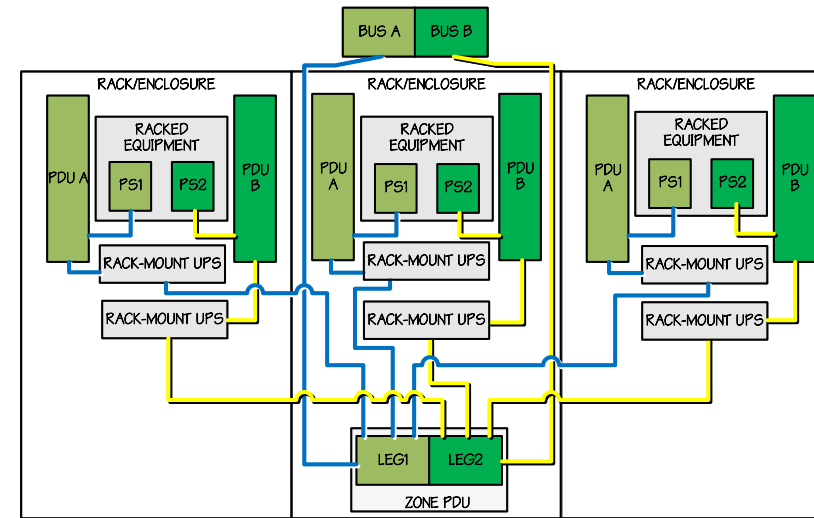

ONE ZONE PDU  
60 A THREE-PHASE ZONE PDU BASE UNIT –  
REQUIRES TWO 60 A THREE-PHASE (WYE) CIRCUITS  
HARD-WIRED IN JUNCTION BOX TO SUPPORT THREE  
RACKS

1 POWER SCHEMATIC FOR A HEALTH CARE FACILITY ENTRANCE ROOM

DEPARTMENT OF VETERANS  
AFFAIRS



OFFICE OF INFORMATION AND  
TECHNOLOGY

INFRASTRUCTURE OPERATIONS -  
APPLICATION HOSTING, CLOUD AND  
EDGE SOLUTIONS



ENTERPRISE DATA CENTER AND  
INFRASTRUCTURE ENGINEERING

EDCT

ENTERPRISE DATA CENTER  
INFRASTRUCTURE COLLABORATION TEAM

PROJECT:

OIT DESIGN GUIDE TEMPLATES

PROJECT No:

N/A

MARK	DATE	DESCRIPTION
------	------	-------------

ISSUE:

DRAWING No:

FILE: OIT\_Design\_Guide\_Templates-V4 -  
TD.VSDX

DESIGN BY: KEVIN GRZELKA, CTDC

VERIFIED BY: MICHAEL JULIAN, RCDD  
JOHN WERNAU, KELLY BATES

DOC VERSION No: 4.0

ISSUE DATE: June 1, 2023

SHEET TITLE

ZONE PDU POWER DISTRIBUTION  
IN A HEALTH CARE FACILITY  
ENTRANCE ROOM

SHEET: 25 OF 57

NOTE: ALL GROUNDING SHALL BE DONE IN ACCORDANCE WITH ANSI/TIA -607-D "COMMERCIAL BUILDING GROUNDING (EARTHING) AND BONDING REQUIREMENTS FOR TELECOMMUNICATIONS", NFPA 70, AND IN COMPLIANCE WITH LOCAL CODES.

ALL EQUIPMENT SHALL BE GROUNDED PER MANUFACTURER'S INSTRUCTIONS.

NETWORK EQUIPMENT MUST BE GROUNDED. NEVER DEFEAT THE GROUND CONDUCTOR OR OPERATE THE EQUIPMENT IN THE ABSENCE OF A SUITABLY INSTALLED GROUND CONDUCTOR. THESE DEVICES WILL BE BONDED TO THE RACK BONDING BUSBAR (RBB) IN THE SAME RACK. EACH DEVICE WILL HAVE A DEDICATED UNIT BONDING CONDUCTOR (UBC). THE UBC WILL NOT BE SHARED.

CISCO 6509

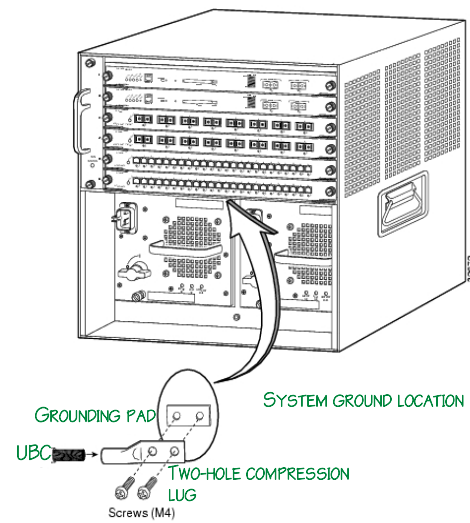

CISCO 9606

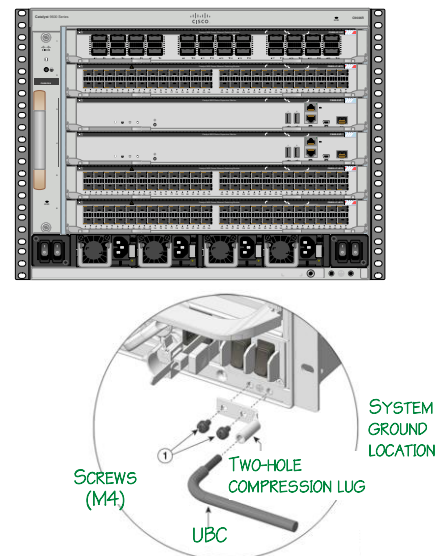

CISCO NEXUS 9510B/95180

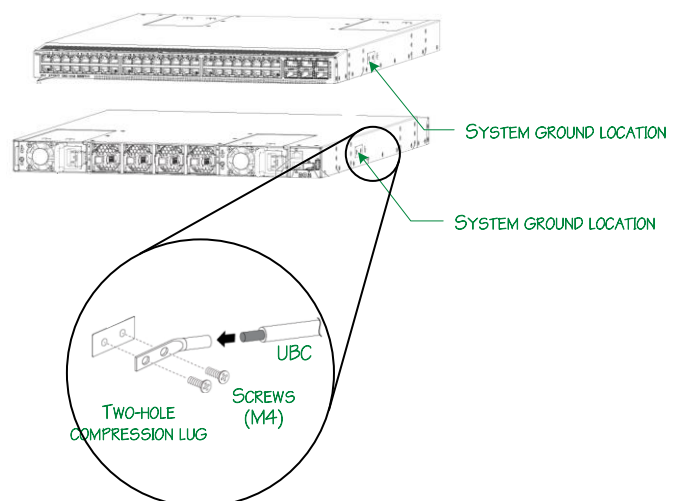

CISCO NEXUS 950B

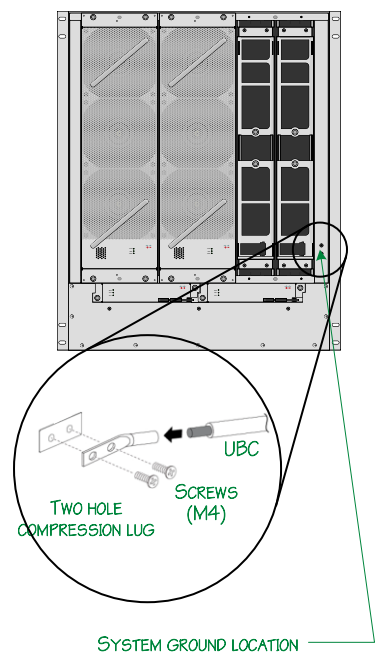

PER MANUFACTURER'S INSTRUCTIONS, WHEN ATTACHING A GROUNDING CABLE TO THE CHASSIS, YOU WILL NEED TO BEND ONE OF THE RACK-MOUNT RAILS SLIGHTLY TO ALLOW THE GROUNDING LUG TO GO BEHIND THE RAIL. ONLY ONE SIDE OF THE CHASSIS NEEDS TO BE BONDED.

2 EARTHING EXAMPLES  
REF: CISCO PRODUCT INSTALLATION GUIDE

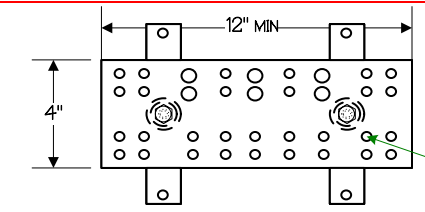

ANSI/EIA/TIA COMPLIANT BUSBAR  
CHATSWORTH P/N: 40158-012

3 TELECOMMUNICATIONS SECONDARY BONDING BUSBAR (SBB)

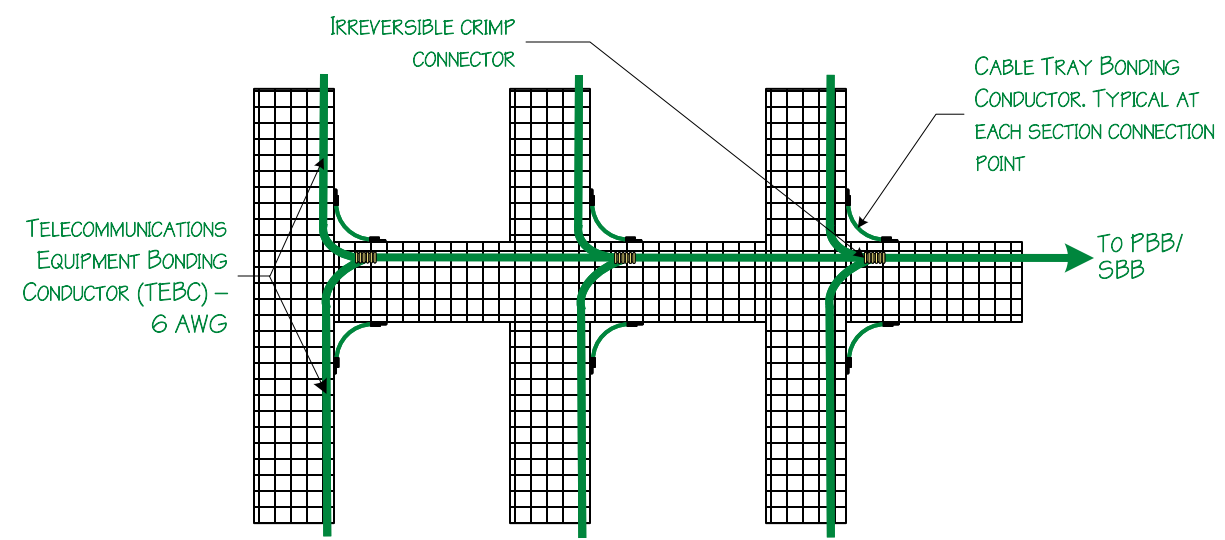
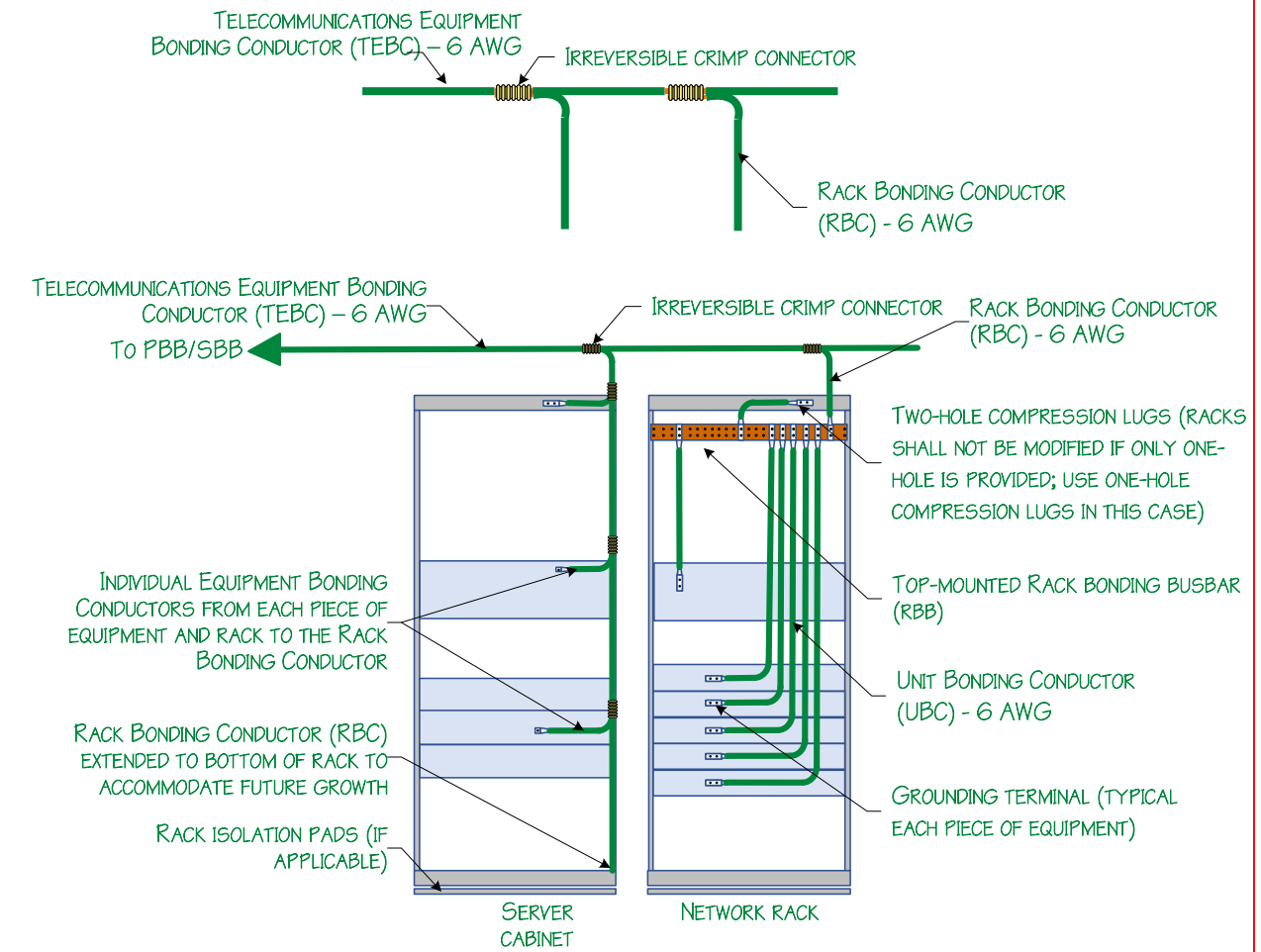

1 PATHWAY, RACK, BONDING CONDUCTOR JOIN REQUIREMENTS



PROJECT:

OIT DESIGN GUIDE TEMPLATES

PROJECT No:

N/A

MARK	DATE	DESCRIPTION

ISSUE:

DRAWING No:

FILE: OIT\_Design\_Guide\_Templates-V4 - TD.VSDX

DESIGN BY: KEVIN GRZELKA, CTDC

VERIFIED BY: MICHAEL JULIAN, RCDD  
JOHN WERNAU, KELLY BATES

DOC VERSION No: 4.0

ISSUE DATE: June 1, 2023

SHEET TITLE

BONDING

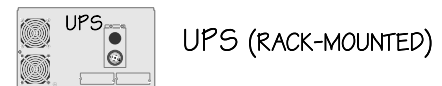
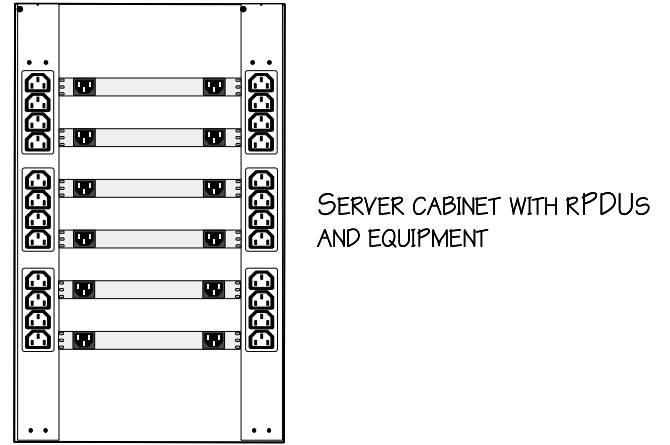
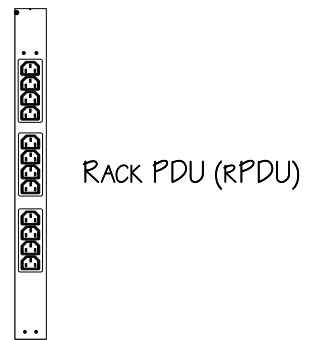
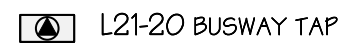
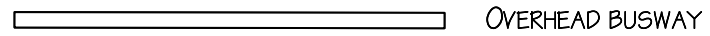
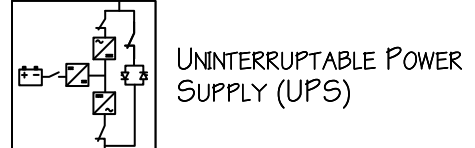
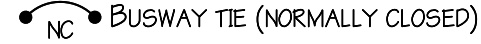

1 LEGEND FOR ELECTRICAL ONE-LINE DRAWINGS



PROJECT:

OIT DESIGN GUIDE TEMPLATES

PROJECT No:

N/A

MARK	DATE	DESCRIPTION

ISSUE:

DRAWING No:	
FILE:	OIT_Design_Guide_Templates-V4 - TD.VSDX
DESIGN BY:	KEVIN GRZELKA, CTDC
VERIFIED BY:	MICHAEL JULIAN, RCDD JOHN WERNAU, KELLY BATES
DOC VERSION No:	4.0
ISSUE DATE:	June 1, 2023

SHEET TITLE

LEGEND FOR ELECTRICAL ONE-LINE DRAWINGS

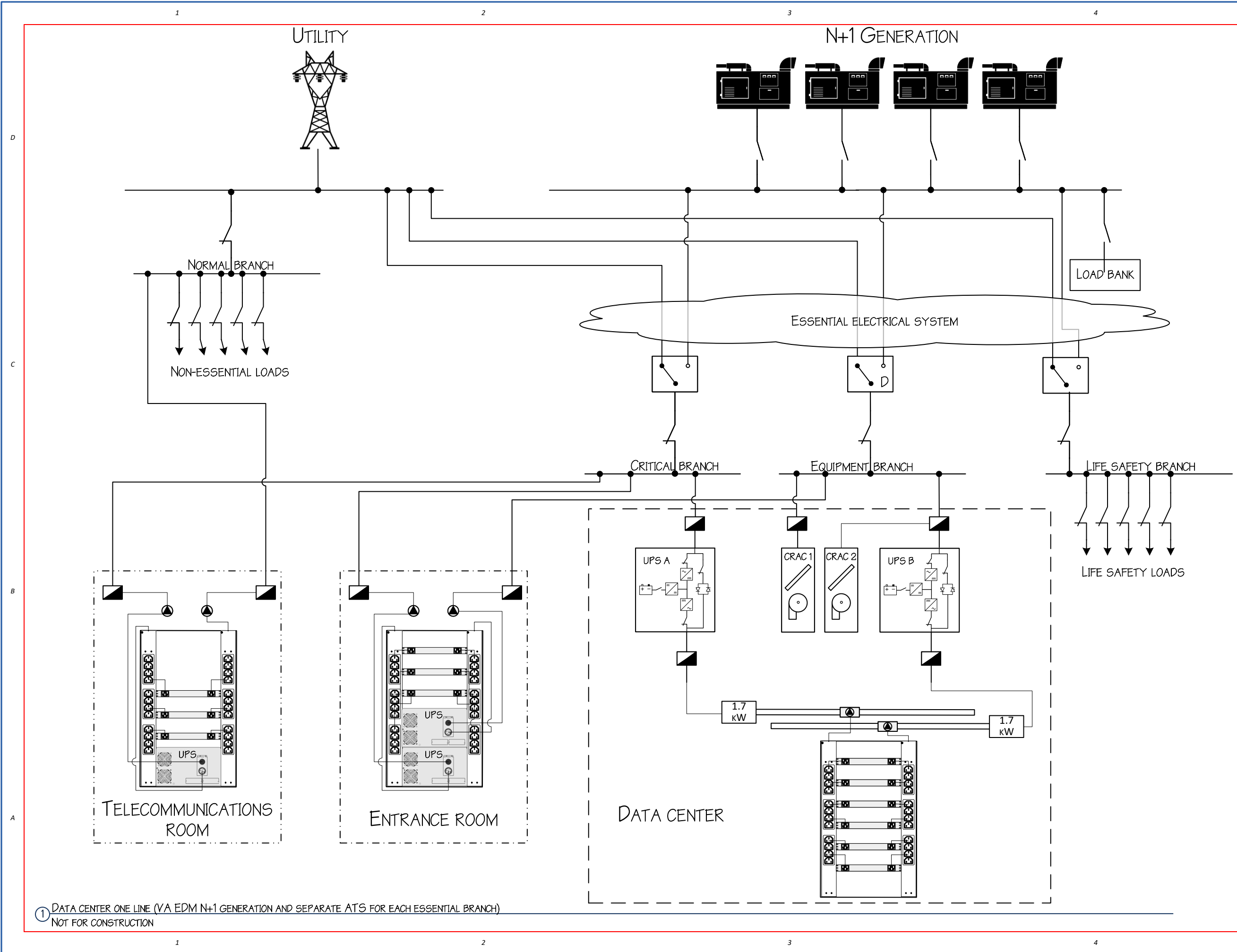

① DATA CENTER ONE LINE (VA EDM N+1 GENERATION AND SEPARATE ATS FOR EACH ESSENTIAL BRANCH)  
 NOT FOR CONSTRUCTION

DEPARTMENT OF VETERANS AFFAIRS

OFFICE OF INFORMATION AND TECHNOLOGY

INFRASTRUCTURE OPERATIONS - APPLICATION HOSTING, CLOUD AND EDGE SOLUTIONS

ENTERPRISE DATA CENTER AND INFRASTRUCTURE ENGINEERING

**EDCT**  
 ENTERPRISE DATA CENTER INFRASTRUCTURE COLLABORATION TEAM

**PROJECT:**  
 OIT DESIGN GUIDE TEMPLATES

**PROJECT No:**  
 N/A

MARK	DATE	DESCRIPTION

**ISSUE:**

**DRAWING No:**  
 FILE: OIT\_DESIGN\_GUIDE\_TEMPLATES-V4 - TD.VSDX

**DESIGN BY:** KEVIN GRZELKA, CTDC

**VERIFIED BY:** MICHAEL JULIAN, RCDD  
 JOHN WERNAU, KELLY BATES

**DOC VERSION No:** 4.0

**ISSUE DATE:** June 1, 2023

**SHEET TITLE**

**ELECTRICAL ONE-LINE (MINIMUM VA REQUIREMENT)**

**SHEET: 28 OF 57**

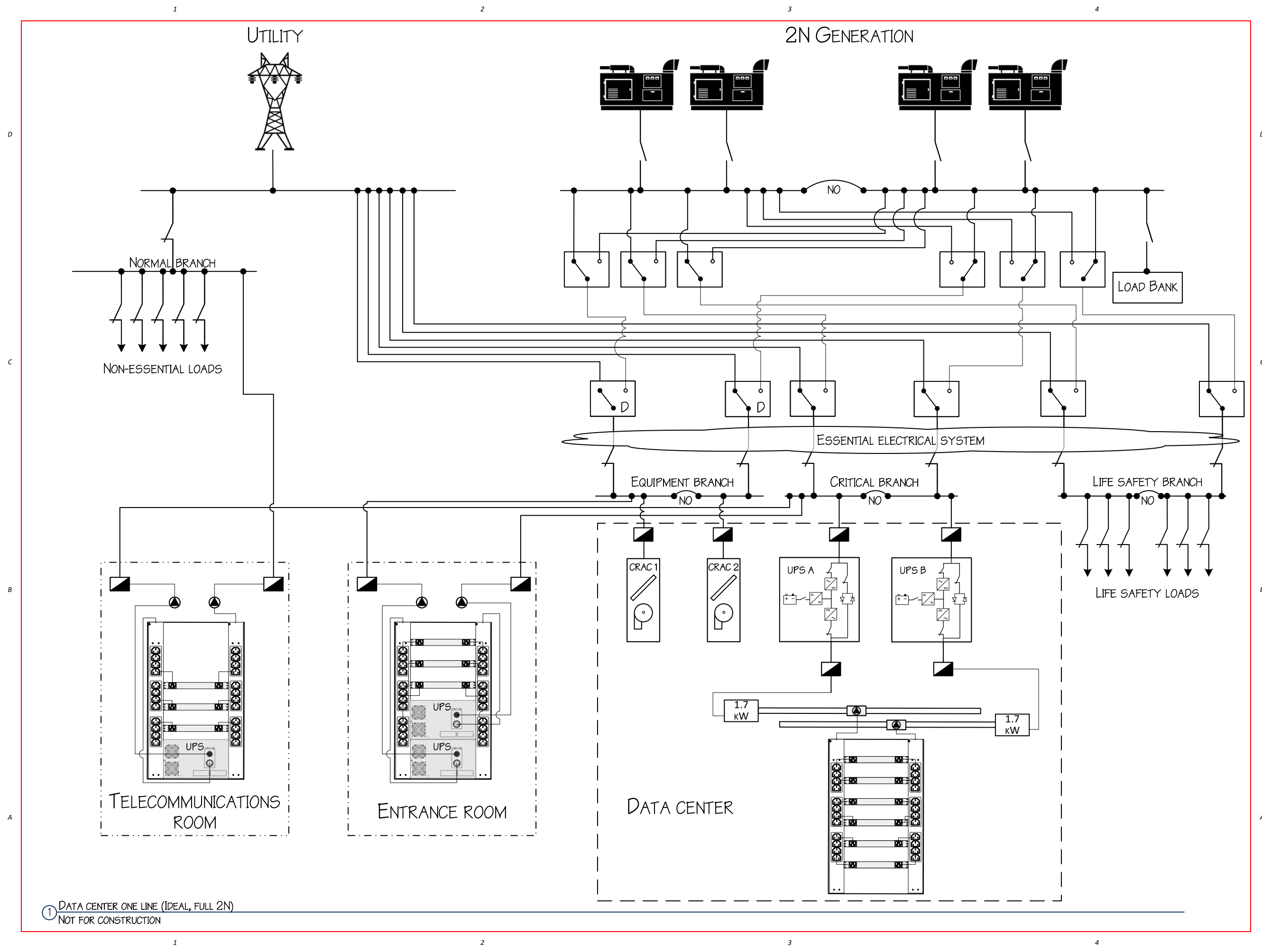

DEPARTMENT OF VETERANS AFFAIRS



OFFICE OF INFORMATION AND TECHNOLOGY

INFRASTRUCTURE OPERATIONS - APPLICATION HOSTING, CLOUD AND EDGE SOLUTIONS



ENTERPRISE DATA CENTER AND INFRASTRUCTURE ENGINEERING

**EDCT**

ENTERPRISE DATA CENTER INFRASTRUCTURE COLLABORATION TEAM

PROJECT:

OIT DESIGN GUIDE TEMPLATES

PROJECT No: N/A

MARK	DATE	DESCRIPTION

ISSUE:

DRAWING No:

FILE: OIT\_Design\_Guide\_Templates-V4 - TD.VSDX

DESIGN BY: KEVIN GRZELKA, CTDC

VERIFIED BY: MICHAEL JULIAN, RCDD; JOHN WERNAU, KELLY BATES

DOC VERSION No: 4.0

ISSUE DATE: June 1, 2023

SHEET TITLE

ELECTRICAL ONE-LINE (IDEAL REDUNDANCY)

SHEET: 29 OF 57

① DATA CENTER ONE LINE (IDEAL, FULL 2N)  
NOT FOR CONSTRUCTION

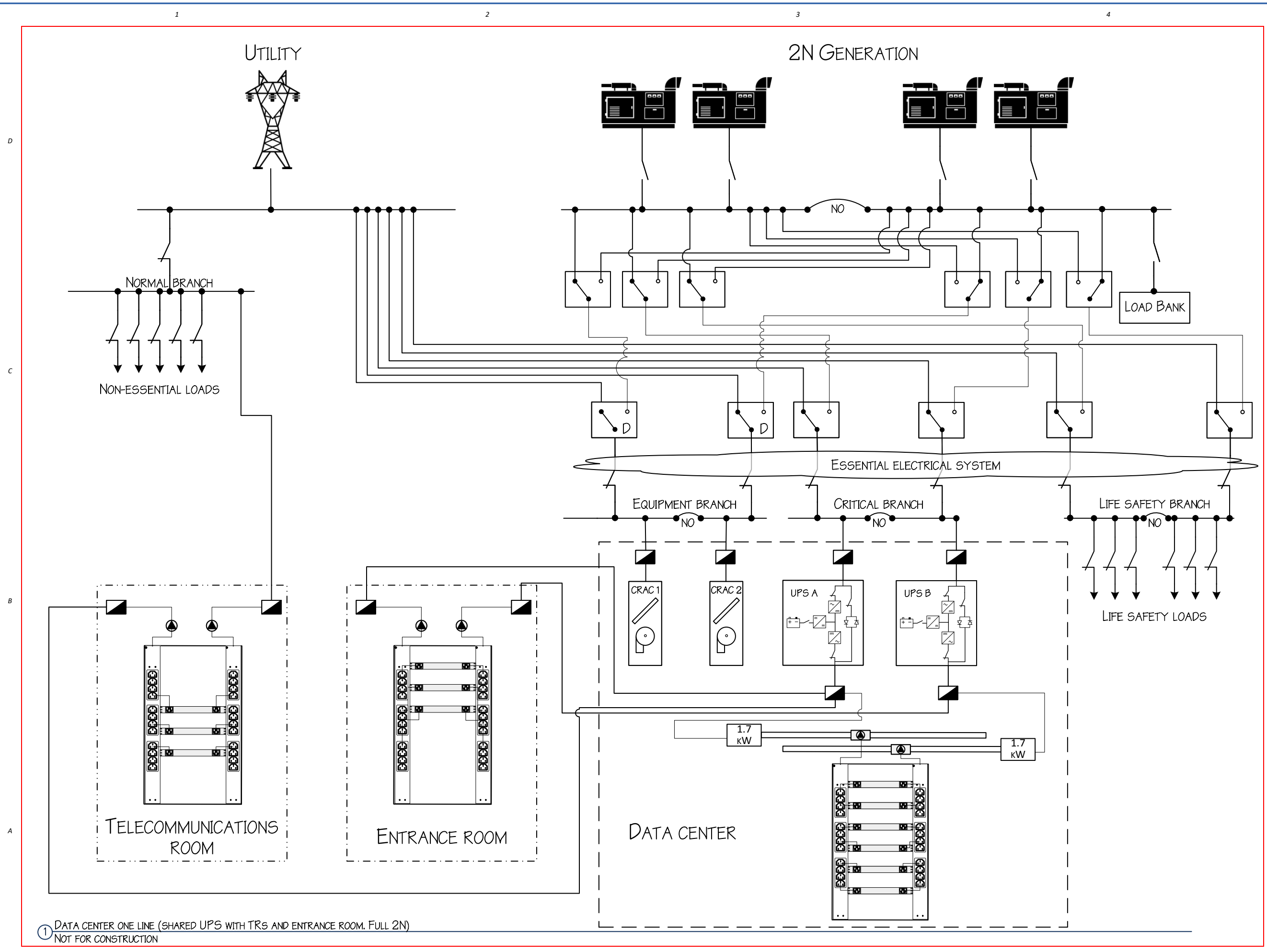

① DATA CENTER ONE LINE (SHARED UPS WITH TRS AND ENTRANCE ROOM. FULL 2N)  
NOT FOR CONSTRUCTION

DEPARTMENT OF VETERANS AFFAIRS

OFFICE OF INFORMATION AND TECHNOLOGY

INFRASTRUCTURE OPERATIONS - APPLICATION HOSTING, CLOUD AND EDGE SOLUTIONS

ENTERPRISE DATA CENTER AND INFRASTRUCTURE ENGINEERING

**EDCT**  
ENTERPRISE DATA CENTER INFRASTRUCTURE COLLABORATION TEAM

PROJECT:  
OIT DESIGN GUIDE TEMPLATES

PROJECT No:  
N/A

MARK	DATE	DESCRIPTION

ISSUE:

DRAWING No:  
FILE: OIT\_Design\_Guide\_Templates-V4 - TD.VSDX

DESIGN BY: KEVIN GRZELKA, CTDC

VERIFIED BY: MICHAEL JULIAN, RCDD  
JOHN WERNAU, KELLY BATES

DOC VERSION No: 4.0

ISSUE DATE: June 1, 2023

SHEET TITLE

**ELECTRICAL ONE-LINE (SHARED UPS)**

SHEET: 30 OF 57

1

2

3

4

D

C

B

A

# TELECOMMUNICATIONS DISTRIBUTION (ELEVATIONS, CABLING, AND ROUTING)

1

2

3

4

DEPARTMENT OF VETERANS AFFAIRS



OFFICE OF INFORMATION AND TECHNOLOGY

INFRASTRUCTURE OPERATIONS - APPLICATION HOSTING, CLOUD AND EDGE SOLUTIONS



ENTERPRISE DATA CENTER AND INFRASTRUCTURE ENGINEERING

EDCT

ENTERPRISE DATA CENTER INFRASTRUCTURE COLLABORATION TEAM

PROJECT:

OIT DESIGN GUIDE TEMPLATES

PROJECT No:

N/A

MARK	DATE	DESCRIPTION
------	------	-------------

ISSUE:

DRAWING No:

FILE: OIT\_DESIGN\_GUIDE\_TEMPLATES-V4 - TD.VSDX

DESIGN BY: KEVIN GRZELKA, CTDC

VERIFIED BY: MICHAEL JULIAN, RCDD  
JOHN WERNAU, KELLY BATES

DOC VERSION No: 4.0

ISSUE DATE: June 1, 2023

SHEET TITLE

TELECOMMUNICATIONS DISTRIBUTION (ELEVATIONS, CABLING, AND ROUTING)

SHEET: 31 OF 57

DATA CENTER SERVER CABINETS (REAR TOP 5 RU OF EACH CABINET)

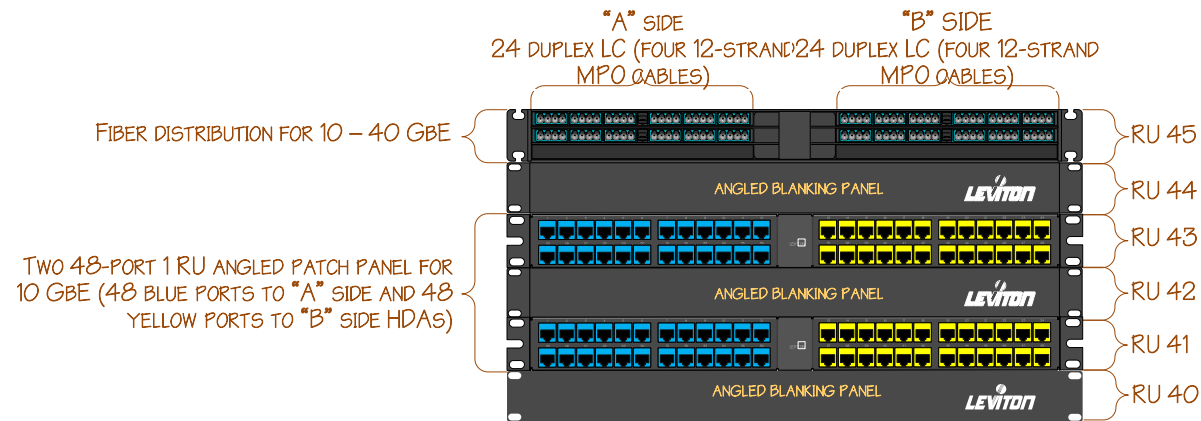

QUANTITIES OF HD EQUIPMENT DISTRIBUTORS AND FIBER AND UTP AMOUNT PER SITE REQUIREMENTS

3 HIGH DENSITY EQUIPMENT DISTRIBUTOR ELEVATION FOR CABINETS

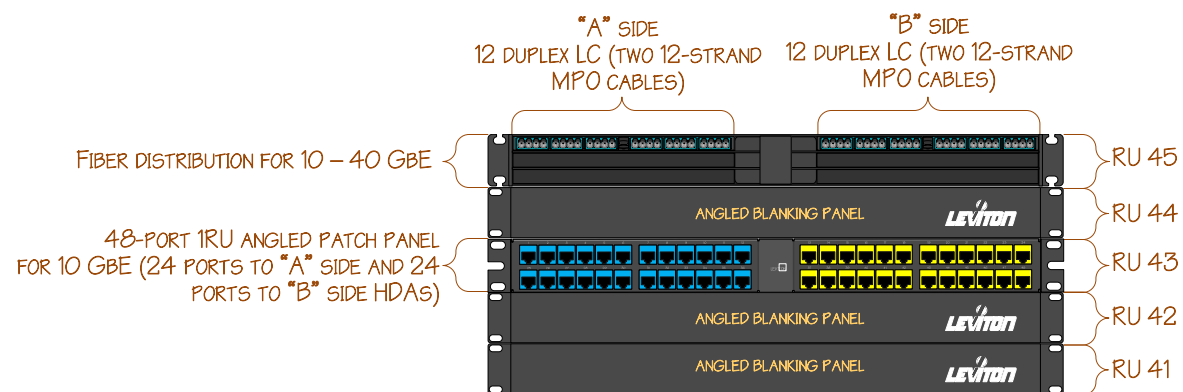

QUANTITIES OF FIBER AND UTP ARE MINIMUM AMOUNT; ACTUAL QUANTITIES PER SITE REQUIREMENTS

2 STANDARD DENSITY EQUIPMENT DISTRIBUTOR ELEVATION FOR CABINETS

DATA CENTER NETWORK CABINETS (END OF EACH ROW: A-SIDE ONE END, B-SIDE ON THE OTHER END)

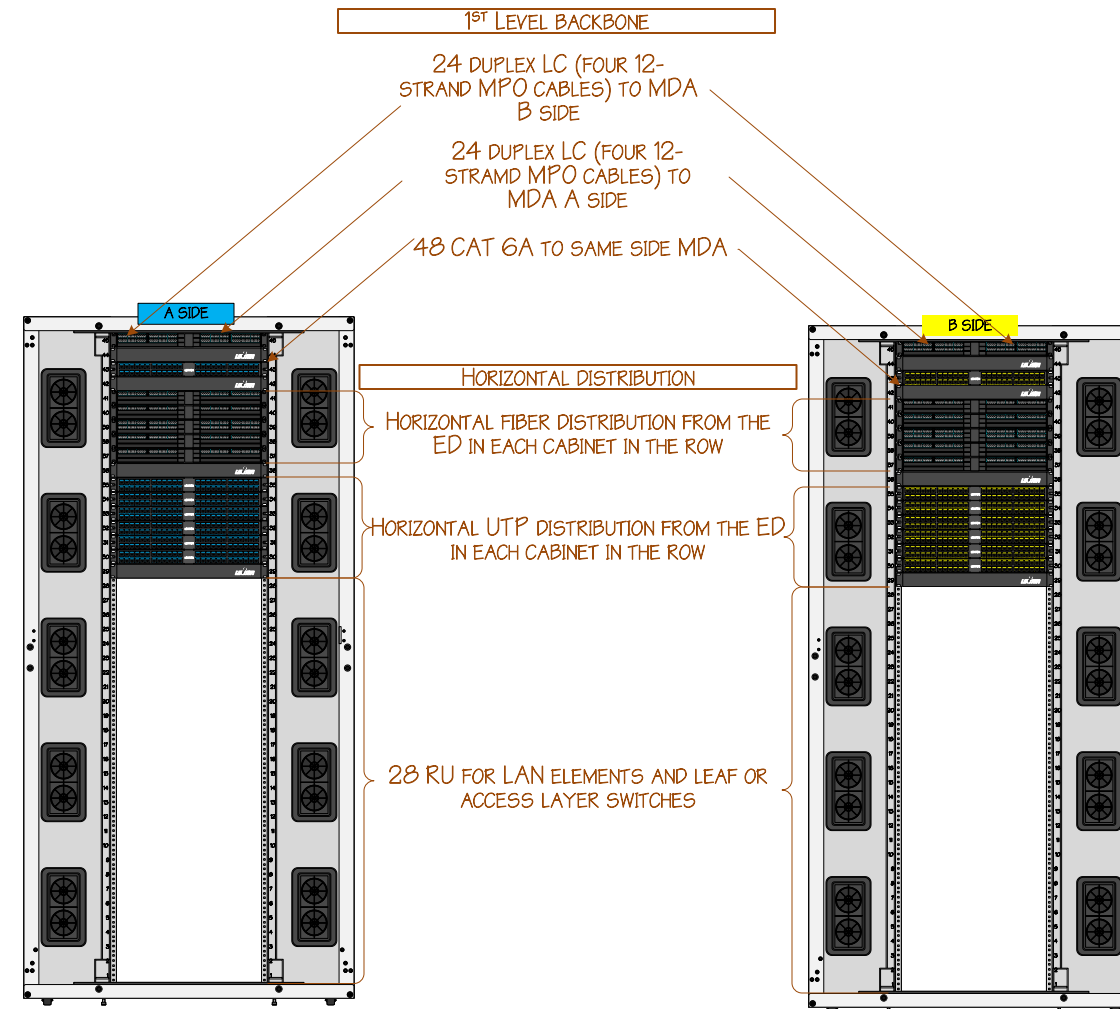

1 TYPICAL END OF ROW HORIZONTAL DISTRIBUTION AREA



PROJECT:

OIT DESIGN GUIDE TEMPLATES

PROJECT No:

N/A

MARK	DATE	DESCRIPTION

ISSUE:

DRAWING No:

FILE: OIT\_Design\_Guide\_Templates-V4 - TD.VSDX

DESIGN BY: KEVIN GRZELKA, CTDC

VERIFIED BY: MICHAEL JULIAN, RCDD  
JOHN WERNAU, KELLY BATES

DOC VERSION No: 4.0

ISSUE DATE: June 1, 2023

SHEET TITLE

ED & HD (L, M, S)



NETWORK CABINETS CREATING ONE ROW IN THE DATA CENTER ESTABLISHING THE MAIN DISTRIBUTION AREA

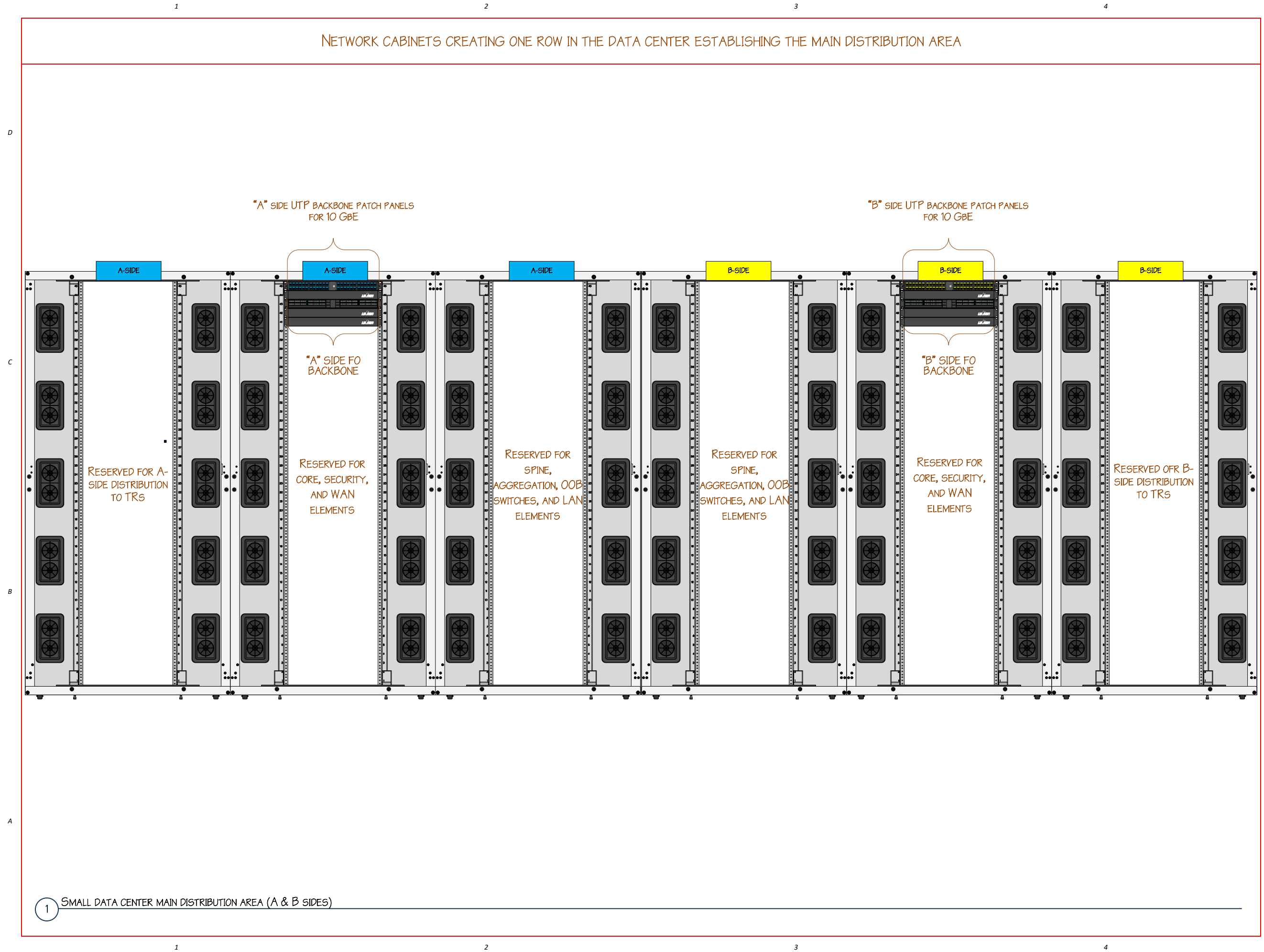

1 SMALL DATA CENTER MAIN DISTRIBUTION AREA (A & B SIDES)



PROJECT:

OIT DESIGN GUIDE TEMPLATES

PROJECT No: N/A

MARK	DATE	DESCRIPTION
------	------	-------------

ISSUE:

DRAWING No:  
 FILE: OIT\_Design\_Guide\_Templates-V4 - TD.VSDX  
 DESIGN BY: KEVIN GRZELKA, CTDC  
 VERIFIED BY: MICHAEL JULIAN, RCDD  
 JOHN WERNAU, KELLY BATES  
 DOC VERSION No: 4.0  
 ISSUE DATE: June 1, 2023

SHEET TITLE

MDA (S)

DATA CENTER DIVERSE PATH DISTRIBUTION

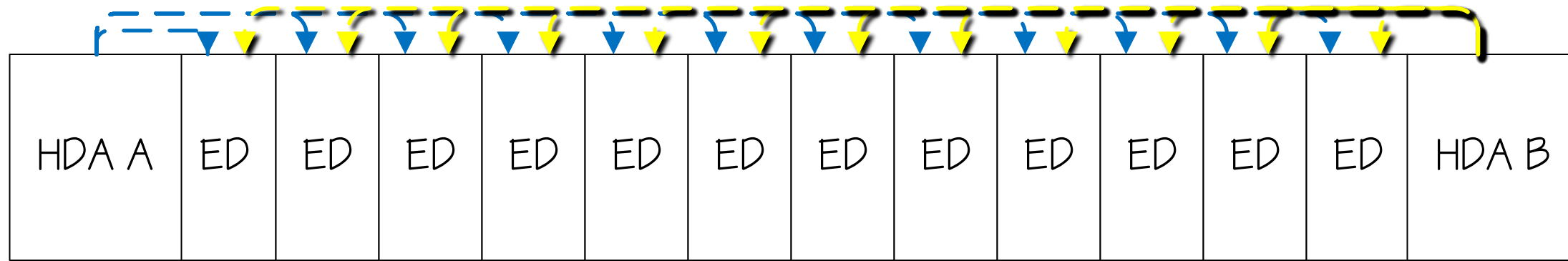

--- ▶ (2) MPO-12 TO MPO-12 OM4 TRUNK CABLES [(4) MPO-12/DUPLEX LC CASSETTES]/24 CAT 6A – A-SIDE  
--- ▶ (2) MPO-12 TO MPO-12 OM4 TRUNK CABLES [(4) MPO-12/DUPLEX LC CASSETTES]/24 CAT 6A – B-SIDE

② DIVERSE ROUTING CABINETS (EQUIPMENT DISTRIBUTOR) TO HORIZONTAL DISTRIBUTION AREA

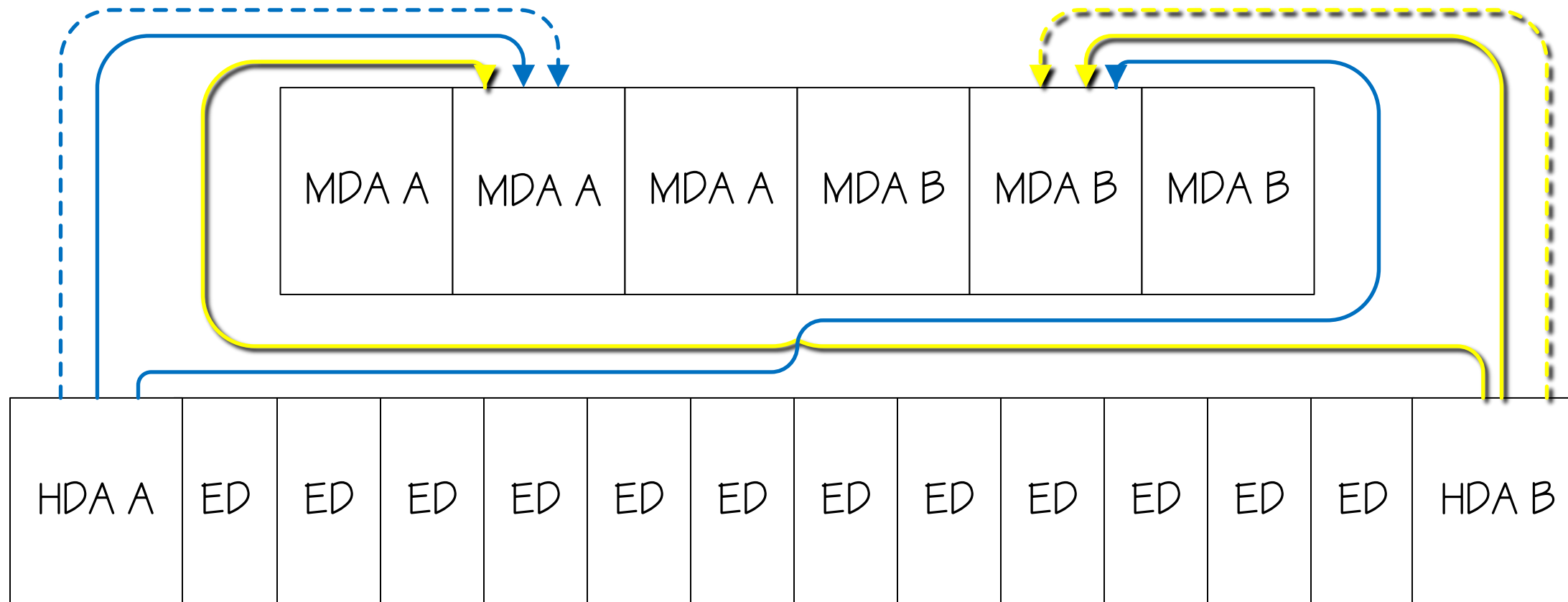

——▶ (4) MPO-12 TO MPO-12 OM4 TRUNK CABLES [(8) MPO-12/DUPLEX LC CASSETTES] – A-SIDE  
——▶ (4) MPO-12 TO MPO-12 OM4 TRUNK CABLES [(8) MPO-12/DUPLEX LC CASSETTES] – B-SIDE  
---▶ 48 CAT 6A – A-SIDE  
---▶ 48 CAT 6A – B-SIDE

① DIVERSE ROUTING HORIZONTAL DISTRIBUTION AREA TO MAIN DISTRIBUTION AREA



PROJECT:

OIT DESIGN GUIDE TEMPLATES

PROJECT No:

N/A

MARK	DATE	DESCRIPTION

ISSUE:

DRAWING No:

FILE: OIT\_Design\_Guide\_Templates-V4 - TD.VSDX

DESIGN BY: KEVIN GRZELKA, CTDC

VERIFIED BY: MICHAEL JULIAN, RCDD  
JOHN WERNAU, KELLY BATES

DOC VERSION No: 4.0

ISSUE DATE: June 1, 2023

SHEET TITLE

SMALL DATA CENTER (MCR) NETWORK DIVERSITY

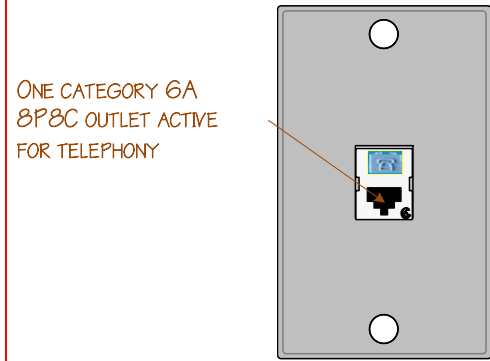

4 TYPICAL WALL MOUNT PHONE VOIP OUTLET

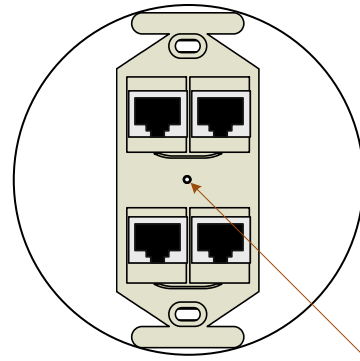

5 TYPICAL WORK FLOOR MOUNT OUTLET

Note:

TYPICAL WORK AREA OUTLET FACEPLATE WILL BE INSTALLED WITH CATEGORY 6A COMPONENT-COMPLIANT 8P8C MEDIA INTERFACE CONNECTORS (RJ45). EACH CONNECTOR WILL BE TERMINATED TO HIGH QUALITY CATEGORY 6A HORIZONTAL CABLING WHICH WILL TERMINATE IN THE TELECOMMUNICATIONS ROOM AS SPECIFIED ELSEWHERE IN THIS DESIGN PACKAGE.  
ALL HORIZONTAL UTP SHALL BE CATEGORY 6A AND TERMINATED TO T568B.

TYPICAL FACEPLATE WILL BE INSTALLED WITH TWO RJ45S. HIGH DENSITY FACEPLATES WILL BE INSTALLED WITH FOUR RJ45S.

FACEPLATE MATERIAL AND COLOR DETERMINED BY OTHERS.

ALL LABELING SHALL BE ANSI/TIA-606-D COMPLIANT AS MODIFIED FOR SOME ELEMENTS IN SECTION 5 OF THE ISTS. MACHINE PRINTED. FURTHER GUIDANCE ON ADMINISTRATION MAY BE SPECIFIED IN OTHER SECTIONS OF THIS DESIGN PACKAGE.

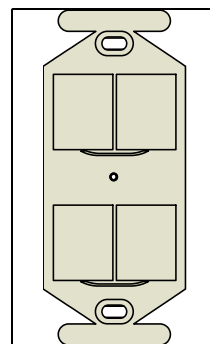

SINGLE GANG WORKBOX WITH TWO CONNECTOR CHASSIS

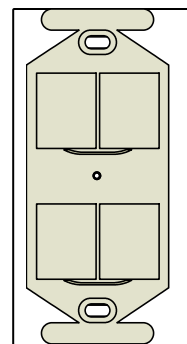

SINGLE GANG WORKBOX WITH ONE CONNECTOR CHASSIS

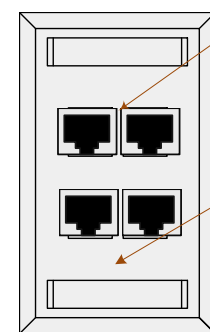

3 TYPICAL HIGH DENSITY WALL MOUNTED WORK AREA OUTLET CONFIGURATION

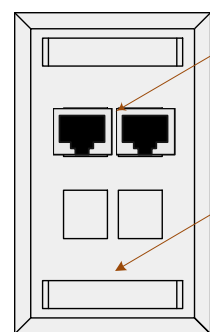

2 STANDARD DENSITY WALL MOUNTED WORK AREA OUTLET CONFIGURATION

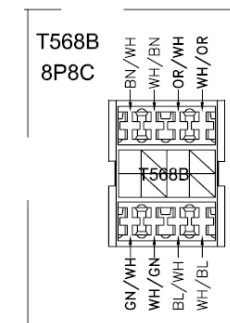

1 ANSI/TIA T568B 8P8C WIRING STANDARD



PROJECT:

OIT DESIGN GUIDE TEMPLATES

PROJECT No:

N/A

MARK	DATE	DESCRIPTION

ISSUE:

DRAWING No:

FILE: OIT\_Design\_Guide\_Templates-V4 - TD.VSDX

DESIGN BY: KEVIN GRZELKA, CTDC

VERIFIED BY: MICHAEL JULIAN, RCDD  
JOHN WERNAU, KELLY BATES

DOC VERSION No: 4.0

ISSUE DATE: June 1, 2023

SHEET TITLE

WORK AREA OUTLETS

WHEN TRAVERSING ALONG THE SAME PATHWAY, DIVERSE ROUTED CONDUITS MAY SHARE THE SAME DUCT BANKS AND MAINTENANCE HOLE SYSTEM

--- A-SIDE PATHWAY  
 ——— B-SIDE PATHWAY

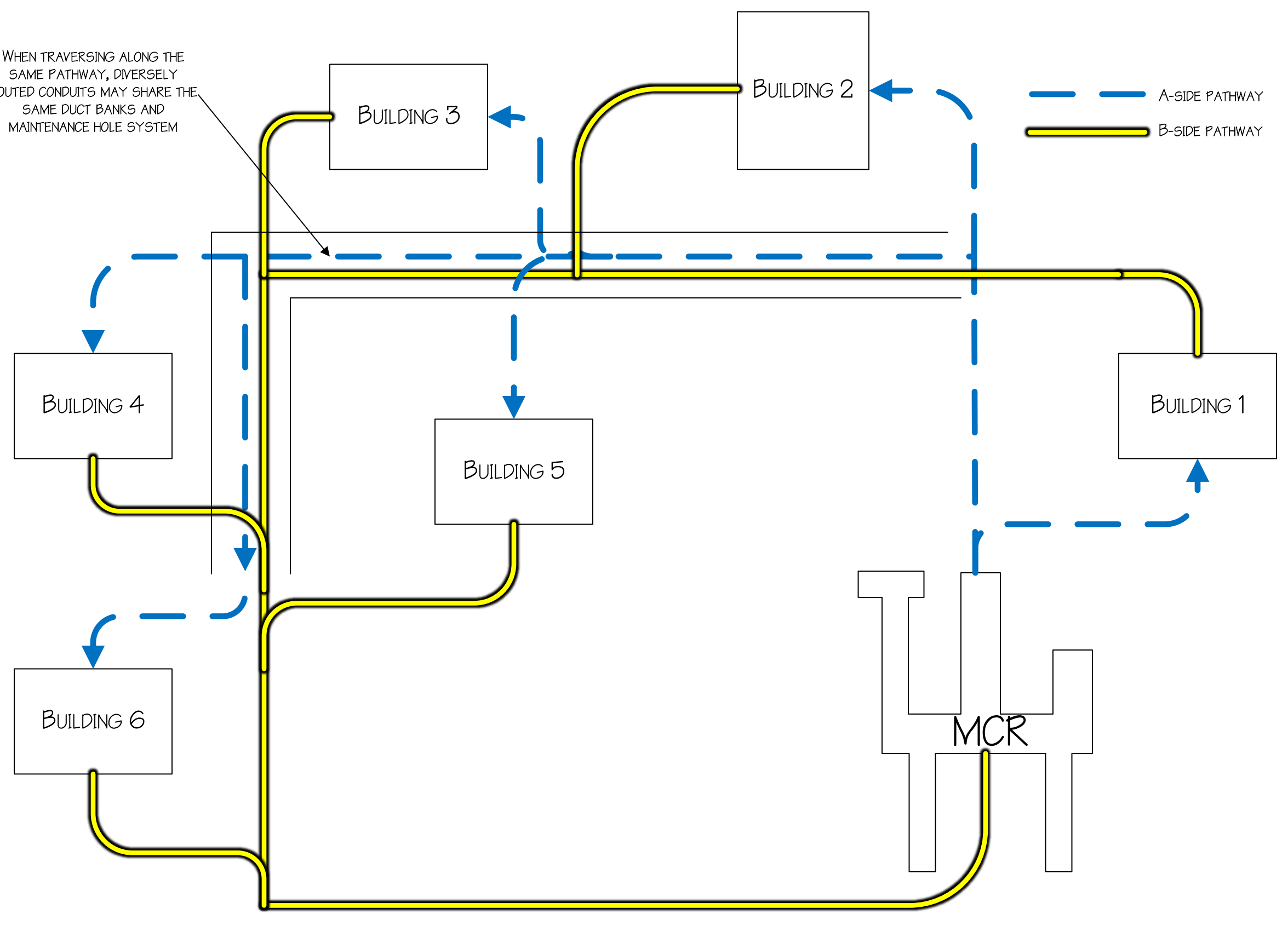

① SIMPLIFIED OUTSIDE PLANT DIVERSE TELECOMMUNICATIONS BACKBONE PATHWAYS

DEPARTMENT OF VETERANS AFFAIRS



OFFICE OF INFORMATION AND TECHNOLOGY

INFRASTRUCTURE OPERATIONS - APPLICATION HOSTING, CLOUD AND EDGE SOLUTIONS



ENTERPRISE DATA CENTER AND INFRASTRUCTURE ENGINEERING

**EDICT**

ENTERPRISE DATA CENTER INFRASTRUCTURE COLLABORATION TEAM

PROJECT:

OIT DESIGN GUIDE TEMPLATES

PROJECT No:

N/A

MARK	DATE	DESCRIPTION

ISSUE:

DRAWING No:

FILE: OIT\_Design\_Guide\_Templates-V4 - TD.VSDX

DESIGN BY: KEVIN GRZELKA, CTDC

VERIFIED BY: MICHAEL JULIAN, RCDD  
JOHN WERNAU, KELLY BATES

DOC VERSION No: 4.0

ISSUE DATE: June 1, 2023

SHEET TITLE

SIMPLIFIED OSP DIVERSE ROUTING

1

2

3

4

D

C

B

A

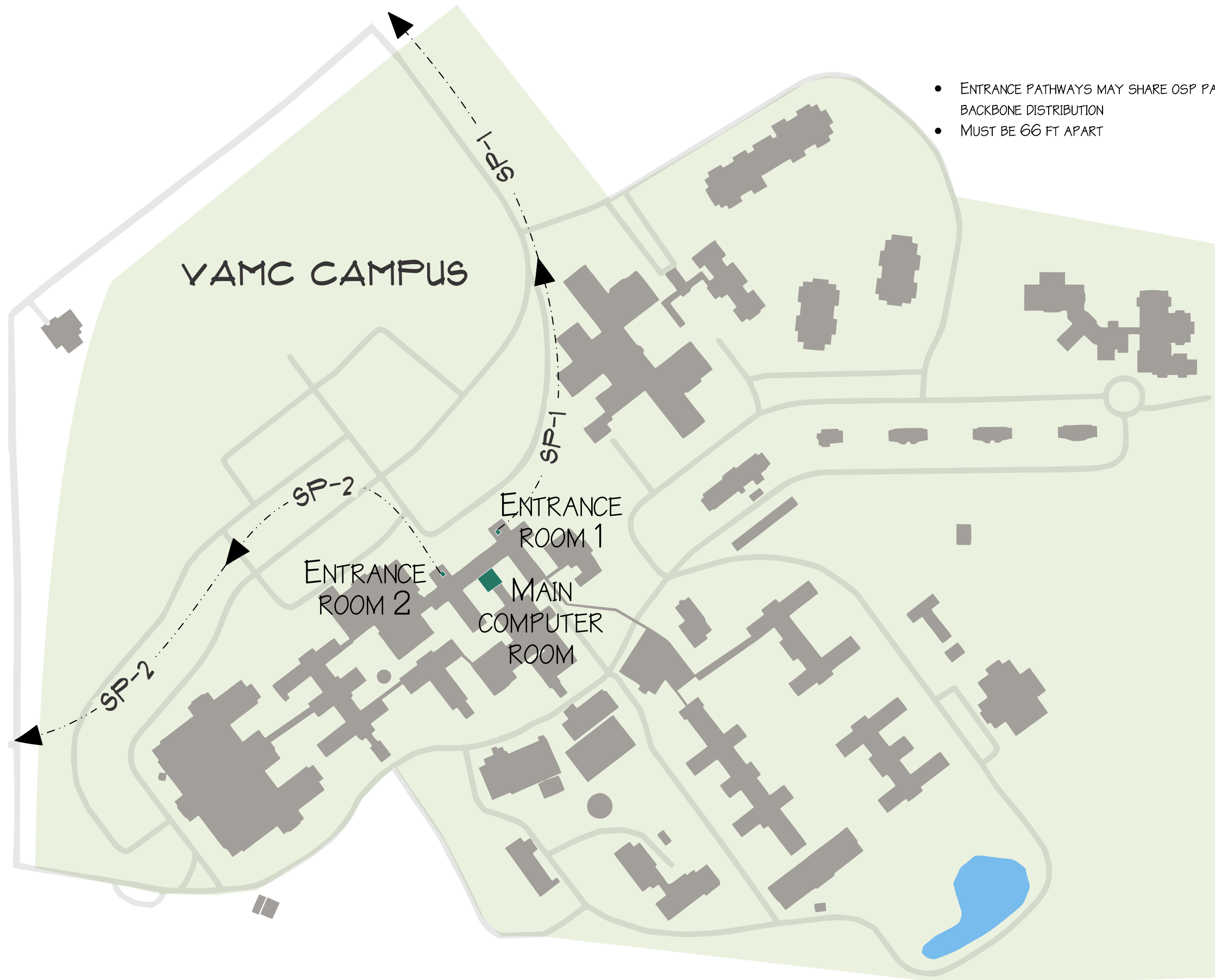

- ENTRANCE PATHWAYS MAY SHARE OSP PATHWAYS WITH BACKBONE DISTRIBUTION
- MUST BE 66 FT APART

① SAMPLE OUTSIDE PLANT TELECOMMUNICATIONS SERVICE PROVIDER ENTRANCE DIVERSE PATHWAYS

1

2

3

4

DEPARTMENT OF VETERANS AFFAIRS



OFFICE OF INFORMATION AND TECHNOLOGY

INFRASTRUCTURE OPERATIONS - APPLICATION HOSTING, CLOUD AND EDGE SOLUTIONS



ENTERPRISE DATA CENTER AND INFRASTRUCTURE ENGINEERING

**EDICT**

ENTERPRISE DATA CENTER INFRASTRUCTURE COLLABORATION TEAM

PROJECT:

OIT DESIGN GUIDE TEMPLATES

PROJECT No:

N/A

MARK	DATE	DESCRIPTION

ISSUE:

DRAWING No:

FILE: OIT\_DESIGN\_GUIDE\_TEMPLATES-V4 - TD.VSDX

DESIGN BY: KEVIN GRZELKA, CTDC

VERIFIED BY: MICHAEL JULIAN, RCDD  
JOHN WERNAU, KELLY BATES

DOC VERSION No: 4.0

ISSUE DATE: June 1, 2023

SHEET TITLE

SERVICE PROVIDER PATHWAY ROUTING EXAMPLE

1

2

3

4

D

C

B

A

# VAMC CAMPUS

## MAIN COMPUTER ROOM

- EACH BUILDING MUST HAVE TWO DISTINCT ENTRY POINTS, ONE FOR EACH PATH
- ENTRY 180° APART PREFERRED
- BI-DIRECTIONAL LOOP SHOWN
- OTHER OPTIONS (STAR) ARE POSSIBLE AS LONG AS PATHS MAINTAIN 50 FT SEPARATION

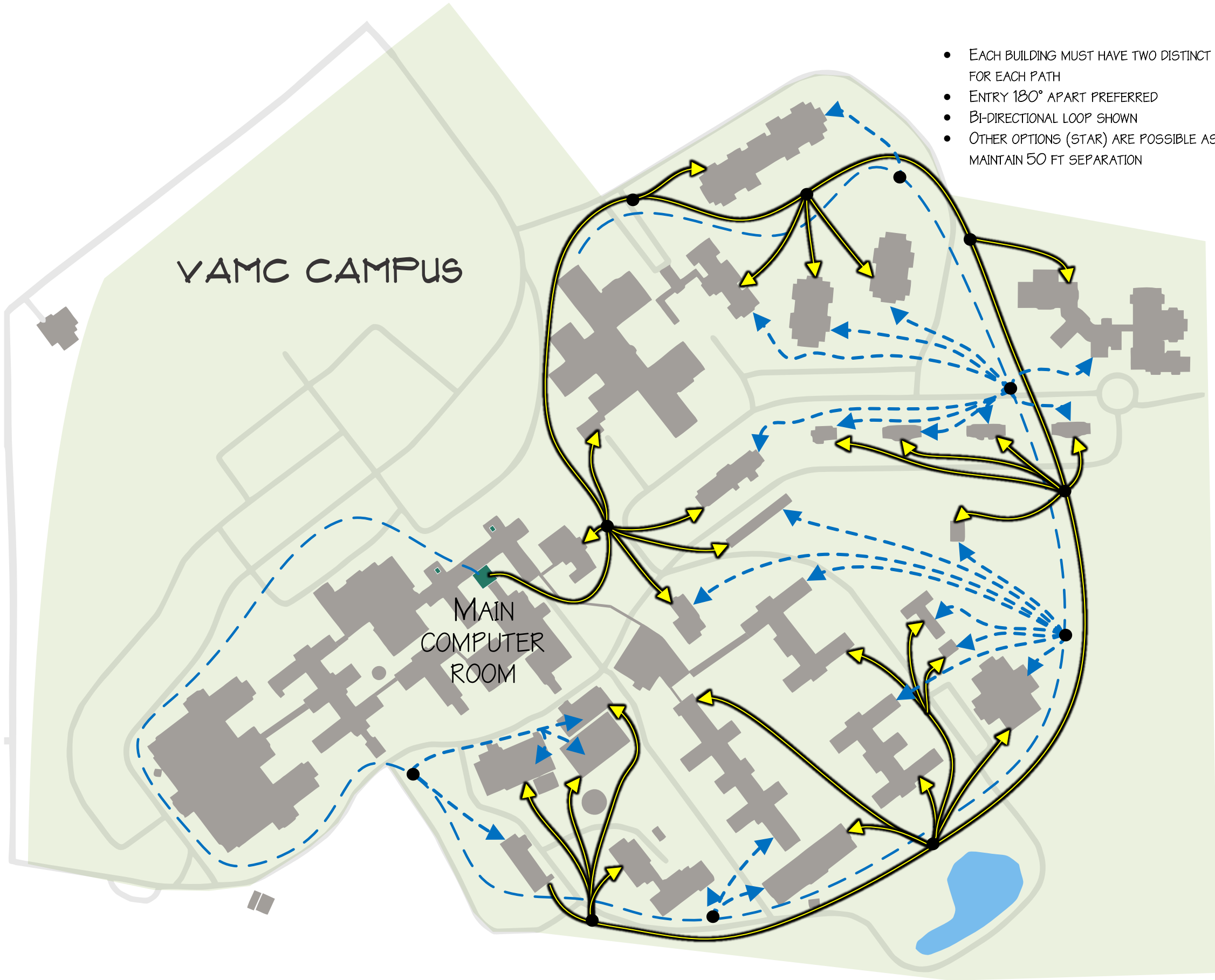

1 SAMPLE OUTSIDE PLANT CAMPUS TELECOMMUNICATIONS BACKBONE ROUTING - DIVERSE PATHWAYS

1

2

3

4

DEPARTMENT OF VETERANS AFFAIRS



OFFICE OF INFORMATION AND TECHNOLOGY

INFRASTRUCTURE OPERATIONS - APPLICATION HOSTING, CLOUD AND EDGE SOLUTIONS



ENTERPRISE DATA CENTER AND INFRASTRUCTURE ENGINEERING

**EDCT**  
ENTERPRISE DATA CENTER INFRASTRUCTURE COLLABORATION TEAM

PROJECT:  
OIT DESIGN GUIDE TEMPLATES

PROJECT No:  
N/A

MARK	DATE	DESCRIPTION

ISSUE:

DRAWING No:  
FILE: OIT\_DESIGN\_GUIDE\_TEMPLATES-V4 - TD.VSDX

DESIGN BY: KEVIN GRZELKA, CTDC

VERIFIED BY: MICHAEL JULIAN, RCDD  
JOHN WERNAU, KELLY BATES

DOC VERSION No: 4.0

ISSUE DATE: June 1, 2023

SHEET TITLE

CAMPUS BACKBONE PATHWAY ROUTING EXAMPLE

SHEET: 38 OF 57

D

C

B

A

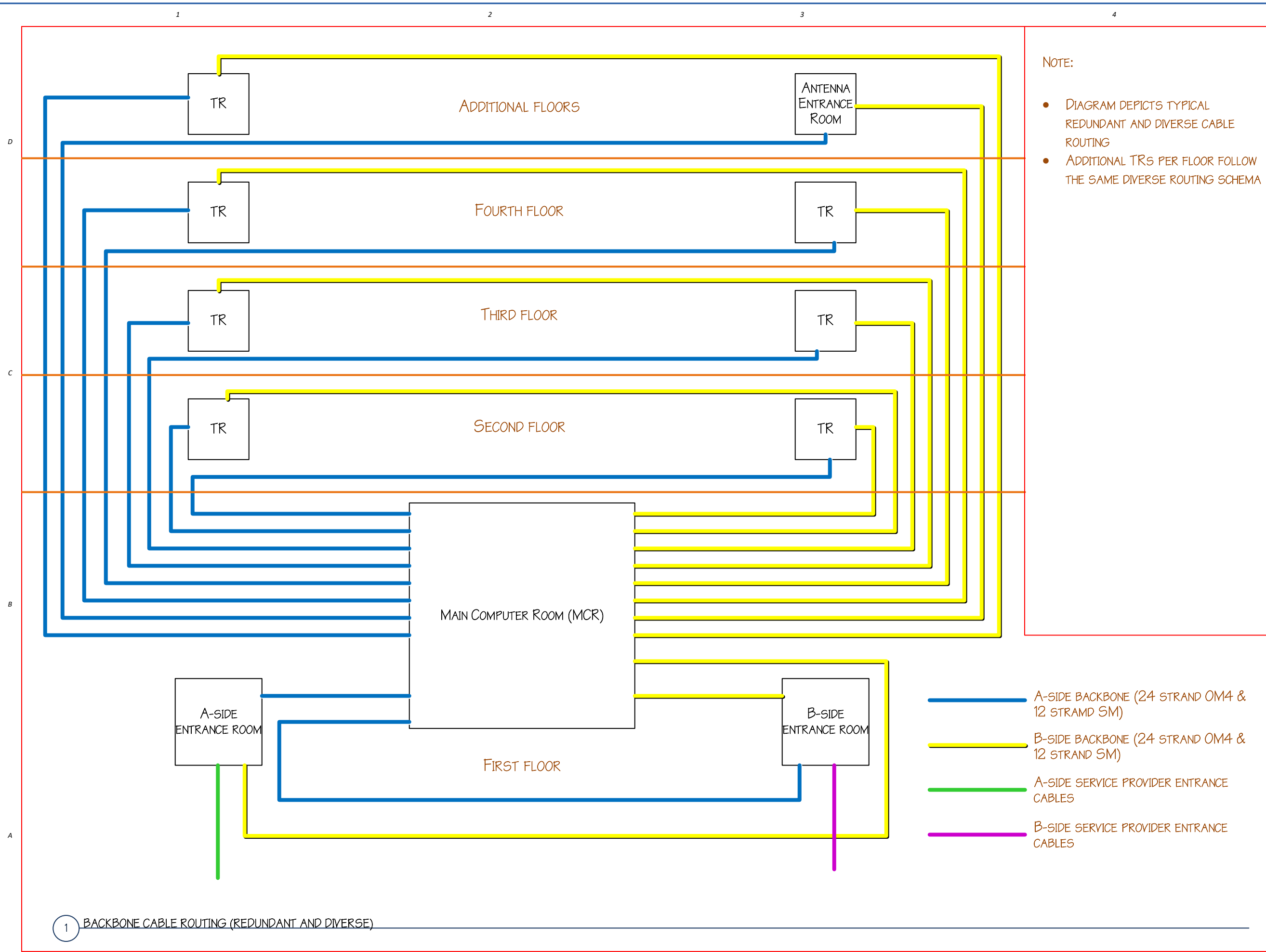

NOTE:

- DIAGRAM DEPICTS TYPICAL REDUNDANT AND DIVERSE CABLE ROUTING
- ADDITIONAL TRS PER FLOOR FOLLOW THE SAME DIVERSE ROUTING SCHEMA

- A-SIDE BACKBONE (24 STRAND OM4 & 12 STRAND SM)
- B-SIDE BACKBONE (24 STRAND OM4 & 12 STRAND SM)
- A-SIDE SERVICE PROVIDER ENTRANCE CABLES
- B-SIDE SERVICE PROVIDER ENTRANCE CABLES

1 BACKBONE CABLE ROUTING (REDUNDANT AND DIVERSE)

DEPARTMENT OF VETERANS AFFAIRS



OFFICE OF INFORMATION AND TECHNOLOGY

INFRASTRUCTURE OPERATIONS - APPLICATION HOSTING, CLOUD AND EDGE SOLUTIONS



ENTERPRISE DATA CENTER AND INFRASTRUCTURE ENGINEERING

**EDICT**  
ENTERPRISE DATA CENTER INFRASTRUCTURE COLLABORATION TEAM

**PROJECT:**  
OIT DESIGN GUIDE TEMPLATES

PROJECT No: N/A

MARK	DATE	DESCRIPTION

ISSUE:

DRAWING No:  
FILE: OIT\_Design\_Guide\_Templates-V4 - TD.VSDX

DESIGN BY: KEVIN GRZELKA, CTDC

VERIFIED BY: MICHAEL JULIAN, RCDD  
JOHN WERNAU, KELLY BATES

DOC VERSION No: 4.0

ISSUE DATE: June 1, 2023

SHEET TITLE

SIMPLIFIED INSIDE PLANT BACKBONE PATHWAY ROUTING

SHEET: 39 OF 57



SINCE ONLY A SINGLE PATHWAY EXISTS TO THE SW PORTION OF THE BUILDING CLUSTER, THE PATHWAYS FOR A AND B ROUTING WILL NEED TO MAINTAIN DIVERSITY BY ROUTING ON DIFFERENT FLOORS. (E.G. "A" PATHWAY ON FIRST FLOOR, "B" PATHWAY ON THIRD FLOOR. IF ONLY A SINGLE FLOOR INDOOR PATHWAY EXISTS, MINIMALLY SEPARATE PATHWAYS TO OPPOSITE SIDES OF THE HALLWAY)

B-PATHWAY THROUGH OUTSIDE PLANT ROUTING TO AVOID ROUTING ADJACENT TO THE "A" PATHWAY

① SAMPLE INSIDE PLANT DIVERSE TELECOMMUNICATIONS BACKBONE PATHWAYS



PROJECT:

OIT DESIGN GUIDE TEMPLATES

PROJECT No:

N/A

MARK	DATE	DESCRIPTION

ISSUE:

DRAWING No:

FILE: OIT\_DESIGN\_GUIDE\_TEMPLATES-V4 - TD.VSDX

DESIGN BY: KEVIN GRZELKA, CTDC

VERIFIED BY: MICHAEL JULIAN, RCDD  
JOHN WERNAU, KELLY BATES

DOC VERSION No: 4.0

ISSUE DATE: June 1, 2023

SHEET TITLE

INSIDE PLANT BACKBONE PATHWAY ROUTING EXAMPLE



RULE OF THIRDS FOR TR RACKS

- INDIVIDUAL RACK CAPACITIES REMAIN THE SAME REGARDLESS OF THE NUMBER OF RACKS IN THE TR
- HEALTHCARE TR SIZING REMAINS 170 FT<sup>2</sup> EXCEPT DURING REMODELS WHERE THE MINIMUM IS 100 FT<sup>2</sup>

TR SIZING (NON-HEALTHCARE)		
1 RACK	1-144 WAOS	80 FT <sup>2</sup>
2 RACKS	145-240 WAOS	100 FT <sup>2</sup>
3 RACKS	241-480 WAOS	120 FT <sup>2</sup>
4 RACKS	>480 WAOS	140 FT <sup>2</sup>

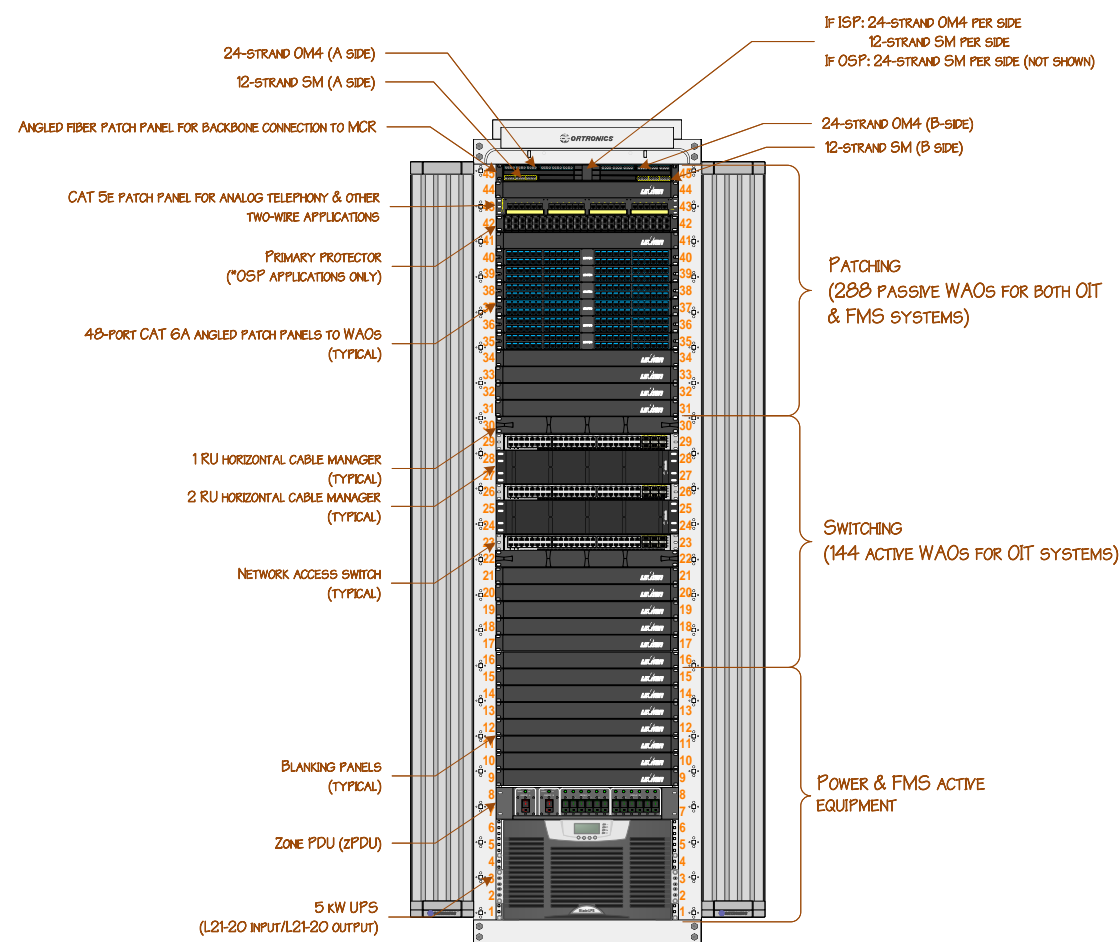
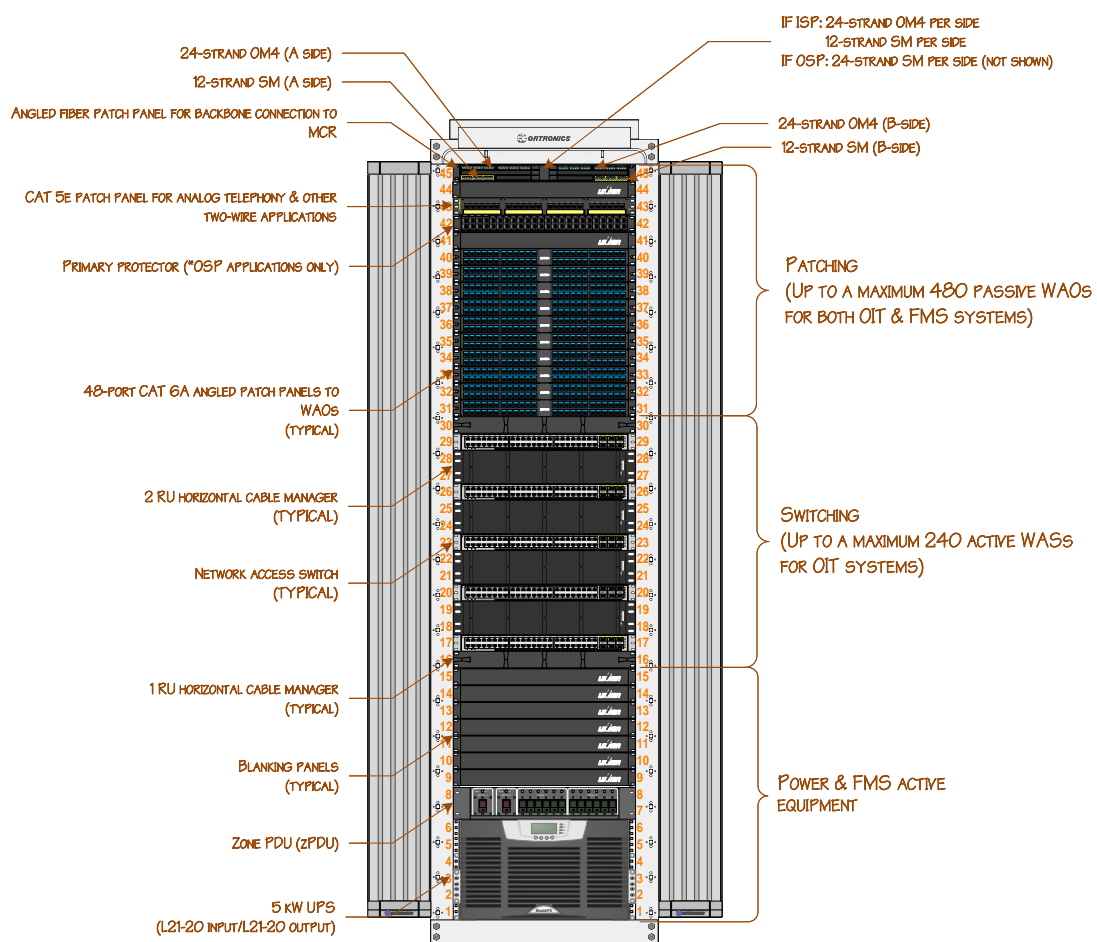

2 ULTIMATE FUTURE CAPACITY – TELECOMMUNICATION ROOM RACKS

1 INITIAL PLANNING CAPACITY – TELECOMMUNICATION ROOM RACKS



PROJECT:

OIT DESIGN GUIDE TEMPLATES

PROJECT No:

N/A

MARK	DATE	DESCRIPTION

ISSUE:

DRAWING No:

FILE: OIT\_Design\_Guide\_Templates-V4 - TD.VSDX

DESIGN BY: KEVIN GRZELKA, CTDC

VERIFIED BY: MICHAEL JULIAN, RCDD  
JOHN WERNAU, KELLY BATES

DOC VERSION No: 4.0

ISSUE DATE: June 1, 2023

SHEET TITLE

RULE OF THIRDS FOR TR RACKS



D

C

B

A

# ***BASIS OF DESIGN EQUIPMENT***

DEPARTMENT OF VETERANS  
AFFAIRS



OFFICE OF INFORMATION AND  
TECHNOLOGY

INFRASTRUCTURE OPERATIONS -  
APPLICATION HOSTING, CLOUD AND  
EDGE SOLUTIONS



ENTERPRISE DATA CENTER AND  
INFRASTRUCTURE ENGINEERING

**EDICT**

ENTERPRISE DATA CENTER  
INFRASTRUCTURE COLLABORATION TEAM

**PROJECT:**

OIT DESIGN GUIDE TEMPLATES

PROJECT No:

N/A

MARK	DATE	DESCRIPTION

ISSUE:

**DRAWING No:**

FILE: OIT\_Design\_Guide\_Templates-V4 - TD.VSDX

DESIGN BY: KEVIN GRZELKA, CTDC

VERIFIED BY: MICHAEL JULIAN, RCDD  
JOHN WERNAU, KELLY BATES

DOC VERSION No: 4.0

ISSUE DATE: June 1, 2023

**SHEET TITLE**

**BASIS OF DESIGN  
EQUIPMENT**

GENREIC TELECOMMUNICATIONS MEDIA AND INTERFACE SPECIFICATIONS FOR TELECOMMUNICATIONS SPACES			
ID	PRIMARY ATTRIBUTE	SECONDARY ATTRIBUTE	SPECIFICATION
1	COPPER PATCH PANELS	PERFORMANCE CATEGORY	CATEGORY 6A (10 GBE)
		POSITION COUNT	48
		FORM FACTOR	ANGLED
		SIZE	ONE RACK UNIT (RU)
		JACK COLOR CODING	A-SIDE BLUE / B-SIDE YELLOW FOR DUAL PATH DISTRO WITHIN COMPUTER ROOMS (DATA CENTERS); UTP DISTRO TO WAOs IS EXCLUDED
2	FIBER DISTRIBUTION PANNELS	CASSETTE CAPACITY	12 CASSETTES OR 6 DOUBLE CASSETTES
		CASSETTE USER INTERFACES	LC DUPLEX CONNECTORS / MPO-8
		CASSETTE BACKBONE INTERFACES	MPO-24/MPO-12
		PERFORMANCE CHARACTERISTICS	OM4 LASER OPTIMIZED 50/125 MULTIMODE (MM) / OS1(OS2) 9/125 SINGLE MODE (SM)
		FORM FACTOR	ONE RU
3	UNSHIELDED TWISTED PAIR (UTP) (HORIZONTAL AND FIRST LEVEL BACKBONE)	PERFORMANCE CATEGORY	CATEGORY 6A (10 GbE); 24-26 GAUGE
		PERFORMANCE SPECIFICATIONS	MEETS OR EXCEEDS TIA-EIA-568-C.2-10, TSB-155.
4	FIBER (HORIZONTAL AND FIRST LEVEL BACKBONE)	PERFORMANCE CATEGORY	OM4 LASER OPTIMIZED / OS1 / OS2
		PERFORMANCE SPECIFICATIONS	LASER OPTIMIZED 50/125 MM FIBERS WITH AT LEAST 4,700 MHZ·KM AT 850 NM / OS1 9/125 SM FIBERS (INTRA-BUILDING) / OS2 9/125 SM (INTER-BUILDING)
		MODE	MULTIMODE/SINGLE MODE
		JACK COLOR	AQUA (OM4) / LIME (OM5) / YELLOW (SM) / BLACK (OSP)
		MEDIA CONNECTOR	PRE-TERMINATE WITH MULTI-FIBER PUSH ON (MPO), (FIELD TERMINATION AUTHORIZED FOR DISTRIBUTION LEAVING THE COMPUTER ROOM)
		STRAND COUNT	12 or 24
		BUNDLING	LOOSE TUBE (OUTDOOR)/TIGHT BUFFERED (INDOOR)
5	UTP PATCH CORDS	PERFORMANCE CATEGORY	CATEGORY 6A, 26-28 GAUGE, STRANDED
		PERFORMANCE SPECIFICATIONS	CENTER TUNED TO HORIZONTAL MEDIA
		TERMINATION METHOD	FACTORY PRE-TERMINATED
6	FIBER PATCH CORDS	PERFORMANCE CATEGORY	OM5/ OM4 / OS1 / OS2
		PERFORMANCE SPECIFICATIONS	LASER OPTIMIZED 50/125 MM FIBERS WITH AT LEAST 4,700 MHZ·KM AT 850 NM / OS1 9/125 SM FIBERS (INTRA-BUILDING) / OS2 9/125 SM (INTER-BUILDING)
		MODE	MULTIMODE/SINGLE MODE
		JACKET COLOR	AQUA (OM4) / LIME (OM5) / YELLOW (SM)
		MEDIA CONNECTOR	PRE-TERMINATED WITH DUPLEX LC / MPO-8



PROJECT:

OIT DESIGN GUIDE TEMPLATES

PROJECT No:

N/A

MARK	DATE	DESCRIPTION

ISSUE:

DRAWING No:

FILE: OIT\_Design\_Guide\_Templates-V4 - TD.VSDX

DESIGN BY: KEVIN GRZELKA, CTDC

VERIFIED BY: MICHAEL JULIAN, RCDD  
JOHN WERNAU, KELLY BATES

DOC VERSION No: 4.0

ISSUE DATE: June 1, 2023

SHEET TITLE

SPECIFICATIONS

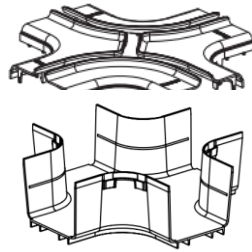
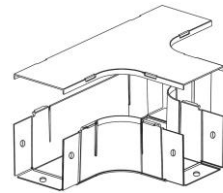
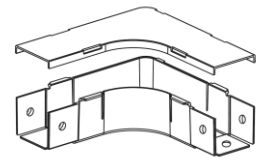

FIBER PATHWAY CHANNEL CORNERS (PANDUIT FR4X4/FRHC4/FRSHC4 OR EQUIVALENT):  
 RIGHT ANGLE CORNER  
 TEE CONER  
 TOUR WAY CROSSING  
 SPLIT OR SOLID COVERS

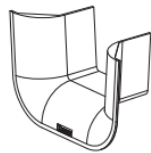
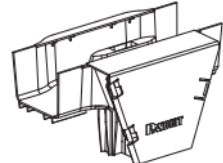

FIBER PATHWAY BEND RADIUS SPILLWAYS (PANDUIT FRVT4X4/FRTR4X4 OR EQUIVALENT):  
 VERTICAL TEE  
 TRUMPET SPILLWAY  
 BEND RADIUS SPILLWAYS REQUIRED AT EVERY RACK LOCATION

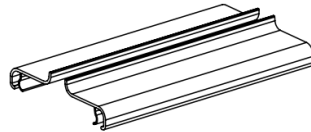
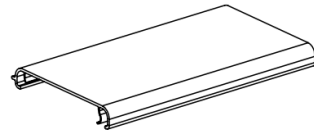
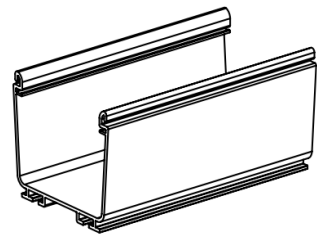

FIBER PATHWAY CHANNEL AND COVERS (PANDUIT FR4X4/FRHC4/FRSHC4 OR EQUIVALENT):  
 4 IN. X 4 IN. CHANNEL RUNNER  
 SOLID COVER  
 SPLIT HINGED COVER

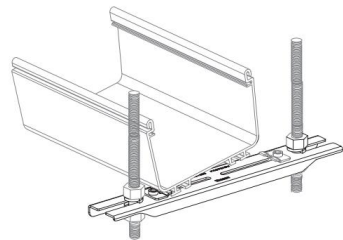
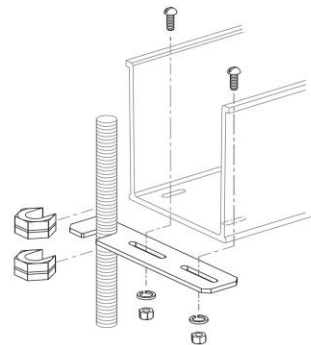

FIBER PATHWAY MOUNTING BRACKET (PANDUIT FR6TRBE/FR6TRBN OR EQUIVALENT):  
 BRACKET TO MOUNT TO EXISTING THREADED ROD OR  
 BRACKET TO MOUNT TO NEW THREADED ROD

2 PROPOSED FIBER PATHWAY AND DETAILS

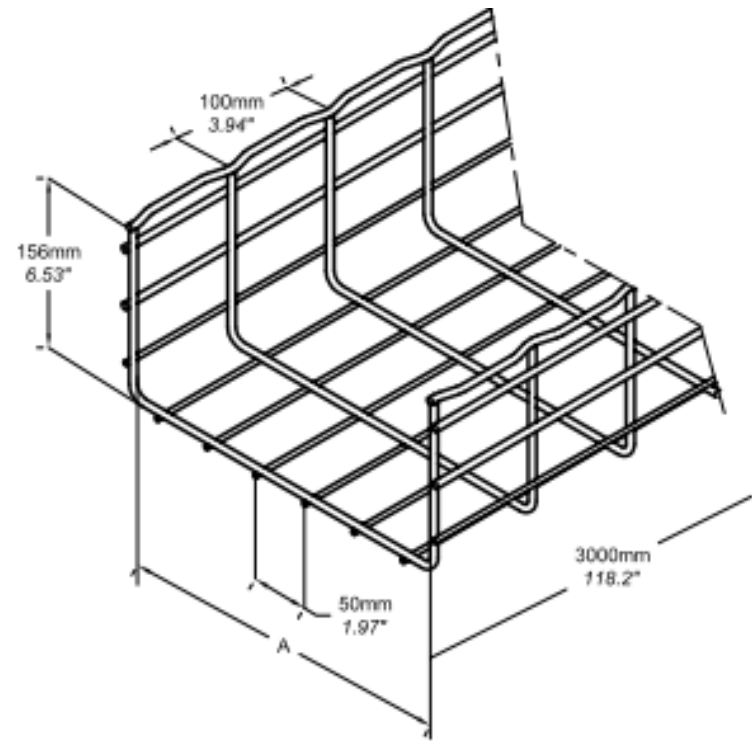

RECOMMENDED CABLE TRAY:

CABLOFIL  
 4 IN. DEEP X 12 IN. WIDE MINIMUM (SIZE COMMENSURATE WITH  
 DISTRIBUTION REQUIREMENT)  
 WHITE POWERCOAT  
 TRAY INSERT

CAT. NO	DEPTH (IN)	WIDTH (IN)	CAT 6a 4-pr PLENUM (0.35 in.)
CF105/300	4	12	248
CF105/450	4	18	373
CF105/500	4	20	414
CF105/600	4	24	497
CF150/150	6	6	186
CF150/200	6	8	238
CF150/300	6	12	357
CF150/450	6	18	536
CF150/500	6	20	596
CF150/600	6	24	715
CF150/900	6	36	1078

1 CABLE TRAY CAPACITY PLANNING



PROJECT:

OIT DESIGN GUIDE TEMPLATES

PROJECT No:

N/A

MARK	DATE	DESCRIPTION

ISSUE:

DRAWING No:

FILE: OIT\_DESIGN\_GUIDE\_TEMPLATES-V4 - TD.VSDX

DESIGN BY: KEVIN GRZELKA, CTDC

VERIFIED BY: MICHAEL JULIAN, RCDD  
JOHN WERNAU, KELLY BATES

DOC VERSION No: 4.0

ISSUE DATE: June 1, 2023

SHEET TITLE

PATHWAY DETAILS



B-SIDE JACK COLOR: YELLOW



RECOMMENDED UTP MEDIA: ATLAS-X1 COPPER TRUNKS

PART NUMBER: CTA-U6APO6LxxxF-CYNXA24N-CYNXA24N-CB01E WHERE xxx IS THE LENGTH IN FT

DESCRIPTION:

CAT 6A UTP CMP CABLE ASSEMBLY; BUNDLE OF 6 BLUE CABLES

BERK-TEK - LANMARK-10G2 (UTP) BRANDED CABLE USED, TIA/EIA WIRING T568B

TESTED TO ANSI/TIA 568.2-D

CUSTOM LABELING, NO PULLING EYE

FIRST END TERMINATION: ATLAS-X1 E2XHD CONNECTOR WITH YELLOW JACK 24 IN. BREAKOUT LENGTH. SECOND

END TERMINATION: ATLAS-X1 E2XHD CONNECTOR WITH YELLOW JACK 24 IN. BREAKOUT LENGTH

3 B-SIDE UTP TRUNK CABLES

A-SIDE JACK COLOR: BLUE



B-SIDE JACK COLOR: YELLOW

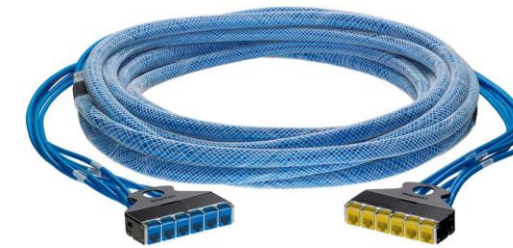

RECOMMENDED UTP MEDIA: ATLAS-X1 COPPER TRUNKS

PART NUMBER: CTA-U6APO6LxxxF-CLNXA24N-CYNXA24N-CB01E WHERE xxx IS THE LENGTH IN FT

DESCRIPTION:

CAT 6A UTP CMP CABLE ASSEMBLY; BUNDLE OF 6 BLUE CABLES

BERK-TEK - LANMARK-10G2 (UTP) BRANDED CABLE USED, TIA/EIA WIRING T568B

TESTED TO ANSI/TIA 568.2-D

CUSTOM LABELING, NO PULLING EYE

FIRST END TERMINATION: ATLAS-X1 E2XHD CONNECTOR WITH BLUE JACK 24 IN. BREAKOUT LENGTH. SECOND END

TERMINATION: ATLAS-X1 E2XHD CONNECTOR WITH YELLOW JACK 24 IN. BREAKOUT LENGTH

4 A-SIDE TO B-SIDE CROSS CONNECT UTP TRUNK CABLES



A-SIDE JACK COLOR: BLUE



RECOMMENDED UTP MEDIA: ATLAS-X1 COPPER TRUNKS

PART NUMBER: CTA-U6APO6LxxxF-CLNXA24N-CLNXA24N-CB01E WHERE xxx IS THE LENGTH IN FT

DESCRIPTION:

CAT 6A UTP CMP CABLE ASSEMBLY; BUNDLE OF 6 BLUE CABLES

BERK-TEK - LANMARK-10G2 (UTP) BRANDED CABLE USED, TIA/EIA WIRING T568B

TESTED TO ANSI/TIA 568.2-D

CUSTOM LABELING, NO PULLING EYE

FIRST END TERMINATION: ATLAS-X1 E2XHD CONNECTOR WITH BLUE JACK 24 IN. BREAKOUT LENGTH. SECOND

END TERMINATION: ATLAS-X1 E2XHD CONNECTOR WITH BLUE JACK 24 IN. BREAKOUT LENGTH

2 A-SIDE UTP TRUNK CABLES

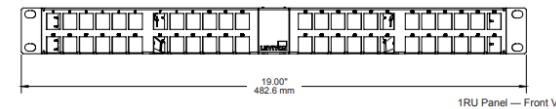
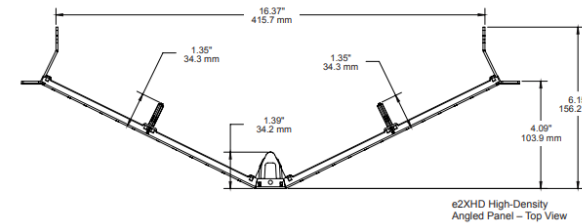

RECOMMENDED UTP PATCH PANEL  
 LEVITON E2XHD-BLK HIGH-DENSITY ANGLED  
 48 POSITION  
 ONE RU PER PANEL  
 WITH REAR CABLE MANAGER  
 ANGLED PANEL COVERS

1 UTP PATCH PANEL

DEPARTMENT OF VETERANS AFFAIRS

OFFICE OF INFORMATION AND TECHNOLOGY

INFRASTRUCTURE OPERATIONS - APPLICATION HOSTING, CLOUD AND EDGE SOLUTIONS

EDICT  
 ENTERPRISE DATA CENTER INFRASTRUCTURE COLLABORATION TEAM

PROJECT:  
 OIT DESIGN GUIDE TEMPLATES

PROJECT No:  
 N/A

MARK	DATE	DESCRIPTION

ISSUE:

DRAWING No:  
 FILE: OIT\_DESIGN\_GUIDE\_TEMPLATES-V4 - TD.VSDX  
 DESIGN BY: KEVIN GRZELKA, CTDC  
 VERIFIED BY: MICHAEL JULIAN, RCDD  
 JOHN WERNAU, KELLY BATES  
 DOC VERSION No: 4.0  
 ISSUE DATE: June 1, 2023

SHEET TITLE  
 UTP MEDIA DETAILS

SHEET: 46 OF 57



RECOMMENDED MPO-8 STANDARD DENSITY FIBER CASSETTE: LEVITON HDX2 UNITY MTP@

PART NUMBER: 42NM2-S5C  
 DESCRIPTION:  
 HDX UNITY MTP@ CASSETTE, (0.75 dB) 24-FIBER OM4, 3x8-FIBER MTP@(MALE) TO 1x24-FIBER MTP@(MALE), 120G TO 40G, BLACK LATCH  
 UNIVERSAL POLARITY CASSETTES

RECOMMENDED MPO-24 TRUNK CABLE: OPT-X™ UNITY ULTRA LOW LOSS MTP@ TRUNK CABLES  
 PART NUMBER: FTU-FW4024JJxxxF36C36CY-NNBS WHERE xxx IS THE LENGTH IN FT  
 DESCRIPTION: FIBER TRUNK UNITY; 24 FIBERS, MULTIMODE OM4; 24F SUB-UNITS OPT-X SJP; FIRST END WITH PULLING EYE, CUSTOM LABEL; POLARITY MTP@ METHOD B; FIRST END CONNECTOR: 24F LLMTP 0.35 DB FEMALE CONNECTOR, BREAKOUT LENGTH OF 36 IN. INTO 3.6 MM JACKETED FIBER, NO STAGGER; SECONDEENDCONNECTOR: 24F LLMTP 0.35 DB FEMALE CONNECTOR, BREAKOUT LENGTH OF 36 IN. INTO 3.6 MM JACKETED FIBER, NNO S STAGGER;

4 FIBER CASSETTES AND TRUNK CABLES (SD MPO-8 BREAKOUT)

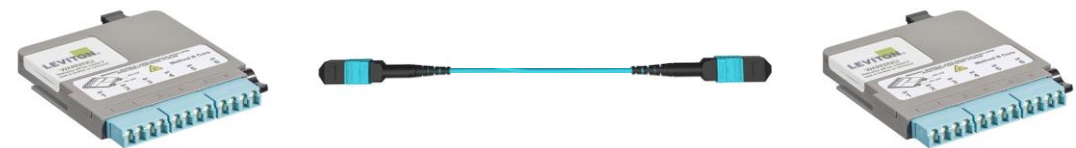

RECOMMENDED LC FIBER CASSETTE: LEVITON HDX2 UNITY MTP@

PART NUMBER: 41LSM4-UNN  
 DESCRIPTION:  
 HDX UNITY MTP@ CASSETTE, (0.35 dB), 12-FIBER OM4, LC SHUTTERED (AQUA) TO 1x12-FIBER MTP@, UNIVERSAL POLARITY, BLACK LATCH  
 UNIVERSAL POLARITY CASSETTES

RECOMMENDED MPO-12 TRUNK CABLE: OPT-X™ UNITY ULTRA LOW LOSS MTP@ TRUNK CABLES  
 PART NUMBER: FTU-FW2012LLxxxF36B36BY-NNBC WHERE xxx IS THE LENGTH IN FT  
 DESCRIPTION: FIBER TRUNK UNITY; 12 FIBERS, MULTIMODE OM4; 12F SUB-UNITS OPT-X SJP; OVERALL CABLE LENGTH OF 100 FT; FIRST END WITH PULLING EYE, CUSTOM LABEL; POLARITY MTP METHOD B; FIRST END CONNECTOR: 12F ULMTP 0.20 DB FEMALE CONNECTOR, BREAKOUT LENGTH OF 36 IN. INTO 2 MM JACKETED FIBER, NO STAGGER; SECOND END CONNECTOR: 12F ULMTP 0.20 DB FEMALE CONNECTOR, BREAKOUT LENGTH OF 36 IN. INTO 2 MM JACKETED FIBER, NO STAGGER;

3 FIBER CASSETTES AND TRUNK CABLES (LC MPO-12 BREAKOUT)



RECOMMENDED LC FIBER CASSETTE: LEVITON HDX2 UNITY MTP@

PART NUMBER: 42LSM2-21C  
 DESCRIPTION:  
 HDX2 UNITY MTP@ CASSETTE, (0.50 dB) 24-FIBER OM4, LC SHUTTERED TO 1x24-FIBER MTP@(MALE), 120G TO 10G, BLACK LATCH  
 UNIVERSAL POLARITY CASSETTES

RECOMMENDED MPO-24 TRUNK CABLE: OPT-X™ UNITY ULTRA LOW LOSS MTP@ TRUNK CABLES  
 PART NUMBER: FTU-FW4024JJxxxF36C36CY-NNBS WHERE xxx IS THE LENGTH IN FT  
 DESCRIPTION: FIBER TRUNK UNITY; 24 FIBERS, MULTIMODE OM4; 24F SUB-UNITS OPT-X SJP; FIRST END WITH PULLING EYE, CUSTOM LABEL; POLARITY MTP METHOD B; FIRST END CONNECTOR: 24F LLMTP 0.35 DB FEMALE CONNECTOR, BREAKOUT LENGTH OF 36 IN. INTO 3.6 MM JACKETED FIBER, NO STAGGER; SECOND END CONNECTOR: 24F LLMTP 0.35 DB FEMALE CONNECTOR, BREAKOUT LENGTH OF 36 IN. INTO 3.6 MM JACKETED FIBER, NO STAGGER;

2 FIBER CASSETTES AND TRUNK CABLES (LC MPO-24 BREAKOUT)



RECOMMENDED LC FIBER SPLICE CASSETTE:  
 LEVITON HDX

PART NUMBER: SPLCH-12AQ (OM4) / SPLCH-12GN (OS2)  
 DESCRIPTION:  
 HDX OM4 LC CASSETTE, (0.15 dB) 12-FIBER OM4 TO 12x1-FIBER LC(UPC)  
 HDX OS2 LC CASSETTE, (0.24 dB) 12-FIBER OS2 TO 12x1-FIBER LC(APC)

5 FIBER SPLICE CASSETTES (LC BREAKOUT)

RECOMMENDED MPO-8 TO MPO-8 PATCH CORDS:



LEVITON OPT-X™ UNITY ULTRA LOW LOSS ARRAY CORDS  
 PART NUMBER: UL548MM-BxxxF WHERE xxx IS THE LENGTH IN FT  
 DESCRIPTION: OPT-X@ UNITY 40-100G MTP@ ARRAY CORD (3 MM ROUND CABLE), MULTIMODE (OM4), 8 FIBERS, ULMTP 8 FIBER FEMALE TO ULMTP 8 FIBER FEMALE, METHOD B POLARITY

RECOMMENDED LC TO LC PATCH CORDS:



LEVITON PREMIUM PLUS FIBER PATCH CORDS

- OM4: PART NUMBER: PCF-M4PD1RR-xxxxF WHERE xxxx IS THE LENGTH IN FT TO 0.5 FT. (EXAMPLE: FOR 5 FT xxxx=0050, FOR 3.5 FT xxxx=0035)  
 DESCRIPTION: PREMIUM PLUS FIBER PATCH CORD, OM4 AQUA, PLENUM, DUP-ZIP 1.6 MM, LC, LC, ULTRA POLISHED CONNECTORS (UPC)
- OS2: PART NUMBER: PCF-S2PD1FF-xxxxFAB WHERE xxxx IS THE LENGTH IN FT TO 0.5 FT. (EXAMPLE: FOR 5 FT xxxx=0050, FOR 3.5 FT xxxx=0035)  
 DESCRIPTION: PREMIUM PLUS FIBER PATCH CORD, OS2 YELLOW, PLENUM, DUP-ZIP 1.6 MM, LC/APC, LC/APC, A-B POLARITY (PART NUMBER PCF-S2PD1FF-xxxxFAA FOR A-A POLARITY)

6 FIBER PATCH CORDS

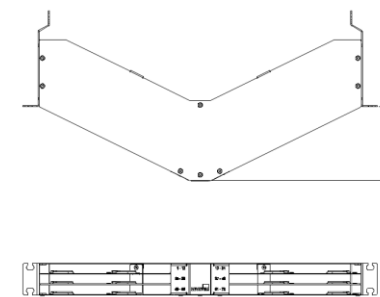

RECOMMENDED FIBER DISTRIBUTION PANEL:  
 LEVITON ANGLED OPT-X™ UHDx  
 144 FIBER  
 ONE RU

1 FIBER DISTRIBUTION PANEL



PROJECT:

OIT DESIGN GUIDE TEMPLATES

PROJECT No:

N/A

MARK	DATE	DESCRIPTION

ISSUE:

DRAWING No:

FILE: OIT\_Design\_Guide\_Templates-V4 - TD.VSDX

DESIGN BY: KEVIN GRZELKA, CTDC

VERIFIED BY: MICHAEL JULIAN, RCDD  
 JOHN WERNAU, KELLY BATES

DOC VERSION No: 4.0

ISSUE DATE: June 1, 2023

SHEET TITLE

FIBER MEDIA DETAILS

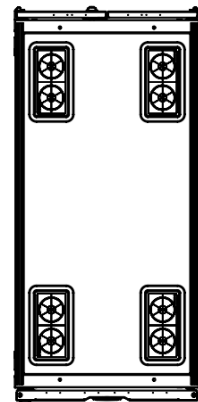

④ TYPICAL SERVER CABINET TOP VIEW WITH FOUR BRUSHED GROMMET CABLE OPENINGS

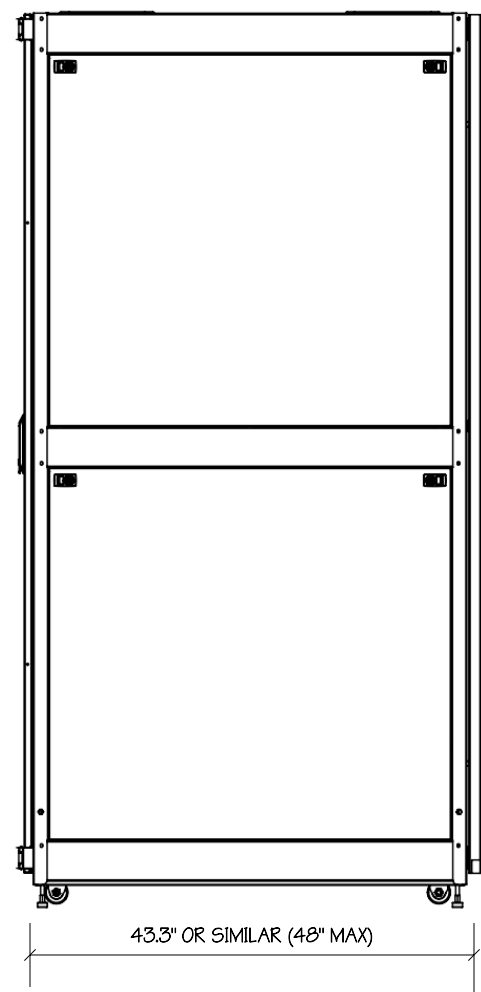

③ TYPICAL SERVER CABINET SIDE VIEW

Note: SERVER CABINETS MAY ONLY HOUSE SERVER AND STORAGE EQUIPMENT AND SUPPORTING PATCH PANELS. SERVER CABINETS MAY NOT HOUSE TELECOMMUNICATIONS (NETWORK) EQUIPMENT.

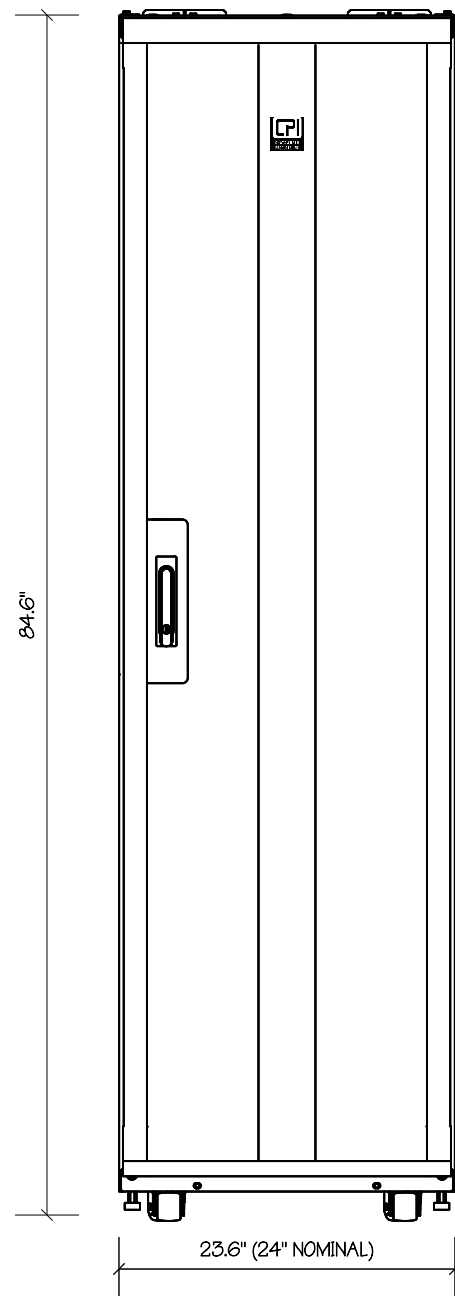

② TYPICAL SERVER CABINET FRONT

### CHATSWORTH ZETAFRAME™ CABINET (PN:ZB14-A222A-E1) OR EQUIVALENT

23.6 IN. (600 MM) W X 43.3 IN. (1100 MM) D X 45R MU; GLACIER WHITE; (1) CASTER ONLY KIT; (1) LEVELER ONLY KIT; (4) SQUARE PUNCHED RAILS WITH NO CABLE OPENINGS; (2) SOLID SIDE PANEL; (1) ZETAFRAME PERFORATED METAL DOOR, GLACIER WHITE; (1) SINGLE-POINT KEYED LOCK; (1) DOUBLE PERFORATED METAL DOOR; (1) THREE-POINT KEYED LOCK; (1) TOP PANEL WITH FOUR (4) BRUSH-SEALED CABLE OPENINGS; (1) BOTTOM PANEL WITH TWO (2) BRUSH-SEALED CABLE OPENINGS; (1) AIR DAM KIT; (1) STANDARD DUAL 2-PIECE PDU BRACKET KIT; (1) COMMON PARTS KIT, ZF, UL; (1) PACKAGING KIT

Z	1	2	3	-	4	5	6	7	8	-	9	10
<b>1. Height</b>												
U	in	mm										
42	79.4	2017	A									
45	84.6	2149	B									
48	89.9	2283	C									
52	96.9	2461	D									
Height includes casters.												
<b>2. Width</b>												
in	mm											
23.6	600	1										
27.6	700	2										
29.5	750	3										
31.5	800	4										
<b>3. Depth</b>												
in	mm											
31.5	800	1										
39.4	1000	2										
41.3	1050	3										
43.3	1100	4										
47.2	1200	5										
Frame depth does not include doors. See detailed dimensions on page 6.												
<b>4. Doors</b>												
None		0										
Single Perforated Front/ Double Perforated Rear		A										
No Front/ Double Perforated Rear		B										
<b>5. Top Panel</b>												
None		0										
Grommet-Sealed		1										
Brush-Sealed		2										
<b>6. Side Panel</b>												
None		0										
1 Side		1										
2 Sides		2										
<b>7. Bottom Panel</b>												
None		0										
Grommet-Sealed		1										
Brush-Sealed		2										
<b>8. Thermal Management</b>												
None		0										
Air Dam		A										
Air Dam, Brushed-Sealed Rail		B										
Brush-Sealed Front Rails are not available for 23.6"W (600 mm) cabinets.												
<b>9. Color</b>												
Black		7										
Glacier White		E										
<b>10. Shipping</b>												
Standard Pallet		1										
Shock Pallet		2										
Shock Pallet is available for 42U, 45U, 48U cabinet heights and 43.3"D (1100 mm) and 47.2"D (1200 mm) cabinet depths.												



① TYPICAL SERVER CABINET SPECIFICATION



PROJECT:

OIT DESIGN GUIDE TEMPLATES

PROJECT No:

N/A

MARK	DATE	DESCRIPTION

ISSUE:

DRAWING No:

FILE: OIT\_DESIGN\_GUIDE\_TEMPLATES-V4 - TD.VSDX

DESIGN BY: KEVIN GRZELKA, CTDC

VERIFIED BY: MICHAEL JULIAN, RCDD  
JOHN WERNAU, KELLY BATES

DOC VERSION No: 4.0

ISSUE DATE: June 1, 2023

SHEET TITLE

TYPICAL SERVER CABINET



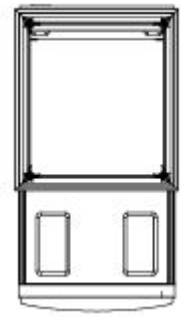

4 TYPICAL ENCLOSURE TOP VIEW WITH VERTICAL EXHAUST DUCT (VED)  
NTS

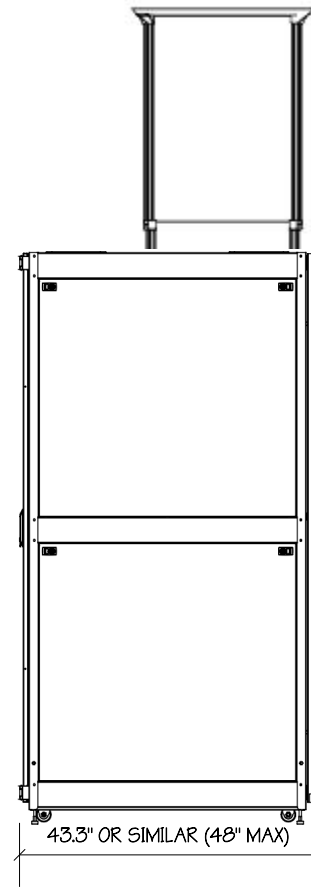

3 TYPICAL ENCLOSURE SIDE VIEW WITH VERTICAL EXHAUST DUCT (VED)  
NTS

NOTE: SERVER CABINETS MAY ONLY HOUSE SERVER AND STORAGE EQUIPMENT AND SUPPORTING PATCH PANELS. SERVER CABINETS MAY NOT HOUSE TELECOMMUNICATIONS (NETWORK) EQUIPMENT

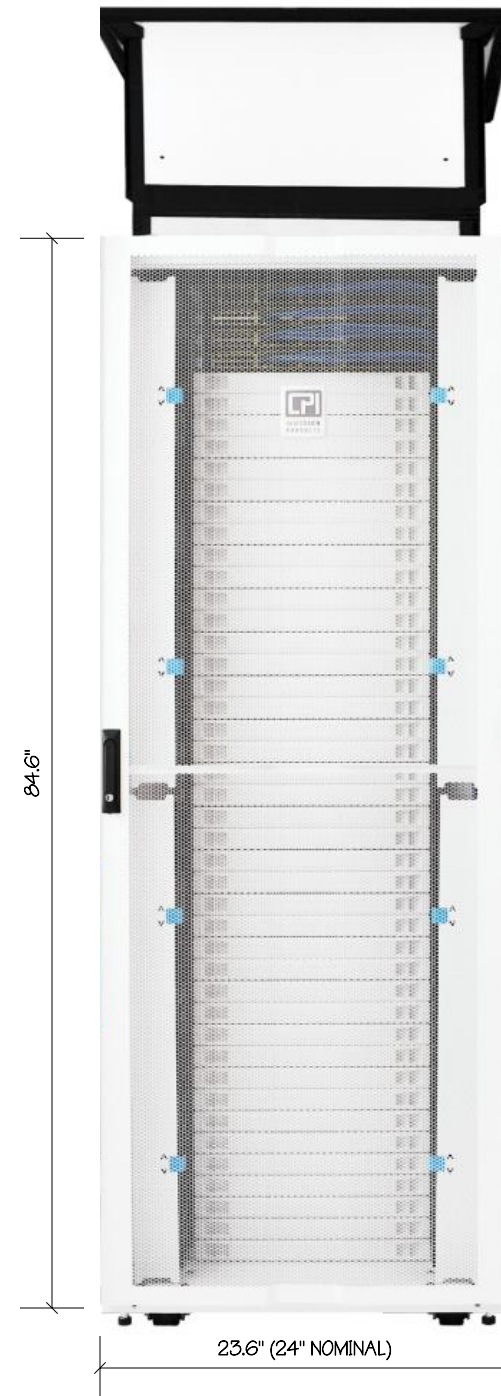

2 TYPICAL ENCLOSURE FRONT WITH VERTICAL EXHAUST DUCT (VED)  
NTS

### CHATSWORTH ZETAFRAME™ CABINET (PN:ZB14-Dx22A-E1) OR EQUIVALENT

ZETAFRAME CABINET; 84.6 IN. H X 23.6 IN. W X 43.3 IN. D (2149 MM X 600 MM X 1100 MM); 45 RU; 2 PAIR SQUARE PUNCHED RAILS; PERF FRONT DOOR; SOLID REAR DOOR; VED 20 IN. H-34 IN. H (508 MM – 863 MM); 2 SIDE PANELS; BRUSH BOTTOM PANEL; AIR DAM; STANDARD PALLET; GLACIER WHITE

VED SIZE DEPENDS UPON FINAL ELEVATION DRAWINGS

1. Height		2. Width		3. Depth		4. Doors		5. Top Panel		6. Side Panel		7. Bottom Panel		8. Thermal Management		9. Color		10. Shipping	
U	in	mm	in	mm	in	mm													
42	79.4	2017	23.6	600	41.3	1050	Single Perforated Front/ Single Solid Rear	A	15-20" H (381 - 508 mm) Vertical Exhaust Duct	0	None	A	Air Dam	7	Black	1	Standard Pallet		
45	84.6	2149	27.6	700	43.3	1100	No Front/ Single Solid Rear	B	20-34" H (508 - 863 mm) Vertical Exhaust Duct	1	Grommet-Sealed	B	Air Dam, Brushed-Sealed Front Rail	E	Glacier White	2			
48	89.9	2283	29.5	750	47.2	1200		C	34-60" H (863 - 1524 mm) Vertical Exhaust Duct	2	Brush-Sealed								
52	96.9	2461						D	15-20" H (381 - 508 mm) Vertical Exhaust Duct, Air Director										
								E	20-34" H (508 - 863 mm) Vertical Exhaust Duct, Air Director										
								F	34-60" H (863 - 1524 mm) Vertical Exhaust Duct, Air Director										

*Height includes casters.*

*Brush-Sealed Front Rails are not available for 23.6"W (600 mm) cabinets.*

*Frame depth does not include doors. See detailed dimensions on page 6.*

*At least one side panel between adjacent cabinets and bottom panel are recommended for optimal thermal performance.*

*A half brush seal is included at the lower rear of the duct.*



1 TYPICAL ENCLOSURE SPECIFICATION  
NTS



MARK	DATE	DESCRIPTION

ISSUE:

DRAWING No:  
FILE: OIT\_Design\_Guide\_Templates-V4 - TD.VSDX  
DESIGN BY: KEVIN GRZELKA, CTDC  
VERIFIED BY: MICHAEL JULIAN, RCDD  
JOHN WERNAU, KELLY BATES  
DOC VERSION No: 4.0  
ISSUE DATE: June 1, 2023

SHEET TITLE

TYPICAL SERVER CABINET WITH VERTICAL EXHAUST DUCT

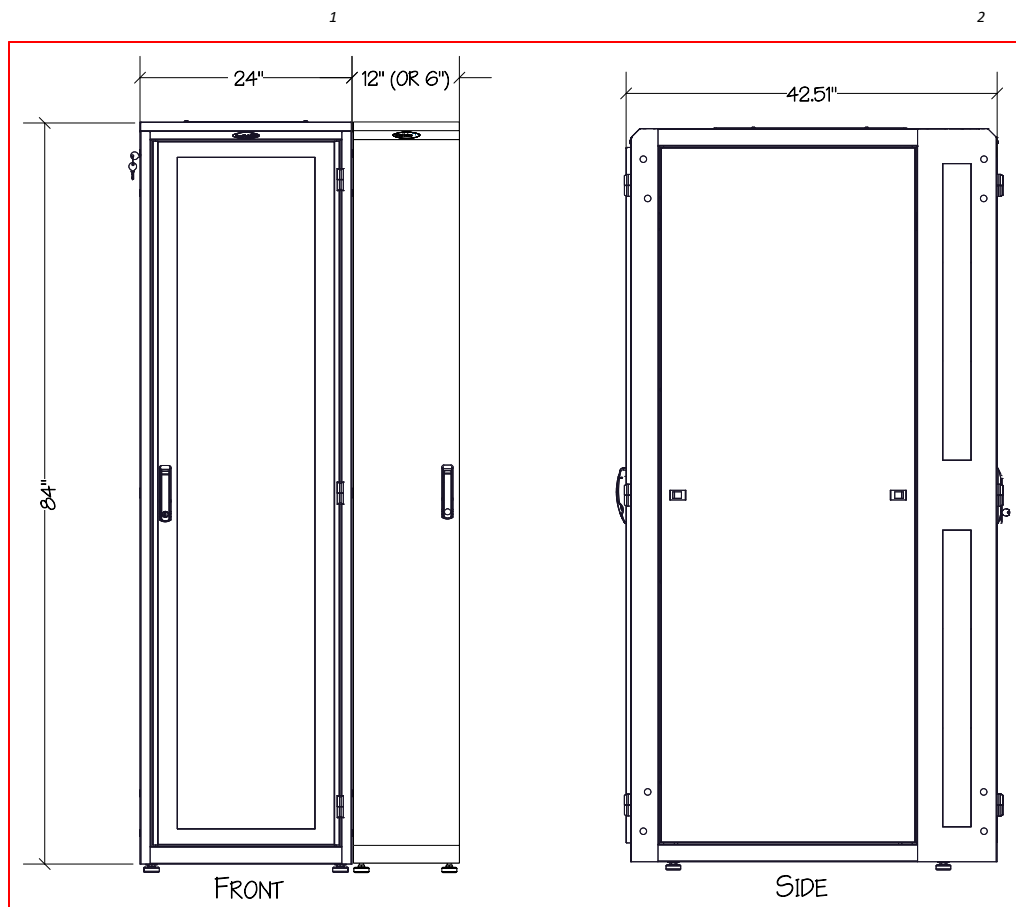

4 TYPICAL NETWORK CABINET (WITH SIDECAR) FRONT AND SIDE VIEW DIMENSIONS

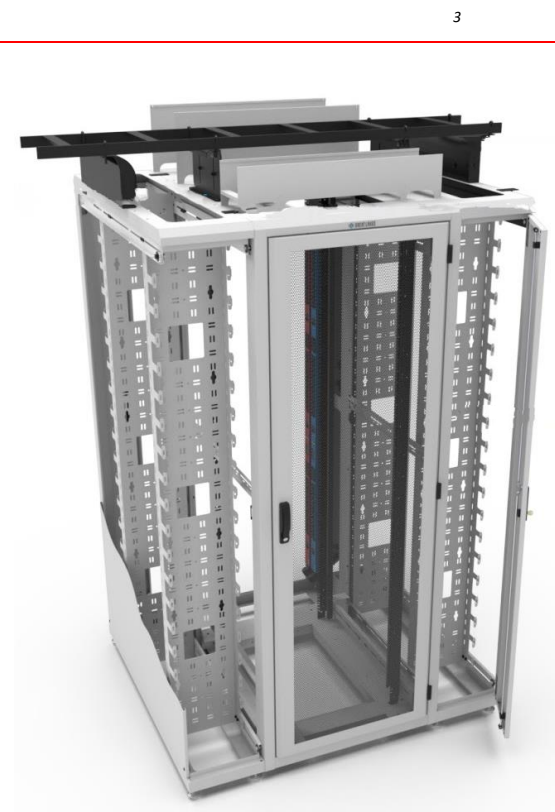

5 PHOTOGRAPHIC ISOMETRIC VIEW OF CABINET WITH SIDECARS

NOTE: NETWORK CABINETS ARE PURPOSE BUILT TO PROVIDE AMPLE ROOM FOR CABLING NEEDS OF THE HORIZONTAL DISTRIBUTION AREA AND THE MAIN DISTRIBUTION AREA AND MAY BE USED IN LIEU OF TELECOMMUNICATION CHANNEL RACKS FOR THIS PURPOSE. TELECOMMUNICATION CABINETS MAY NOT BE USED IN TELECOMMUNICATIONS ROOMS.

GREAT LAKES CASE AND CABINET ES CABINET (GL840ES-2442-W-MSS) OR EQUIVALENT

- 84 IN. H X 24 IN. W X 42 IN. D
- 44 RU
- 40 IN. USABLE DEPTH
- 35 IN. MAX. RAIL SPACING
- 3300 LB. WEIGHT CAPACITY
- WINTER CHITE
- INCLUDES: FRAME WITH LEVELERS (2.5 IN. H) AND TWO PAIRS OF PDU BRACKETS; MESH CONTOUR FRONT DOOR; SPLIT MESH REAR DOOR; SOLID (2) SIDE PANEL; 3/8 IN. SQ. (M6) MOUNTING RAILS WITH RACK MOUNT HARDWARE; SOLID TOP PANEL
- UL2416
- SHIPPING DIMS: 89 IN. H X 32 IN. W X 45 IN. D; 416 LB.

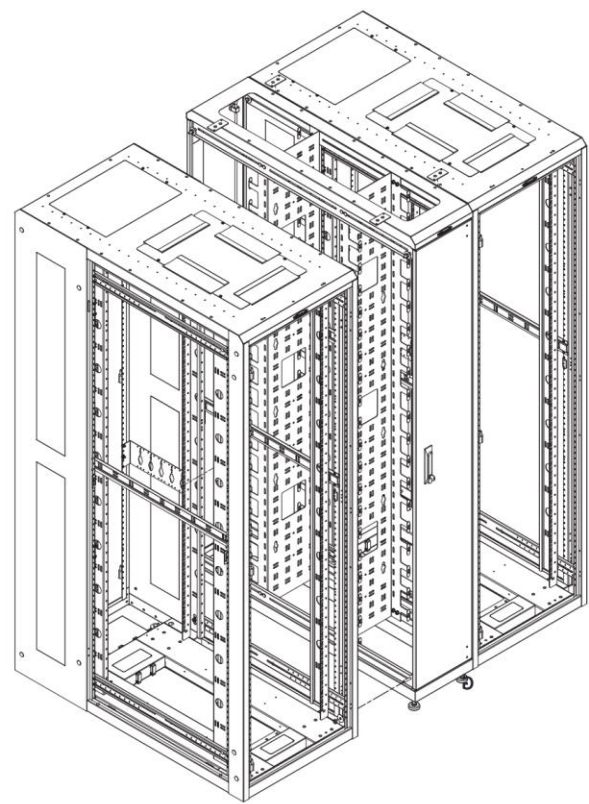

3 TYPICAL NETWORK CABINET ISOMETRIC VIEW

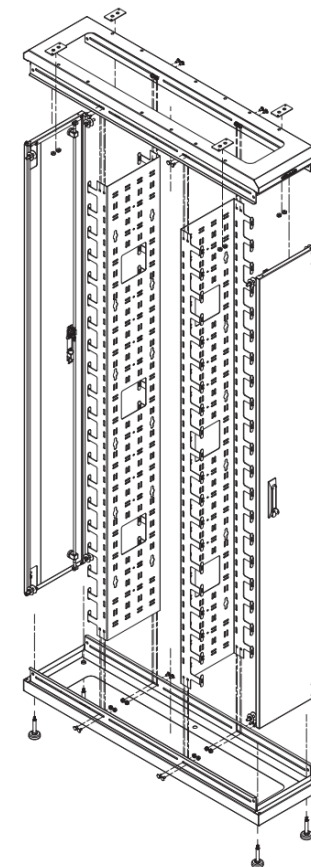

GREAT LAKES CASE AND CABINET CABLE MANAGEMENT SIDECAR (SC128442 OR SC68442) OR EQUIVALENT

- 84 IN. H X 6 IN. W (OR 12 IN. W) X 42 IN. D
- INCLUDES DEPTH ADJUSTABLE TROUGHS
- DUAL-HINGE FRONT AND REAR DOORS
- USE WITH ES CABINETS

2 TYPICAL CABLE MANAGEMENT SIDECAR

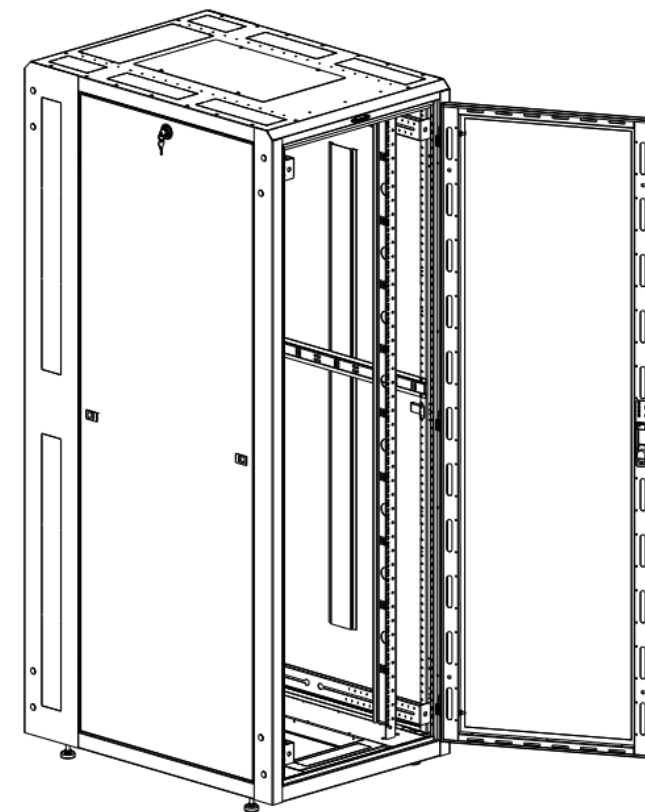

1 TYPICAL NETWORK CABINET SPECIFICATION

DEPARTMENT OF VETERANS AFFAIRS



OFFICE OF INFORMATION AND TECHNOLOGY

INFRASTRUCTURE OPERATIONS - APPLICATION HOSTING, CLOUD AND EDGE SOLUTIONS



ENTERPRISE DATA CENTER AND INFRASTRUCTURE ENGINEERING

**EDICT**

ENTERPRISE DATA CENTER INFRASTRUCTURE COLLABORATION TEAM

PROJECT:

OIT DESIGN GUIDE TEMPLATES

PROJECT No:

N/A

MARK	DATE	DESCRIPTION

ISSUE:

DRAWING No:

FILE: OIT\_DESIGN\_GUIDE\_TEMPLATES-V4 - TD.VSDX

DESIGN BY: KEVIN GRZELKA, CTDC

VERIFIED BY: MICHAEL JULIAN, RCDD  
JOHN WERNAU, KELLY BATES

DOC VERSION No: 4.0

ISSUE DATE: June 1, 2023

SHEET TITLE

TYPICAL NETWORK CABINET

SHEET: 50 OF 57

NOTE: NETWORK CABINETS ARE PURPOSE BUILT TO PROVIDE AMPLE ROOM FOR CABLING NEEDS OF THE HORIZONTAL DISTRIBUTION AREA AND THE MAIN DISTRIBUTION AREA AND MAY BE USED IN LIEU OF TELECOMMUNICATION CHANNEL RACKS FOR THIS PURPOSE. TELECOMMUNICATION CABINETS MAY NOT BE USED IN TELECOMMUNICATION ROOMS.

GREAT LAKES CASE AND CABINETS EXHAUST CHIMNEY OR EQUIVALENT

GL-EC-42-3246 CHIMNEY, 32-46 IN. 42 IN. D ES SIZES

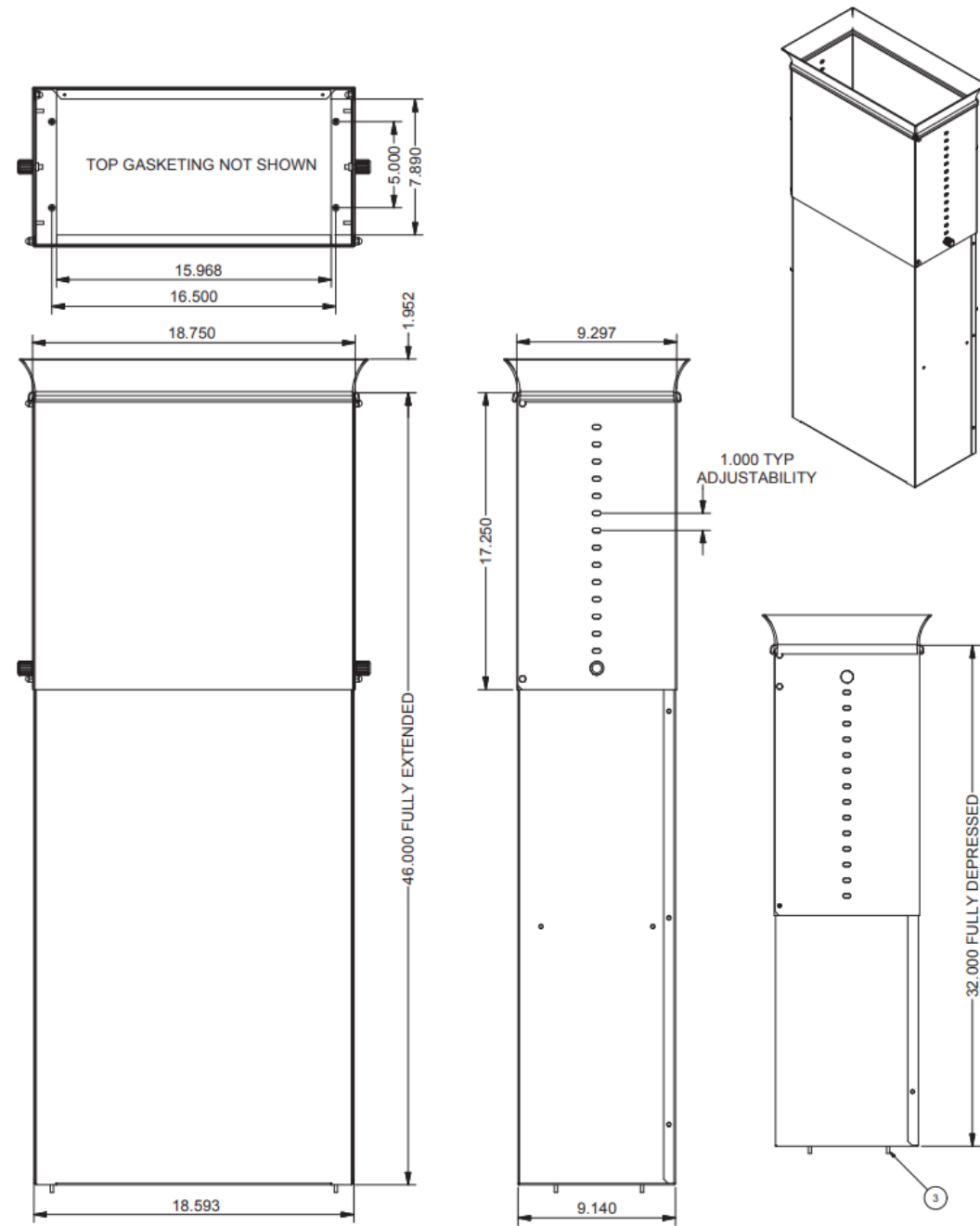

2 TYPICAL RACK WITH VERTICAL EXHAUST DUCT FRONT AND SIDE VIEW DIMENSIONS

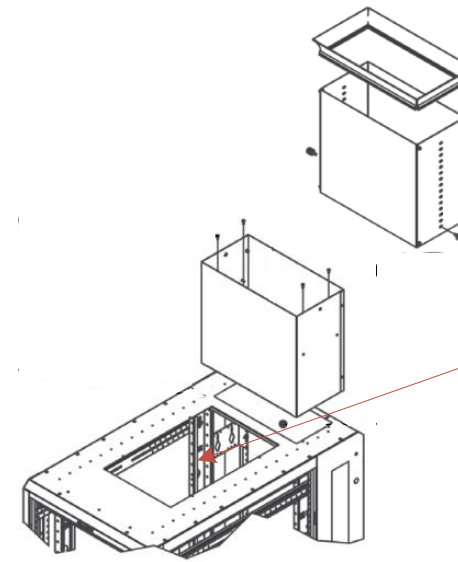

USE TOP PANEL BRUSH GROMMET FOR ES CABINET (TPES-B) OR EQUIVALENT

3 TYPICAL RACK WITH VERTICAL EXHAUST DUCT ISOMETRIC VIEW

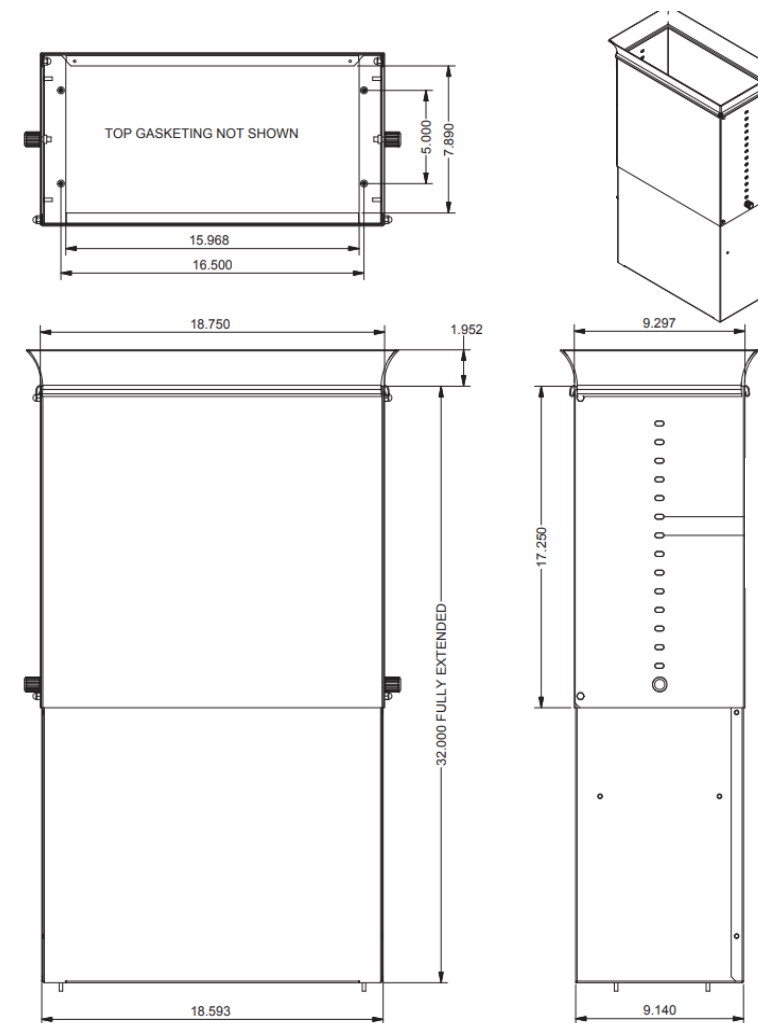

GREAT LAKES CASE AND CABINETS EXHAUST CHIMNEY PR EQUIVALENT

GL-EC-42-1832 CHIMNEY, 18-32 IN. 42 IN. D ES SIZES

1 TYPICAL RACK WITH VERTICAL EXHAUST DUCT FRONT AND SIDE VIEW DIMENSIONS



PROJECT:

OIT DESIGN GUIDE TEMPLATES

PROJECT No:

N/A

MARK	DATE	DESCRIPTION

ISSUE:

DRAWING No:

FILE: OIT\_Design\_Guide\_Templates-V4 - TD.VSDX

DESIGN BY: KEVIN GRZELKA, CTDC

VERIFIED BY: MICHAEL JULIAN, RCDD  
JOHN WERNAU, KELLY BATES

DOC VERSION No: 4.0

ISSUE DATE: June 1, 2023

SHEET TITLE

TYPICAL NETWORK CABINET WITH VERTICAL EXHAUST DUCT

BRUSH GROMMET CHIMNEY KNOCKOUT

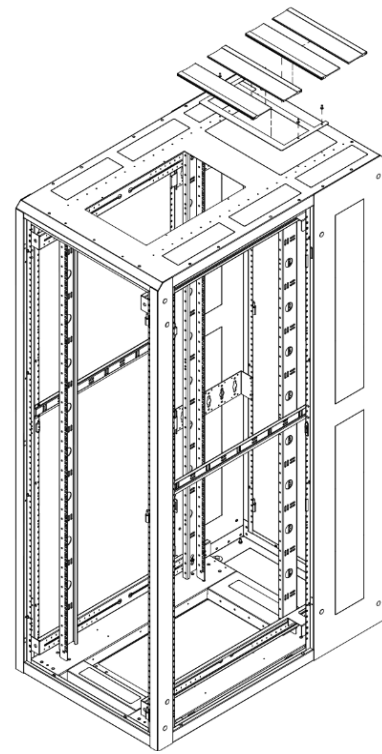

BRUSH GROMMET (AND EDGE GROMMET) TO COVER CABLE PASS-THRU KNOCKOUTS

USE FOR TOP CHIMNEY KNOCKOUT ON 42 IN. D ES CABINETS WHEN VERTICAL EXHAUST DUCT IS NOT USED

④ TYPICAL BRUSH GROMMETS – CHIMNEY KNOCKOUT

TOP PANEL BRUSH GROMMET FOR ES CABINETS (TPES-B) OR EQUIVALENT

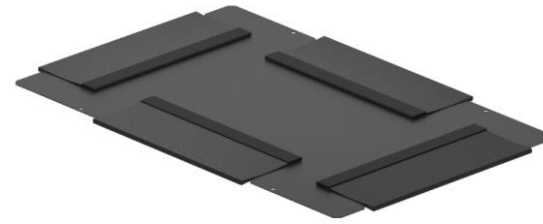

⑥ TYPICAL TOP PANEL COVER WITH BRUSH GROMMETS

BRUSH GROMMET RAIL KIT  
BGRK-84-24 OR EQUIVALENT  
84 IN. H X 24 IN. W ES SIZES

OPTIONAL BREAKAWAY TRIM  
BRUSH STRIP WITH FLEXIBLE PVC TRIM

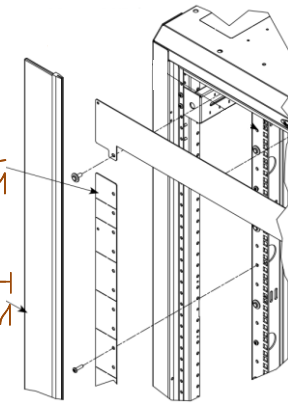

⑤ TYPICAL BRUSH GROMMETS – FRONT RAILS

SEISMIC ANCHOR KIT INCLUDES 4 TORQUE CONTROLLED EXPANSION ANCHORS  
AK101 OR EQUIVALENT

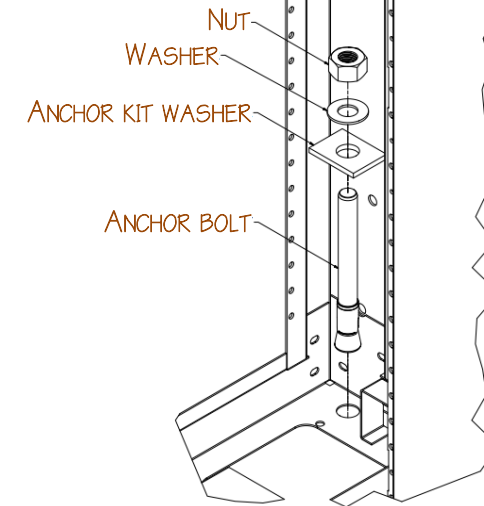

⑦ TYPICAL SEISMIC ANCHOR KIT

BRUSH GROMMET FOR CABLE PASS THRU (BGS-84) OR EQUIVALENT

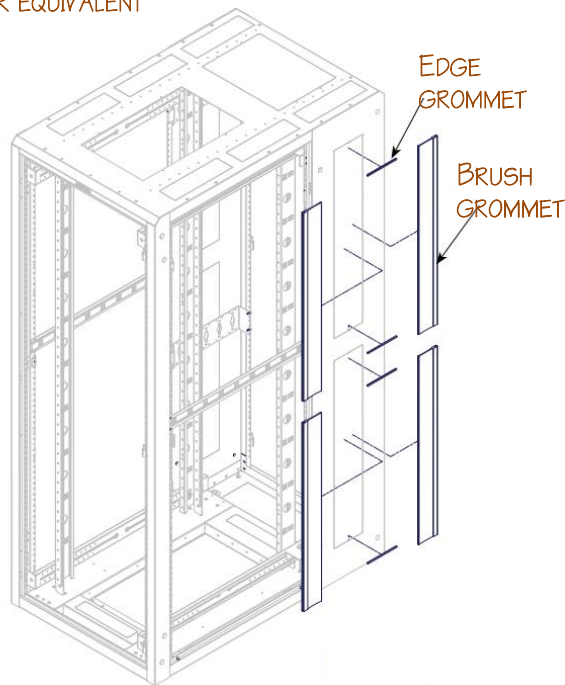

EDGE GROMMET  
BRUSH GROMMET

③ TYPICAL BRUSH GROMMETS – SIDE WALL PASS THRU

CABLE MANAGEMENT FINGERS

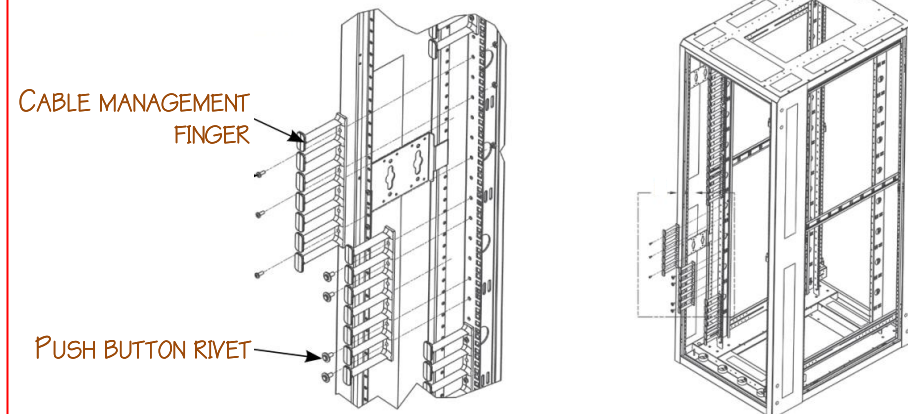

CABLE MANAGEMENT FINGER

PUSH BUTTON RIVET

CM-47 4 IN. X 7 RMU, SINGLE FINGER SECTION  
ESC-K12 4 IN. X 7 RMU, SET OF 12 FINGER SECTIONS  
CM-77 7 IN. X 7 RMU, SINGLE FINGER SECTION  
ESC-K12-7 7 IN. X 7 RMU, SET OF 12 FINGER SECTIONS OR EQUIVALENT

② TYPICAL CABLE MANAGEMENT FINGERS

CM-25 KIT OF 10, 1/4 TURN "D" RINGS, 1.5 IN. X 3.5 IN. OR EQUIVALENT

CM-26 KIT OF 10, 1/4 TURN "D" RINGS, 3.5 IN. X 5 IN. OR EQUIVALENT

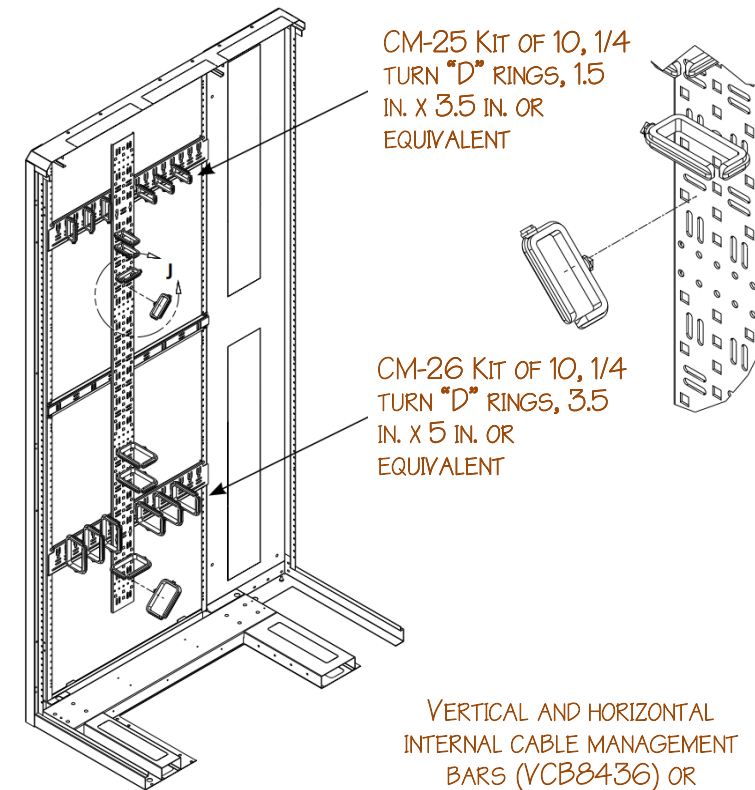

VERTICAL AND HORIZONTAL INTERNAL CABLE MANAGEMENT BARS (VCB8436) OR EQUIVALENT

① TYPICAL CABLE MANAGEMENT BARS



PROJECT:

OIT DESIGN GUIDE TEMPLATES

PROJECT No:

N/A

MARK	DATE	DESCRIPTION

ISSUE:

DRAWING No:

FILE: OIT\_Design\_Guide\_Templates-V4 - TD.VSDX

DESIGN BY: KEVIN GRZELKA, CTDC

VERIFIED BY: MICHAEL JULIAN, RCDD  
JOHN WERNAU, KELLY BATES

DOC VERSION No: 4.0

ISSUE DATE: June 1, 2023

SHEET TITLE

TYPICAL NETWORK CABINET ACCESSORIES



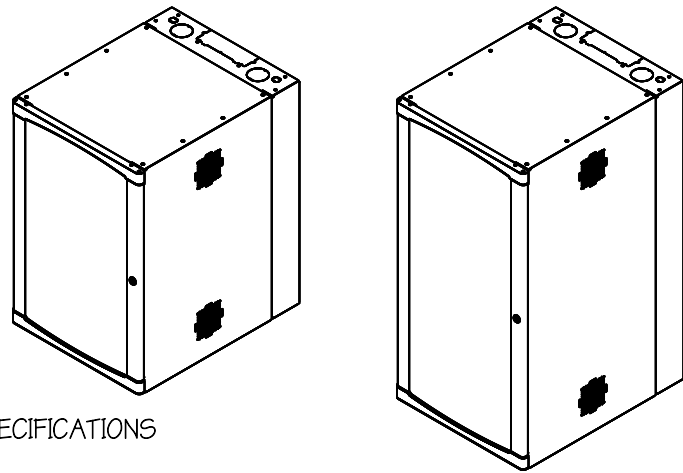

**SPECIFICATIONS**

**DESCRIPTION:**

WALL-MOUNT ENCLOSURE WITH LOCKABLE FRONT DOOR AND SWING-OUT REAR ACCESS TO EQUIPMENT. TEMPERED GLASS FRONT DOOR

**26 RU:**

CUBE-IT WALL-MOUNT CABINET; GEN 3; 48 IN. H X 24 IN. W X 30 IN. D (1220 MM X 610 MM X 760 MM); 26 RU; #12-24 TAPPED RAILS; TEMPERED GLASS ROOR; GLACIER QHTE. 12419-E48 CUBE-IT OR EQUIVALENT

**12 RU:**

CUBE-IT WALL-MOUNT CABINET; GEN 3; 24 IN. H X 24 IN. W X 30 IN. D (610 MM X 610 MM X 760 MM); 12 RU; #12-24 TAPPED RAILS; TEMPERED GLASS DOOR; GLACIER WHITE. 12419-E24 CUBE-IT OR EQUIVALENT

**USE:**

FOR INDOOR USE ONLY, IN ENVIRONMENTALLY CONTROLLED AREAS; MAY NOT BE USED OUTDOORS, IN HARSH ENVIRONMENTS, OR IN AIR-HANDLING SPACES

**SIZE:**

HEIGHT: 48 IN. (1220 MM)  
 WIDTH: 24 IN. (610 MM); 19 IN. EIA RACK-MOUNT  
 DEPTH: 30 IN. (760 MM)

**INTERIOR:**

HEIGHT: 26 RU  
 WIDTH: 19 IN. EIA RACK-MOUNT  
 THREADED #12-24 EQUIPMENT MOUNTING HOLES  
 19 IN. W, EIA-310-D COMPLIANT  
 FAN ASSEMBLIES WITH FILTER KITS

**4 SPECIFICATIONS**

**Cable Port Brush Kit for CUBE-IT Wall-Mount Cabinet**

- Optional cover when rectangular knockout on the rear panel is removed
- Seals opening around cables with brush seal
- Sold in pairs



Part Number	Description	Shipping Weight lb (kg)
25190-000	0.8"H x 10.6"W x 2.9"D (20 mm x 268 mm x 74 mm)	2 (0.9)

**3 BRUSH KIT (ONE PER CABINET)**

**Equipment Mounting Rail Kit for CUBE-iT Wall-Mount Cabinet**

- Use with equipment that needs front and rear support
- Sold in pairs
- Aluminum material

Part Number	Description	Shipping Weight lb (kg)
12787-524	12U; For 24"H (610 mm) cabinet	4 (1.8)
12787-536	19U; For 36"H (910 mm) cabinet	6 (2.7)
12787-548	26U; For 48"H (1220 mm) cabinet	8 (3.6)



**9 FRONT AND REAR RAIL KIT**

**Low-Decibel Dual-Fan and Filter Kit for CUBE-iT Wall-Mount Cabinet**

- Pressurizes interior of the cabinet, forcing warm air out of open vents
- Assembly includes 2 fans and 2 filters
- Noise Level: 31 dB (measured at 3' (1 m) distance)
- Recommended placement on bottom right and left sides of the cabinet
- Airflow: 120 CFM (204 CMH)
- 50/16 Hz
- 6'L (1.8 m) NEMA 5-15P/6-15P Power Cord



Part Number	Description	Shipping Weight lb (kg)
40975-001	115 Volt, 5-15P power cord	4 (1.8)
40975-002	230 Volt, 6-15P Power cord	4 (1.8)

**7 FAN KIT QTY 1 PER CABINET**

- FOR USE WITH SMALL EQUIPMENT SUCH AS MODEMS, ROUTERS AND FIBER MODULES IN 19 IN. EIA RACKS
- 1 RU; INCLUDES MULTIPLES TIE-DOWN POINTS
- SUPPORTS UP TO 20 LB (9.1 KG) OF EQUIPMENT

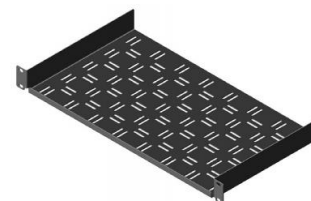

**5 SHELF (TWO PER CABINET)**

**Vertical Cabling Section for CUBE-iT Wall-Mount Cabinet**

- Attaches to the outside edge of equipment mounting rails
- 4U height; openings align with rack-mount unit spaces on equipment mounting rails
- Sold in pairs
- Order additional kits as-needed per cable management requirements

Part Number	Description	Shipping Weight lb (kg)
40970-704	4U, 7"H x 0.5"D (178 mm x 13 mm)	3 (1.4)
40970-707	7U, 12.3"H x 0.5"D (311 mm x 13 mm)	3 (1.4)
40970-711	11U, 19.3"H x 0.5"D (489 mm x 13 mm)	4 (1.8)

Color is black.



**2 VERTICAL CABLE MANAGEMENT. TWO KITS FOR 26 RU TE. ONE KIT FOR 12 RU TE**

**Replacement Filter Kit for CUBE-iT Wall-Mount Cabinet**

- Compatible with Low-Decibel Dual-Fan and Standard Fan kits

Part Number	Description	Shipping Weight lb (kg)
40973-001	Pack of 5	2 (0.9)



**LED Light Kit for CUBE-iT Cabinets**

- Attaches to the bottom, top or side of CUBE-iT Cabinets
- Toggle switch, 4W LED light
- Detachable, 120 VAC with NEMA 1-15P Power Cord

Part Number	Description	Shipping Weight lb (kg)
12803-701	LED Light Kit, 4W, 120 Vac	2 (0.9)

**8 FAN FILTER KIT AND LIGHT KIT(ONE PER CABINET).**

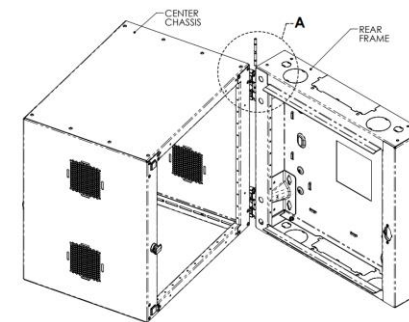

LOAD CAPACITY (per UL2416): 300 lb (163kg)

**6 REAR HINGE AND PANEL**

**Ground Jumpers**

- Provide common bonding from equipment rack or cabinet to halo conductor
- Available individually or in packages of 10
- Constructed of UL Listed components

Part Number	Description	Shipping Weight lb (kg)
40159-009	9' (2.7 m) Ground Jumper, 1 Each	2 (0.9)
40159-019	9' (2.7 m) Ground Jumper, 10 Each	20 (1.9)



**1 REQUIRED GROUND JUMPERS**



**PROJECT:**

OIT DESIGN GUIDE TEMPLATES

PROJECT No:

N/A

MARK	DATE	DESCRIPTION

**ISSUE:**

**DRAWING No:**

FILE: OIT\_Design\_Guide\_Templates-V4 - TD.VSDX

DESIGN BY: KEVIN GRZELKA, CTDC

VERIFIED BY: MICHAEL JULIAN, RCDD  
JOHN WERNAU, KELLY BATES

DOC VERSION No: 4.0

ISSUE DATE: June 1, 2023

**SHEET TITLE**

TYPICAL TE CABINET

1

2

3

4



30 A THREE-PHASE ZONE PDU BASE UNIT – REAR CIRCUITS WITH FOUR L21-20R AND SIX NEMA 5-20 OUTLETS AND TWO 10 FT POWER CORDS TERMINATING IN L21-30P ZONIT ZPDS-208V30A-L21-4L21-20R-CR OR EQUIVALENT

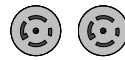

ZONE PDU INPUTS REQUIRE TWO L21-30RS

NOTE: THE CORRECT SPECIFICATION FOR THE ZONE PDU IS TO ENERGIZE IT FROM TWO INDEPENDENT POWER SOURCES. EACH INPUT WILL USE IDENTICAL SPECS: WYE (5-WIRE), 208 V, 30 A, THREE-PHASE, TERMINATING IN A NEMA L21-30R LOCKING RECEPTACLE. THE NEUTRAL CONDUCTOR SHOULD BE UPSIZED ONE GAUGE TO MATCH THE UPSIZED NEUTRAL CONDUCTORS IN THE ZONE PDU UNITS. THE NEUTRAL "UPSIZING" SHOULD IDEALLY BE CONTINUED IN THE POWER DISTRIBUTION SYSTEM BACK TO THE UPS OR TRANSFORMER WINDING POLE. THIS INCREASES THE EFFICIENCY OF THE POWER DISTRIBUTION SYSTEM AND SUPPRESSES HARMONICS IN THE SYSTEM.

4 TYPICAL 30A ZONE PDU



60 A THREE-PHASE ZONE PDU BASE UNIT - REAR SIX L21-20R OUTPUT RECEPTACLES WITH 10 FT POWER CORDS TERMINATING IN HARDWIRE BOX ZONIT ZPDS-208V60A-HW-6L21-20R OR EQUIVALENT

SPECIFICATIONS: RATED INPUT VOLTAGE: 208 V THREE-PHASE; AMPERAGE: 60 A INPUT CORD TERMINATION: HARDWIRE BOX OUTPUT RECEPTACLES: SIX L21-20R OUTPUT BRANCH CIRCUIT PROTECTION: INDIVIDUAL 20 A CIRCUIT BREAKERS PROTECT EACH OUTPUT PHASE OF EACH OUTPUT RECEPTACLE

NOTE: THE CORRECT SPECIFICATION FOR THE ZONE PDU IS TO ENERGIZE IT FROM TWO INDEPENDENT POWER SOURCES. EACH INPUT WILL USE IDENTICAL SPECS: WYE (5-WIRE), 208 V, 60 A, THREE-PHASE, TERMINATING IN A JUNCTION BOX TO BE HARDWIRED INTO THE ZONE PDU. THE NEUTRAL CONDUCTOR SHOULD BE UPSIZED ONE GAUGE TO MATCH THE UPSIZED NEUTRAL CONDUCTORS IN THE ZONE PDU UNITS. THE NEUTRAL "UPSIZING" SHOULD IDEALLY BE CONTINUED IN THE POWER DISTRIBUTION SYSTEM BACK TO THE UPS OR TRANSFORMER WINDING POLE. THIS INCREASES THE EFFICIENCY OF THE POWER DISTRIBUTION SYSTEM AND SUPPRESSES HARMONICS IN THE SYSTEM.

5 TYPICAL 60A ZONE PDU



APC AP9560 OR EQUIVALENT RACK MOUNT PDU; L5-30 PLUG; (10) NEMA 5-20 OUTLETS; 1 RU; TWO PER ENCLOSURE; ONE ENERGIZED BY UPS; ONE ENERGIZED BY WALL OUTLET



REQUIRES ONE L5-30R

NOTE: USED IN TELECOMMUNICATIONS ENCLOSURES ONLY

3 120V RACK PDU FOR TEs



APC AP8861 RPDU OR EQUIVALENT; RACK PDU 2G, METERED; L21-20 PLUG; THREE-PHASE; 120/208 V INPUT; 20 A; ZERO U; 5.7 kW, 208V, (36) C13 & (6) C19 & (2) 5-20 OUTLETS; FOR USE IN TELECOMMUNICATIONS ROOMS AND LOCATIONS WITH LEGACY 110 V ONLY EQUIPMENT



REQUIRES ONE L21-20R

NOTE: USED IN TELECOMMUNICATIONS ROOMS AND ENTRANCE ROOMS WHERE 110 V DISTRIBUTION USING NEMA 5-15 OR NEMA 5-20 RECEPTACLES ARE REQUIRED IN ADDITION TO THE STANDARD 208 V

2 208V RACK PDU FOR TRS AND ENTRANCE ROOMS

CHATSWORTH ECONNECT PDU OR EQUIVALENT; VERTICAL; MONITORED; L21-20 PLUG; THREE-PHASE; 120/208 V INPUT; 20 A; (30) C13 (6) C19 OUTLETS; 208 V OUTPUT; 3 x 2P 20 A; LCD; ETHERNET, USB, AND ENVIRONMENTAL SENSOR PORTS; IP AND SERIAL MONITORING; IP CONSOLIDATION (PDU LINKING); TOOL-LESS MOUNTING; 70.5 IN. H (1791 MM) x 2.2 IN. W (56 MM) x 2.2 IN. D (56 MM)



REQUIRES ONE L21-20R

1 208V RACK PDU FOR COMPUTER ROOMS



PROJECT:

OIT DESIGN GUIDE TEMPLATES

PROJECT No:

N/A

MARK	DATE	DESCRIPTION

ISSUE:

DRAWING No:

FILE: OIT\_Design\_Guide\_Templates-V4 - TD.VSDX

DESIGN BY: KEVIN GRZELKA, CTDC

VERIFIED BY: MICHAEL JULIAN, RCDD  
JOHN WERNAU, KELLY BATES

DOC VERSION No: 4.0

ISSUE DATE: June 1, 2023

SHEET TITLE

TYPICAL RACK AND ZONE PDUS



EATON 93PM (93PM-L FOR 208 V MODEL)

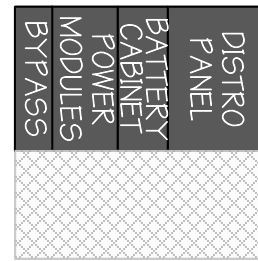

- CLEARANCE
  - FRONT: 36 IN.
  - BACK (TOP EXHAUST): 0 IN.
  - BACK (REAR EXHAUST): 10 IN.
- BATTERY CABINET
  - 16.7 IN. FOR SMALL
  - 34.2 IN. FOR LARGE
- DISTRIBUTION PANEL
  - 31.3 IN.
- BYPASS
  - 14.69 IN. FOR 480 V
  - 12.45 IN. FOR 208 V
- POWER MODULES
  - 480 V
    - 30-150 kW – 22 IN.
    - 160-200 kW – 32 IN.
  - 208 V
    - 10-120 kW – 22 IN.
    - 10-160 kW – 34.4 IN.

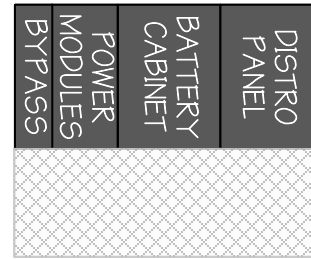

10-200 kW MODULAR UPS  
 FRAME COMMENSURATE WITH COMPUTER ROOM ULTIMATE CAPACITY; POWER MODULES BUILT OUT TO N+1 INTERNAL REDUNDANCY BASED ON CRITICAL LOAD ONLY REQUIRES FRONT CLEARANCE

3 MODULAR UPS OPTION FOR COMPUTER ROOMS



APC SYMMETRA PX 10-100

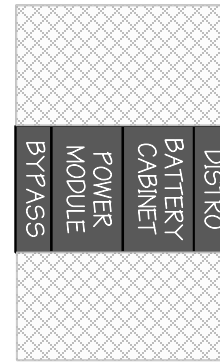

- CLEARANCE
  - FRONT: 36 IN.
  - REAR: 40 IN.
- BATTERY CABINET
  - 23.62 IN.
- DISTRIBUTION PANEL
  - 11.8 IN.
- BYPASS
  - 11.8 IN.
- POWER MODULES
  - 23.62 IN.

10-100 kW MODULAR UPS  
 FRAME COMMENSURATE WITH COMPUTER ROOM ULTIMATE CAPACITY; POWER MODULES BUILT OUT TO N+1 INTERNAL REDUNDANCY BASED ON CRITICAL LOAD REQUIRES FRONT AND REAR CLEARANCE

4 MODULAR UPS OPTION FOR COMPUTER ROOMS



RACK MOUNT UPS. L5-30 INPUT. L5-30 OUTPUT. CAPACITY NTE 2880 VA. 2 RU. METERED (APC SMX3000RMLV2U OR EQUIVALENT)



2 RACK-MOUNT 2.88 kW UPS FOR TEs

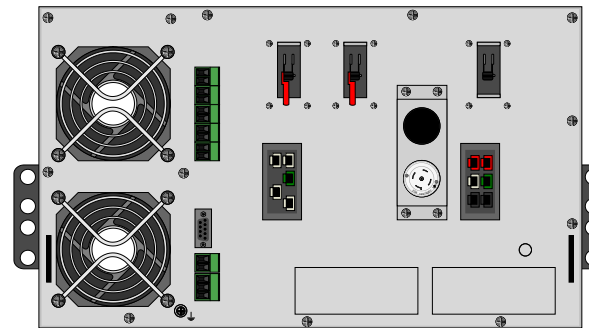

RACK MOUNT UPS.  
 CAPACITY: 5 kW (EXTERNAL BATTERY MODULES AVAILABLE)  
 INPUT VOLTAGE: 208 V  
 INPUT CONNECTION: L21-20P, THREE-PHASE, FOUR-WIRE + GROUND  
 OUTPUT CONNECTION: L21-20R  
 SIZE: 6 RU, 19 IN. RACK-MOUNTABLE  
 RUNTIME: 16.5 MINUTES AT 50% LOAD (EATON BLADEUPS ZC0517700110000 OR EQUIVALENT)

1 RACK-MOUNT 5 kW UPS FOR TRs AND ENTRANCE ROOMS



PROJECT:

OIT DESIGN GUIDE TEMPLATES

PROJECT No:

N/A

MARK	DATE	DESCRIPTION

ISSUE:

DRAWING No:

FILE: OIT\_Design\_Guide\_Templates-V4 - TD.VSDX

DESIGN BY: KEVIN GRZELKA, CTDC

VERIFIED BY: MICHAEL JULIAN, RCDD  
JOHN WERNAU, KELLY BATES

DOC VERSION No: 4.0

ISSUE DATE: June 1, 2023

SHEET TITLE

TYPICAL UPSs



1

2

3

4

FRONT OF RACK

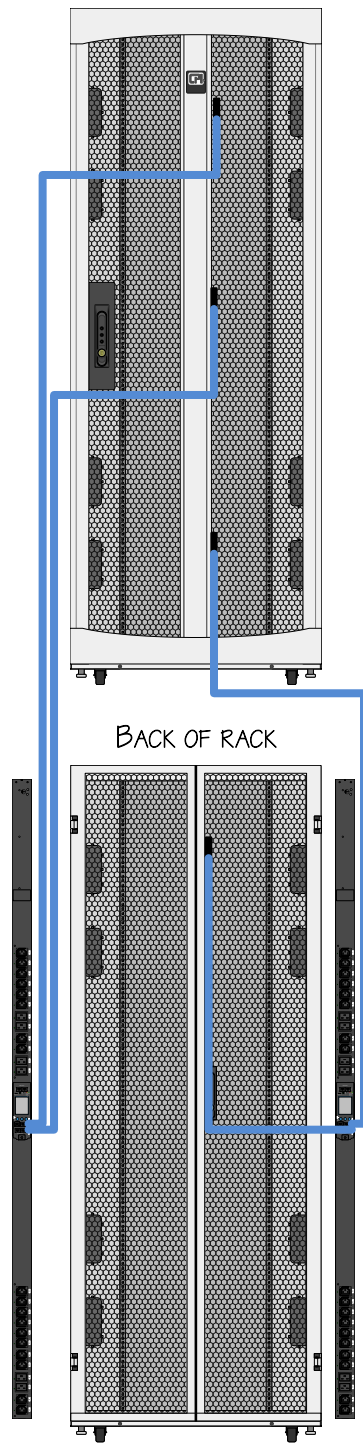

BACK OF RACK

② TEMPERATURE AND HUMIDITY SENSOR LOCATIONS AND CONNECTIONS



CHATSWORTH 14665-001  
USB TEMPERATURE AND  
HUMIDITY SENSOR (OR  
EQUIVALENT)

① TEMPERATURE AND HUMIDITY SENSOR

DEPARTMENT OF VETERANS AFFAIRS



OFFICE OF INFORMATION AND TECHNOLOGY

INFRASTRUCTURE OPERATIONS - APPLICATION HOSTING, CLOUD AND EDGE SOLUTIONS



ENTERPRISE DATA CENTER AND INFRASTRUCTURE ENGINEERING

EDCT

ENTERPRISE DATA CENTER INFRASTRUCTURE COLLABORATION TEAM

PROJECT:

OIT DESIGN GUIDE TEMPLATES

PROJECT No:

N/A

MARK	DATE	DESCRIPTION

ISSUE:

DRAWING No:

FILE: OIT\_DESIGN\_GUIDE\_TEMPLATES-V4 - TD.VSDX

DESIGN BY: KEVIN GRZELKA, CTDC

VERIFIED BY: MICHAEL JULIAN, RCDD  
JOHN WERNAU, KELLY BATES

DOC VERSION No: 4.0

ISSUE DATE: June 1, 2023

SHEET TITLE

TYPICAL TEMPERATURE AND HUMIDITY MONITORING

SHEET: 57 OF 57