

UNIFIED FACILITIES CRITERIA (UFC)

PIERS AND WHARVES



UNIFIED FACILITIES CRITERIA (UFC)

PIERS AND WHARVES

Any copyrighted material included in this UFC is identified at its point of use.
Use of the copyrighted material apart from this UFC must have the permission of the
copyright holder.

U.S. ARMY CORPS OF ENGINEERS

NAVAL FACILITIES ENGINEERING \1\ SYSTEMS /1/ COMMAND (Preparing Activity)

AIR FORCE CIVIL ENGINEER CENTER

Record of Changes (changes are indicated by \1\ ... /1/)

Change No.	Date	Location
1	28 Aug 2024	<ul style="list-style-type: none">• Various format updates and editorial changes throughout.• Chapter 1 mandatory paragraphs updated.• Added definition of a Type IIA 'Hybrid' General Purpose/Repair pier.• Chapter 2, various requirements.

This UFC supersedes UFC 4-152-01, dated 28 July 2005 with Change 1, dated 1 September 2012.

FOREWORD

The Unified Facilities Criteria (UFC) system is prescribed by MIL-STD 3007 and provides planning, design, construction, sustainment, restoration, and modernization criteria, and applies to the Military Departments, the Defense Agencies, and the DoD Field Activities in accordance with [USD \(AT&L\) Memorandum](#) dated 29 May 2002. UFC will be used for all DoD projects and work for other customers where appropriate. All construction outside of the United States, its territories, and possessions is also governed by Status of Forces Agreements (SOFA), Host Nation Funded Construction Agreements (HNFA), and in some instances, Bilateral Infrastructure Agreements (BIA). Therefore, the acquisition team must ensure compliance with the most stringent of the UFC, the SOFA, the HNFA, and the BIA, as applicable.

UFC are living documents and will be periodically reviewed, updated, and made available to users as part of the Military Department's responsibility for providing technical criteria for military construction. Headquarters, U.S. Army Corps of Engineers (HQUSACE), Naval Facilities Engineering Systems Command (NAVFAC), and Air Force Civil Engineer Center (AFCEC) are responsible for administration of the UFC system. Technical content of UFC is the responsibility of the cognizant DoD working group. Defense Agencies should contact the respective DoD Working Group for document interpretation and improvements. Recommended changes with supporting rationale may be sent to the respective DoD working group by submitting a Criteria Change Request (CCR) via the Internet site listed below.

UFC are effective upon issuance and are distributed only in electronic media from the following source:

- Whole Building Design Guide web site <http://www.wbdg.org/ffc/dod>.

Refer to UFC 1-200-01, *DoD Building Code*, for implementation of new issuances on projects.

AUTHORIZED BY:

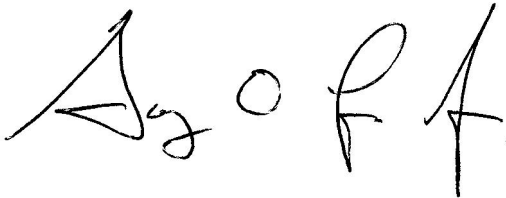

GEORGE O. LEA, P.E.
Chief, Military Engineering Branch
U.S. Army Corps of Engineers



JOSEPH E. GOTT, P.E.
Chief Engineer
Naval Facilities Engineering Command



EDWIN H. OSHIBA, SES, DAF
Deputy Director of Civil Engineers
DCS/Logistics, Engineering &
Force Protection



MICHAEL McANDREW
Director, Facilities Investment and Management
Office of the Deputy Under Secretary of Defense
(Installations and Environment)

**UNIFIED FACILITIES CRITERIA (UFC)
REVISION SUMMARY SHEET**

Document: UFC 4-152-01, *DESIGN: PIERS AND WHARVES*

Superseding: UFC 4-152-01, *DESIGN: PIERS AND WHARVES*, dated 28 July 2005 with Change 1, dated 1 September 2012.

Description of Change: UFC 4-152-01, *DESIGN: PIERS AND WHARVES* represents another step in the joint services effort to bring uniformity to the planning, design and construction of piers and wharves. This UFC contains extensive modifications in the following areas:

- Loads and seismic considerations
- Fender Systems
- Camels
- UFC general updates and revisions

Reasons for Change: The existing guidance was inadequate for the following reasons:

- Incorporation of changes described above
- Update to referenced documents

Impact: The following direct benefits will result from the update of 4-152-01, *DESIGN: PIERS AND WHARVES*:

- Although primarily a U.S. Navy document, a single, comprehensive, up to date criteria document exists to cover design of piers and wharves.
- Eliminates misinterpretation and ambiguities that could lead to design and construction conflicts.
- Facilitates updates and revisions and promotes agreement and uniformity of design and construction between the Services.

Service Exceptions: None.

TABLE OF CONTENTS

CHAPTER 1 INTRODUCTION	1
1-1 PURPOSE AND SCOPE.....	1
1-2 APPLICABILITY.....	1
1-3 GENERAL FUNCTION.....	1
1-4 CATEGORIES.....	2
1-4.1 Type I – Fueling, Ammunition, and Supply.	2
1-4.2 Type II – General Purpose.....	2
1-4.3 Type III – Repair.	4
1-4.4 Type IV – Specialized.	5
1-5 FLEXIBILITY OF BERTHS.....	5
1-6 APPURTENANCES AND FEATURES.....	5
1-7 GENERAL BUILDING REQUIREMENTS.	6
1-8 GLOSSARY.....	6
1-9 REFERENCES.	6
CHAPTER 2 FACILITY PLANNING	7
2-1 LOCATION AND ORIENTATION.....	7
2-1.1 General.....	7
2-1.2 Orientation for Environmental Conditions.	7
2-1.3 Vessel Ingress and Egress.	8
2-1.4 Water Depth.....	11
2-1.5 Dolphins.....	11
2-2 COORDINATION OF REPAIR.	12
2-2.1 General.....	12
2-3 OVERALL DIMENSIONS AND CLEARANCES.	13
2-3.1 General.....	13
2-3.2 Pier and Wharf Length.....	18
2-3.3 Pier and Wharf Width.....	20
2-3.4 Slip.....	31
2-3.5 Pier and Wharf Deck Elevation.	33
2-4 UTILITIES.....	34
2-4.1 General.....	34

2-5	LIGHTING.....	35
2-5.1	Topside Lighting.	35
2-5.2	Lower Deck Lighting.	35
2-5.3	Underdeck Lighting.....	36
2-6	SECURITY.....	36
2-7	LANDSIDE APPROACHES.	36
2-7.1	Function.....	36
2-7.2	Roadway Width.....	36
2-7.3	Walkway Width.	36
2-7.4	Roadway Deck Elevation.....	37
2-7.5	Number of Approaches.....	37
2-7.6	Turning Room.....	37
2-7.7	Barriers.....	37
2-8	STRUCTURAL TYPES.....	38
2-8.1	General.....	38
2-8.2	Selection of Type.....	41
2-8.3	Construction.....	44
2-9	HYDRAULIC FILL.	52
CHAPTER 3	LOAD REQUIREMENTS.....	53
3-1	GENERAL.....	53
3-2	DEAD LOADS.....	53
3-2.1	General.....	53
3-2.2	Unit Weights.	53
3-3	VERTICAL LIVE LOADS.	54
3-3.1	General.....	54
3-3.2	Uniform Loading.	54
3-3.3	Truck Loading.	54
3-3.4	Rail-Mounted Crane Loading.....	56
3-3.5	Mobile Crane Loadings.....	59
3-3.6	Forklift and Straddle Carrier Loadings.	62
3-3.7	Loading on Railroad Tracks.....	62
3-3.8	Buoyancy.....	62

3-3.9	Wave Loading.....	62
3-3.10	Application of Loadings.....	65
3-4	HORIZONTAL LOADS.....	66
3-4.1	Berthing Energy.....	66
3-4.2	Mooring Loads.....	66
3-4.3	Wind Loads on Structures.....	67
3-4.4	Loads on Piles.....	67
3-4.5	Loads on Utilities.....	68
3-4.6	Earthquake Loads.....	68
3-4.7	Earth and Water Pressures on Retaining Structures.....	72
3-4.8	Thermal Loads.....	73
3-4.9	Ice Forces.....	73
3-4.10	Shrinkage.....	75
3-4.11	Creep.....	75
3-5	LOAD COMBINATIONS.....	75
3-5.1	General.....	75
3-5.2	Load Symbols.....	75
3-5.3	Load and Resistance Factor Design (LRFD).....	76
3-5.4	Service Load Design/Allowable Stress Design (ASD).....	76
CHAPTER 4	STRUCTURAL DESIGN.....	79
4-1	CONSTRUCTION MATERIALS.....	79
4-1.1	Timber.....	79
4-1.2	Steel.....	80
4-1.3	Concrete.....	80
4-1.4	Composites.....	81
4-1.5	Aluminum.....	82
4-1.6	Plastics.....	82
4-2	ALLOWABLE STRESSES.....	83
4-2.1	General.....	83
4-2.2	Timber.....	83
4-2.3	Steel.....	83
4-2.4	Castings.....	83

4-2.5	Concrete.....	83
4-2.6	Other Materials.....	83
4-3	DECK STRUCTURE DESIGN.....	84
4-3.1	Deck Framing.....	84
4-3.2	Pile Caps.....	86
4-3.3	Tabletop Pile Caps.....	87
4-4	SUBSTRUCTURE DESIGN.....	90
4-4.1	Geotechnical.....	90
4-4.2	Pile Bent Framing.....	90
4-5	MOORING HARDWARE.....	91
4-5.1	General.....	91
4-5.2	Hardware Types.....	92
4-5.3	Strength.....	93
4-5.4	Placement.....	94
4-6	MOORING DOLPHINS/PLATFORMS.....	94
4-6.1	Design.....	94
4-6.2	Construction.....	94
4-7	MISCELLANEOUS CONSIDERATIONS.....	95
4-7.1	Expansion Joints.....	95
4-7.2	Drainage.....	95
4-7.3	Bullrail.....	96
4-7.4	Utility Trench.....	96
4-7.5	Utility Hoods.....	101
4-7.6	Wearing Course.....	101
CHAPTER 5	FENDER SYSTEMS.....	103
5-1	GENERAL CONSIDERATIONS.....	103
5-1.1	Description.....	103
5-1.2	Berthing Practice.....	103
5-1.3	Camels and Separators.....	103
5-1.4	Systems Approach.....	104
5-1.5	Functional Requirements.....	105
5-2	BERTHING ENERGY DETERMINATION.....	106

5-2.1	Methods.....	106
5-3	TYPES OF FENDER SYSTEMS.....	112
5-3.1	General.....	112
5-3.2	Fender Piles.....	112
5-3.3	Fenders.....	116
5-4	SELECTION AND DESIGN OF FENDER SYSTEMS.....	125
5-4.1	General.....	125
5-4.2	Fender System Behavior.....	128
5-4.3	Evaluation of Fender Systems.....	129
5-4.4	Fender System Design.....	132
5-4.5	Corner Protection.....	134
5-4.6	Support Chains.....	134
5-4.7	Chocks and Wales.....	134
CHAPTER 6	CAMELS AND SEPARATORS.....	137
6-1	FUNCTION AND APPLICATION.....	137
6-1.1	Hull Maintenance.....	137
6-1.2	Overhangs and projections.....	137
6-1.3	Special Hull Treatments.....	137
6-1.4	Submarine Berthing.....	137
6-1.5	Multiple Berthing (Nesting).....	137
6-1.6	Fender Protection.....	138
6-2	CAMELS.....	138
6-2.1	Log Camels.....	138
6-2.2	Timber Camels.....	138
6-2.3	Steel Pontoon Camels.....	138
6-2.4	Deep-Draft Camels.....	139
6-2.5	Hydro-Pneumatic Fenders.....	139
6-2.6	Composite Camels.....	140
6-2.7	Loads.....	140
6-3	GEOMETRY.....	141
6-3.1	Length and Width.....	141
6-3.2	Depth.....	141

6-4	STABILITY.....	141
6-5	LOCATION.....	141
6-6	MISCELLANEOUS CONSIDERATIONS.....	141
6-6.1	Protection.....	141
6-6.2	Buoyancy Tanks.....	142
6-6.3	Abrasion.....	142
6-6.4	Service Life.....	142
6-7	STANDARD CAMEL DESIGNS.....	142
6-7.1	Submarine Camels.....	142
6-7.2	Aircraft Carrier Camels.....	143
6-8	SEPARATORS.....	146
CHAPTER 7 ACCESS.....		149
7-1	GENERAL.....	149
7-2	SAFETY.....	149
7-2.1	Fall Protection.....	149
7-3	LANDING FLOAT.....	150
7-3.1	Materials.....	150
7-3.2	Mooring Systems.....	150
7-3.3	Live Loads.....	150
7-3.4	Freeboard.....	151
7-3.5	Fendering.....	151
7-3.6	Fittings.....	151
7-3.7	Finish.....	152
7-3.8	Concrete Float Elements.....	152
7-4	BROW OR GANGWAY.....	152
7-4.1	Length.....	152
7-4.2	Widths.....	152
7-4.3	Construction.....	152
7-4.4	Live Load.....	152
7-4.5	Handrails.....	152
7-4.6	Safety.....	153
7-5	BROW PLATFORMS.....	153

7-6	BROW AND PLATFORM DESIGNS.....	153
7-7	WALKWAY OR CATWALK.	153
7-7.1	Width.....	153
7-7.2	Live Load.	154
7-7.3	Construction.....	154
7-7.4	Handrails.....	154
7-8	RAMPS.....	154
7-9	SAFETY LADDERS AND LIFE RINGS.....	156
7-9.1	Safety Ladders.....	156
7-9.2	Life Rings.....	156
APPENDIX A REFERENCES.....		159
A-1	GOVERNMENT PUBLICATIONS.	159
A-2	NON-GOVERNMENT PUBLICATIONS.	162
A-3	AUTHORED PUBLICATIONS.....	164
APPENDIX B GLOSSARY		165
B-1	DEFINITIONS.....	165
B-2	ABBREVIATIONS.	168
APPENDIX C HIGH MAST LIGHTING		171

FIGURES

Figure 2-1	Pier and Wharf Types.....	9
Figure 2-2	Wharf Types.....	10
Figure 2-3	Length and Width of Slip	19
Figure 2-4	Location of Crane Rails, Railroad Tracks, and Utilities	21
Figure 2-5	Single Deck Pier	25
Figure 2-6	Double Deck Pier.....	26
Figure 2-7	Open and Solid Type Piers/Wharves	39
Figure 2-8	Floating Double Deck Pier.....	40
Figure 2-9	Open Type Wharf Concepts	45
Figure 2-10	Closed Type Wharf Concepts	47
Figure 2-11	Solid Type, Cellular Construction.....	49
Figure 2-12	Solid Type, Caisson and Concrete Block Construction	51
Figure 3-1	AASHTO LRFD Design Truck and Design Tandem.....	55
Figure 3-2	Wheel Loads for Portal Cranes	57
Figure 3-3	Configuration and Wheel Loads for Container Cranes.....	58
Figure 3-4	Wheel Loads and Dimensions for Truck Cranes	60
Figure 3-5	Wheel Loads for Forklifts	63

Figure 3-6	Wheel Loads for Straddle Carriers	64
Figure 3-7	Principal Modes of Ice Action	74
Figure 4-1	Concrete Deck Construction.....	85
Figure 4-2	Cantilevered Precast Pile Cap.....	87
Figure 4-3	Conventional versus Gravity Prestressed Pile Caps	88
Figure 4-4	Tabletop Pile Cap Variations.....	89
Figure 4-5	Substructure Framing Concepts	90
Figure 4-6	Mooring Dolphins.....	95
Figure 4-7	Railroad Track Support.....	97
Figure 4-8	Crane Rail Support.....	98
Figure 4-9	Bullrail Details	99
Figure 4-10	Utility Trench Concept.....	100
Figure 4-11	Utility Hood	101
Figure 5-1	Energy Model of a Fender System.....	104
Figure 5-2	Eccentricity Coefficient, C_e	108
Figure 5-3	Berthing Velocity for Small Ships (up to 20,000 tons)	110
Figure 5-4	Berthing Velocity for Large Ship	111
Figure 5-5	Foam-filled Fender System	114
Figure 5-6	Fiberglass Fender Pile System	115
Figure 5-7	Plastic Fender Pile System.....	116
Figure 5-8	Side-loaded and End-loaded Rubber Fenders.....	119
Figure 5-9	Shear Fender	120
Figure 5-10	Buckling Fender with Contact Panel	121
Figure 5-11	Pneumatic Fenders	123
Figure 5-12	Hydro-pneumatic Fender.....	124
Figure 5-13	Monopile Fender System.....	126
Figure 5-14	Evaluation of Fender System Types.....	131
Figure 5-15	Corner Protection.....	135
Figure 6-1	Deep Draft Camel (NAVFAC drawing 100400035)	139
Figure 6-2	Universal Composite Submarine Camel	140
Figure 6-3	Aircraft Carrier Camel.....	145
Figure 6-4	Universal Composite CVN Camel	147
Figure 7-1	Small Floating Stage.....	151
Figure 7-2	Transfer Bridge for LHAs	155
Figure 7-3	Safety Ladder at Protected Berth	157
Figure 7-4	Safety Ladder at Unprotected Berth	158

TABLES

Table 2-1	Ship Characteristics for Selected Ships (Fully Loaded).....	14
Table 2-2	Ship Characteristics for Selected Ships (Lightly Loaded)	15
Table 2-3	Typical Pier and Wharf Widths	22
Table 2-4	Estimated Space Requirements for PMA.....	30
Table 3-1	Unit Weights.....	53
Table 3-2	Vertical Live Loads for Pier and Wharf Decks.....	54
Table 3-3	Outrigger Float Loads for Mobile Cranes	61

Table 3-4 Seismic Design Classifications	69
Table 3-5 Values of C_s, Modifier for Short-Period Spectral Acceleration.....	70
Table 3-6 Values of C_1, Modifier for 1-Second Period Spectral Acceleration.....	71
Table 3-7 Load Combinations - Load and Resistance Factor Design.....	77
Table 3-8 Load Combinations - Allowable Stress Design (ASD).....	77

This Page Intentionally Left Blank

CHAPTER 1 INTRODUCTION

V1\

1-1 PURPOSE AND SCOPE.

This UFC contains descriptions and design criteria for pier and wharf construction, including subsidiary, contiguous, and auxiliary structures. Loading details, regulations, furnishings, appurtenances, and other information are discussed when applicable. This UFC provides minimum facility planning and design criteria for efficient homeporting facilities of DoD vessels. Existing ports, facilities, and berths may not meet all criteria and may therefore, perform less efficiently, but do not necessarily require upgrade. This UFC focuses on the entire homeport operation. For example, ships will visit fueling and ammunition piers for short periods, but generally berth at general purpose berthing piers.

[C] 1-1 Triggers requiring an entire upgrade or replacement are under consideration for future revisions to this document.

1-2 APPLICABILITY.

This UFC applies to the design and construction of new, renovated, and repaired waterfront facility projects for the Department of Defense (DoD). It is applicable to all methods of project delivery and levels of construction. However, existing structures may not be able to meet some of the requirements in this UFC, but do not necessarily need to be upgraded. Incorporate requirements as best as possible and operationally for existing structures. Requirements in this UFC may support the need to replace an inadequate facility.

1-3 GENERAL FUNCTION.

An important consideration that often comes up has to do with differentiation between homeports and ports of call. A homeport for a specific ship has been identified as such by Commander Fleet Forces Command and is listed in the Naval Vessel Register (<http://www.nvr.navy.mil>). The homeport is where the ship is assigned and offers all requisite services required by the ship to include the full complement of hotel services. In contrast, a port of call would be any port where a ship stops along the way other than its homeport, e.g.: a fueling pier, an ammunition pier, a supply pier, or a repair pier. The only real requirements for a port of call would be that it has sufficient dredge depth and that it provides secure mooring. A ship does not go cold iron in port of call and uses its organic systems. However, local determinations and justifications can warrant adding specific features at ports of call. Many of the new classes of ships have concepts of operations and special mission requirements that have resulted in making accommodations at ports in forward operating areas that ordinarily would not be required, i.e. hotel services. These are handled on a case-by-case basis and driven by operational requirements. Generally, piers and wharves provide:

- Berths with sufficient dredge depths for vessels.

- Secure mooring for vessels berths.
- Transfer points for cargo and/or passengers between water carriers and land transport.
- Facilities for repair; and specialized functions.

1-4 CATEGORIES.

Piers and wharves are categorized into four (4) primary facility types and sub-types as follows:

1-4.1 Type I – Fueling, Ammunition, and Supply.

1-4.1.1 Fueling.

These are dedicated piers and wharves equipped with facilities for off-loading fuel from ship to storage and for fueling ships from storage. For additional design criteria, see UFC 4-150-02, *Dockside Utilities for Ship Service*.

1-4.1.2 Ammunition.

These are dedicated piers and wharves used for discharging ammunition for storage and for loading ammunition on outgoing ships. Explosives and ammunition quantity/distance standards are discussed in NAVSEA OP 5, Volume 1, *Ammunition and Explosives Safety Ashore*.

1-4.1.3 Supply.

Supply piers and wharves are used primarily for the transfer of cargo between ships and shore facilities. Provide standard gage railroad tracks when supplies will be brought in by rail.

1-4.2 Type II – General Purpose.

1-4.2.1 Berthing.

General purpose berthing piers and wharves are used primarily for mooring ships. Furthermore, berthing facilities may be active, as when ships are berthed for relatively short times and are ready to put to sea on short notice, and inactive, as when they are berthed for long periods in a reserve status. Depending upon intended pier usage, i.e. active berthing, maintenance/repair, inactive berthing, consider appropriate mooring service type as it relates to design/capacity of mooring fixtures. Activities that typically take place on berthing piers and wharves are personnel transfer, maintenance, crew training, cargo transfer, and waste handling. Under some circumstances, fueling and weapons system testing may also be carried out in these facilities.

1-4.2.2 Type IIA – Hybrid General Purpose/Repair.

A Type IIA 'Hybrid' General Purpose/Repair pier or berth is a Type II General Purpose pier/berth with enhanced features, similar to a Type III Repair pier typically found at a shipyard. It can support more advanced ship maintenance and repairs at a non-shipyard installation, but is not fully Type III compliant. It may be:

- A dedicated Type III repair pier/berth at a DoD general berthing installation that may or may not be situated in an enclave.
- A Type II pier or berth that does not meet the full requirements of a Type III repair pier/berth, but has limited capabilities to perform ship maintenance and repair.
- Or a Type II pier with dedicated berths that meet requirements of a Type III repair pier.

[C] There is not a definitive definition of a Type IIA 'Hybrid' repair/berth. Each requirement, location, function, and situation must be evaluated and balanced with operations and risks considered to determine what level of ship maintenance and repair can be provided at a non-shipyard Type III facility. The cognizant ship operating command and shore installation will have to determine who is responsible and fund the ship requirements.

A Type IIA pier/berth must meet the Type II requirements of this UFC, UFC 4-150-02, NAVSEA 8010, other UFCs, and include, but not limited to, the following:

- Heavy Weather Moorings (HWM).
- Permeant or temporary utility services, including a dedicated shore-supplied saltwater or nonpotable water supply for ship firefighting.
- Dedicated fire lane(s).
- Suitable capacity for crane operations.

Risks to be evaluated by installations and maintenance and repair activities (i.e. NAVSEA, CNIC, NAVFAC, DoD, and non-DoD commands) include:

- Limited availability of utilities.
- Limited deck space and laydown areas.
- Limited access.
- Limited crane operations.
- Limited dredge depth, slip width, clearance.

See other portions of this UFC, UFC 4-150-02, UFC 4-159-03, other applicable waterfront and facilities UFCs, and NAVSEA documents.

Each installation and project must consider, evaluate, and accept the risks of designating a Type IIA or Type III repair pier/berth at a DoD installation. This includes private shipyards.

1-4.2.3 Non-DoD Berthing.

Non-DoD agencies may be a tenant command at DoD installations. They may utilize DoD waterfront and supporting facilities on a DoD installation or fund and build their own facilities. They must have a MOA on record showing the agreement between the agencies. It must include the responsible Government Agency, financial commitment, criteria commitment, operations and maintenance plan, and plan to turn over a facility to the DoD if the non-DoD agency leaves the DoD installation.

1-4.3 Type III – Repair.

An important consideration for repair piers is the need to provide heavy weather mooring capability. This includes properly sized and spaced storm bollards and a compliment of heavy weather mooring lines. This consideration is predicated upon the fact that ships under repair may not be able to get underway during a heavy weather event.

See Type IIA definition for considerations regarding a ‘Hybrid’ Type II General Purpose pier and a fully capable Type III Repair pier.

1-4.3.1 Repair.

Repair piers and wharves are constructed and equipped to permit overhaul of ships and portions of a hull above the waterline. These structures are generally equipped with portal cranes or designed to accommodate heavy mobile cranes.

1-4.3.2 Floating Dry Docks.

Piers and wharves for floating dry docks are constructed and equipped to permit overhaul of ships above and below the waterline. Some floating dry docks have portal cranes on tracks on the wingwalls and some floating dry docks use cranes from the pier side. Provide adequate dredge depth at these facilities to accommodate the floating dry dock when submerged. Floating dry docks are normally moored using two or more vertical spuds that maintain the horizontal position of the dock throughout its full range of vertical movement from fully submerged to fully dewatered. Design the pier/wharf structure to accommodate mooring spud placement and loading. The pier or wharf layout should also consider personnel, material, and vehicle access to the dry dock pontoon deck when the dry dock is in the raised (dewatered) position. In the design of a pier or wharf structure, consider variations of the floating dry dock in the unballasted, ballasted, and partially ballasted positions.

1-4.4 Type IV – Specialized.

1-4.4.1 Magnetic Treatment and Electromagnetic Roll Piers.

These are piers that moor ships over an array of underwater instruments and large-area cable solenoids used specifically for removing and/or modifying the magnetic signature characteristics of surface vessels and submarines, as well as calibrating the on-board degaussing systems of mine countermeasure vessels. Magnetic treatment facility designs vary using slips, T-piers, or single piers depending upon location and requirement. Magnetic treatment piers designed to accommodate surface vessels are typically configured as T-shapes; whereas, submarines and mine countermeasure vessels are typically treated at drive-in piers built in parallel configurations.

1-4.4.2 Training, Small Craft, and Specialized Vessels.

These piers and wharves are typically light structures designed for specific but limited functions. Specific requirements are usually provided by the activity. Additional guidance can be found in UFC 4-152-07, *Small Craft Berthing Facilities*.

1-5 FLEXIBILITY OF BERTHS.

Typically, piers and wharves are designed to provide space, utility service, and other supporting facilities for specific incoming or homeported ships. However, berthing plans and classes of ships berthed change with time. While it is not economically feasible to develop a single facility to accommodate and service all known ship classes, design the facility with a certain amount of built-in flexibility to allow for anticipated future changes in the functional requirements. This is especially true for berthing piers and wharves that will be used to accommodate different classes of ships as well as support a variety of new operations.

1-6 APPURTENANCES AND FEATURES.

The following is a range of appurtenances and features that may be required for piers and wharves.

- Mooring devices to safely secure the ship.
- Fender systems, camels and separators.
- Hotel and ship service utilities.
- Communications.
- Cranes and crane trackage.
- Access facilities for railroad cars and trucks.
- Waste handling facilities.
- Cargo handling equipment.
- Covered and open storage spaces for cargo.

- Support building, tool shed, office space, and control rooms.
- Lighting poles and equipment.
- Lightning protection.
- Security systems.
- Firefighting equipment.
- Emergency medical facilities.
- Access structures and facilities.
- Fueling facilities.
- Safety ladders.
- Life-safety rings.

1-7 GENERAL BUILDING REQUIREMENTS.

Comply with UFC 1-200-01, *DoD Building Code*. UFC 1-200-01 provides applicability of model building codes and government unique criteria for typical design disciplines and building systems, as well as for accessibility, antiterrorism, security, high performance and sustainability requirements, and safety. Use this UFC in addition to UFC 1-200-01 and the UFCs and government criteria referenced therein.

1-8 GLOSSARY.

APPENDIX B contains acronyms, abbreviations, and terms.

1-9 REFERENCES.

APPENDIX A contains a list of references used in this document. The publication date of the code or standard is not included in this document. Unless otherwise specified, the most recent edition of the referenced publication applies.

/1/

CHAPTER 2 FACILITY PLANNING

2-1 LOCATION AND ORIENTATION.

2-1.1 General.

The location and alignment of piers and wharves in a harbor should consider factors such as:

- Maneuverability.
- Required quayage.
- Harbor line restrictions.
- Geotechnical conditions.
- Isolation requirements.
- Prevailing wind and current directions.
- Wave climate.
- Sea level change.
- Clearance between moored or passing vessels.
- Project depth.
- Shoaling patterns.
- Environmental permit restrictions.
- Port regulations.
- Landside access/proximity.
- Shoreside elements required as part of a pier/wharf project.
- Proximity to commercial and military airfields (potential restriction to crane operations).

For further discussion and criteria, see UFC 4-150-06, *Military Harbors and Coastal Facilities*.

2-1.2 Orientation for Environmental Conditions.

To the extent practical, orient piers and wharves so that a moored ship is headed into the direction of the prevailing winds and currents. Thus, the forces induced on mooring lines by these conditions would be kept to a minimum. If such an arrangement is not feasible, consider an orientation in which the wind or current holds the ship off the facility, although do not overlook the difficulty in mooring a ship under such conditions. In locations where criteria for both wind and current cannot be met, orient the berth parallel to the direction of the more severe condition. At locations exposed to waves and swell, locate the facility so that a moored ship is headed into the wave or swell

front. If planning criteria dictate that a pier or wharf be oriented so that a moored ship is positioned broadside to the prevailing winds, currents, or waves, consider breast-off buoys to keep the ship off the facility and diminish the possibility of damage to the structure and ship. At oil storage terminals located in areas where meteorological and hydrological conditions are severe, consider using a single point mooring which allows a moored tanker to swing freely when acted upon by winds, waves, and currents from varying directions. See UFC 4-159-03, *Moorings*.

2-1.2.1 Pier Orientation.

A pier is oriented either perpendicular to or at an angle with the shore. There are generally ships on both sides, although there are instances where only one side has a ship because of site conditions or because there is no need for additional berthing. Piers may be more desirable than wharves when there is limited space available because both sides of a pier may be used for mooring ships. When both sides of a moored ship need to be accessed, two parallel piers with a slip in between may be preferred. Magnetic Treatment and Electromagnetic Roll piers usually require a magnetic north/south orientation, irrespective of other considerations.

2-1.2.2 Wharf Orientation.

A wharf is a structure oriented approximately parallel to the shore. Ships can only be moored at the offshore face of a wharf. When water depths close to shore are not adequate to accommodate deep draft ships, the wharf, consisting of a platform on piles, is located offshore in deep water and is connected to shore at one or more points by pile-supported trestles, usually at right angles to the wharf. If the trestle is located at the center of the wharf, the structure is referred to as a T-type wharf; if the trestle is located at an end, the facility is known as an L-type wharf; if trestles are located at both ends, the wharf is called a U-type wharf. Ships may be berthed on both sides of a T- or L-wharf. When the offshore wharf is used for transfer of bulk liquid cargo from the unloading platform to shore via submarine pipelines, the structure is referred to as an island wharf. A trestle from the offshore wharf to shore is not provided and both sides of the island wharf may be used for mooring ships. Launches are used for wharf access. Where a U-shaped berth is formed by a cut into land by two approximately parallel wharves, this may be referred to as a slip. For examples of pier and wharf types, see Figures 2-1 and 2-2. For general cargo, supply, and container terminals, a wharf structure, connected to upland shore area for its full length, is preferred because such an arrangement is more adaptable to loop rail and highway connections and the distance from wharf apron to transit sheds and open storage areas is shorter.

2-1.3 Vessel Ingress and Egress.

On occasion, a moored vessel is required to make a hasty departure from its berth and head out to sea. Accordingly, when planning a pier or wharf, consider providing adequate turning area so that a ship can be turned before it is docked, and moored with a heading that will permit a convenient and rapid departure.

Figure 2-1 Pier and Wharf Types

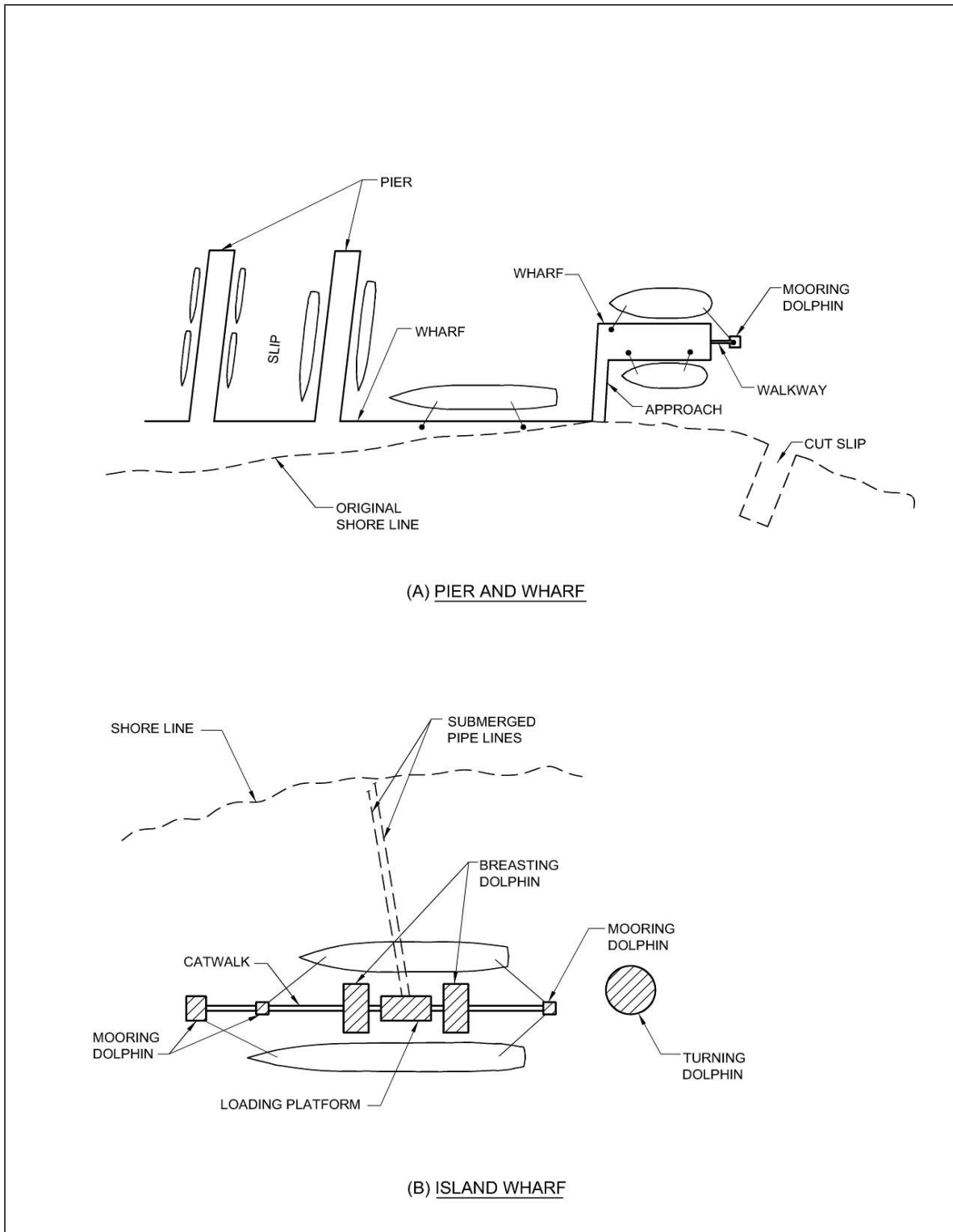
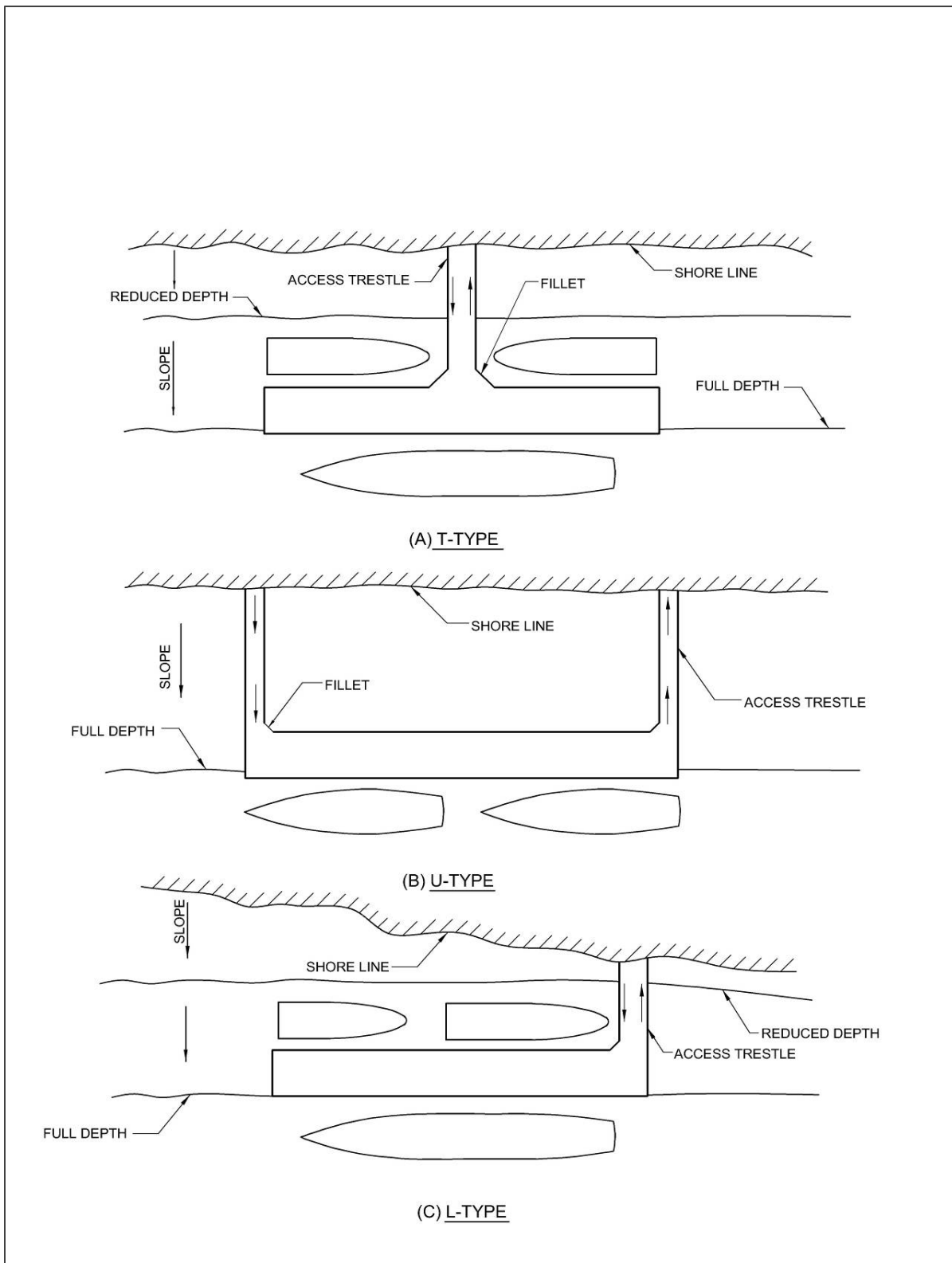

Figure 2-2 Wharf Types



2-1.3.1 Disaster Control and Emergency Plans.

In an emergency, tugs may not be available. Therefore, the slip, berth, basin, and channels should allow the ship to get underway without assistance. See OPNAVINST 3040.5D, *Procedures and Operations Reporting Requirements for Nuclear Reactor and Radiological Accidents*. There will be cases where a ship will not be able to leave prior to heavy weather (such as during a Phased Maintenance Activity (PMA) or Planned Incremental Availability (PIA) for CVN). General-purpose berths are designed for Mooring Service Type IIB. Repair berths are designed for Mooring Service Type III. See the heavy weather mooring criteria contained in UFC 4-159-03, *Design: Moorings*.

Design facility systems for continuous operation in the event of a power outage, in other words, pier/wharf remains operational with exception of having shore power and lighting.

2-1.3.2 Harbor Elements.

Information on channel approaches (outer channels), entrances (inner channels), and turning basins to include recommended widths and depths is contained in UFC 4-150-06, *Military Harbors and Coastal Facilities*.

2-1.4 Water Depth.

Consider a wharf structure at locations where the required depth of water is available close to shore and the harbor bottom slopes steeply out to deeper water. At locations where water depths are shallow and extensive dredging would be required to provide the required depth of water close to shore, consider locating the facility offshore, in deeper water, by utilizing a T-, L-, or U-type wharf.

2-1.5 Dolphins.

These are small independent platforms or groups of piles used by themselves or in conjunction with a pier or wharf for specialized purposes. A mooring dolphin is sometimes used at the offshore end of a pier or both ends of a wharf to tie up the bow or stern lines of a ship at a more favorable angle. Mooring dolphins are usually accessed by a catwalk, as illustrated in Figure 2-1, and are provided with a bollard or capstan. Breasting dolphins are sometimes used for roll-on/roll-off facilities and at fueling terminals where a full-length pier or wharf is not required. They may also be used as part of the fender system. A turning dolphin is an isolated structure used solely for guiding the ships into a berth or away from known obstructions. Occasionally, a mooring dolphin may also be designed to function as a turning dolphin. Approach dolphins are used where the end of a pier or ends of a slip require protection from incoming ships. Breasting, berthing and turning dolphins are normally designed as semi-flexible structures with full utilization of their energy absorption capacity within elastic range, while mooring dolphins are normally designed as rigid systems.

2-2 COORDINATION OF REPAIR.

2-2.1 General.

Ships will undergo a Phase Maintenance Program based on the Class Maintenance Plan (CMP). These maintenance activities will generally be conducted at a repair berth. Ships in dry dock and in inactive status require specialized criteria that NAVFAC will provide as requested. Coordinate capability of local ship repair facilities and salvage operations with NAVSEA SUPSHIP. The following facilities should be available within a reasonable distance from the support facility homeport.

- a. A Ship Maintenance Facility (SMF) housing the machine tools, industrial processes and work functions necessary to perform non-radiological depot level maintenance on ship propulsion plants.
- b. A Maintenance Support Facility (MSF) housing both administrative and technical staff offices supporting ship propulsion plant maintenance, as well as central area for receiving, inspecting, shipping, and storing hazardous/mixed waste materials and maintenance materials, and controlled radiological tank storage.
- c. A Controlled Industrial Facility (CIF) or Radiological Work Facility used for the inspection, modification, and repair of radiological controlled equipment and components associated with Naval nuclear propulsion plants. It also provides facilities and equipment for the treatment, reclamation, and packaging for disposal of radiologically controlled liquids and solids. It includes non-radiologically controlled spaces for administration and other support functions.
- d. Dry dock facilities for various classes of ships. Refer to UFC 4-213-12, *Dry Docking Facilities Characteristics* for listing and details on active U.S. Navy graving dry docks. Consult with NAVSEA and the ship's Maintenance Program Master Plan and Class Master Plan (CMP) for specific requirements. Few floating dry docks remain active as service craft in the U.S. Navy inventory. Special moorings may be required for floating dry docks and special consideration for dredging (and shoaling) to allow for lowering of the dock is required.
- e. Phased Maintenance Activities (PMA). PMA is a short, labor-intensive availability for ships in a Phased Maintenance Program for the accomplishment of maintenance and modernization. At some Naval stations, PMA is performed at general purpose berthing piers. PMA is discussed in detail in a subsequent section.

2-2.1.1 Aircraft Carriers.

Every 18 months an aircraft carrier will undergo a 6-month "Planned Incremental Availability (PIA)" at the repair berth. For CVN's, also coordinate with NAVSEA PMS 312 and NAVSEA 08, COMNAVAIRLANT N4, or COMNAVAIRPAC N4. Dry dock facilities for CVNs exist only at Puget Sound Naval Shipyard (PSNS), Norfolk Naval

Shipyard (NNSY), and Newport News Shipbuilding. NAVSEA 08 defines emergency dry dock facilities for CVNs. CVNs will be located at these facilities when this service is required.

2-3 OVERALL DIMENSIONS AND CLEARANCES.

2-3.1 General.

The overall dimensions and clearances required for piers and wharves are dependent on characteristics of the ships to be berthed and the support services provided. Comprehensive information on all U.S. Navy ships is found in the following locations or by contacting NAVFAC Atlantic - Engineering Criteria & Programs:

- Naval Vessel Register (NVR) (<http://www.nvr.navy.mil/nvrships/index.htm>). Note also that NVR provides a good reference regarding hull classification symbols, e.g. CVN = Multi-purpose aircraft carrier (nuclear propulsion)
- Military Sealift Command (MSC) (<http://www.msc.navy.mil/inventory>)

\\ Other Navy ship information can be found in a ship's Facility Planning Criteria (FPC). Contact other Services and Agencies for ship specific information on their ships.

2-3.1.1 Ship Characteristics.

Ship characteristics are provided in Tables 2-1 and 2-2. Data in tables is for various ship classes and is not all inclusive. There are many variants, blocks, and flights within a ship class. Designer is responsible for verifying information is correct and accurate for the ship(s) that will be berthed. //

V11

Table 2-1 Ship Characteristics for Selected Ships (Fully Loaded)

Ship Class	LOA	LWL	LBP	D ^{b, c}	M	B	A _y	A _x	h _h	h _s
CVN 68 ^a	1115.0	1056.0	1040.0	40.2	91490.0	134.0	79450.0	14750.0	70.8	117.0
CVN 78 ^d	1092.0	1040.0	1040.0	TBD	TBD	134.0	TBD	TBD	TBD	TBD
CG 47 ^e	568.0	530.0	530.0	34.1 ^c	9407.0	55.0	24995.0	5330.0	28.8	80.4
DDG 51 ^a	505.0	466.0	466.0	33.6	8276.0	58.3	19130.0	4538.0	22.4	64.0
DDG 1000 ^a	607.0	600.0	600.0	28.6	14062.2	79.7	17098.6	1215.9	29.3	93.6
LCS 1 ^d	378.0 ^c	324.0	324.0	14.1	3292.0	57.0	TBD	TBD	TBD	TBD
LCS 2 ^a	418.6	388.9	390.0	14.2	3138.0	99.9	16721.0	5180.0	31.2	101.3
JHSV ^a	337.9	311.1	311.0	12.8	2461.0	93.5	16146.0	4931.0	42.9	68.7
LCC 19 ^e	620.0	580.0	580.0	31.8	18972.0	108.0	34350.0	6950.0	44.0	90.0
LHA 1 ^e	820.0	765.0	765.0	28.7	39251.0	106.0	71250.0	10750.0	74.5	111.0
LHD 1 ^a	840.0	788.0	778.0	28.1	40674.0	106.0	61075.0	8800.0	65.1	137.0
LHD 8 ^d	847.0	778.0	778.0	29.1	41684.0	106.0	TBD	TBD	TBD	TBD
LPD 4 ^a	570.0	557.0	548.0	23.2	16420.0	84.0	31100.0	7700.0	36.0	69.0
LPD 17 ^a	684.0	661.0	657.8	23.4	23880.0	96.7	43057.0	9460.0	36.2	77.2
LSD 41 ^a	612.0	580.0	580.0	21.4	16481.0	84.0	34350.0	7100.0	41.9	92.8
MCM 1 ^e	224.0	212.9	212.9	15.2	1261.0	39.0	5400.0	1520.0	11.9	45.0
SSN 21 ^a	361.0	319.0	352.8	37.8 ^f	8144.0	30.3	2383.0	236.0	7.0	24.9
SSN 23 ^d	453.0 ^c	453.0	453.0	41.3 ^f	12130.0	40.0	TBD	TBD	TBD	TBD
SSN 688 ^a	362.0	341.0	TBD	33.2 ^f	6132.0	32.1	2194.0	104.0	5.9	23.4
SSN 774 ^a	377.0	355.0	377.0	33.8 ^f	6958.0	24.0	2050.0	200.0	4.8	22.9
SSBN 726 ^a	559.3	526.1	TBD	37.5 ^f	16871.0	30.0	4158.0	505.0	6.3	12.0
SSGN 726 ^a	559.3	526.1	TBD	37.9 ^f	16871.0	30.0	4158.0	505.0	6.3	12.0
PC 1 ^d	178.0	178.0	178.0	8.0	334.0	TBD	TBD	TBD	TBD	TBD
T-AGER 2 ^e	177.0	171.0	171.0	10.0	945.0	32.0	2800.0	830.0	TBD	TBD
T-AGOS 19 ^e	234.5	190.0	190.0	24.8	3408.0	80.1	TBD	TBD	23.9	41.9
T-AGS 60 ^e	329.0	310.0	310.0	19.0	5137.0	57.0	TBD	517.0	9.0	37.0
T-AH 19 ^a	894.0	855.0	855.0	32.8	69522.0	105.8	56830.0	9265.0	44.7	114.7
T-AKE 1 ^d	689.0	654.0	654.0	31.8	42528.0	106.0	TBD	TBD	TBD	TBD
T-AO 187 ^d	677.0	650.0	650.0	36.0	40700.0	97.0	TBD	TBD	TBD	TBD
T-ARS 50 ^d	255.0	240.0	240.0	16.9	3181.0	51.0	TBD	TBD	TBD	TBD
T-AS 39 ^d	644.0	620.0	620.0	31.5	22978.0	85.0	TBD	TBD	TBD	TBD
T-ATF 166 ^d	226.0	204.0	204.0	15.6	2000.0	42.0	TBD	TBD	TBD	TBD

Table 2-2 Ship Characteristics for Selected Ships (Lightly Loaded)

Ship Class	LOA	LWL	LBP	D ^b	M	B	A _y	A _x	h _h	h _s
CVN 68 ^a	1115.0	1056.0	1040.0	31.2	70920.0	134.0	86550.0	15650.0	71.6	124.0
CVN 78	TBD	TBD	TBD	TBD	TBD	TBD	TBD	TBD	TBD	TBD
CG 47 ^e	568.0	532.0 ^{e, g}	530.0	20.0 ^{e, g}	7392.0	55.0	26685.0 ^{e, g}	5435.0 ^{e, g}	31.8 ^{e, g}	83.6 ^{e, g}
DDG 51 ^a	505.0	464.7	466.0	17.7	6513.0	57.0	20340.0	4688.0	25.0	66.6
DDG 1000 ^{a, g}	607.0 ^a	588.2	600.0 ^a	20.9	13695.1	79.7	17098.6	1215.9	29.3	93.6
LCS 1 ^g	378.0	324.0	324.0	TBD	2707.0	57.0	TBD	TBD	TBD	TBD
LCS 2 ^a	418.6	393.4	390.0	9.9	2181.0	99.5	18579.0	5382.0	36.0	106.1
JHSV ^a	337.9	313.0	311.0	8.5	1575.0	93.5	17493.0	5094.0	47.2	73.0
LCC 19 ^e	620.0	580.0	580.0	24.0	12315.0	108.0	37250.0	7360.0	TBD	TBD
LHA 1 ^e	820.0	765.0	765.0	18.9	25555.0	106.0	76750.0	11500.0	74.5	111.0
LHD 1 ^a	840.0	750.0	778.0	27.8	27839.0	100.0	66375.0	9475.0	67.0	140.0
LHD 8 ^d	847.0	778.0	778.0	TBD	28176.0	106.0	TBD	TBD	TBD	TBD
LPD 4 ^a	570.0	557.0	548.0	14.5	9179.0	84.0	35450.0	8350.0	44.0	78.0
LPD 17 ^a	684.0	656.0	657.8	TBD	19208.0 ^d	TBD	46202.0	9930.0	41.0	82.0
LSD 41 ^a	612.0	580.0	580.0	18.5	11414.0	84.0	35029.0	7200.0	43.1	94.0
MCM 1 ^e	224.0	212.9	212.9 ^d	TBD	1161.0	39.0	TBD	TBD	TBD	TBD
SSN 21 ^a	361.0	319.0	352.8	TBD	7568.0 ^d	30.3	TBD	TBD	TBD	TBD
SSN 23	TBD	TBD	TBD	TBD	TBD	TBD	TBD	TBD	TBD	TBD
SSN 688 ^a	362.0	341.0	TBD	TBD	5700.0 ^d	32.1	TBD	TBD	TBD	TBD
SSN 774 ^a	377.0	355.0	377.0	TBD	6454.0 ^d	24.0	2050.0	200.0	4.8	22.9
SSBN 726 ^a	559.3	526.1	TBD	TBD	15275.0 ^d	30.0	TBD	TBD	TBD	TBD
SSGN 726 ^a	559.3	526.1	TBD	TBD	15275.0 ^d	30.0	TBD	TBD	TBD	TBD
PC 1 ^g	178.0	178.0	178.0	8.0	288.0	TBD	TBD	TBD	TBD	TBD
T-AGER 2 ^e	177.0	171.0	171.0	7.0	610.0	32.0	3350.0	920.0	TBD	TBD
T-AGOS 19 ^e	234.5	190.0	190.0	14.8	2610.0	79.5	TBD	TBD	33.9	51.9
T-AGS 60 ^e	329.0	310.0	310.0	12.9	2970.0	57.0	TBD	870.0	15.1	43.1
T-AH 19 ^a	894.0	855.0	855.0	32.8 ^c	24946.0	105.8	75040.0	11460.0	65.3	135.3
T-AKE 1	TBD	TBD	TBD	TBD	TBD	TBD	TBD	TBD	TBD	TBD
T-AO 187	TBD	TBD	TBD	TBD	TBD	TBD	TBD	TBD	TBD	TBD
T-ARS 50	TBD	TBD	TBD	TBD	TBD	TBD	TBD	TBD	TBD	TBD
T-AS 39	TBD	TBD	TBD	TBD	TBD	TBD	TBD	TBD	TBD	TBD
T-ATF 166	TBD	TBD	TBD	TBD	TBD	TBD	TBD	TBD	TBD	TBD

SHIP CHARACTERISTICS TABLE NOTES AND LEGEND

Notes in column and row headers apply to all contents in that column or row unless otherwise noted in table.

^a FIXMOOR Database \1\ Database is no longer available /1/
^b Values correspond to brackish water
^c UFC 4-150-06, <i>Military Harbors and Coastal Facilities</i> , Table 5-3
^d http://www.nvr.navy.mil/nvrships/S_TYPE.HTM
^e Ships Characteristics Database (SCDB) \1\ Database is no longer available /1/
^f NAVSEA ltr ser 392T236/117 dtd 8 May 15
^g 1/3 Cargo Stores
LOA = Length overall, feet
LWL = Length at waterline, feet
LBP = Length between perpendiculars, feet; also = L
D = Static draft of vessel, feet
M = Displacement of vessel, long tons
B = Beam at waterline, feet (Note: Not maximum beam)
A _y = Longitudinal projected area of ship, square feet
A _x = Transverse projected area of ship, square feet
h _n = Average height of hull above waterline, feet
h _s = Average height of superstructure, feet. Use the lightly loaded height of 180 feet (54.9 m) above the waterline. This includes combined superstructure and all communications / antenna array supported by the superstructure. Governing vessel is the LPD 17. Use the lightly loaded height of 215 feet (65.5 m). above the waterline for CVN's.

2-3.1.2 Supporting Items.

- a. Provide fender/camel systems for the following arrangements:
 - Multiple/nested berths for CG, DDG, LCS (surface combatants). Note that LCS 1 may be nested and LCS 2 may not be nested.
 - Single berths for LHD, LHA, multiple berths for LPD, LSD (amphibious assault).
 - Single berths for T-AKE, T-AO, T-AOE, (auxiliary).
 - Single berths for CVNs. CR-NAVFAAC-EXWC-CIOFP-1316, Oct. 2013, *USS Gerald R. Ford (CVN 78) Operational In-Port Analysis including Berthing, Mooring and Officers Brow Placement* has determined that extended CVN camels are required at double deck piers for both CVN 68 and CVN 78 class vessels.
 - Multiple/nested berths for SSN, SSBN, SSGN.
 - Multiple/nested berths for MCM, PC.

- b. Aircraft require extensive support. Those requirements are not addressed herein.
- c. A minimum of 5 acres (20,234 m²) of laydown area in addition to pier/wharf space is desirable. The laydown area should be within 1/2 mile (0.8 km) of the pier or wharf.
- d. Brows and Platforms are usually placed at ship's designated entry/egress points to the main deck. For CVN, two 45-foot (14 m) brows are usually placed on the ship's #2 elevator and one 60-foot (18 m) brow placed between elevators #2 and #3 to the main deck. Brow design length will be based on camel design and resulting standoff distance. CR-NAVFAC-EXWC-CIOFP-1316, Oct. 2013, *USS Gerald R. Ford (CVN 78) Operational In-Port Analysis including Berthing, Mooring and Officers Brow Placement* provides specific guidance concerning officer's brow placement for CVN 78 class vessel. To further define the unique brow requirements for CVN 78 a comprehensive 3D lift plan has been developed to model the lifting sequence for both installing and removing the brow. Similarly a 70- by 5-foot (21 by 1.5 m) counterweighted aluminum truss brow has been developed. For additional information, contact NAVFAC Atlantic - Engineering Criteria & Programs.
- e. For criteria related to access to piers or wharves refer to: UFC 1-200-01, *DoD Building Code (General Building Requirements)*; *ABA Standards*; and Department of Defense Deputy Secretary of Defense Memorandum Subject: *Access for People with Disabilities*, October 31, 2008.
- f. Sideport loading ramp access is of primary concern to LHA 1, LHD 1, and LPD 17. For double deck piers special ramps are required to access sideport loading ramp. Refer to *Amphibious Warfare Ship to Pier Interface Study* which provides details on the access problem as well as recommended special ramps.
- g. Generally, design CVN berths to accommodate a variety of other classes of ships as well.
- h. Design general warehouse space to be accessible to large trucks and handling equipment.
- i. Do not permit pier interferences such as utilities and deck appurtenances in the zone of elevators for CVN (#1, #2, and #3), LHA, or LHD. At times these ships may have to move off of their normal berth bridge mark, i.e. move CVN offshore for ordnance load or move LHA/LHD toward bulkhead for stern gate ramp placement. Objective is to keep edge of pier free of obstructions.
- j. Provide parking for ship's government and privately owned vehicles in proximity to entrance to the pier or wharf.
- k. Provide sufficient security for ships on the pier. Consider minimally manned ships.
- l. Provide safety equipment.

- m. In the event that a building is required on a pier or wharf, give consideration to both wind and seismic loading in compliance with current, applicable codes and standards. Consider seismic mass of both structure and pier or wharf as well as interaction between structure and pier or wharf. For the building reference UFC 3-301-01, *Structural Engineering*. /1/

2-3.2 Pier and Wharf Length.

2-3.2.1 Single Berth.

The length of pier or wharf should equal the overall length of the largest ship to be accommodated, plus an allowance of 50 feet (15.2 m) at each end of the ship. For aircraft carriers (CVN), increase the allowance at each end of the vessel to 100 feet (30.5 m). Refer to Figure 2-3. Single berths are commonly used by LHA, LHD (amphibious assault ships), T-AKE, T-AO, T-AOE, (auxiliary), and CVNs. \1\ Other ships may berth in a single berth configuration or in multiple berth configuration with the same or a mixture of ship classes depending on pier/wharf and available berthing space. /1/

2-3.2.2 Multiple Berths.

The length of a pier or wharf should equal the total overall length of the largest ships simultaneously accommodated, plus clear distance allowances of 100 feet (30.5 m) between ships and 50 feet (15.2 m) beyond outermost moored ships. Refer to Figure 2-3. Multiple berths are commonly used by CG, DDG, LCS (surface combatants), SSN, SSBN, SSGN (submarines), MCM (mine warfare), and PC (patrol). \1\ See paragraph 2-3.2.4 for further requirements for submarines. /1/

2-3.2.3 Container and RO/RO Berths.

The length of berths used for container or RO/RO berths should account for the requirements of the container cranes or special ramps. Where shipboard ramps are used, provide adequate berth length to allow for efficient vehicle maneuvering.

2-3.2.4 Submarine Berths.

For most classes of submarines, a 50-foot (15.2 m) end distance to a quaywall or bulkhead is adequate. The nose-to-tail spacing for multiple berthing should also be a minimum of 50 feet (15.2 m). \1\ However, the nose-to-tail spacing and end distance at the stern of some submarines may require 100 feet (30.5 m) of clearance. Larger submarines such as the Ohio class (Trident, SSBN/SSGN) require 150 feet (45.7 m) or more nose-to-tail spacing and clearance to bulkhead or quay wall. /1/ Where explosive safety distance considerations require the use of fragmentation barriers, or specific separation distances, provide spacing adjusted per the requirements of NAVSEA OP-5, *Ammunition And Explosives Safety Ashore*.

11

Figure 2-3 Length and Width of Slip

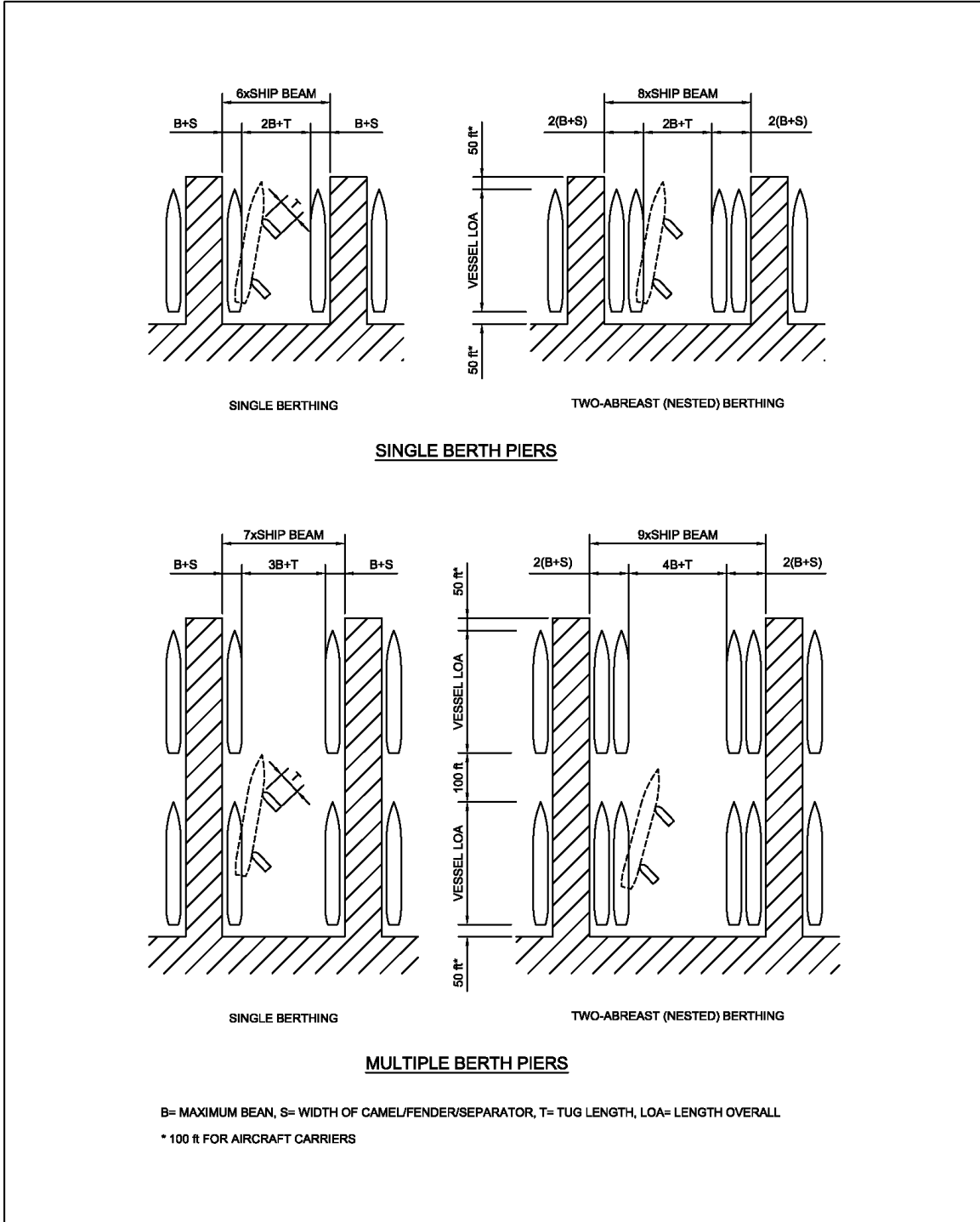

Note: Ship beam (B) is the extreme/maximum beam of the ship and not the beam at waterline.

11

2-3.2.5 CVN Berths.

CVNs are typically moored “starboard-side-to” to allow access to the ship’s elevators for loading/unloading.

2-3.3 Pier and Wharf Width.

1\ Pier width as used in this UFC refers to the edge to edge width of the structure, exclusive of fender systems. Refer to Figure 2-4. This definition also holds for U-, L-, and T-type wharves. However, with reference to wharves, the width is the dimension to a building, roadway, or other identifiable obstruction. Refer to Table 2-3 for minimum widths established for each functional type and ship. The dimensions in Table 2-3 are minimums for any pier or wharf constructed on a DoD installation and apply to all DoD and non-DoD tenant Commands. The pier and wharf widths must be followed unless a specific Memorandum of Agreement (MAO) is established and pier or wharf is completely funded and maintained by occupying tenant and facility will never be turned over to the DoD. Review with specific functional and operational requirements and physical constraints of the individual installation in mind before a final selection on width is made. /1/ Functional requirements include space for: cargo loading operations, line handling, ship maintenance, maintenance of utilities and layout of cables and hoses, solid waste collection, brows and platforms, crane operation, and other operations. For crane operation, consider crane outriggers, tail swing of crane counterweights, and overhang of vessels. For CVNs, coordinate the tail swing of gantry cranes with the overhang of the flight deck and elevators considering available camels and potential list of the ship. Also, these dimensions should not be less than the widths determined by geotechnical and structural considerations. Factors to be considered in the determination of pier and wharf width are discussed below.

Figure 2-4 Location of Crane Rails, Railroad Tracks, and Utilities

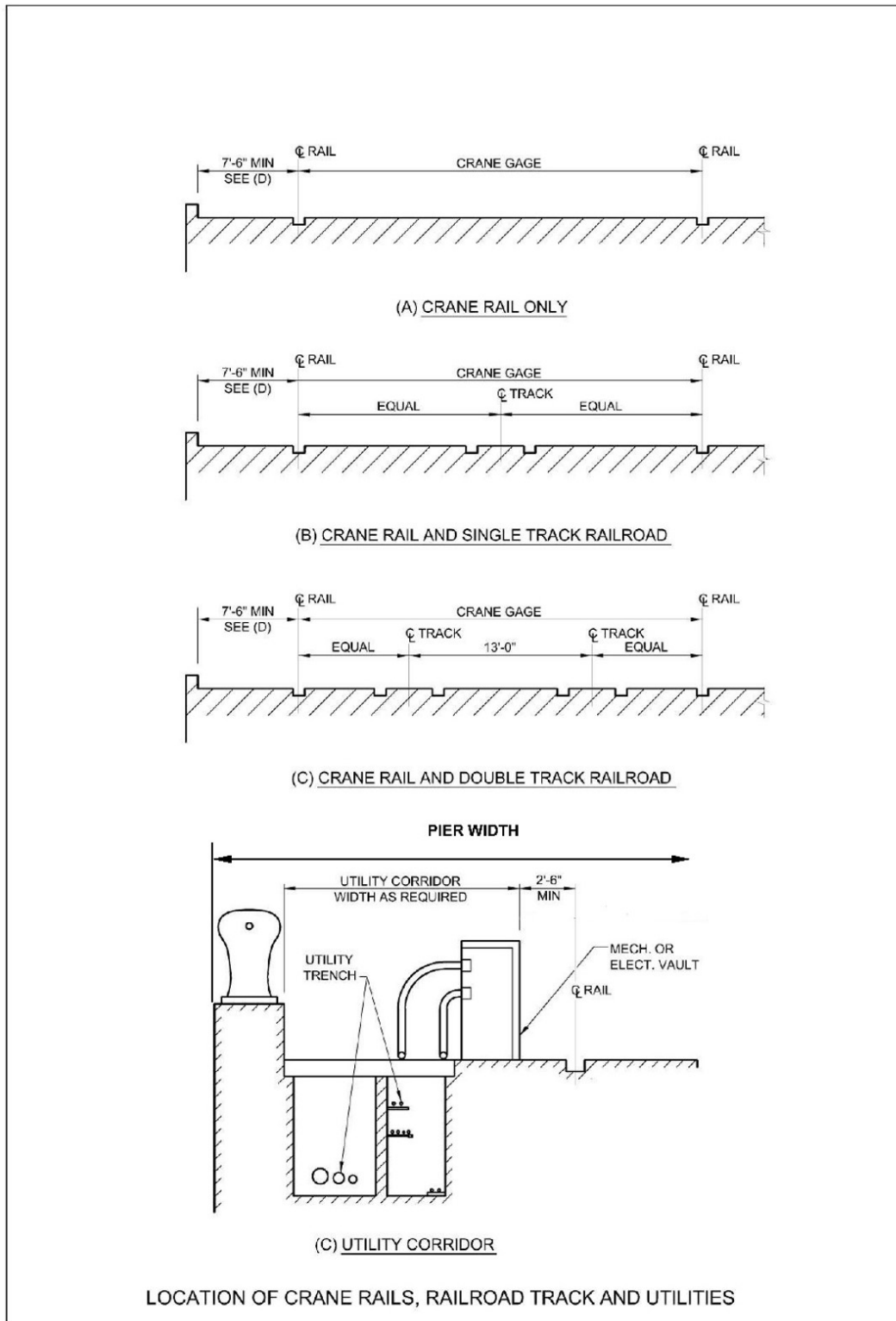

11

Table 2-3 Minimum Pier and Wharf Widths

Function Classification/Type	Ship Type	Typical Pier Width (feet)		Typical Wharf Apron Width (feet)	Railroad Track (Standard Gage)	Rail Mounted Cranes
		Single Deck Pier	Double Deck Pier			
Ammunition	Ammunition	100	-	100	-	-
General Purpose Berthing	Auxiliary	115	93	65	-	-
	Surface Warfare	115	93	65	-	-
	CVN	150	93	90	-	-
	Submarine ^a	65	-	65	-	-
	Submarine ^b	85	-	65	-	-
Repair (Type III)	Surface Warfare	125	-	75	4 tracks; 2 each side	(2) 40-ft gage; 1 each side
	CVN	150	-	100	-	-
	Submarine	100	-	100	-	-
Type IIA	* must meet minimum requirements for a Type III	*	*	*	-	-
Fueling	Auxiliary	50	40/50 ^c		-	-
Supply (General)	Auxiliary	125	-	100	2 tracks	-
Supply (Container)	Auxiliary	125	-	100	Up to 3 tracks	(1) 100-ft gage

Note:

- ^a Pier width is shown for a pier with only in-shore berths
- ^b Pier width is shown for a pier with in-shore and off-shore berths (multiple berths along its length)
- ^c Operational deck = 40 feet (12 m); utility deck = 50 feet (15 m)

11

2-3.3.1 Utilities.

One of the primary functions of a pier or wharf is to provide connections for utilities from ship to shore. Fixed utility terminals are usually provided close to the edge of the pier or wharf along the bullrail. Flexible hoses and cables are then connected to these terminals and to the ship. Depending upon the type of utility hoods, the terminals, hoses, and cables may require 10 to 15 feet (3 to 4.6 m) of space along the edge. Consider the types of utility hoods that require additional edge space for cable and hose laydown.

11 For single deck piers, locating substations off of the pier deck is preferable. However, on some single deck piers, substations need to be mounted on the deck due

to various constraints. This will take up approximately 25 feet (7.6 m) of pier width and may require a pier to be wider. If substations are mounted on the deck, locate them in areas that will minimize impacts on useable deck space and operations. Balance physical constraints with acceptable operational and local practices where necessary. /1/ Double deck piers are used to clear the operations deck of obstructions or where the width of the berth area is constrained by adjacent facilities or other limitations. This configuration allows the utility enclosures and the associated hoses, cables and maintenance activities to be segregated from the operational areas and allow crane operations closer to the edge of the pier or wharf.

2-3.3.2 Berths on One Side.

For general purpose berthing of surface ships at wharves or piers with berths only on one side, the typical width is 65 feet (19.8 m) comprised of: 15 feet (4.6 m) bollards and utilities, 30 feet (9.1 m) mobile crane ops, and 20 feet (6.1 m) fire lane. For CVNs with berth on one side, the typical width is 90 feet (27.4 m) comprised of: 20 feet (6.1 m) bollards and utilities, 30 feet (9.1 m) mobile crane ops, 20 feet (6.1 m) fire lane, and 20 feet (6.1 m) for loading area.

2-3.3.3 Berths on Both Sides.

For general purpose berthing of surface ships at a single deck pier with berths on both sides, the typical width is 115 feet (35 m) comprised of: 30 feet (9.1 m) bollards and utilities, 65 feet (19.8 m) mobile crane ops/loading area, and 20 feet (6.1 m) fire lane. A typical single deck pier is shown in Figure 2-5. For a single deck pier with CVNs (or combination CVN/AOE) berthed on both sides, the typical width is 150 feet (45.7 m) comprised of: 40 feet (12.2 m) bollards and utilities, 65 feet (19.8 m) mobile crane operations, 25 feet (7.6 m) loading area, and 20 feet (6.1 m) fire lane. This 150 feet (45.7 m) recommended width is based largely upon operational experience of existing facilities.

2-3.3.4 Double Deck Pier with Berths on Both Sides.

/1/ For double deck piers, typical width of top deck is 93 feet (28.3 m) comprised of: 8 feet bollards (2.4 m), 65 feet (19.8 m) mobile crane ops/loading area, and 20 feet (6.1 m) fire lane. A double deck pier provides: clear unobstructed pier to ship interface, isolation of operations deck services from lower deck utilities services (i.e. substation located on lower deck), reduced offset requirements for mobile crane operation (thereby reducing the requirement for floating cranes), higher main deck, improving mooring line angles and lessening need for brow platforms. A typical double deck pier is shown in Figure 2-6. /1/

2-3.3.5 Mobile Crane Operation.

With the exception of magnetic treatment/electromagnetic roll and fueling piers where a lighter duty mobile crane and/or forklift truck is sufficient, piers and wharves are subject to frequent usage by mobile cranes, forklifts, and straddle carriers. Typically, the cranes

will be used to lift light loads (5 to 10 tons) (44 kN to 89 kN) but at a longer reach. This requires a high-capacity crane. If the crane operations are not allowable because of utility trenches and trenches with light-duty covers, such areas should be clearly marked with striping or separated by a raised curb to prevent accidental usage. Typically, mobile crane operators want to get as close as possible to the edge of the pier or wharf to reduce the reach. However, the edges of piers and wharves are also the best places for locating utility trenches and utility trenches. This conflict can be resolved by either designing all utility covers to the high concentrated load from the mobile crane or by allowing crane operations in discrete and dedicated spaces along the edges. Weight-handling equipment requires maneuvering and turnaround space on the deck for effective operation. If possible the deck space should be planned to allow mobile cranes to be backed up perpendicular to the bullrail. This permits the maximum load/reach combination. Make allowance for tail-swing of crane counter-weight. Refer to Navy Crane Center Instruction 11450.2, *Design of Navy Shore Weight Handling Equipment*. The Navy Crane Center may also be consulted for operating requirements.

Figure 2-5 Single Deck Pier

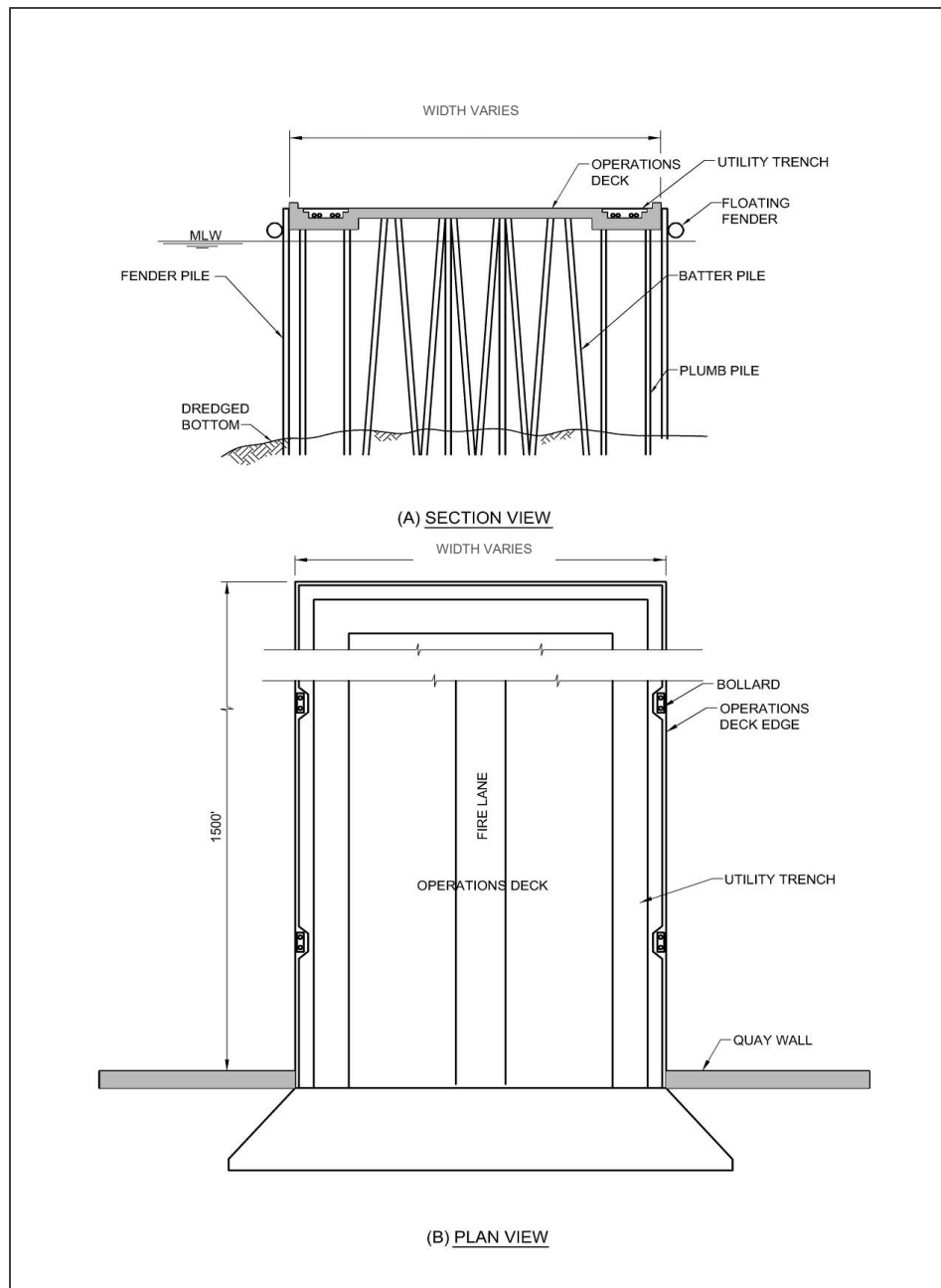
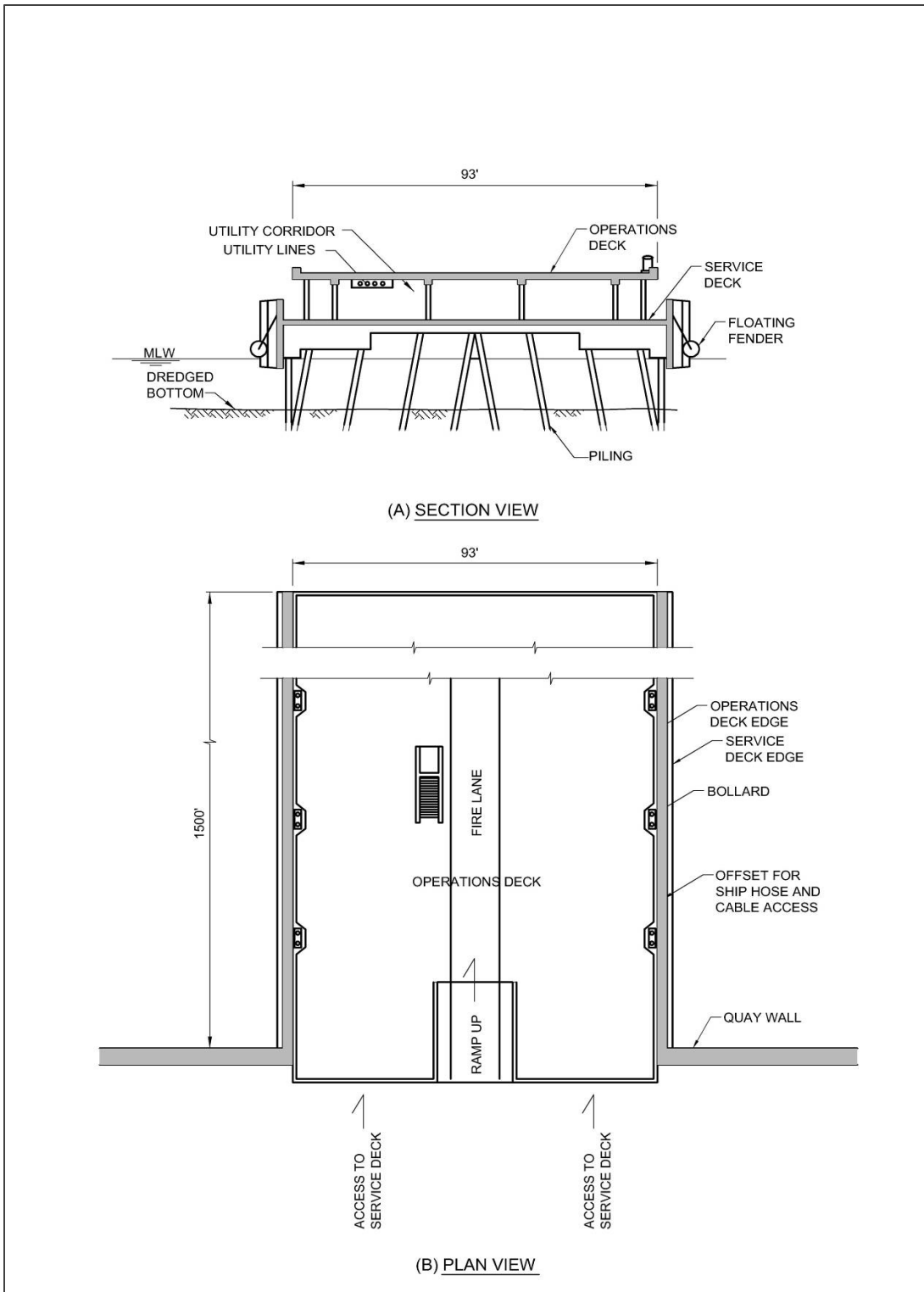

Figure 2-6 Double Deck Pier



2-3.3.6 Railroad and Crane Trackage.

The number of railroad and crane tracks required and type of weight-handling equipment furnished on piers and wharves are dependent on the type of function, ships to be accommodated, amount of cargo to be handled, and rate of cargo transfer. Specific service requirements of the individual installation should be evaluated in conjunction with the following considerations:

Rail mounted cranes are often needed for loadout in repair facilities. Width requirements depend on equipment selected. The use of wide gage crane service at repair, ammunition and supply piers, and wharves should be considered. Provide rail gage of 40 feet (12.2 m) (portal crane gage at PSNS and IMF Bremerton Site is 20 feet (6.1 m)) for new cranes, except at container terminals or where it is necessary to conform to gages of existing tracks. When cranes are furnished, the distance from the waterside crane rail to the edge of the pier or wharf should be adequate to provide clearance for bollards, cleats, capstans, pits housing outlets for ship services, crane power conductors, and other equipment. Some electric powered gantry cranes may require either open or covered (panzer-belts) cable trenches in the pier or wharf deck for the power conductors. Where locomotive cranes are used on piers and wharves, the distances between tracks and curbs should be increased to accommodate the tail swings of the crane. For discussion of crane power conductors, see Navy Crane Center Instruction 11450.2, *Design of Navy Shore Weight Handling Equipment*. For trackage requirements, UFC 4-860-03, *Railroad Track Maintenance and Safety Standards*.

In general, do not consider railroad trackage for use on berthing piers and wharves (active or inactive). In cases where stations receive most of their cargo by rail, consider one or more tracks for use on active berthing piers. When there are existing railroad networks at the station, tracks should be considered for installation on repair, ammunition and supply piers and wharves. When trackage is required along aprons of piers and wharves, at least two tracks should be provided so that one track may be used as a running track when the other track is occupied. Track gage should conform to gage of existing trackage on adjacent piers and wharves to avoid creation of "captive" cranes. Except where local conditions require otherwise, standard gage should be used for trackage. Width of piers and wharves should be adequate to allow passing of trains and forklift trucks (or other material-handling equipment). Make allowances for stored cargo and other obstructions.

Where sponsons or flight decks of CVNs or other ship types with large deck overhangs are anticipated to be berthed, locate the crane rail so that all parts of the crane will clear the deck overhang.

Railroad and crane trackage should not be considered for use on piers and wharves used primarily for fueling (petroleum) operations. When railroad and crane trackage is required on piers and wharves, the spacings shown on Figure 2-4 may be used as a guide.

2-3.3.7 Trucks and Other Vehicles.

A variety of service trucks and vehicles can be expected to use piers and wharves for moving personnel, cargo, containers, and supplies to and from the ships. Provide adequate width allowing for operation and maneuvering of such vehicles. Turnaround areas should be provided.

2-3.3.8 Sheds and Buildings.

Storage sheds and buildings of any kind should be kept off piers and wharves unless their location can be justified by operational or security considerations. Transit sheds may be considered on piers and wharves where a suitable upland area is not available. When used on a pier, the transit shed should be located along the centerline with clear aprons on both sides consistent with the requirements set forth herein but not less than 20 feet (6.1 m) or more wide. On wharves, transit sheds and support buildings should be located on the land side edge with a clear apron toward the waterside. In general, support buildings on piers and wharves should be kept as small as feasible and located away from high-activity areas for least interference.

2-3.3.9 Movable Containers and Trailers.

During active berthing of ships, various containers of different sizes are temporarily or permanently located on pier deck to support the operations. These include shipyard toolboxes, garbage dumpsters, training trailers, and supply trucks. Adequate deck space should be available for locating and accessing these containers and trailers.

2-3.3.10 Fire Lane.

Retain and mark, with a painted yellow line, a 15-foot-wide (4.6 m) unobstructed fire lane. Provide a marked (with dashed, painted yellow lines) 2.5-foot wide (0.8 m) “dual use” buffer on both sides of the 15-foot-wide (4.6 m) unobstructed fire lane. Examples are shown in Figure 2-X. Local enforcement would keep this area clear enabling a total available fire lane width of 20 feet (6.1 m). However, encroachment into the “dual use” buffer by cranes is acceptable. Any other encroachment into the “dual use” buffer will be handled on a case-by-case basis. For wharves, provide a 20-foot-wide (6.1 m) unobstructed fire lane immediately adjacent to the operating area. These requirements need not be applied to small craft or yard craft piers.

Retain and mark temporary traffic lanes including vehicular and pedestrian movements that may encroach upon the unobstructed fire lane. Parking, storage, and staging is not allowed within a fire lane. Mark fire lane with:

FIRE LANE DO NOT BLOCK

This includes bright yellow letters 12 inches (0.3 m) tall and 4 inch (102 mm) font spaced at 50 ft intervals.

On existing piers and wharves, mark fire lanes as close as possible to these requirements. It is understood that existing structures cannot meet these requirements due to construction and layout.

In some cases a crane may need to encroach or set up within a fire lane. In such cases, local crane operations must notify the local fire department and develop a safety plan include setting up a marked temporary fire lane.

[C] The following background is necessary to understand the reasoning for the current fire lane width specified for piers. Previous criteria called for a 12 ft (3.7 m) fire lane which was later increased to 15 ft (4.6 m), allowing for one-way traffic and some adjacent working area.

Later, an NFPA requirement calling for 20 ft (6.1 m) fire lanes was identified. Though it does not specifically apply to DoD piers, it was decided that it was a best practice and would be incorporated as a requirement with some stipulations. The current philosophy is supported by the fact that there are a number of considerations that go into development of pier width and pier area. Provide width and area for the following functions in addition to fire protection: berthing, maintenance, crew training, cargo transfer, light repair work, waste handling, fueling/ordnance handling (under some circumstances) and utilities that provide hotel services. Increasing pier width, by another 5 feet (1.5 m), over the length of the pier would cause a significant increase in construction cost and require additional real estate where multiple piers are arranged. Recognizing the fact that area is allotted for crane location along the length of the pier, this area will not be occupied a majority of the time, therefore, it is anticipated that additional area besides the 15 ft (4.6 m) fire lane and 2.5 ft (0.8 m) wide "dual use" buffer will be available along the pier for additional staging in the event of an emergency.

/1/

2-3.3.11 Fuel-Handling Equipment.

At specified berths, stationary fuel-handling equipment consisting of self-adjusting loading arms is often furnished to offload fuel products from tankers to onshore storage facilities. Pier or wharf width requirements depend on equipment selected and facilities furnished.

2-3.3.12 Phased Maintenance Activities (PMA).

The four levels of PMA and their estimated space requirements are as follows and as detailed in Table 2-4. For additional information, see NCEL TM-5, *Advanced Pier Concepts, Users Data Package* and OPNAVINST 4700.7L, *Maintenance Policy for U.S. Navy Ships*.

- a. Intermediate Maintenance Availability (IMA). IMA consists of removal and repair of shipboard equipment performed by Regional Maintenance Center (RMC) personnel or tender forces, with a duration of approximately 30 days.

Gross deck requirements range from 2000 to 3000 square feet (185.5 to 287.8 m²) with work area dimensions varying from 30 by 65 feet (9.1 by 19.8 m) to 30 by 100 feet (9.1 by 30.5 m).

- b. **Planned Restricted Availability (PRA).** PRA consists of limited repairs of shipboard equipment and systems by contract forces under Supervisor of Shipbuilding and Repairs (SUPSHIP) control, with a duration of 30 to 60 days. Gross deck area requirements are about 10,800 square feet (1003.4 m²) or 35 by 310 feet (10.7 by 94.5 m).
- c. **Selected Restricted Availability (SRA).** SRA consists of expanded repairs and/or minor ship alterations to shipboard equipment and systems by SUPSHIP contract forces, with a duration of approximately 60 days. Gross deck area requirements are about 18,000 square feet (1672.3 m²) or 35 by 515 feet (10.7 by 157 m).
- d. **Regular Overhaul (ROH).** ROH consists of major repairs and ship alterations to shipboard equipment and systems by SUPSHIP contract forces, with a duration of six to eight months. Gross deck area requirements are about 24,000 square feet (2229.7 m²) or 35 by 690 feet (10.7 by 210.3 m). In addition, there would be a requirement for turnaround areas on deck and warehousing off the pier or wharf.

Table 2-4 Estimated Space Requirements for PMA

Activity	PRA (ft ²)	SRA (ft ²)	ROH (ft ²)
Command Area ^a			
Mobile Administration Building	-	2,800	5,600
Parking Area	250	250	500
Bicycle Racks	70	140	200
Subtotal	320	3,120	6,300
Operating Area			
Demineralizer	-	1,500	1,500
Bilge Water/Stripping Tank	-	400	400
Dumpsters	1,150	1,440	1,730
Portable Solid-State Generators	-	240	240
Air Compressors	290	290	290
Welding	1,500	1,500	1,500
Flammable Storage	150	600	600
Transportation Laydown	600	900	1,500
Crane Work	3,850	3,850	5,250
Offload Area (oils, fuels, etc.)	3,000	3,600	4,500
Potable Heads	-	70	70
Additional Brow	-	400	400
Subtotal	10,540	14,790	17,980
Total	10,860	17,980	24,280

^a For piers with ordnance handling berths, do not provide command area

2-3.4 Slip.

2-3.4.1 General Considerations.

The clear distance between piers, or slip width, should be adequate to permit the safe docking and undocking of the maximum size ships that are to be accommodated in the slip. The size of a slip should also permit the safe maneuvering and working of tugboats, barges, lighters, and floating cranes. At multiple berth piers, where ships are docked either one per berth, two abreast per berth, or more, sufficient clearance should be available to permit the docking and undocking of ships at the inboard berth without interfering with ships at the outboard berth. Because the size of a slip is affected by docking and undocking maneuvers, consideration should be given to the advice of local pilots who are familiar with the ships to be handled and with prevailing environmental conditions such as winds, waves, swells, and currents. Slip width is also influenced by

the size and location of camels/separators used between ship and structure and between ships. The width should be reviewed with specific functional requirements of the individual installation before a final determination is made.

2-3.4.2 Minimum Slip Length.

Slip length basically follows the same criteria provided previously under section 2-3.2.

2-3.4.3 Minimum Width of Slip for Active Berthing.

2-3.4.3.1 Minimum Slip Width.

Minimum slip width should be the greater of the two dimensions shown on Figure 2-3. Additionally, the width should not be less than 300 feet (91.4 m). Slip widths discussed in this section are applicable only if ships are turned outside the slip area. Refer to Tables 2-1 and 2-2 for the beam of typical ship types (Note: Beam (B) shown tables is the beam at waterline and not the extreme beam. Use the widest beam (extreme/maximum beam) to determine horizontal clearances and slip width both for single berth and nested configurations.

Location of homeport berthing facilities should allow nesting of DDG, CG, SSN, LCS 1, MCM, and PC class ships. Minimum slip width for surface combatant in a multiple berth, nested configuration is 600 feet (183 m). Minimum slip width for single amphibious warfare and combat logistic ship berths is 600 feet (183 m). Other typical berthing arrangements can be found in paragraph 2-3.1.2.

2-3.4.3.2 CVN Slips.

For CVN's, minimum width is 600 feet (183 m) with no other ships, 800 feet (244 m) with CVN on opposite berth. Add 100 feet (30.5 m) to width if other ships are berthed at the bow or stern of the CVN. Use the widest beam to determine horizontal clearances and slip width both for single berth and nested configurations. Note that the waterline beam for CVN 68-77 is 134 feet (40.8 m) and the width of the flight deck structure (with

antenna platforms, walkways, and portable flight deck sections removed) is 252 feet (76.8 m). Without removing these appurtenances, CVN 68 is 260 feet (79.2 m), CVN 76 is 280 feet (85.3 m), and CVN 78 is 256 feet (78 m) wide.

2-3.4.3.3 Submarines Slips.

At submarine slips, width requirements must consider fender system, camels, and separators, barges, and other items that will encroach (takeup, occupy, etc.) slip width or width should be increased two beam widths [need Port Ops and SUBFOR input to reduce four beam requirement to 2B or delete; appears to be a holdover from DM 25.1 when just XxB was used and before B+S was added] to account for camels and separators, to provide for ships' vulnerability if their safety is involved, to provide for special maneuvering requirements of other ships during berthing or passing, and to provide for special environmental conditions such as currents, waves, and winds. Use extreme beam of submarine including the width of the planes and any added appurtenances when determining slip width. Beam widths can vary between vessels in the same class, so verify beam width of ships to be berthed and use the widest.

2-3.4.3.4 Slip Width for Nested Ships.

When more than two abreast berthing (nesting) is employed, the width of slip should be increased by one ship beam for each additional ship added in order to maintain adequate clearances between moored ships during berthing and unberthing maneuvers. Thus, for three-abreast berthing on both sides of a slip, the slip width for single-berth piers would be equal to 10 times ship beam and the slip width for multiple-berth piers would be equal to 11 times ship beam. Slip width may also be increased by accounting for appropriate ship beam plus separator (B + S).

2-3.4.3.5 Berthing on One Side of Slip.

The requirements discussed above apply where ships are berthed on both sides of a slip. Where ships are berthed on only one side of a slip, the width may be reduced by one ship beam plus separator (B + S). See Figure 2-3.

2-3.4.4 Minimum Width of Slip for Inactive Berthing.

At slips containing inactive berths where ships are stored for long periods of time on inactive status in nests of two, three, or more, clear distances between moored ships and slip width may be reduced by one or two ship beams to reflect the reduction in the frequency of berthing maneuvers and the decrease in activities of small boats and floating equipment.

2-3.4.5 Water Depth in Slips.

Information on required water depth in slips and at berths is contained in UFC 4-150-06, *Military Harbors and Coastal Facilities*.

2-3.5 Pier and Wharf Deck Elevation.

Set deck elevation as high as possible for surface ship berthing and as low as possible for submarine berthing, based on the following considerations. When determining proper deck elevation, give due consideration to different vessels that will occupy berths. Interferences often occur with appurtenances that rise above actual deck elevation, e.g. cleats, bollards, utilities, igloos, turtlebacks, etc.

2-3.5.1 Overtopping.

To avoid overflow, deck elevations should be set at a distance above mean higher high water (MHHW) level equal to two thirds of the maximum wave height, if any, plus a freeboard of at least 3 feet (1 m). Bottom elevation of deck slab should be kept at least 1-foot (0.3 m) above extreme high water (EHW) level. Where deck elevation selected would result in pile caps or beams being submerged partially or fully, consideration should be given to protecting the reinforcing from corroding. Also, when establishing deck elevation, consider utility trenches as they must be kept dry in all circumstances. In establishing the deck elevation, consideration may be given to the combined effects of sea level change, extreme water levels, and wave effects. Also, the intended service life of the structure should be taken into consideration as it relates to sea level rise and setting deck elevation. In locations where portal crane trackage is required, consider tie in with landside and limitations on grade change between pier/wharf and landside.

2-3.5.2 Ship Freeboard.

Consider the varying conditions of ship freeboard in relation to the use of brows and the operation of loading equipment such as conveyors, cranes, loading arms, and other material handling-equipment. Consider maintaining appropriate mooring line angles. Fully loaded ships at mean lower low water (MLLW) level and lightly loaded ships at MHHW level should be considered for evaluating the operation of such equipment.

2-3.5.3 Utilities.

Deck elevations should be set high enough above MHHW levels to allow for adequate gradients in drainage piping as well as to prevent flooding of utilities/trenches that are located below the pier deck.

2-3.5.4 Deck Elevation for CVN Berths.

Ensure that deck elevation does not conflict with CVN elevators. When lowered, the lowest projection of the elevator is 9 feet (2.7 m) above the design water line for a CVN. Use properly designed camels and pier fendering to provide sufficient standoff to prevent interference with appurtenances located on edge of pier deck such as mooring fittings, utility connections, igloos, etc.

2-3.5.5 Adjacent Land.

If possible, set deck elevation as close as possible to grade of the adjacent land for smooth access of mobile cranes, service vehicles, personnel vehicles, and railroad. Ramps may be used to access the deck set higher or lower than adjacent land. A maximum gradient of 15 percent may be used for such ramps when railroad access is not provided. Consideration should be made to reduce grade to 6 to 8 percent, comparable to state DOT requirements, in cold regions where snow or ice can be a problem. Ramps for pedestrian access should have a gradient less than 12 horizontal to 1 vertical, with 5 feet (1.5 m) minimum landings for every 30 inches (0.76 m) of rise to conform to American with Disabilities Act (ADA) of 1990. Vertical curves should be large enough so that long wheelbase or long overhang vehicles do not or drag. Where track mounted cranes are specified, all the deck areas serviced by the crane should be kept at the same elevation.

2-4 UTILITIES.

2-4.1 General.

For design criteria of utilities on piers and wharves, refer to UFC 4-150-02, *Dockside Utilities for Ship Service*. Usually, utility connection points (hoods, vaults, or mounds) are located and spaced along the pier or wharf edge to be as close as possible to the ships' utility terminals in the assumed berthing position. The connection points should be planned and located to accommodate reasonable future changes in berthing plan or in the type of ships served. Typical hotel services are: potable water, non-potable/saltwater, collection, holding, and transfer (CHT), oily waste/waste oil (OWWO), compressed air, steam, telecommunications, and shore power. All utility lines should be kept where they can be conveniently accessed from above deck. Typical utility configurations on piers and wharves are described below.

2-4.1.1 Utility Trenches.

These are basically protected trenches running along the waterside edge of a pier or wharf accessed by removable covers from the top. Refer to Figure 2-5. On a pier, the lines can go along one edge all the way to the end and be "looped" to the other edge back to land. On a wharf, the lines can be supplied and returned through smaller lateral "trenches." Where the number and size of lines is large enough, a utility tunnel or gallery can be utilized with access from the top or side. Where a fuel line is provided, it should be kept in a separate trench for containment of leaks.

2-4.1.2 Double Deck Pier.

As shown in Figure 2-6, utility lines are isolated on the lower deck and can be easily accessed. The upper deck is thus clear of all utility lines and terminations and is free for operations. There are situations on double deck piers (due to physical space and structural limitations) where some utilities are hung from underneath the lower deck (i.e. OWWO, CHT, and electrical).

2-4.1.3 Ballasted Deck.

This concept consists of a sloping deck filled with 1.5 to 3 feet (0.8 to 0.9 m) of crushed rock ballast, which provides a convenient medium to bury the utility lines and crane or rail trackage. The ballast is topped with concrete or asphalt paving, which will provide a firm working surface for operations. The paving and ballast can be removed to access the utility lines. Concrete pavers have been used successfully for paving ballasted decks and provide improved access to utilities buried in the wharf ballast. Future changes in utilities and trackage can similarly be accommodated. Also, the ballast helps to distribute concentrated load to the deck slab, thus allowing heavier crane outrigger loads. Ballast on the deck not only helps to distribute concentrated load to the deck slab, but also reduces or eliminates impact.

2-4.1.4 Precast Utility.

Precast tabletop slab sections discussed in section: Tabletop Pile Caps can be used for the utility trenches. This concept consists of a reinforced concrete or prestressed concrete platform that is integrated into the deck diaphragm. It is a durable structural element that is ideal for designs that orient pile cap beams in the longitudinal direction by creating a path for utility lines that do not interfere with key structural components along the length of the pier. Cantilevered ends and supplemental prestress should be used so that the concrete faces exposed to seawater remain uncracked under handling loads during erection and under service loads. Tie beams may be required to transfer berthing and mooring loads to the table top sections. A key element to the performance of the precast tabletop sections for utilidors is to ensure that they are watertight. Further details for tabletop slab sections can be found in TR-NAVFAC-EXWC-CI-1413, *The Use of Prestressed Concrete for Corrosion Prevention in US Navy Piers*.

2-5 LIGHTING.

Pier lighting is needed for security, safety, and operations. Provide safety and operations pier lighting in accordance with UFC 3-530-01, *Interior and Exterior Lighting Systems and Controls* and as follows:

2-5.1 Topside Lighting.

Refer to UFC 3-530-01, *Interior and Exterior Lighting Systems and Controls*. Instances of failures of high mast lighting light ring assembly failures have been reported. Additional information is contained in Appendix C. It is imperative that a registered structural engineer review all contract documents (plans and specifications) and construction contract submittals specifically related to high mast light ring assemblies. This is to ensure that design of light ring assembly provides for safe lowering, raising, and locking/securing into position.

2-5.2 Lower Deck Lighting.

Refer to UFC 3-530-01, *Interior and Exterior Lighting Systems and Controls*.

2-5.3 Underdeck Lighting.

Refer to UFC 3-530-01, *Interior and Exterior Lighting Systems and Controls*.

2-6 SECURITY.

For waterfront security and anti-terrorism/force protection criteria, refer to UFC 4-025-01, *Security Engineering: Waterfront Security*.

2-7 LANDSIDE APPROACHES.

2-7.1 Function.

Approaches are required to provide access from shore to piers and wharves located offshore. Usually, the approach is oriented at right angles to the shoreline. Except in special situations, provide approaches consisting of open-type trestle structures that minimize impediments to water flow and disturbances to the characteristics and ecology of the shoreline. Consider the volume of traffic flow, circulation of traffic, existing roads on shore side, fire lane requirements, and interruption of service due to accidental collision damage when planning and designing the landside approach. As approaches are also used to route utilities to the pier or wharf, the width of approaches will be further influenced by the space requirements of the utility lines being carried. Vehicle and pedestrian approach can usually be combined on the same structure. Consider a separate pedestrian approach when a large number of personnel are anticipated to access the facility.

2-7.2 Roadway Width.

- a. Provide an approach roadway with a minimum width of 10 feet (3.1 m) curb to curb for one-lane vehicular traffic for infrequently accessed facilities (such as magnetic treatment / electromagnetic roll piers).
- b. Provide an approach with a minimum width of 15 feet (4.6 m) curb-to-curb for clear access of emergency vehicles for fueling piers and wharves.
- c. For all other functional types, provide a two-way 24-foot wide (7.3 m) curb-to-curb roadway. If two separate one-way approaches are provided, provide a minimum width of 12 feet (3.7 m) curb-to-curb. Notwithstanding, provide approaches with a width adequate to permit fast movement of all vehicles anticipated for use on the facility, including emergency vehicles and mobile cranes.

2-7.3 Walkway Width.

Provide a minimum clear width of 3 feet (1 m) for separate walkway structures. Where the walkway is attached to a vehicle traffic lane, provide a minimum width of 2.5 feet (0.8 m) clear, from curb to safety railing.

2-7.4 Roadway Deck Elevation.

The requirements for pier and wharf deck elevation are also applicable to the approaches. Where the adjacent land is higher or lower than pier or wharf, the approach can be sloped up or down to serve as a transition ramp. For approaches longer than 100 feet (30.5 m) limit the slope to 6 percent. For shorter approaches, limit the slope to 8 percent.

2-7.5 Number of Approaches.

2-7.5.1 One Approach.

For fueling and magnetic treatment/electromagnetic roll facilities, provide at least one single-lane approach structure, unless the facility is built as an island wharf or pier with access by watercraft.

2-7.5.2 Two Approaches.

- a. Where volumes of vehicular movements are large, provide at least two approaches to ensure continuous uninterrupted traffic flows from pier or wharf to shore. At multiple-berth facilities, consider approach structures at least every 500 feet (152 m).
- b. Where the width of the pier or wharf is not sufficient to permit turning of vehicles, provide two approaches. Thus, vehicular traffic may enter and leave the facility without having to turn around. Since it is easier for a truck to negotiate a left turn, design traffic patterns to favor left turns.

2-7.5.3 Railroad Access.

Where rail access is planned for either crane or railroad, a separate approach is not necessary. However, consider a separate walkway. Consider approach slope limit for crane or railroad.

2-7.6 Turning Room.

At the intersection of approach and piers and wharves, provide fillets or additional deck area at corners to allow for ease in executing turns. Where a one-lane approach roadway is provided as the only access, provide the pier or wharf with sufficient turnaround space on the facility so that outgoing vehicles do not have to back out along the approach.

2-7.7 Barriers.

On all approaches, provide safety barriers adequate for the type of traffic using the facility (pedestrian, vehicular, and/or rail). However, safety barriers should not be provided in areas where mission operations, such as ship or small craft berthing, are performed. Rail only approaches do not normally require safety barriers. Provide traffic

barriers between pedestrian and traffic lanes. Conformance with AASHTO *Guide Specifications for Bridge Railings* and AASHTO *Bridge Guide and Manual Interim Specifications* is required for traffic and pedestrian barrier design.

2-8 STRUCTURAL TYPES.

2-8.1 General.

The three major structural types for piers and wharves are open, solid, and floating. Open type piers and wharves are pile supported platform structures that allow water to flow underneath. Figure 2-7 illustrates the open type. Another type of an open type pier is a jack-up barge. Solid type uses a retaining structure such as anchored sheet pile walls or quaywalls, behind which a fill is placed to form the working surface. Solid type will prevent stream flow underneath. Figure 2-7 illustrates the solid structural type. Floating type is a pontoon structure that is anchored to the seabed through spud piles or mooring lines and connected to the shore by bridges or ramps. A floating double deck pier is shown in Figure 2-8. For additional information, contact NAVFAC Atlantic - Engineering Criteria & Programs.

Figure 2-7 Open and Solid Type Piers/Wharves

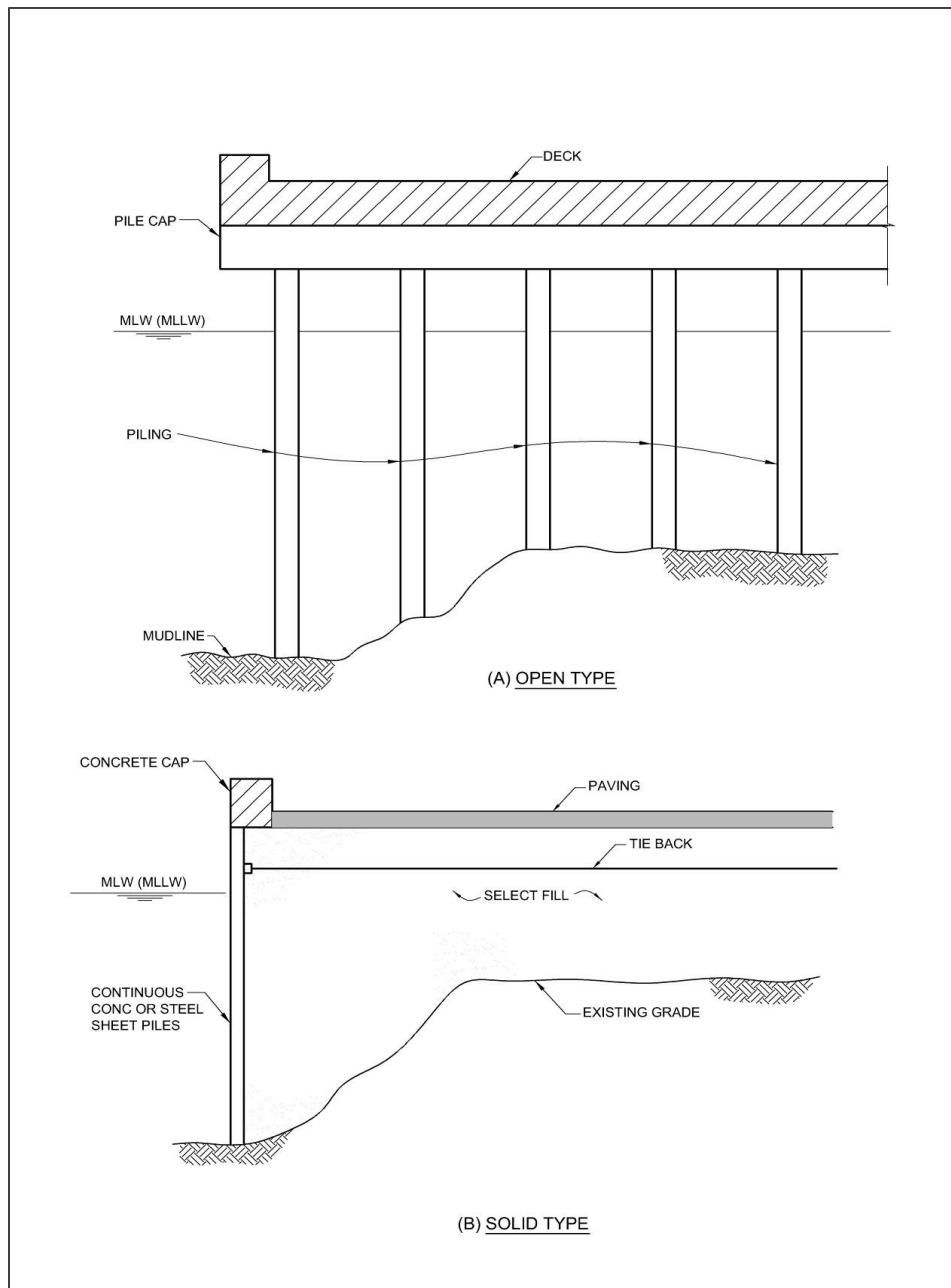
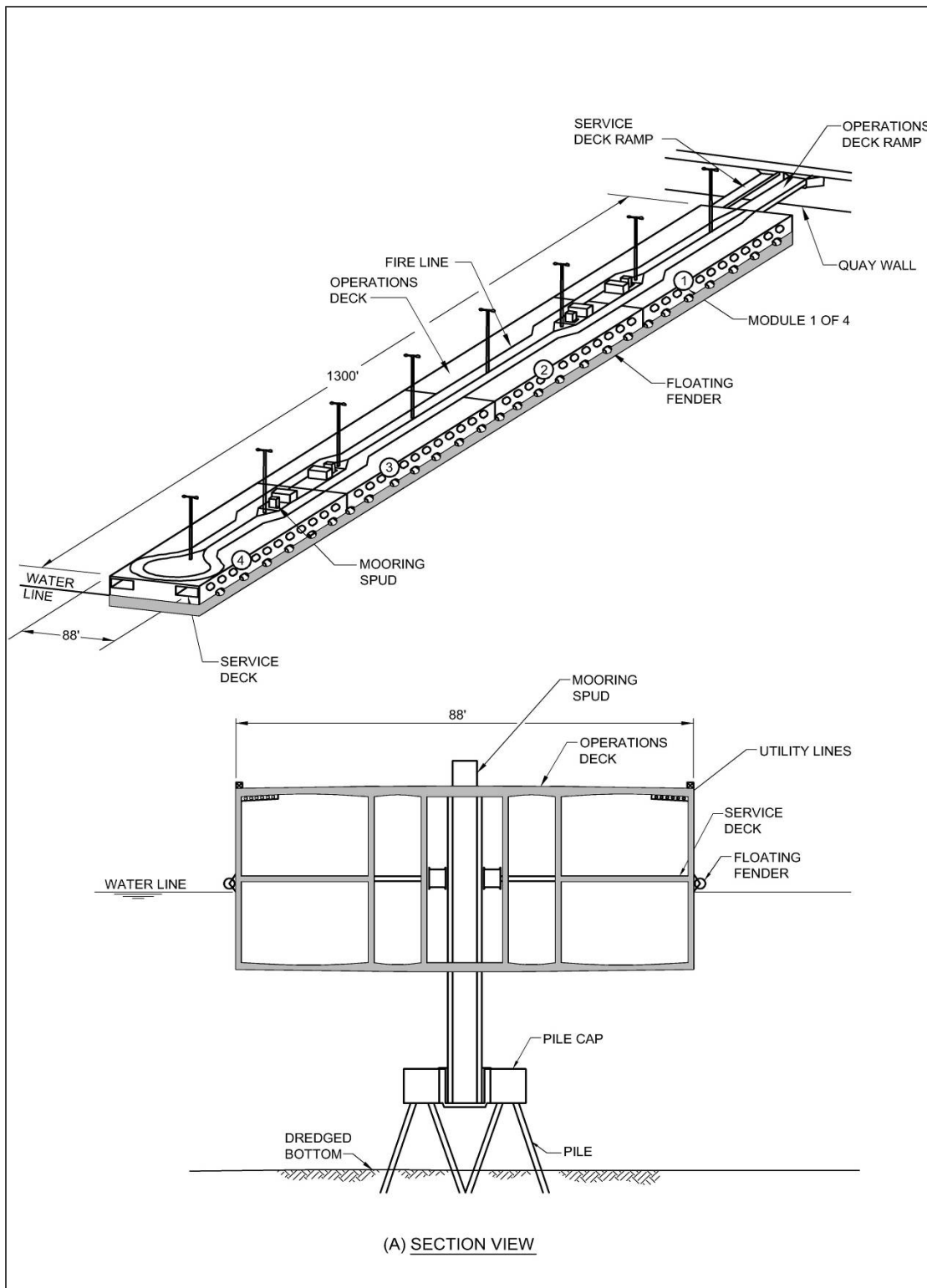

Figure 2-8 Floating Double Deck Pier



2-8.2 Selection of Type.

Numerous factors influence the selection of one structural type over the other. Evaluate each of these factors against the construction and operating costs of the facility before a final decision is made on the structural type. Place greater emphasis on selecting the type that will withstand: unexpected berthing/mooring forces, adverse meteorological and hydrological conditions, and the corrosive effects of a harsh marine environment such that it will require little or no maintenance. The geotechnical characteristics of a given site, and economic analysis of alternate structural types will often dictate structural requirements. For instance, in areas with poor near surface soils but with good end bearing for piles, an open pile supported structure with a shallow bulkhead (or no bulkhead) will be most economical. Conversely, in areas with good near surface soils and poor pile bearing, a solid bulkhead may be more economical. Consider environmental impacts when selecting type.

2-8.2.1 Shoreline Preservation.

The structural type is seriously influenced by aquatic and plant life existing along the shore of the planned facility. In environmentally sensitive areas such as river estuaries, the solid-type wharf, which would disturb or destroy a considerable length of shoreline, should not be considered. Select the open structural type, which would have the least impact on the shoreline.

2-8.2.2 Bulkhead Line.

When the facility extends beyond an established bulkhead line (the limit beyond which continuous solid-type construction is not permitted) use open type construction.

2-8.2.3 Tidal or Stream Prisms.

Where it is required to minimize restrictions of a tidal or stream prism (the total amount of water flowing into a harbor or stream and out again during a tidal cycle) use open type construction.

2-8.2.4 Littoral Drift.

Along shores where littoral currents transporting sand, gravel, and silt are present, use open type construction to mitigate shoreline erosion and accretion.

2-8.2.5 Ice.

In general, open type structures are vulnerable and should be carefully investigated at sites where heavy accumulations of sheet or drift ice occur. Also, when ice thaws, large blocks of ice may slide down the piling, impacting adjacent batter or plumb piles. Thus, the solid type may be preferable at such sites. To mitigate the effects of large blocks of ice sliding up and down the plumb and battered piles within the tide fluctuation zone, consider protecting piles from abrasion utilizing pile jackets within the tide fluctuation zone + 2 feet (0.6 m) beyond the tidal fluctuation. Consider bulkhead protection from the

ice abrasion utilizing cementitious epoxy coating for the exposed surface of the sheet pile bulkhead.

2-8.2.6 Earthquake.

Consider the potential for liquefaction in areas of high seismic activity. Often, mitigation measures, such as soil improvements have been used. Recent wharf projects in Guam are good examples. P-204 Wharf Improvements Uniform and Tango used stone columns to mitigate liquefaction of soils behind a new bulkhead. P-518 X-Ray Wharf Improvements used deep soil cement mixing to mitigate liquefaction and create a soil-cement structure which would significantly reduce loads on the new bulkhead structure. When considering liquefaction, a number of good references are available, namely:

- a. TR-2077-SHR, *Seismic Design Criteria for Soil Liquefaction (1997)*
- b. NCEER-97-0022, *Proceedings of the NCEER Workshop on Evaluation of Liquefaction Resistance of Soils*
- c. NCHRP Report 611, *Seismic Analysis and Design of Retaining Walls, Buried Structures, Slopes, and Embankments (2008)*
- d. ASCE 7-10, *Minimum Design Loads for Buildings and Other Structures*
- e. ASCE/COPRI 61-14, *Seismic Design of Piers and Wharves*

In areas of high seismic activity, carefully consider construction utilizing sheet pile bulkheads or walls because of the high lateral earth pressures that can develop on the sheet piling. When a pile-supported platform (with curtain wall) is used for a wharf structure in conjunction with hydraulic fill, which is susceptible to liquefaction, consider a rock dike to resist the lateral forces that may be caused by liquefaction of the fill. The use of an engineered soil filter fabric between the rock dike and granular fill should also be considered. In areas of extremely high seismic risk, and where tsunamis and seiches are anticipated, seriously consider the floating type as it is less likely to be affected by or will suffer only minor damage from the seismic activity. The floating double deck pier has been developed as a viable option in areas of high seismicity. This is due to the fact that the pier structure is basically isolated from the seismic event at the interface of the pier structure and the founding shaft. Rubber arch fenders in the pier's moonpool accomplish the desired seismic isolation.

2-8.2.7 Water Depths.

Consider open type construction in all depths of water when accommodating naval vessels, cargo vessels, and tankers. Depth limits for solid-type construction, utilizing sheet pile bulkheads, are imposed by the magnitude of the applied surcharge, subsurface conditions, and freeboard of the bulkhead above the low waterline. Generally, anchored sheet pile bulkheads may be considered in water depths up to 30 to 35 feet (9.1 to 10.7 m) where favorable soil conditions exist. When greater water depths are required at solid type bulkhead structures, consider the use of relieving

platforms, bulkheads consisting of reinforced high-strength steel sheet piles, or cellular construction.

2-8.2.8 Subsurface Conditions.

Generally, subsurface conditions do not limit the use of open type construction. For almost all subsurface conditions, with the possible exception of rock close to the harbor bottom surface, suitable piles or caissons can be designed. Where rock is close to the surface and pile seating may be difficult and costly, consider cellular construction. When open type construction is required in an area where rock is close to the surface, piles should be socketed and anchored into the rock. Consider sheet piling, used for bulkheads or retaining walls in conjunction with platform wharf structures or combination piers, only when subsurface conditions indicate that suitable anchorage and restraint for the toe of the sheet piling can be achieved and where select material is available for backfill.

2-8.2.9 Fill Loss.

When precast concrete and steel sheet pile bulkheads are used in pier and wharf construction, take special care to prevent fill leaching through the interlocks, causing subsidence of retained fill. Install a filter blanket or other method that could prevent or control fill leaching to reduce subsidence and consequent paving maintenance.

2-8.2.10 Construction Time.

Where an existing pier or wharf has to be replaced in active naval stations, the floating type has the advantage of minimizing the "downtime." Conventional construction may take too long where the loss of berths cannot be tolerated. The floating type in such situations may turn out to be the most expedient.

2-8.2.11 Ship Contact.

In certain situations, where tugboats or camels are not available, sheet pile bulkheads located along the offshore face of pier and wharf structures may be less desirable than open type construction because of the greater danger for contact between the sheet piling and the bulbous bow or sonar dome of a ship during berthing and unberthing maneuvers.

2-8.2.12 Track Mounted Crane.

Where a track-mounted crane is required for the pier or wharf, the solid type may not be suitable. The susceptibility of the solid filled type to settlement and movement will make it very difficult to maintain the close tolerance required for rail gage, elevation, and alignment. The surcharge loading on the sheet pile will also be considerable. For such cases, use an independent pile supported track.

2-8.3 Construction.

Several aspects of construction that are unique to each structural type should be considered.

2-8.3.1 Open.

For open type wharves and landside ends of open piers, the following schemes should be considered for retaining upland fill:

- a. Platform on Piles and a Curtain Wall at the Inshore Face. See Figure 2-9. The underwater slope should be as steep as possible, as limited by both constructional and geotechnical parameters, thus making the pile-supported platform narrow and more economical. In seismically active areas, where hydraulic fill susceptible to liquefaction is used for upland fill, a rock dike may be used instead of the granular fill dike to resist the lateral forces caused by liquefaction of the fill. The use of a filter fabric also should be considered at the hydraulic fill interface.
- b. Platform on Piles and a Sheet Pile Bulkhead at the Inshore Face. See Figure 2-9. The sheet pile bulkhead permits a narrower platform. The cost tradeoff between platform width and bulkhead height should be investigated as the bulkhead may be found to cost as much or more than the pile supported platform width saved.

Figure 2-9 Open Type Wharf Concepts

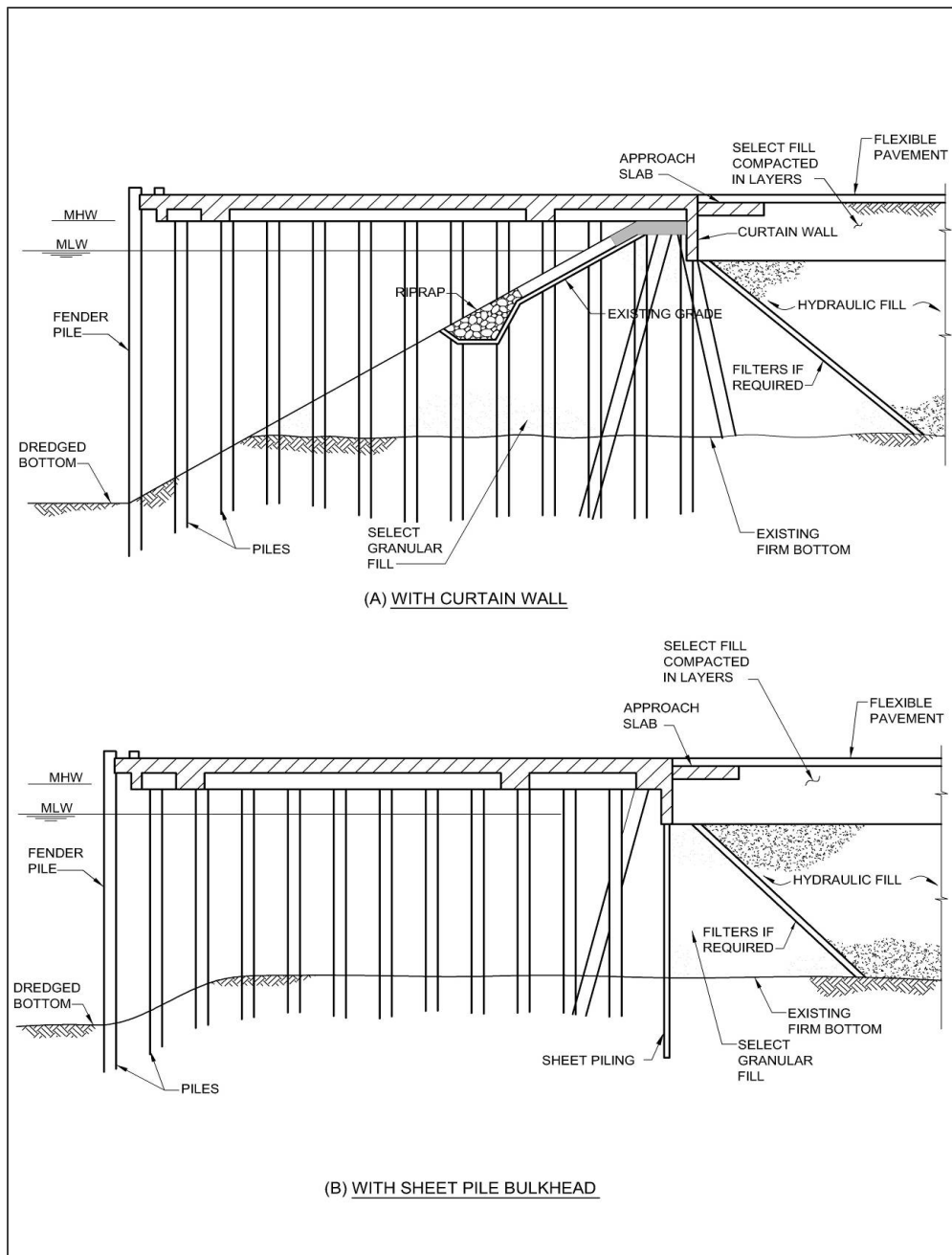

2-8.3.2 Solid.

Retaining structures may be constructed by the following means:

- a. Sheet Pile Bulkhead. See Figure 2-10. The bulkhead consists of a flexible wall formed of steel or concrete sheet piling with interlocking tongue and groove joints and a cap of steel or concrete construction. The bulkhead is restrained from outward movement by placing an anchorage system above the low water level. Many types of anchorage systems can be used. The most common types in use in the United States consist of anchor rods and deadman anchors. The latter could be made of concrete blocks, steel sheet piling, or A-frames of steel, concrete, or timber piles. In countries outside the United States, an anchorage system consisting of piles, attached near the top of the sheet pile bulkhead and extending at batters up to 1 on 1 to embedment in firm material, is often used. Rock or earth anchors consisting of high-strength steel rods or steel prestressing cables are sometimes preferred in place of the anchor batter piles. Provide granular free-draining material adjacent to sheet pile bulkheads, extending from dredged bottom to underside of pavement on grade. Grade this material to act somewhat as a filter to limit subsequent loss of fines through the sheet pile interlocks. Placement of free-draining material should be in stages, commencing at the intersection of sheet piling and dredged bottom and progressing inshore. Eliminate mud and organic silt pockets. In general, do not consider hydraulic fill for backfill unless provision is made for the effects of fill settlement, potential liquefaction of fill in seismic zones, and high pressure exerted on sheet piling. Consider vibro-compaction for consolidation of hydraulic fill. In areas with tidal ranges greater than 4 feet (1.2 m), provide 2 inch (51 mm) diameter weep holes for the sheet piles above the mean low water level. If a waterline is located behind the bulkhead, provide weep holes. When weep holes are used, provide graded filters to prevent loss of finer backfill material. Provide openings in pavement or deck for replenishment of material in order to compensate for loss and settlement of fill. In general, flexible pavement using asphaltic concrete is preferred over rigid pavement with Portland cement concrete, as it is more economical to maintain and better able to accommodate underlying settlement.
- b. Sheet Pile Bulkhead and Relieving Platform. The relieving platform is used in conjunction with a sheet pile bulkhead to reduce the lateral load on the sheet piling created by heavy surcharges and earth pressures. See Figure 2-10. Lateral restraint is provided by the batter piles supporting the relieving platform. A variation of this type of construction is to use only vertical piles for the relieving platform and to furnish an independent anchorage system consisting of tie rods and deadman, similar to the types specified for sheet pile bulkheads.

Figure 2-10 Closed Type Wharf Concepts

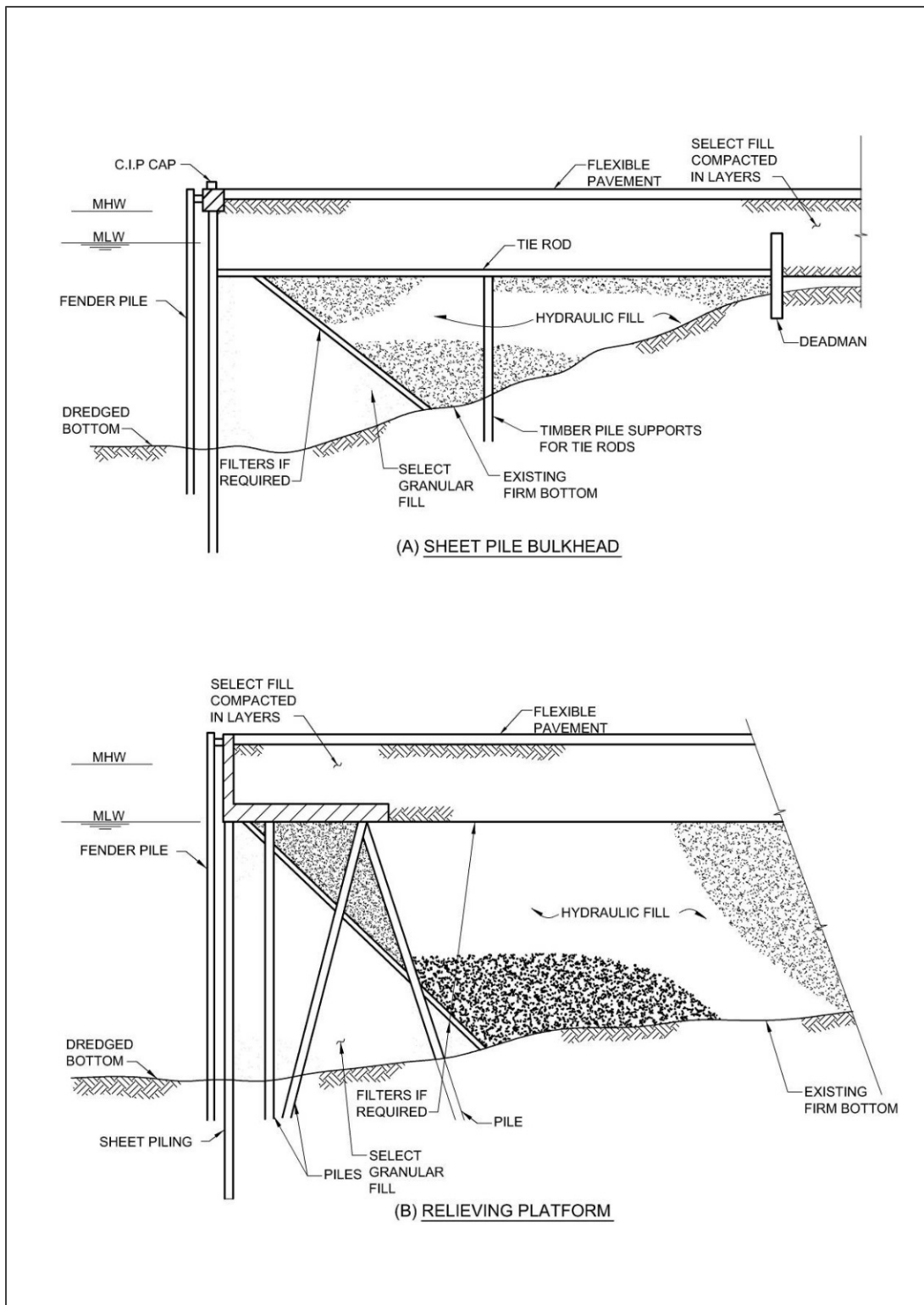

- c. Cellular Construction Consisting of Sheet Pile Cells. For design procedures and selection of type, see UFC 3-220-01, *Geotechnical Engineering* and USACE EM 1110-2-2503, *Engineering and Design: Design of Sheetpile Cellular Structures, Cofferdams, and Retaining Structures*. Cellular structures are gravity retaining structures formed from the interconnection of straight steel sheet piles into cells. Strength of cellular structures derives from resistance to shear caused by friction and tension in the sheet pile interlocks and also from the internal shearing resistance of the fill within the cells. Accordingly, clean granular fill materials such as sand and gravel are usually used to fill the cells. Exercise extreme care in the construction of cellular structures because excessive driving onto boulders or uneven bedrock may cause ruptured interlocks, which can later unzip under hoop tension (from filling) and cause failures of the cell. Similarly, carefully control all aspects of fill placement, as cofferdams can unzip and cause sudden (little to no warning) failures of the cell. Compensate for movement and expansion of cells during construction of the cells and carefully control fill placement to satisfactorily maintain alignment of the face of the wharf. A concrete facing may be employed to protect the steel within the tidal zone. Cellular structures are classified according to the configuration and arrangement of the cells. The basic types are discussed below and are shown on Figure 2-11.
- Circular. This type consists of individual large-diameter circles connected together by arcs of smaller diameter. Each cell may be completely filled before construction of the next cell is started. Construction of this type is easier than the diaphragm type because each cell is stable when filled and thus may be used as a platform for construction of adjacent cells. Because the individual cells are self-supporting units, accidental loss of one cell will not necessarily endanger adjoining cells. Compared to a diaphragm type cellular structure of equal design, fewer piles per linear foot of structure are required. The diameter of circular cells is limited by the maximum allowable stresses in the sheet pile interlocks and, when stresses are exceeded, cloverleaf cells are used.
 - Diaphragm. This type consists of two series of circular arcs connected together by diaphragms perpendicular to the axis of the cellular structure. The width of cells may be widened by increasing the length of the diaphragms without raising interlock stress, which is a function of the radius of the arc portion of the cell. Fill cells in stages so that the heights of fill in adjoining cells are maintained at equal levels to avoid distortion of the diaphragm walls. Diaphragm type cells present a flatter faced wall than circular cells and are considered more desirable for marine structures.

Figure 2-11 Solid Type, Cellular Construction

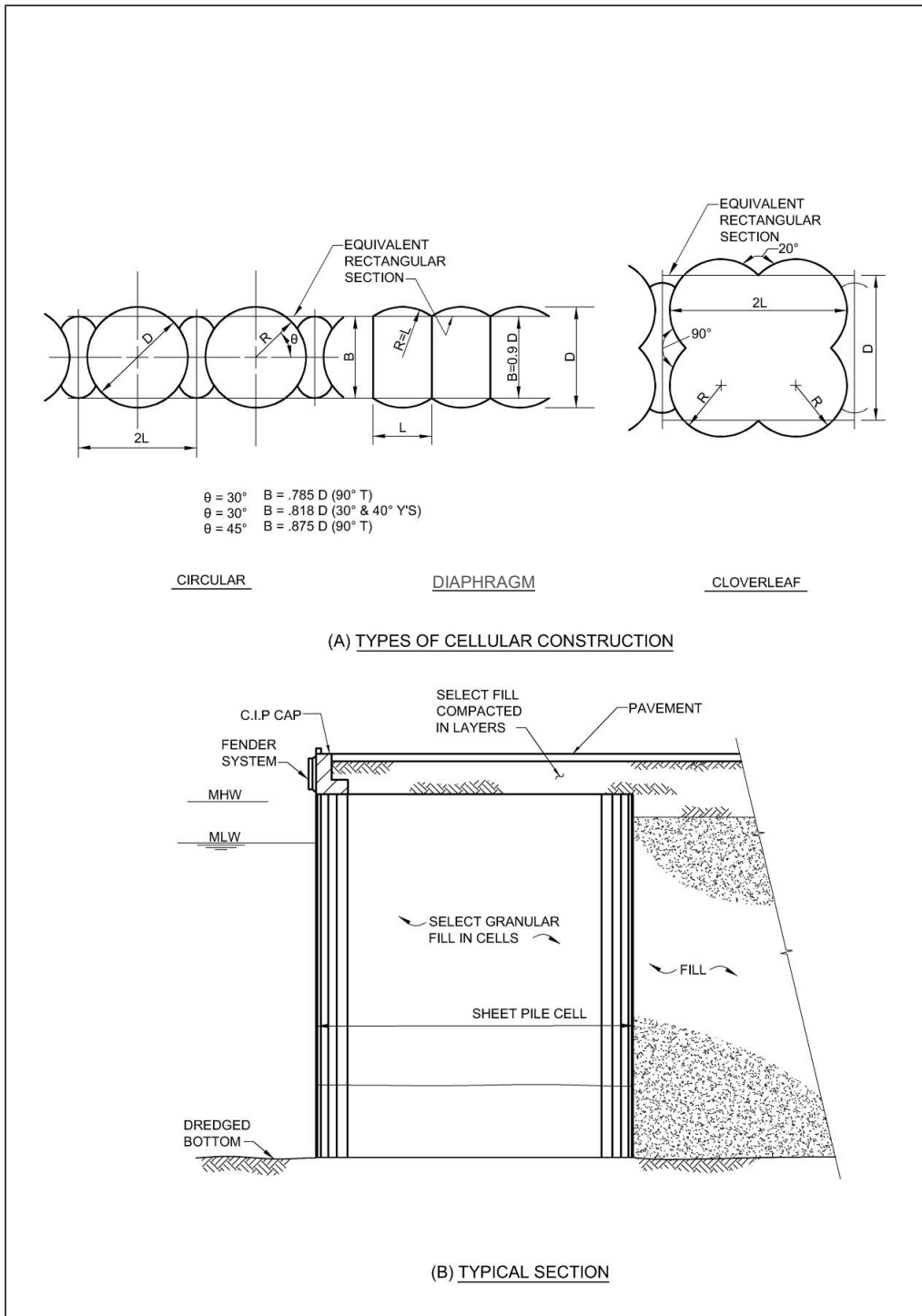

- Cloverleaf. This type is a modification of the circular cell type and is generally used in deep water where the diameter required for stability would result in excessively high interlock stress if diaphragms were not added.
 - Modified Open Cell. This type relies on steel sheet walls as a form of tieback to the fill.
- d. Reinforced Concrete Caisson. See Figure 2-12. In this type of construction, concrete caissons are cast in the dry, launched, and floated to the construction site where they are sunk on a prepared foundation. The caisson is filled with gravel or rock and a cast-in-place retaining wall is placed from the top of the caisson to the finished grade. This type of construction is prevalent in countries outside the United States. Reinforced concrete caissons come in two variations: closed and open end caissons (caissons without the bottom slab). Closed end caissons are normally floated and then sunk in place. Open bottom caissons are barge delivered, but are easier to install and have better rotational stability due to mobilization of the infill soil shear action (see cellular cofferdams). Closed end caissons require sub base leveling and sub base stabilization for prevention of the caisson roll off, particularly in areas with extreme wave climate. Sometimes, caissons are fabricated as the ring modules, barge delivered and preassembled at the site prior to installation.
- e. Precast Concrete Blocks. See Figure 2-12. This form of solid wharf is a gravity type wall made up of large precast concrete blocks resting on a prepared bed on the harbor bottom. A select fill of granular material is usually placed in the back of the wall to reduce lateral earth pressures. This type of construction is popular outside the United States.

2-8.3.3 Floating.

Construction of the floating type usually requires a flood basin, graving dock, or dry dock. The units are essentially constructed in the dry and floated out and transported (on their own or on barges) to the site. Availability of such a facility and transportation of the floating units through open ocean waters and restricted inland waters for deployment at the site are serious considerations. In this respect, the floating type has a significant advantage over others in that the bulk of construction activity can be shifted to other parts of the country where labor, economic, and environmental conditions are more favorable. Other concepts of construction such as barge-mounted construction and floating-form construction are described in NCEL UG-0007, *Advance Pier Concepts, User's Guide*.

Figure 2-12 Solid Type, Caisson and Concrete Block Construction

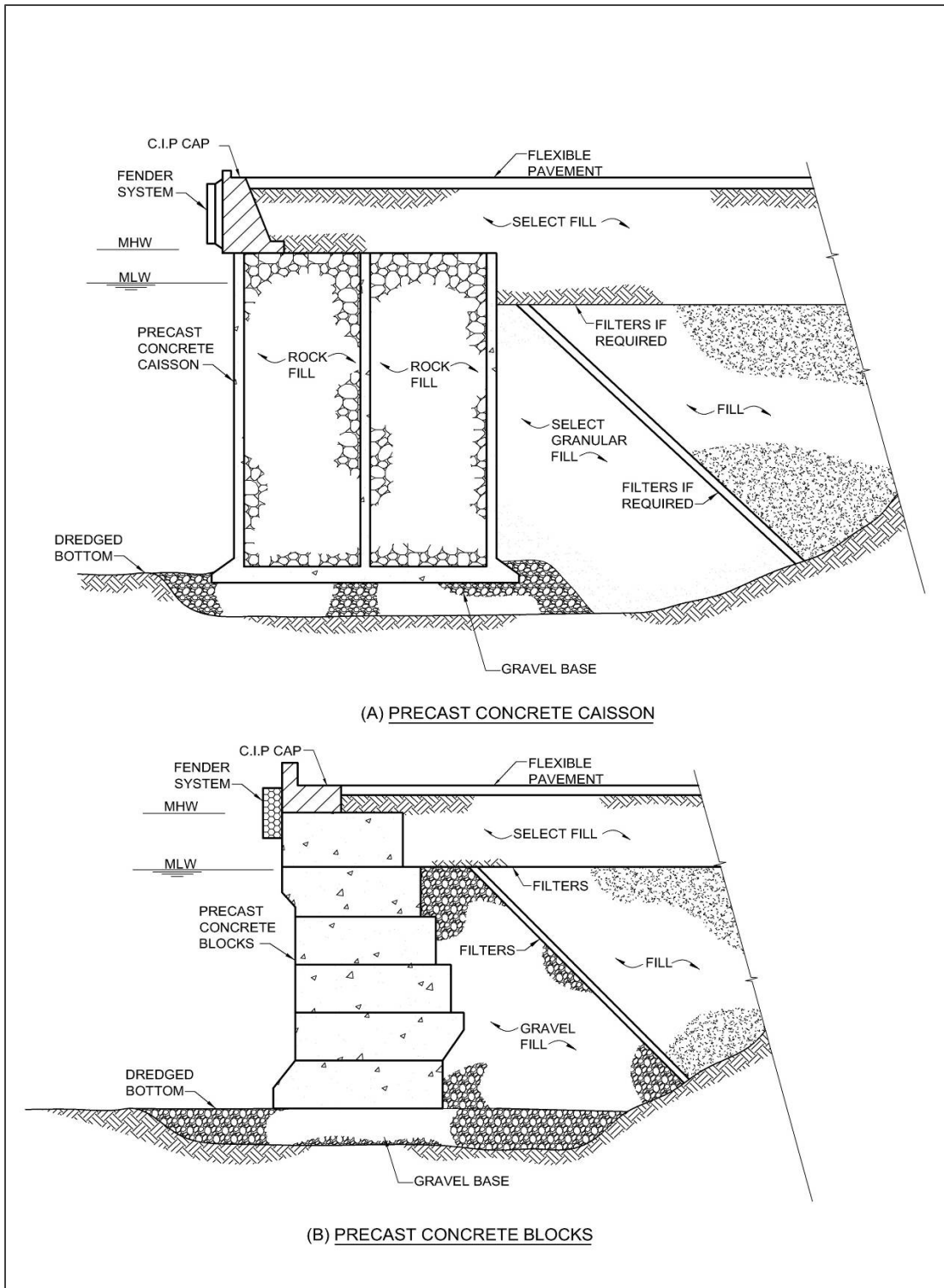

2-8.3.4 Jack-up Barge.

This type consists of a structural steel seaworthy barge provided with openings for steel caissons, which are lowered to the harbor bottom when the barge has been floated into final position. The barge may be completely outfitted during construction with ship fenders, deck fittings, and utilities including power, lighting, communications, water supply, sanitary facilities, etc., so that once it is jacked into position and utility tie-ins are made, it is ready to receive ships. Circular pneumatic gripping jacks, mounted on the deck above the caisson openings, permit the barge to be elevated in steps. The barge is loaded with steel caissons, a crane for pile erection, and other tools and materials required for the fieldwork, and is towed to the site. At the site, the barge is moved into approximate position and the caissons are dropped through the jacks and hull by the crane. The caissons, suspended above the harbor bottom and supported by engaging the jacks, are then released and seated into the harbor bottom by dead weight. The barge-like deck is jacked to the required elevation and locked. Each caisson is then released from its jack and driven to refusal or required penetration. When all caissons are driven, the hull of the barge is welded to the caisson, the jacks are removed, and the caissons are cut off flush with the deck and capped with steel plates. In some situations, the caissons are filled with sand to avoid buoyancy problems. Jack-up barge type structures are also constructed using hydraulic jacks and open-trussed towers instead of pneumatic jacks and circular caissons.

2-9 HYDRAULIC FILL.

The soil drawn up by the suction head of a dredge, pumped with water through a pipe, and deposited in an area being filled or reclaimed is referred to as "hydraulic fill." At port and terminal facilities, where land is not available onshore and where dredging is required to provide adequate water depths for vessels at berths and approach channels, hydraulic fill is commonly used for land reclamation because of its availability and low cost. Hydraulic fill may be of good quality, consisting of granular materials, or may consist of plastic organic silt, which is considered poor quality. When hydraulic fill is used, investigate the stability of the structure retaining the fill, taking into consideration the effects of adjacent surcharge loadings in addition to the loadings from the fill. The placement of a select granular fill adjacent to the retaining structure may be required if the hydraulic fill is of poor quality. Hydraulic fill is in a loose condition when placed. To avoid fill settlements due to loadings from other structures, stacked cargoes, and mobile equipment, stabilization of the fill may be required. In areas of seismic activity, investigate the liquefaction of hydraulic fills. Stability with regard to both settlements and liquefaction may be enhanced by methods such as deep densification or by use of sand drains. Material other than hydraulic fill should be used when the cost of material obtained from onshore borrow areas is cheaper than the cost of material obtained from offshore borrow areas or where good quality fill material is required and is not available offshore.

CHAPTER 3 LOAD REQUIREMENTS

3-1 GENERAL.

Where loading conditions exist that are not specifically identified in this UFC, rely on accepted industry standards. Where applicable, reference is made to UFC 3-301-01, *Structural Engineering*. However, in no case will other standards supersede the requirements provided by this UFC.

3-2 DEAD LOADS.

3-2.1 General.

The dead load consists of the weight of the entire structure, including all the permanent attachments such as mooring hardware, light poles, utility booms, vaults, sheds, and service utility lines. A realistic assessment of all present and future attachments should be made and included. For floating piers and wharves, overestimating of dead loads would overstate draft and could have a significant effect on cost.

3-2.2 Unit Weights.

Use actual and available construction material weights for design. See Table 3-1 for unit weights that should be used for construction materials (unless lesser unit weights can be demonstrated by local experience). Pertinent information may also be found in ASCE 7, *Minimum Design Loads for Buildings and Other Structures*.

Table 3-1 Unit Weights

Material	Unit Weight (pcf)
Steel or cast steel	490
Cast iron	450
Aluminum alloys	175
Timber (untreated)	40 to 50
Timber (treated)	45 to 60
Concrete, reinforced (normal weight)	145 to 160
Concrete, reinforced (lightweight)	90 to 120
Compacted sand, earth, gravel, or ballast	150
Asphalt paving	135 to 150

3-3 VERTICAL LIVE LOADS.

3-3.1 General.

Although a number of loading conditions will be presented in subsequent sections, the advent and subsequent heavy usage of mobile cranes on piers will generally produce the controlling loading condition. For example, on a general purpose berthing pier, a design drawing will typically present different design live loads including uniform, vehicular (i.e. HS 20-44), forklift, and maximum outrigger float load. The outrigger load from the mobile crane invariably controls with the other loads more or less provided for informational purposes. Further, it is incumbent upon the designer to identify and document all of the particular loadings associated with his design that may not be included in the discussions in this section.

3-3.2 Uniform Loading.

See Table 3-2 for recommended uniform loadings for piers and wharves. Impact is not applied when designing for uniform loads.

Table 3-2 Vertical Live Loads for Pier and Wharf Decks

Classification	Uniform Loading (psf)	Mobile Crane (tons)	Rail-Mounted Crane (tons)	Other Handling Equipment (tons)
Ammunition	600	90	--	20-lift truck
Berthing (carriers)	800	140	--	20-lift truck
Berthing (all others)	600	90	--	20-lift truck
Berthing (submarines)	600	90	--	20-lift truck
Repair	600	140	60/151 Portal	20-lift truck
Fueling	300	50	--	10-lift truck
Supply (general cargo)	750	140	--	20-lift truck
Supply (containers)	1,000	140	40/50 (long tons) Container	20-lift truck 33-straddle carrier

3-3.3 Truck Loading.

Calculate truck wheel loads in accordance with the AASHTO *Standard Specifications for Highway Bridges* except as modified below. Figure 3-1 is provided to show both AASHTO LRFD Design Truck and Design Tandem. In the design of slabs, beams, and pile caps, apply an impact factor of 15 percent. Structural elements below the pile caps need not be designed for impact. When truck loading is transferred through 1.5 feet (0.46 m) or more of crushed rock ballast and paving, and for filled construction, the impact forces need not be considered for design. Also, check with local activity for use

of an overload vehicle such as weapons cradles, missile hauling vehicles, etc. which may have significantly higher wheel loads.

Figure 3-1 AASHTO LRFD Design Truck and Design Tandem

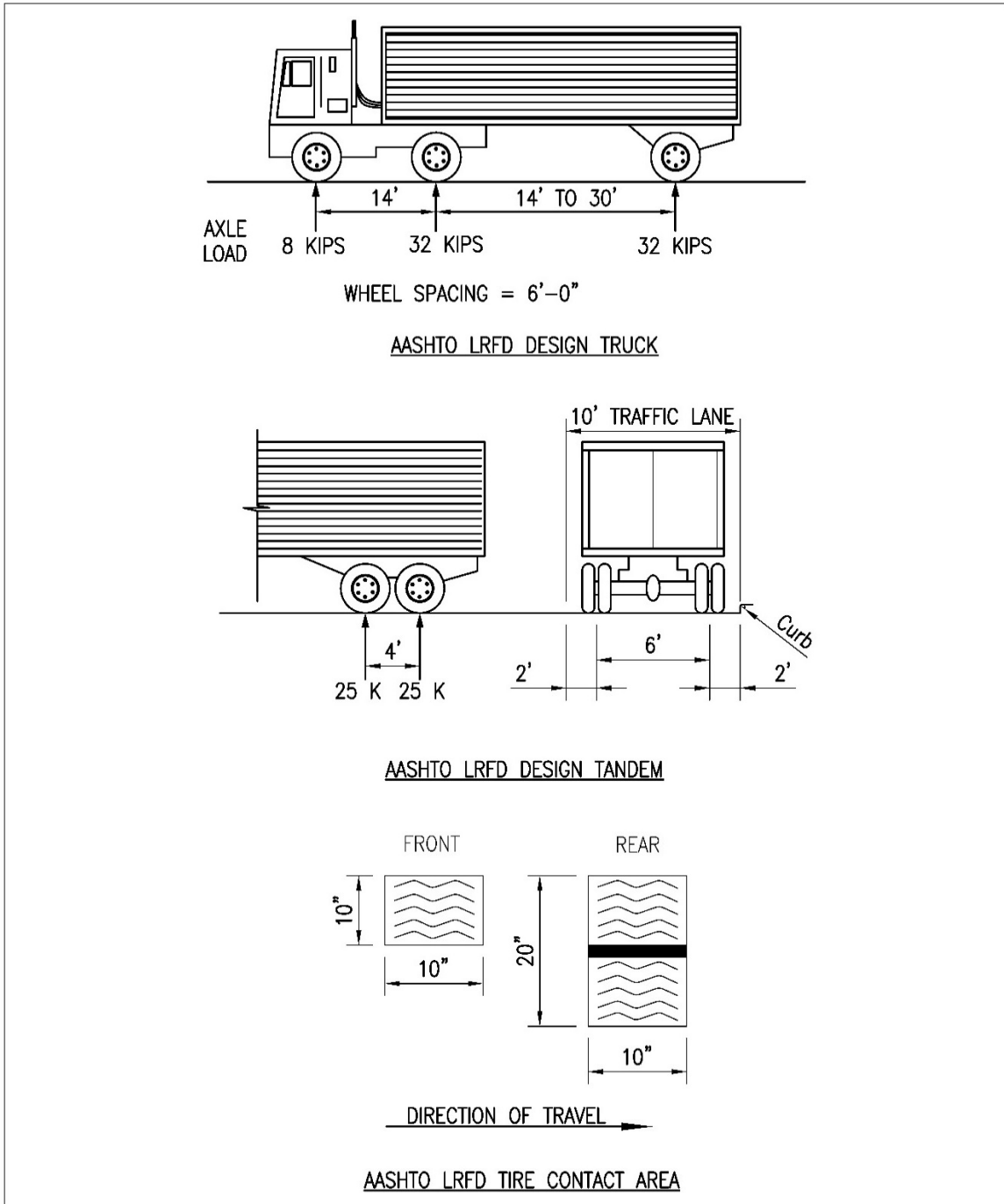

3-3.4 Rail-Mounted Crane Loading.

3-3.4.1 Portal Cranes.

For design of new piers and wharves, obtain specific crane wheel loads for the actual crane to be used. If the crane resources are not known at the time of design, consult the Navy Crane Center for design loading and crane procurement. When choosing design wheel loads, provide flexibility, considering different makes of cranes and ultimate crane replacement as well as future use of the pier or wharf. Piers and wharves have greater longevity than rail-mounted cranes. To this end, a wheel load of 110,000 pounds (489 kN) minimum on 4-foot (1.2 m) centers allows for a practical range of options. See Table 3-2 for typical rated capacities of cranes for a variety of pier and wharf deck uses.

Figure 3-2 lists a sampling of wheel loads for 60 ton (534 kN) and 151 ton (1343 kN) capacity portal cranes recently procured by the Navy. These cranes were procured around capacities of existing piers and wharves and have wheel loads that are somewhat restrictive for new design. The values provided are typical for existing equipment used by the Navy and are useful for design feasibility studies on existing structures. The rail gage should be approximately 30 feet (9.1 m) minimum for a 60 ton (534 kN) capacity portal crane, and up to 40 feet (12.2 m) for a portal crane of 100 tons (890 kN) capacity or greater. For handling of fuel containers at repair piers, portal cranes with up to 151-ton (1343 kN) capacity are required.

3-3.4.2 Container Cranes.

See Figure 3-3 for crane configuration and wheel loads of container cranes and Table 3-2 for the rated capacities of container cranes applicable to piers and wharves. The configuration and wheel loads are derived from several manufacturers and should be used only as a guide. A recent trend in the shipment of containerized cargo is to use larger ships, and this is the driving force in the design of container cranes. The size of the ship to be serviced will dictate the capacity, configuration, operational characteristics, and gage of the crane. The evolution in container crane design has been to increase the gage to 100 feet (30.5 m) and outreach on the boom to 150 feet (45.7 m) and larger while maintaining the lift capacity between 40 and 50 long tons (399 and 498 kN). Hence, specific information on the size of the ship to be serviced and details from the crane manufacturer needs to be obtained for final crane design.

3-3.4.3 Wheel Load Uncertainty.

Portal and container cranes are usually procured separately from the construction funds. The maximum allowable wheel loads are normally specified on the crane procurement documents. The number and spacing of wheels are critical to the structural capacity of an existing facility and structural design of a new facility. Having established the required capacity and configuration of a crane, the designer of a pier or wharf should consult with the Navy Crane Center and obtain wheel loads for which the supporting structure should be designed. In the absence of hard information, the 110,000 pound (489 kN) wheel load presented in the previous paragraph on portal

cranes may be used. However, the container crane wheel loads presented in Figure 3-3 are only provided as a guide. Determine the design characteristics noted in the previous paragraph on container cranes in order to determine realistic wheel loads.

Figure 3-2 Wheel Loads for Portal Cranes

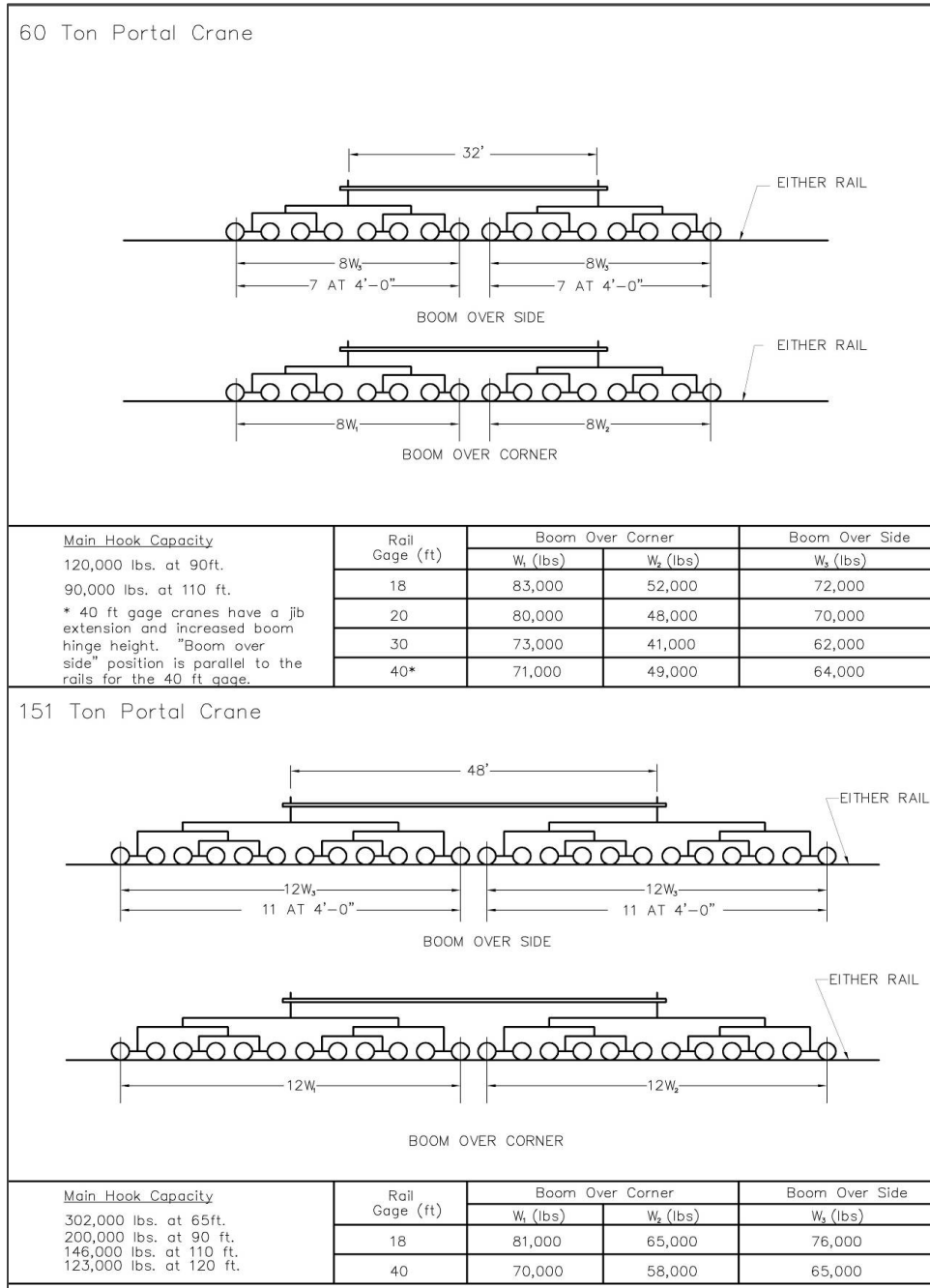
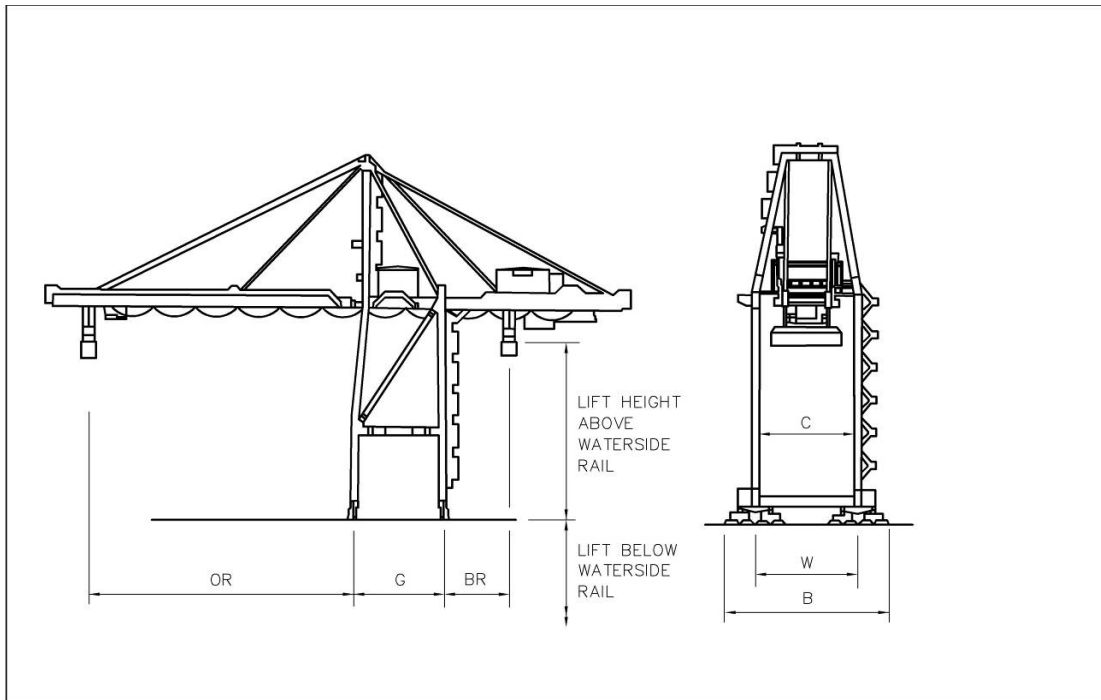

Figure 3-3 Configuration and Wheel Loads for Container Cranes



ITEM		CRANE CAPACITY		
		40' LONG TONS	50' LONG TONS	
GAUGE – G		50' TO 100'	100'	
OUTREACH – OR		115' TO 155'	125' TO 172'	
BACK REACH–BR		30' TO 60'	30' TO 60'	
WHEEL BASE – W		45' TO 55'	45' TO 55'	
CONTAINER CLEARANCE – C		55' TO 60'	55' TO 60'	
BUMPER TO BUMPER – B		79' TO 90'	85' TO 90'	
WHEEL SPACING (8 WHEELS/LEG)		4' TO 5'	4.5' TO 5'	
LIFT HEIGHT ABOVE WATERSIDE RAIL		90' TO 110'	89' TO 110'	
LIFT HEIGHT BELOW WATERSIDE RAIL		55'	65'	
MAXIMUM WHEEL LOAD IN KIPS (UNFACTORED WITH 10 PSF WIND)	OPERATING	WATERSIDE RAIL	87 ^k TO 120 ^k	110 ^k TO 170 ^k
		LANDSIDE RAIL	75 ^k TO 112 ^k	95 ^k TO 125 ^k
	STOWED	WATERSIDE RAIL	56 ^k TO 135 ^k	90 ^k TO 150 ^k
		LANDSIDE RAIL	60 ^k TO 150 ^k	100 ^k TO 165 ^k

3-3.4.4 Impact.

Apply an impact factor of 25 percent to the maximum listed wheel loads for the design of deck slab, crane girders, and pile caps. The impact factor is not applicable to the design of piles and other substructure elements.

3-3.5 Mobile Crane Loadings.

The deck design for open and floating structural types of piers and wharves is usually controlled by mobile crane loading. However, the operational constraints imposed by under specifying mobile crane loadings are severe. Consequently, take care to specify realistic loading. Refer to Table 3-2 for designated mobile cranes applicable to each functional type of pier and wharf. As a minimum design the pier or wharf for the designated mobile crane, however, check with the local activity to confirm whether a crane larger than that designated could be used at the facility, as the additional structural design cost for larger mobile cranes may be minimal at the preliminary design stage. Larger cranes may be used at a facility provided the demands are less than that of the design cranes listed in Figure 3-4, and Table 3-3. To assist the facility determine suitability of larger cranes provide the following on the design drawings structural notes:

- The maximum single outrigger load, ground bearing pressure.
- The maximum double outrigger load, ground bearing pressure, outrigger spacing.
- The maximum single axle load, tire pressure, footprint.
- The maximum multiple axle load, tire pressure, footprint, axle spacing, maximum number of axles.

3-3.5.1 Wheel Loads.

See Figure 3-4 for wheel loads for 50-, 70-, 90-, 115-, and 140-ton capacity mobile cranes. The information in Figure 3-4 is for typical truck cranes, although rough-terrain type mobile cranes are also used on piers and wharves. Tire contact area should be as defined by AASHTO LRFD. As a rule of thumb, ground pressures for "on rubber" lifts are about 10 percent higher than tire inflation pressure. Crane manufacturers recommend that the majority of lifts be made on outriggers. In addition, capacities for "on rubber" lifts are substantially less than for "on outrigger" lifts. Hence, loads for "on rubber" lifts are not listed. Design all piers and wharves and their approaches for the wheel loads from the designated truck crane.

Figure 3-4 Wheel Loads and Dimensions for Truck Cranes

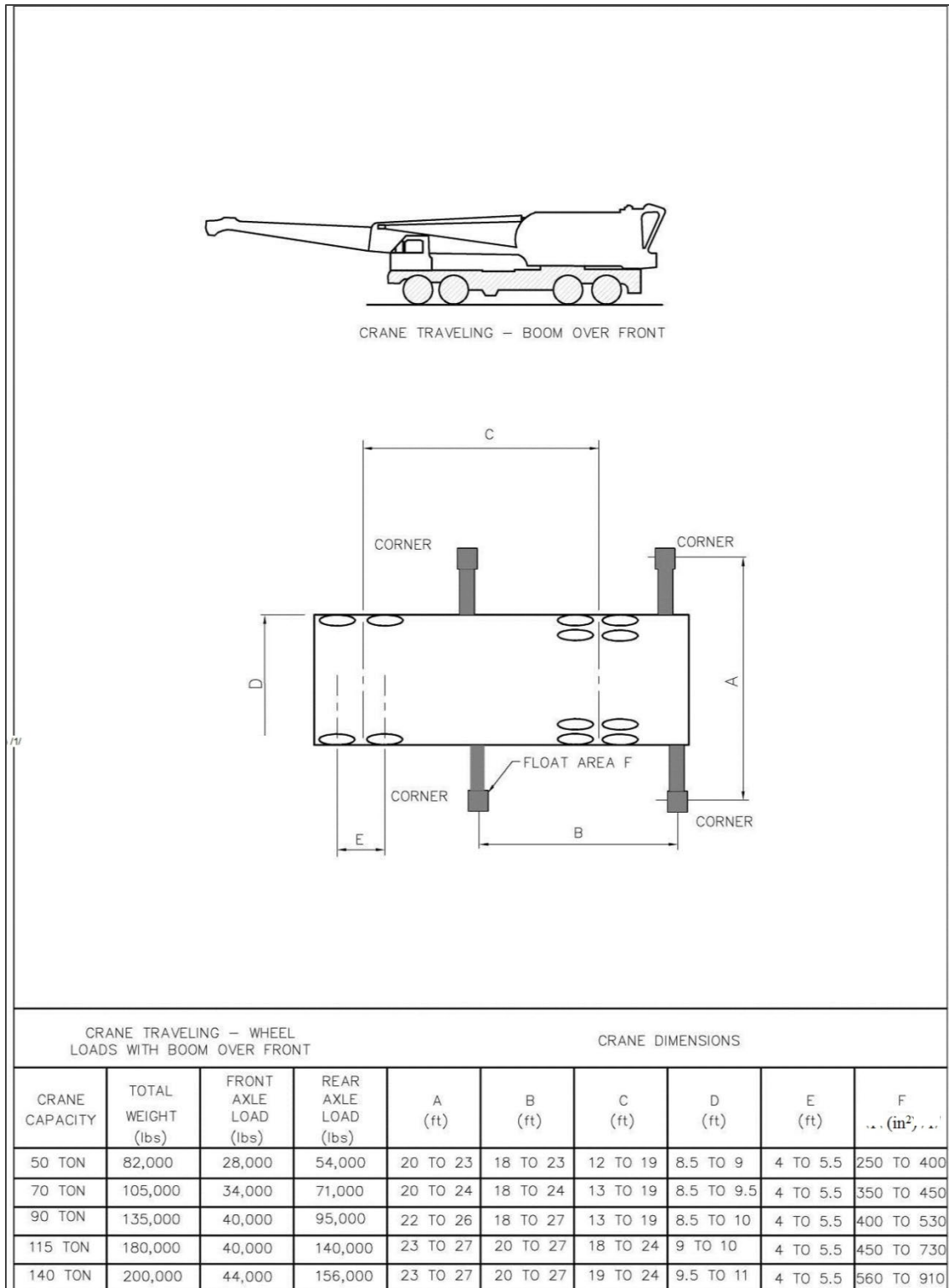

Table 3-3 Outrigger Float Loads for Mobile Cranes

Capacity	Radius	Boom Over Corner	Boom Over Back or Side (ea)
tons	ft	lbs	lbs
50	20 and less	97,000	89,000
	30	83,000	69,000
	40	78,000	60,000
	50 and more	72,000	55,000
70	20 and less	130,000	114,000
	30	115,000	90,000
	40	104,000	85,000
	50 and more	99,000	78,000
90	20 and less	160,000	144,000
	30	144,000	120,000
	40	130,000	107,000
	50 and more	117,000	98,000
115	20 and less	195,000	183,000
	30	180,000	151,000
	40	156,000	131,000
	50 and more	144,000	120,000
140	20 and less	232,000	207,000
	30	222,000	176,000
	40	211,000	164,000
	50	198,000	150,000
	60 and more	187,000	142,000

3-3.5.2 Outrigger Float Loads.

Table 3-3 lists outrigger float loads for different capacity cranes. The maximum single float load from a boom over corner position and maximum concurrent pair of float loads from a boom over side and back positions are listed. Typically, the float loads are at the maximum when lifting the rated load at a short radius (20 feet (6.1 m) and less) and should be used for design. However, for existing piers and wharves, the other listed loads may be used to analyze deck capacity. Typical outrigger float spacing is shown in Figure 3-4. Apply outrigger float loads to a 1.5 foot by 1.5 foot (0.46 m by 0.46 m) area unless actual float size is known, in which case use the actual float size for analysis.

3-3.5.3 Impact.

Apply an impact factor of 15 percent for all wheel loads when designing slab, beams, and pile caps. The impact factor need not be applied when designing for maximum outrigger float loads, piles and other substructure elements, filled structures, and where wheel loads are distributed through paving and ballast (1.5 foot (0.46 m) or more).

3-3.6 Forklift and Straddle Carrier Loadings.

3-3.6.1 Forklifts.

See Figure 3-5 for wheel loads from forklifts. Determine contact areas for wheel loads in accordance with AASHTO. For hard rubber wheels or other wheels not inflated, assume the wheel contact area to be a point load.

3-3.6.2 Straddle Carriers.

See Figure 3-6 for wheel loads for a straddle carrier. The straddle carrier shown is capable of lifting a loaded 20-foot (6.1 m) container or a loaded 40-foot (12.2 m) container.

3-3.6.3 Impact.

Apply an impact factor of 15 percent to the maximum wheel loads in the design of slabs, beams and pile caps. The impact factor need not be applied when designing piles and other substructure elements, when designing filled structures, and where wheel loads are distributed through paving and ballast (1.5 feet (0.46 m) or more).

3-3.7 Loading on Railroad Tracks.

For freight car wheel loads, use a live load of 8000 pounds per foot (117 kN/m) of track corresponding to Cooper E-80 designation of the American Railway Engineering Association (AREA) *Manual for Railway Engineering*. In the design of slabs, girders, and pile caps, apply an impact factor of 20 percent. Impact is not applicable for the design of piles and filled structures, or where loads are distributed through paving and ballast (1.5 feet (0.46 m) or more).

3-3.8 Buoyancy.

Typically, piers and wharf decks are not kept low enough to be subjected to buoyant forces. However, portions of the structure, such as utility trenches and vaults, may be low enough to be subject to buoyancy forces, which are essentially uplift forces applied at the rate of 64 psf (3064 kPa), for normal seawater at sea level, of plan area for every foot of submergence below water level.

3-3.9 Wave Loading.

For piers and wharves exposed to waves which may produce significant lateral or hydrostatic forces, determine wave loading in accordance with the procedures defined in UFC 4-150-06, *Military Harbors and Coastal Facilities*. Consider also that wave loading, may be vertical, resulting in uplift on the structure.

Figure 3-5 Wheel Loads for Forklifts

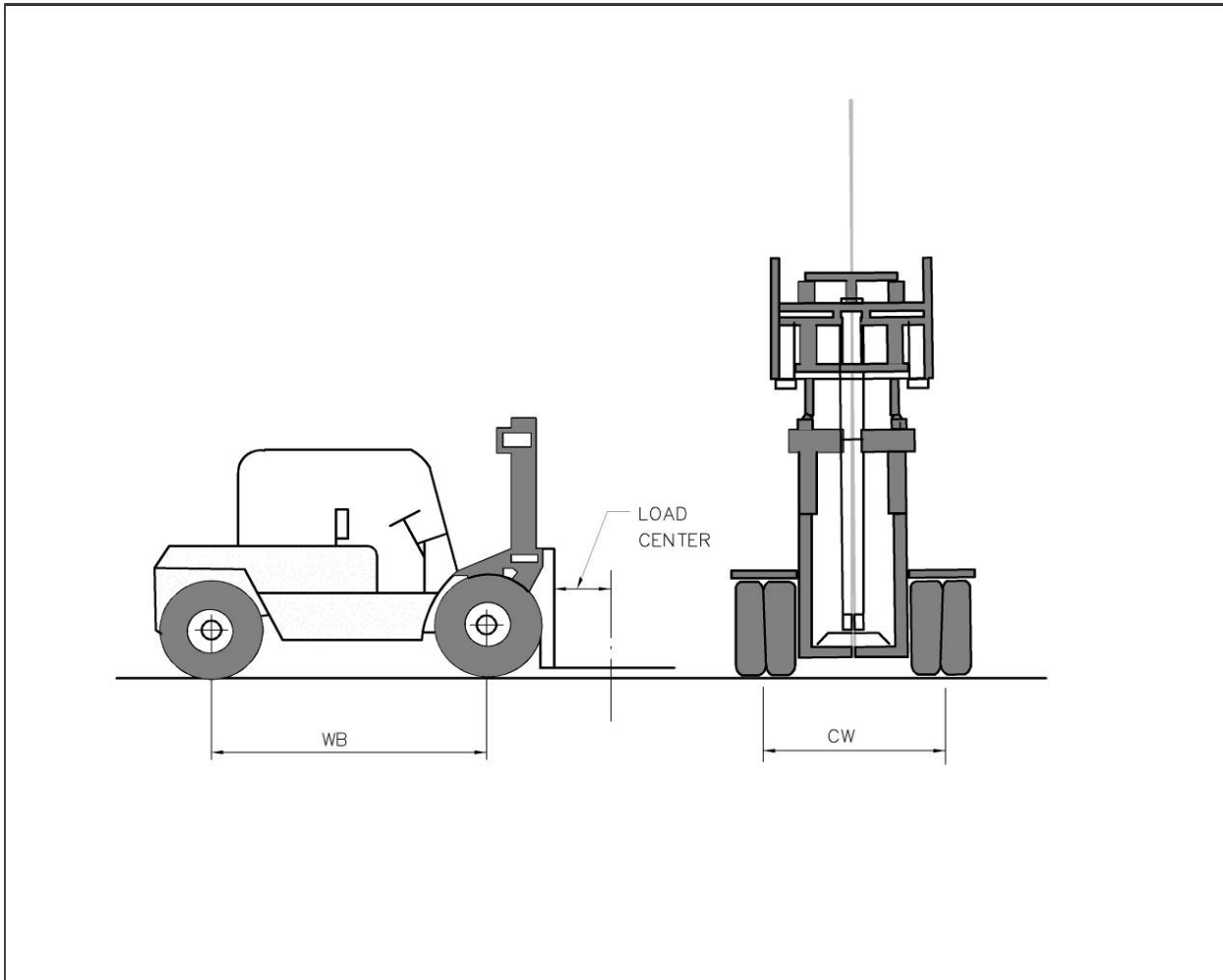

MAXIMUM LOAD (LBS)	LOAD CENTER (IN)	SERVICE WEIGHT (LBS)	TURNING RADIUS (FT.-IN)	WHEEL-BASE(WB) (FT.-IN)	WHEEL SPAC.(CW) (FT.-IN)	WHEEL LOADS (LOADED)	
						EACH REAR SINGLE TIRE (LBS)	EACH FRONT DUAL TIRE (LBS)
10,000	24	15,000	12-10	8-3	6-3	2,000	10,500
12,000	24	16,000	12-10	8-3	6-3	2,500	11,500
15,000	24	19,000	13-0	8-9	6-4	2,500	14,500
16,000	24	19,500	13-0	8-9	6-4	2,500	15,250
20,000	24	20,000	14-0	9-6	6-4	2,500	17,500
24,000	24	25,300	14-9	10-0	6-4	2,500	22,150
30,000	24	34,000	15-3	10-9	6-6	3,000	29,000
40,000	36	63,000	14-11	10-0	8-0	2,500	49,000

Figure 3-6 Wheel Loads for Straddle Carriers

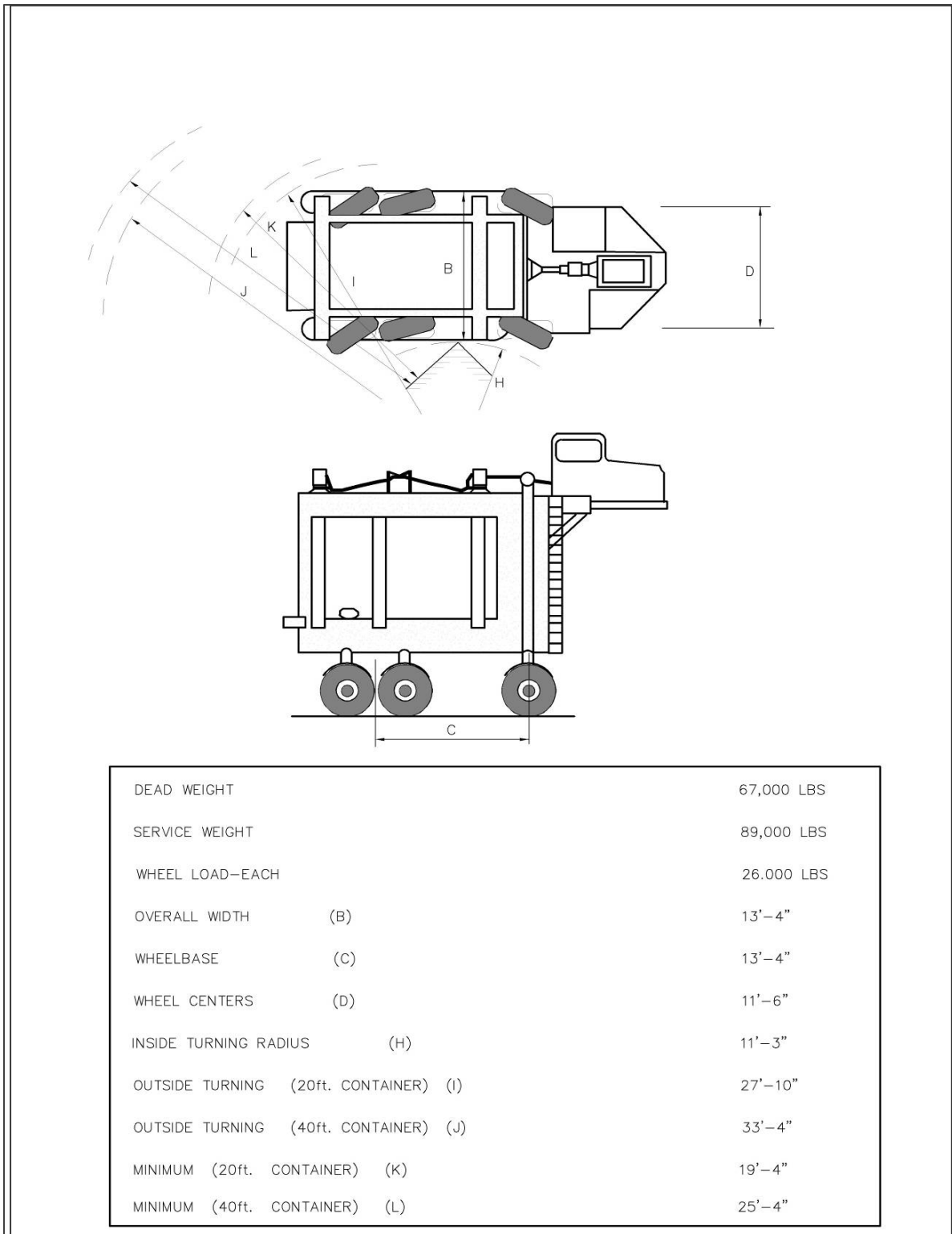

3-3.10 Application of Loadings.

3-3.10.1 Concentrated Loads.

Wheel loads and outrigger float loads from designated pneumatic-tired equipment, such as trucks, truck cranes, forklifts, and straddle carriers may be oriented in any direction and the orientation causing the maximum forces on the structural members should be considered for design. Significant loads from fuel containers (exceeding 300 kips (1334.5 kN)) at repair piers may be encountered. Design manhole covers and frames for pneumatic-tired equipment only. Design trench covers, utility trench covers, and access hatch covers to handle the concentrated loads, where they are accessible to mobile equipment. However, designated areas on the pier deck may be exempted from wheel loads or outrigger float loads, or designed for lesser loads, when curbs, railings, and other physical barriers are provided to isolate those areas from vehicle access. Concentrated wheel loads from these vehicles are applied through small "footprints" to the deck structure. The distribution of these loads and computation of maximum moments and shears may be in accordance with the AASHTO *Standard Specification for Highway Bridges*. However, this method is conservative and more reasonable results may be obtained using NCEL R-935, *Lateral Load Distribution on One-Way Flat Slab; Influence Surfaces for Elastic Plates*, for different edge conditions, or finite element analysis. Maximum mobile crane concentrated loads should not be combined with maximum wind, seismic, mooring or berthing loads.

3-3.10.2 Simultaneous Loads.

Apply uniform and concentrated live loads in a logical manner. Do not apply designated uniform live loadings and concentrated live loading from pneumatic-tired equipment simultaneously in the same area. However, apply uniform live load between crane tracks (for 80 percent of gage). When railroad tracks are present between crane tracks, apply track loads simultaneously. However, the maximum loads from each track need not be assumed. Unique operations may warrant a more conservative approach, i.e., during a "trans-shipment operation" (handling of fuel containers), there could be a portal crane straddling a railroad car loaded with a container, with another container sitting on the pier deck in the immediate vicinity.

3-3.10.3 Skip Loading.

For determining the shear and bending moments in continuous members, apply the designated uniform loadings only on those spans that produce the maximum effect.

3-3.10.4 Critical Loadings.

Concentrated loads from trucks, mobile cranes, forklifts, and straddle carriers, including mobile crane float loads, are generally critical for the design of short spans such as deck slabs and trench covers. Uniform loading, mobile crane float loading, rail-mounted crane loading, and railroad loading are generally critical for the design of beams, pile caps, and supporting piles.

3-4 HORIZONTAL LOADS.

3-4.1 Berthing Energy.

Procedures for calculation of berthing energy are found in the subsequent section: BERTHING ENERGY DETERMINATION of this UFC.

3-4.2 Mooring Loads.

Forces acting on a moored ship are produced by winds, currents, and waves. The determination of mooring loads involves an evaluation of many variables including: direction and magnitude of winds, currents, and waves; exposure of the berth; orientation of the vessel; number and spacing of mooring points; layout and type of mooring lines; tides; and the loaded condition of the vessel (light, one-third stores, fully loaded). In sheltered waters where piers and wharves are usually constructed, wave forces are not significant and may be ignored. Type III and Type IV mooring design requires 30-second gust, 50 and 100 year return period wind speed respectfully. The wind speed provided in UFC 3-301-01, *Structural Engineering* is a 3-second gust with a return period from 300 to 1,700+ years, depending upon the importance of the structure. Therefore, in order to attain the appropriate wind speed for mooring design of Type III and IV structures, a procedure is required for converting: the 3-second gust to a 30-second gust (referenced at a 33 feet (10.1 m) height above mean sea level), and for determining 50 year and 100 year Exposure D design winds. This is illustrated below for converting to a 50 year return period wind (associated with Mooring Service Type III):

Step 1: Convert 1700 year return period wind speed to 50 year return period wind speed.

$$V_{1700} = 124 \text{ mph (Naval Station Norfolk: Cat III-V; 1700 year return wind)}$$

$$V_{50-3sec} = V_{1700} / (0.36 + 0.1 * \text{LN}(12 * 1700)) = 92 \text{ mph (Peterka \& Schahid 1998)}$$

Step 2: Convert 3 second wind gust to a 30-second wind.

$$V_{50-30sec} = V_{50-3sec} / 1.175 = 78 \text{ mph (UFC 4-159-03 Fig 3-5, Hurricane Region)}$$

Step 3: Convert wind from Exposure C value to Exposure D.

$$V_{III} = V_{50-30} * \text{sqrt}(1.18) = 85 \text{ mph (74 knots) – Type III Mooring Design Wind}$$

Procedures for calculation of mooring loads are found in UFC 4-159-03, *Design: Moorings*. Local anchorage design of the mooring foundation shall exceed the working capacity of the fitting times the Mooring load factor for LRFD design. Global design of the pier or wharf is based on the demands from the mooring analysis (e.g. not all of the storm bollards will be engaged at one time).

3-4.3 Wind Loads on Structures.

Use UFC 3-301-01, *Structural Engineering* to provide minimum wind load on structures. Keep in mind that UFC 3-301-01 is based wind is a 3-second gust with a return period of 300 years or greater, thus wind on structure typically will not be combined with berthing, or mooring loads (e.g. vacant condition).

3-4.4 Loads on Piles.

In addition to the axial loads, bending moments, and shears caused by lateral loads at deck level due to berthing, mooring and seismic forces, piles are also subjected to other types of lateral loads acting along the length of the pile. Keep in mind that, in areas having large tidal ranges, lateral loads are applied much lower than the deck elevation creating significant shear and flexural stresses in the piles.

3-4.4.1 Current and Waves.

These loads are applied at and near the water level and may be significant where large size piles are used in high-current waters. An estimate of current and wave forces can be made using the UFC 4-150-06, *Military Harbors and Coastal Facilities*.

3-4.4.2 Sloping Fill Loads.

These loads are transmitted along the shaft of the piles by the lateral movement of the soil surrounding the piles beneath the structure, such as may occur along a sloping shoreline at marginal wharves, as shown in Figure 2-9. The maximum moments in the piles for this category of loading are determined by structural analysis and the methods outlined in UFC 3-220-01, *Geotechnical Engineering*, after the conditions of pile support in the pile cap and the soil have been established and the effective length of pile has been determined.

Piles of relieving platform types of solid wharves, shown on Figure 2-10, may be subjected to lateral earth loads if the stability of the slope beneath the platform is minimal and soil creep occurs. In such cases, stabilizing measures should be introduced, prior to installation of piles, to prevent movement of the soil along the slope. Among the stabilizing measures that may be used are surcharging (preloading), installation of sand drains or soil compaction piles, or replacement of unstable materials. If the piles supporting the structure are used to increase slope stability, or if time-dependent stabilizing measures are introduced after the piles are in place, calculate the resistance to soil movement provided by the piles and the piles checked for the bending moments induced by the calculated lateral earth loads, in addition to the increased loading caused by the downdrag of the settling soil.

The pile resistance to soil movement may be obtained from a stability analysis by determining the additional resistance, provided by the piles, which will provide a factor of safety that corresponds to zero soil movement. The minimum factor of safety required for this type of analysis varies and should be selected after evaluating the soil conditions, which exist at the site. The embedment length of piles needed for

developing the required lateral resistance may be determined in accordance with the criteria given in UFC 3-220-01, *Geotechnical Engineering*.

3-4.4.3 Pile Driving Loads.

Piles are subjected to high compressive and tensile stresses during driving and should be proportioned to resist these in addition to the service loads. Where prolonged driving in alternately soft and hard layers of soil or driving through stiff "quaky" clays is anticipated, very high tensile stresses are set up and will require a higher level of effective prestress (1000 psi (6895 kPa) or more) in prestressed concrete piles. Give attention to controlling driving stresses by specifying frequent cushion replacement, and by requiring use of hammers capable of adjusting driving energy.

3-4.5 Loads on Utilities.

Utilities should be located above pier deck. It is important to keep utilities high above the water level and preferably protected in trenches. In some cases utilities are located under the pier deck and are therefore, more susceptible to damage from wind, wave, current, and impact from debris. Regardless of utility location, consider environmental loads, e.g. wind, wave, current. In evaluating these loads, consideration must also be given to the appropriate water level. An estimate of current and wave forces can be made using the UFC 4-150-06, *Military Harbors and Coastal Facilities*.

3-4.6 Earthquake Loads.

Use the procedures and methods contained in ASCE/COPRI 61-14 *Seismic Design of Piers and Wharves*, hereafter known as ASCE 61, for seismic design of Piers and Wharves unless otherwise directed herein. Note that the ASCE 61 committee made a conscious decision to reference ASCE 7-05 throughout and not to include ASCE 7-10, mainly because ASCE 7-10 was published after the ASCE/COPRI 61-14 had been prepared. The ASCE 61 committee will reconsider referencing the most recent version of ASCE 7 in future versions.

3-4.6.1 Design Approach:

Use the design approach from Section 3.4 of ASCE 61 as modified below unless approval for an alternative approach is obtained from the approving authority.

- a. Define the Design Classification in accordance with Table 3-4.
- b. Determine which performance levels along with associated hazard levels need to be satisfied per ASCE 61 Table 2-1.
- c. Determine the design method per 3-4.6.3.
- d. Base definition of ground motion for Design Earthquake (DE) on the procedures in ASCE 7-10, see 3-4.6.4.
- e. Determine soil/structure modeling parameters (p-y and t-z springs) per ASCE 61 Sections 4.8 and 4.10.

- f. Determination of other special geotechnical considerations or loads in ASCE 61 Chapter 4.
- g. Development of the structural model, including general modeling considerations of ASCE 61 Section 3.7.
- h. Calculations of structural demands per ASCE 61.
- i. Calculation of structural capacity per ASCE 61.
- j. Development of connection details per ASCE 61 Chapter 7.
- k. Design of ancillary components per ASCE 61 Chapter 8.

3-4.6.2 Design Classification.

Table 3-4 Seismic Design Classifications

Classification	Pier/Wharf
High ^a	Ammunition Fueling Supply Explosive Handling General Purpose Berthing Repair Magnetic Silencing Access Trestle Deep Water Bulkhead
Moderate ^b	
Low	Inactive Berthing Cargo Staging Area Shallow Water Bulkhead Seawalls and Riprap Fleet Landing Small Craft Berthing Small Craft Boat Ramp

^a Only consider Operating Level Earthquake when S_{DS} exceeds 0.33

^b Site/project specific considerations may dictate moderate versus high or low classification

3-4.6.3 Determine Seismic Analysis Procedure:

- a. Non-linear time history analysis should be considered for high value national assets such as Explosive Handling Wharves when warranted.
- b. Displacement-based design is permitted for all design classifications.
- c. Force-based design is permitted for “low” design classifications per Table 3-4.
- d. Force-based design is permitted for all design classifications when $S_{DS} < 0.33$
- e. Force-based design is permitted for all design classifications where it can be demonstrated that the capacity of all primary structural members exceeds the elastic earthquake demand when using a value of $R = 1.0$.
- f. Force-based design is permitted for the design of equipment, piping supports, and minor structures.

- g. Allowable stress design (ASD) is permitted for geotechnical design of shallow and deep foundations when the soils report does not contain LRFD soils values.

3-4.6.4 Design Spectra.

In the absence of a site specific ground motion study reference tables from UFC 3-301-01, *Structural Engineering* for Design Earthquake (DE), 10/50 and 20/50 spectral acceleration values. For structures with a High Performance Level and $S_{DS} > 0.33$, use the following equation to determine the spectral acceleration values associated with ground motion with a probability of exceedance of 50% in 50 years (72 year return period):

The spectral acceleration values for earthquakes with a 2 and 10% probability of exceedance in a 50-year period are typically well defined. To obtain seismic spectral accelerations for other recurrence intervals use the following formula based upon the procedure presented in Section 1.6.1.3 of FEMA 356, *Prestandard and Commentary for the Seismic Rehabilitation of Buildings*.

$$S_i = S_{i(10/50)} (C_i)$$

where:

- S_i = Spectral acceleration parameter (“ i ” = “s” for short-period, or “ i ” = “1” for 1-second period)
- $S_{i(10/50)}$ = Spectral acceleration parameter (“ i ” = “s” for short-period, or “ i ” = “1” for 1-second period) at a 10 % probability of exceedance in 50 years
- C_i = Modifier provided in Tables 3-5 and 3-6 below (“ i ” = “s” for short-period, or “ i ” = “1” for 1 second period).

Table 3-5 Values of C_s , Modifier for Short-Period Spectral Acceleration

Design Earthquake Probability of Exceedance in 50 Years

Region	10%	15%	20%	50%	65%	75%
California	1.0	0.83	0.72	0.44	0.36	0.32
Pacific Northwest	1.0	0.79	0.67	0.36	0.29	0.25
Eastern US	1.0	0.72	0.56	0.23	0.17	0.14
Other locations	1.0	0.79	0.67	0.36	0.29	0.25

Notes:

1. The modifier C_s includes a statistical adjustment factor, “ P_R ”, and a location adjustment factor, “ n ”, as defined in section 1.6.1.3 in FEMA 356, *Prestandard and Commentary for the Seismic Rehabilitation of Buildings*, Nov. 2000. The value of “ n ” is taken as 0.54 for locations outside of the continental US.
2. This table is valid at locations where the Mapped MCE spectral acceleration for short-periods, S_s , is less than 1.5g.

Table 3-6 Values of C_1 , Modifier for 1-Second Period Spectral Acceleration

Design Earthquake Probability of Exceedance in 50 Years

Region	10%	15%	20%	50%	65%	75%
California Pacific Northwest	1.0	0.83	0.72	0.44	0.36	0.32
Eastern US	1.0	0.77	0.64	0.33	0.26	0.22
Other locations	1.0	0.71	0.55	0.22	0.16	0.13
	1.0	0.77	0.64	0.33	0.26	0.22

Notes:

1. The modifier C_1 includes a statistical adjustment factor, " P_R ", and a location adjustment factor, " n ", as defined in section 1.6.1.3 in FEMA 356, *Prestandard and Commentary for the Seismic Rehabilitation of Buildings*, Nov. 2000. The value of " n " is taken as 0.59 for locations outside of the continental US.
2. This table is valid at locations where the Mapped MCE spectral acceleration for short-periods, S_s , is less than 1.5g.

3-4.6.5 Dynamic Fill Loads.

In general, piles subjected to seismic forces behave as flexible members and their behavior is controlled primarily by the surrounding soil. Both vertical and batter piles move together with the surrounding soil during an earthquake. Provided that shear failure or liquefaction of the surrounding soil does not occur during ground shaking, the pile-supported structure will move a limited amount and remain stable after an earthquake. The magnitude of the horizontal movement depends on the earthquake magnitude and duration, design details of the platform, flexibility of the piles, and the subgrade modulus of the foundation soil. If the soil surrounding the piles is susceptible to liquefaction or if slope failure occurs, the piles will move excessively, resulting in serious damage to the piles and the structure. For these conditions, remove and replace unstable materials. When the piles penetrate a deep soft layer first and then a stiff layer of soil, the soils displace cyclically back and forth during an earthquake. During the cyclic ground shaking, the piles will move with the ground and return essentially to their original position if the soil does not fail during these cyclic displacements. Accordingly, if piles are to continue to safely support loads after an earthquake, it will be necessary for the piles to have the capability to withstand the induced curvature without failure.

3-4.6.6 Embankments and Fills.

For determining the stability of embankments and fills at solid wharves, when subjected to earthquake forces, refer to UFC 3-220-01, *Geotechnical Engineering*, NCEL TR-939, *The Seismic Design of Waterfront Retaining Structures* and NCHRP Report 611, *Seismic Analysis and Design of Retaining Walls, Buried Structures, Slopes, and Embankments*.

3-4.6.7 Floating Structures.

Usually, floating structures are not directly affected by seismic events. However, waves created by offshore seismic activity such as a seiche or tsunami will affect floating structures. Also, the mooring system employed (spud piles and chain) will be subjected to the ground motions and should be investigated.

3-4.6.8 Earthquake Induced Hydrodynamic Loads.

Refer to STANDARD 61 Section 3.7.3 “for 24 in. and smaller piles hydrodynamic mass may be ignored.” For larger piles include the hydrodynamic water mass inside and outside of the pile/structure in accordance with STANDARD 61 Section 3.7.3.

3-4.6.9 Crane Wharf Interaction.

Refer to STANDARD 61 Sections 3.7.3 and 8.5.2. “The mass of container cranes shall be determined in accordance with Section 8.5.2 and distributed over the length of the pier or wharf.”

3-4.6.10 Dry Docks.

Refer to MIL-STD 1625D (SH) *Safety Certification Program for Dry docking Facilities and Shipbuilding Ways for U.S. Navy Ships* as it relates to seismic requirements for dry docks. Reference requires that a new seismic analysis be performed for dry docks and specifies design earthquake levels and performance criteria. Method(s) of performing analysis is currently under development by NAVFAC EXWC.

3-4.7 Earth and Water Pressures on Retaining Structures.

Consider the effects of tidal lag, overdredging, the potential for dredge depth increases to accommodate deeper draft vessels, and sloughing of fill.

3-4.7.1 Static Case.

Static earth pressures, acting on retaining structures, are determined in accordance with the criteria detailed in UFC 3-220-01, *Geotechnical Engineering*.

3-4.7.2 Dynamic Case.

Seismic forces may cause increased lateral earth pressures on earth retaining wharf structures accompanied by lateral movements of the structure. The degree of ground shaking that retaining structures will be able to withstand will depend, to a considerable extent, on the margin of safety provided for static loading conditions. In general, wharf retaining structures, designed conservatively for static loading conditions, may have a greater ability to withstand seismic forces than those designed, more economically, by less conservative procedures. Methods for determining lateral earth pressures due to seismic forces are discussed in UFC 3-220-01, *Geotechnical Engineering*, NCEL TR-939, *The Seismic Design of Waterfront Retaining Structures* and NCHRP Report 611,

Seismic Analysis and Design of Retaining Walls, Buried Structures, Slopes, and Embankments.

3-4.7.3 Water Pressure.

Consider pressures due to water level differentials, resulting from tidal fluctuations (tidal lag) and/or groundwater accumulations, in the design of sheet pile bulkheads, cells, and curtain walls, and in stability investigations for embankments and fills. Consider additional loading due to hydrodynamic pressure for retaining structures as addressed in UFC 3-220-01, *Geotechnical Engineering*.

3-4.8 Thermal Loads.

3-4.8.1 Temperature Differential.

The effect of thermal forces that build up in the structure due to fluctuations in temperature will vary from those measured at the time of construction. For piers and wharves, the large body of adjacent water has a substantial moderating effect on the structure. Consequently, the structure may not attain an overall temperature 10 to 20 °F (5.6 to 11.1 °C) higher or lower than the water temperature. The effect will be even less for ballasted deck construction (5 to 10 °F (2.8 to 5.6 °C) higher or lower than water temperature). However, unballasted decks may see a large temperature differential through depth. Consult with AASHTO for recommended thermal gradients over water. Solid-type piers and wharves and floating structures are not likely to be affected by temperature variations.

3-4.8.2 Pile-Supported Structures.

Typically, decks of pile-supported structures will be subjected to temperature differential. However, since the axial stiffness of the deck elements will be much higher than the flexural stiffness of piles, the deck will expand or contract without any restraint from piles (for narrow marginal wharves, the short inboard piles may offer some restraint, and hence need to be analyzed) and will subject the piles to bending moments and shear forces. Locate batter piles so as not to restrain thermal motion (usually in the middle portion of a long structure).

3-4.9 Ice Forces.

In addition to the weight of accumulated ice on the structure, consider the forces exerted by floating ice. The principal modes of action of floating ice are shown in Figure 3-7 and discussed below.

Figure 3-7 Principal Modes of Ice Action

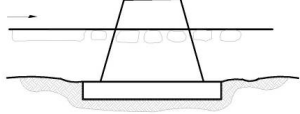
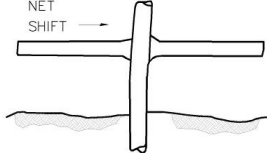
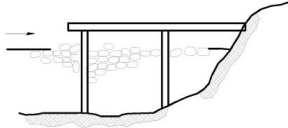
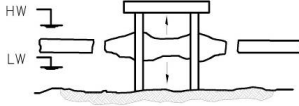
NO.	DESCRIPTION	TYPICAL ENVIRONMENT	ILLUSTRATION
1	IMPACT OF MOVING SHEETS AND FLOES.	RIVERS AT BREAK-UP, COASTAL WATERS WITH APPRECIABLE CURRENTS	
2	STATIC PRESSURE FROM EXPANDING OR CONTRACTING SHEETS.	LAKES, SHELTERED COASTAL WATERS. TEMPERATURE CHANGES AND JACKING BY REFREEZING OF CRACKS.	
3	SLOW PRESSURE FROM ICE PACK OR JAM.	EXPOSED COASTAL WATERS, RIVERS.	
4	VERTICAL MOVEMENT	TIDAL LOCATIONS WITH HEAVY ICE BUILD-UP.	

3-4.9.2 Dynamic Impact.

Follow the criteria in the AASHTO standard to the extent feasible. For lightly loaded structures and for open pile platforms, these criteria may result in structures of unreasonable proportions. In such cases, consider reducing the AASHTO criteria in accordance with *CSA-S6 Canadian Highway Bridge Design Code*. See AASHTO *Dynamic Ice Forces on Piers and Piles*. The values of effective pressure are:

- AASHTO 400 psi (2,758 kPa)
- CSA-S6 100 to 400 psi (689 to 2,758 kPa) (highway bridges)
- CSA-S6 200 to 250 psi (1,379 to 1,724 kPa) (wharf piles)

3-4.9.3 Static Pressure.

Freshwater ice will exert less pressure on a structure than seawater ice of the same thickness. For freshwater ice, assume pressures of 15 to 30 psi (103 to 207 kPa). For sea ice, pressures of 40 psi (276 kPa) to as much as 150 psi (1,034 kPa) may be assumed. These are maximum values and relate to crushing of the ice. If the ice sheet can ride up on the nearby shore, the pressure exerted will be less than if the ice sheet is confined within vertical boundaries.

3-4.9.4 Slow Pressure.

Broken ice flows will exert less pressure than a solid ice sheet. In general, the pressures developed in this mode of action will be less than those experienced under the static pressure mode of action. Reliable values of pressure are not presently available.

3-4.9.5 Vertical Movement.

Assume that the structure will lift or depress a circular sheet of ice. Calculate the radius of the affected ice sheet on the basis of the flexural strength of ice as 80 to 200 psi (552 to 1,379 kPa). Check the shear on the basis of the strength (and adhesion) as 80 to 150 psi (552 to 1,034 kPa). Consider the formation of bustle (added thickness) of ice around the structure. See *AASHTO Ice Pressure on Engineering Structures*.

3-4.10 Shrinkage.

Open pier and wharf decks, which are usually constructed from concrete components, are subject to forces resulting from shrinkage of concrete from the curing process. Shrinkage loads are similar to temperature loads in the sense that both are internal loads. For long continuous open piers and wharves and their approaches, shrinkage load is significant and should be considered. However, for pile-supported pier and wharf structures, with cast-in-place concrete pile caps and decks, the effect is not as critical as it may seem at first because, over the long time period in which the shrinkage takes place, the soil surrounding the piles will slowly "give" and relieve the forces on the piles caused by the shrinking deck. The PCI Design Handbook (section 7.3.1.1) and ACI 209.2R 08, *Guide for Modeling and Calculating Shrinkage and Creep in Hardened Concrete* are recommended for design.

3-4.11 Creep.

This is also a material-specific internal load similar to shrinkage and temperature and is critical only to prestressed concrete construction. The creep effect is also referred to as rib shortening and should be evaluated using the *PCI Design Handbook*.

3-5 LOAD COMBINATIONS.

3-5.1 General.

Proportion piers and wharves to safely resist the load combinations represented by Tables 3-7 and 3-8. Analyze each component of the structure and foundation elements for all the applicable combinations.

3-5.2 Load Symbols.

The following load symbols are applicable for Table 3-7 and Table 3-8:

D = Dead load

L_u	= Live load (uniform)
L_c	= Live load (concentrated)
I	= Impact load (for L_c only)
B	= Buoyancy load
H	= Loads due to lateral earth, ground water, or pressure of bulk material
B_e	= Berthing, for Accidental Berthing see section: Accidental Berthing
C	= Current load on structure
EQ	= Earthquake load
k	= 50% of Peak Ground Acceleration (PGA)
k'	= $0.7k = (0.7)(0.5)PGA = (0.35)PGA$
W	= Wind or wave load on structure
M	= Mooring/Breasting load
R	= Creep/rib shortening
S	= Shrinkage
T	= Temperature load
Ice	= Ice load (includes snow load)

3-5.3 Load and Resistance Factor Design (LRFD).

Load combinations are presented in Table 3-7. For load cases not listed consult IBC Section 1605.2.

3-5.4 Service Load Design/Allowable Stress Design (ASD).

Load combinations are presented in Table 3-8. For load cases not listed consult IBC Section 1605.3.

Table 3-7 Load Combinations - Load and Resistance Factor Design (LRFD)

Load	U0	U1	U2	U3	U4	U5	U6	U7	U8	U9
D^a	1.4	1.2	1.2	1.2	1.2	1.2	1.0+k	1.0-k	1.2	1.2
(L_c+I) L_u	-	1.6 ^b	-	1.6 ^b	-	1.6 ^b	0.1	-	1.6 ^b	1.0
B	1.4	1.2	1.2	1.2	1.2	1.2	1.2	0.9	1.2	1.2
Be	-	-	1.6 ^c	-	-	-	-	-	-	-
C	-	-	1.2	1.2	1.2	1.2	-	-	-	1.2
H^d	-	1.6	1.6	1.6	1.6	1.6	1.0	1.0	1.6	1.6
Eq	-	-	-	-	-	-	1.0	1.0	-	-
W	-	-	-	-	1.0	-	-	-	-	1.0
M	-	-	-	-	-	1.6	-	-	-	-
R+S+T	-	-	-	1.2	-	-	-	-	-	-
Ice		-	-	0.5	-	-	-	-	1.0	1.0

Table 3-8 Load Combinations - Allowable Stress Design (ASD)

Load	S0	S1	S2	S3	S4	S5	S6	S7	S8	S9
D^a	1.0	1.0	1.0	1.0	1.0	1.0	1+k'	1-k'	1.0	1.0
(L_c+I) L_u	-	1.0	-	1.0	-	1.0	0.1	-	1.0	0.75
B	1.0	1.0	1.0	1.0	1.0	1.0	1.0	0.6	1.0	1.0
Be	-	-	1.0	-	-	-	-	-	-	-
C	-	-	1.0	1.0	1.0	1.0	-	-	1.0	1.0
H^d	-	1.0	1.0	1.0	1.0	1.0	1.0	1.0	1.0	1.0
Eq	-	-	-	-	-	-	0.7	0.7	-	-
W	-	-	-	-	0.6	-	-	-	-	0.6
M	-	-	-	-	-	1.0	-	-	-	-
R+S+T	-	-	-	1.0	-	-	-	-	-	-
Ice	-	-	-	0.2	-	-	-	-	0.7	0.7

Notes:

- ^a 0.9 (0.6 ASD) for checking members for minimum axial load and maximum moment.
- ^b 1.3 for the maximum outrigger float load from a truck crane.
- ^c Accidental Berthing: 1.2 support structure, 1.0 fender system components.
- ^d Where the effect of H resists the primary variable load effect, a load factor of 0.9 (0.6 for ASD) shall be included with H where H is permanent and H shall be set to zero for all other conditions.

This Page Intentionally Left Blank

CHAPTER 4 STRUCTURAL DESIGN

4-1 CONSTRUCTION MATERIALS.

4-1.1 Timber.

For the major functional types of piers and wharves such as ammunition, berthing, repair, and supply facilities subject to high concentrated wheel loads, timber construction should not be considered. Timber may be more effective and optimal for fender systems, dolphins, walkways, utility trays, and deck-supported small buildings. For light-duty piers and wharves, such as fueling, temporary, and Magnetic Treatment and Electromagnetic Roll piers, timber framing for deck and piling may be considered. Consult with the local activity and Facilities Engineering Command (FEC) for local requirements and restrictions on the use of treated timber. Obtaining permits for treated timbers, especially creosoted fender pile, is becoming very difficult in various areas of the country.

4-1.1.1 Preservative Treatment.

All timber members, with the exception of some fender piling, exposed to the marine environment and immersed in salt water or fresh water should be pressure treated. Per AWWA UC5C, treatment with CCA or ACZA in accordance with Best Management Practices is acceptable. Treat with waterborne (salts) chemical preservatives to protect against deleterious effects of decay, insects, and marine borers. In warmer waters, where severe marine borer activity can be anticipated, treat with salt. Consult the staff entomologist at the cognizant FEC for specific information on marine organisms present and the treatment required.

If possible, make pressure treatment after all holes and cuts are made. When holes and cuts are made in the field, treat timber members with preservative to prevent decay from starting in the holes or cuts. Consult a staff entomologist for the proper preservative. Field treatments are difficult in the tidal zone and are typically not very effective against marine borers. Therefore, whenever possible, design and detailing should avoid the necessity for making cuts or holes on underwater timber members. For example, avoid bracing or connections below mean high water. All connection hardware should be suitable for the saltwater exposure. For above water construction, waterborne salt treatment is preferable to creosote treatment due to the staining effect that creosote treatment produces.

4-1.1.2 Timber Species.

Douglas fir and southern pine are the most popular species for waterfront construction. Southern pine piles are limited to 65 feet (19.8 m) in length, whereas Douglas fir piles and poles can be used in up to 100-foot (30.5 m) lengths. Large beams and timber sizes needed for chocks and wales are generally available only in Douglas fir and southern pine. Treat chocks and wales with waterborne salts and not oilborne

preservatives such as creosote. Evaluate the cost and availability of timber piles and other members for the project.

4-1.2 Steel.

When protected against corrosion by the use of coal tar epoxy or other marine coatings and cathodic protection systems, steel construction may be considered for all types of marine structures. Active cathodic systems are difficult to design, construct, and maintain properly, therefore, passive systems are preferred. UFC 3-570-01, *Cathodic Protection* provides criteria regarding cathodic protection system design. Additional steel thickness may be provided as a sacrificial corrosion allowance. Steel is particularly adaptable for use: in template and jack-up barge construction at advance base facilities; as piles for structures located in deep water where high lateral forces exist; as fender piles and fender panels; as piles for structures located in areas of high seismic activity; and where difficult driving is anticipated. When the utilization of other construction materials is considered feasible, the use of steel construction may be restricted due to cost and maintenance considerations.

Coating of structures and materials in the harsh marine environment is of the utmost importance, particularly in the area known as the splash zone. The "Splash Zone" is defined as the area between the year's lowest tidal mark and up to ten feet above the year's highest tidal mark. An earlier generation coating was developed formulated from polysulfide modified novolac epoxy. This was renamed Zero VOC, Coal Tar Free Splash Zone Coating (SZC). SZC is expected to provide at least "twice" the performance compared to the currently specified coating systems. ESTCP Project WP-200528 Zero VOC, Coal Tar Free Splash Zone Coating (SZC), Final Report provided a full scale validation of the SZC for use as an in-service waterfront maintenance system and enables the transition of this coal tar free coating directly into the hands of DOD end users who require waterfront metal (e.g., sea walls, sheet pile) maintenance painting. Further, this project addressed performance and environmental requirements for sustainment and reduction of VOC and HAP emissions due to the SZC being free of toxic metals, hazardous air pollutant free, contains no coal tar pitch, and has zero VOC's.

4-1.3 Concrete.

For piers and wharves, concrete is generally the best material for construction. Properly designed and constructed facilities are highly durable in the marine environment. New advances in concrete technology have improved concrete durability. Concrete enhanced with fly ash and corrosion inhibitors has demonstrated superior performance and should be used whenever possible. UFGS 03 31 29, *Marine Concrete* contains the latest developments in marine concrete. Caution should be exercised when using silica fume considering the guidance and precautions contained in the UFGS. Concrete is also ideal for deck construction in open-type piers and wharves and, when properly designed, is more economical for floating structures. Proprietary stainless steel reinforcement bars, wires, and strands have been developed for use in concrete construction where nonmagnetic properties are desired as in Magnetic Treatment and

Electromagnetic Roll piers. In contrast to new concrete, repair concrete requires different considerations in terms of design, materials, construction and quality control. In this regard, TR-NAVFAC-EXWC-CI-1304 *Enhanced Guidelines for Marine Concrete Repair*, has been prepared documenting some of the key considerations for marine concrete repair and pointing to the need of a dedicated UFGS. Three primary advancements to be contained in the specification include: enhance quality control/quality assurance, use of embedded galvanic anodes, and use of form and pressure pump repair methods. Consider protection of the concrete reinforcement from corroding to all construction located in a spray zone, not only to partially submerged construction, but to concrete in a dry-wet zone. Consider achieving concrete densification using a fly ash as substitute in a concrete matrix and / or utilization of the cementitious epoxy coating for protection of the concrete and structural steel in the dry-wet zone.

4-1.3.1 Precast Concrete Piles.

Precast concrete piles should preferably be prestressed to resist the tensile forces frequently encountered during driving. Corrosion of reinforcement in prestressed concrete piles can be controlled by proper mix design and, in extreme cases, by epoxy coating the reinforcement. However, exercise sufficient control during driving of concrete piles to minimize cracking. Where difficult driving into very compact sands, gravels, or rock is anticipated, the tip of the piles may be equipped with a WF-shape or H-pile "stinger" to achieve needed penetration. Exercise caution when selecting the material for an internal jet pipe in solid precast piles. There have been issues on some projects during pile driving when plastic/PVC is used for the internal jet pipe. Issues arise when concrete piles are driven and jetted at the same time in clayey soils. The clays can clog the jet pipe resulting in water hammer. The plastic/PVC jet pipes tend to crack under these conditions resulting in cracks forming in the concrete pile.

Very large hollow cylindrical piles (48-inch (1.2 m) diameter and larger) have also been successfully employed for waterfront construction on the East coast. However, longitudinal cracking was encountered with these same types of piles during construction of Pier D at Bremerton, Washington. Recently, proprietary carbon fiber pre-stressing and post tension strands have come into the market. These strands could have future applications such as for Magnetic Treatment and Electromagnetic Roll piers.

4-1.4 Composites.

Composites made of concrete and steel, concrete and fiberglass, plastic and fiberglass, and plastic and steel have been successfully employed in piers and wharves. Composites offer many advantages over conventional materials but often have limitations that need to be considered. Some advantages may include improved corrosion resistance, lightweight, and ease of construction. Some of the disadvantages may include low strength, UV light deterioration, long-term durability and high cost.

4-1.4.1 Concrete and Steel.

Concrete-filled pipe piles, steel H-piles with a concrete casing, and steel beams with concrete decks are the more common composite types. The concrete casing or jacket for the steel H-piles may be required only in the splash or tidal zone. However, due to instances of severe deterioration of the pile just below the jacket, extend the jacket to Extreme Low Water (ELW) or to below mudline. Concrete may also be added to steel pipe piles for deadweight purposes to resist uplift forces or to increase the stiffness of the pile.

4-1.4.2 Concrete and Fiberglass.

Concrete-filled fiberglass piles have been used in facilities where high axial capacities are not required. The lightweight fiberglass piles are easily installed and do not require high capacity handling equipment.

4-1.4.3 Plastic and Fiberglass.

Fiberglass reinforced plastic piles and beams have been successfully used in pier and wharf construction primarily as fender piles, wales and chocks.

4-1.4.4 Plastic and Steel.

Recycled plastic piles with steel cage reinforcement have also been used in pier and wharf construction.

4-1.5 Aluminum.

For deck-supported structures and for support of piping and conduits, aluminum members are useful. However, do not use unprotected aluminum underwater or in the splash zone. To prevent corrosion, aluminum should be electrically isolated from adjacent materials by nonconductive gaskets, washers, or bolt sleeves. Aluminum construction may be used in the superstructure of Magnetic Treatment and Electromagnetic Roll piers, due to the nonmagnetic characteristics of the material.

4-1.6 Plastics.

Fiberglass-reinforced plastics (FRP), ultra-high molecular weight (UHMW) plastics, and high-density polyethylene (HDPE) are being increasingly used in waterfront construction. FRP grating and shapes are highly durable in the marine environment when shielded from ultraviolet rays. UHMW plastics are useful in fender systems design as rub strips where a high abrasion resistance and low coefficient of friction are required. UHMW plastics are available in various grades. The use of corrosion-resistant FRP components including reinforcing bars, prestressing tendons, structural shapes, and unidirectional or woven fabrics, are being developed and have been successfully used in the repair of piers and wharves. Consider using these materials when the situation warrants, but give special attention to the design of connections.

Carefully evaluate the use of FRP components as structural elements for new construction.

4-2 ALLOWABLE STRESSES.

4-2.1 General.

Allowable stresses for materials used in pier and wharf construction generally conform to industry standard codes for the type of material and the purposed application unless modified herein. Allowable stresses for fender system design are discussed in section: FENDER SYSTEMS.

4-2.2 Timber.

Design timber structural elements in accordance with UFC 1-200-01, *DoD Building Code (General Building Requirements)*. Allowable stresses are generally not affected by preservative treatment. However, modulus of rupture and modulus of elasticity are considerably reduced by preservative treatment. When preservative treatment for fire retardation is used, consult the National Design Specification (NDS) for reductions in allowable stresses.

4-2.3 Steel.

Design steel structural elements in accordance with UFC 1-200-01, *DoD Building Code (General Building Requirements)*.

4-2.4 Castings.

Design cast steel and cast iron mooring fittings with the following minimum factors of safety (FS), Minimum FS towards yield = 2.0, Minimum FS towards fracture = 3.0.

4-2.5 Concrete.

Design concrete structural elements in accordance with UFC 1-200-01, *DoD Building Code (General Building Requirements)*. For prestressed concrete members, “zero” tension design is preferred. When combining precast and cast-in-place concrete in composite deck systems required prestress level to prevent tensile stresses is likely to be governed by differential creep and shrinkage strains, which are sensitive to humidity, temperature, curing conditions, and age of precast at integration. All reinforced concrete deck members should meet the crack control requirements for severe exposure.

4-2.6 Other Materials.

FRP, UHMW, and other new materials should be governed by the accepted industry standards for structural design and detailing.

4-3 DECK STRUCTURE DESIGN.

4-3.1 Deck Framing.

Concrete is generally considered the best material for deck framing and should be used for most pier and wharf decks. Although timber, steel, steel/concrete composite, and timber/concrete composite decks have been used in the past, they are neither cost-effective nor suitable for the high concentrated load capacities currently demanded of decks. From durability, maintenance, and life-cycle-cost viewpoints, a concrete deck is superior and is highly recommended. The deck framing should be slabs supported on pile caps, using an all cast-in-place, all precast, or composite construction, as shown in Figure 4-1. For the concentrated loads which typically control the deck design, a solid slab with its high punching shear resistance is recommended. Framing systems using thin slabs, as in cast-in-place slab/beam/girder systems, should not be used because of the tendency to spall along beam/girder corners and edges. Map cracking in the cast-in-place topping at the precast panel joints is sometimes seen. In precast/cast-in-place concrete composite structures design, consider differential creep and shrinkage when specifying post-tensioning stress level. Studies have demonstrated that prestress losses and redistribution of prestress forces can be significant in this construction type, minimizing the effectiveness of the intended crack mitigation measures. For distribution of horizontal loads, pier and wharf decks should be continuous, with as few expansion joints as possible. Where expansion joints are needed, the deck on each side of the joint should be supported on a separate pile cap or girder. Other options are flat plate requiring no pile cap.

Figure 4-1 Concrete Deck Construction

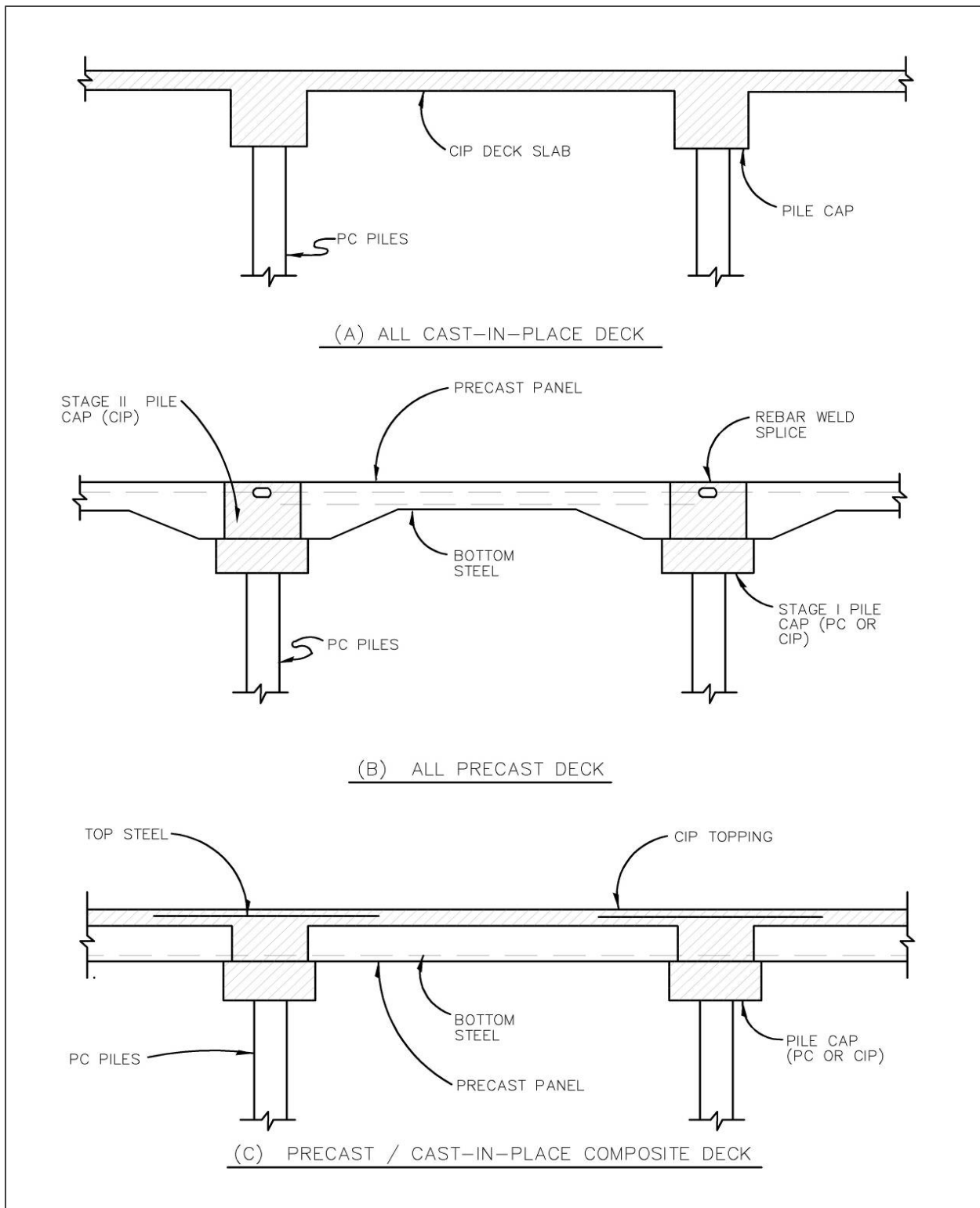

4-3.2 Pile Caps.

Orienting pile caps transverse to the length of the structure provides improved lateral stiffness for berthing and mooring forces. When this orientation is used, longitudinal pile caps are not needed unless crane trackage support or longitudinal seismic resistance is to be provided. For marginal wharves where lateral loads from mooring and berthing loads are transferred to the land, a longitudinal orientation of the pile cap may be considered if feasible for construction. Moments and shears on pile caps from live loads should take into account the elastic shortening of the piles and the effect of soil deformation at and near pile tips.

4-3.2.1 Pile Cap Orientation.

Traditionally, it was assumed to be more cost-effective to orient pile caps (and hence pile bents) transverse to the length of the structure. However, orientation of the pile caps longitudinal to the length of the pile provides uninterrupted paths for utilities that run in this direction, which may result in cost-savings over piers with pile caps in the transverse direction by minimizing conflicts between cap beams and utilities. Use of pile caps oriented in the longitudinal direction will require tie beams designed to transfer lateral loads from mooring and berthing loads to the foundation. Additional stiffness can be added to piers with pile caps in the longitudinal direction with the use of tabletop sections. An example of a cost-effective pier with pile caps oriented in the longitudinal direction and tabletop pile caps can be found in NAVFAC-EXWC-CI-TR-1413, *The Use of Prestressed Concrete for Corrosion Prevention in US Navy Piers*.

For computation of forces from high concentrated loads, the cap behaves as a beam on elastic foundation, and distributes the concentrated load to a number of piles adjacent to the load.

4-3.2.2 Precast/Prestressed Pile Cap.

A durable concept for precast/prestressed pile caps is a single span beam supported on two piles, which is balanced by two cantilevered ends that extend to the mid-span of the adjacent bays as shown in Figure 4-2. Prior to integration with the deck elements, it can be shown with a moment-diagram that the soffit of the cap beam will remain in compression under uniform load. This prestress from gravity will enhance durability by minimizing cracking of the concrete in the splash zone of the pier as illustrated in Figure 4-3. Additional prestress can be specified for the cap beam during fabrication to maintain compression in the concrete under crane loads during installation and for service level loads after integration with the deck elements. Details for this design can be found in NAVFAC-EXWC-CI-TR-1413, *The Use of Prestressed Concrete for Corrosion Prevention in US Navy Piers*. A recommended detail for the joint between adjacent pile cap beams is shown in Figure 4-2.

Figure 4-2 Cantilevered Precast Pile Cap

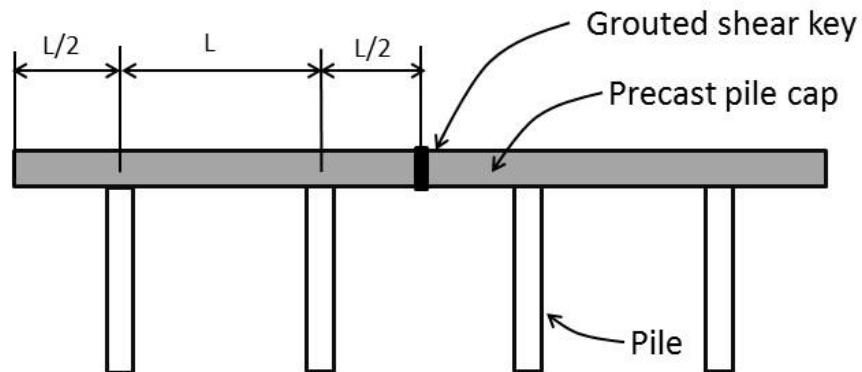

4-3.3 Tabletop Pile Caps.

Precast construction is an effective method to enhance durability of waterfront structures while reducing cost; however, one of the challenges of precast construction is integrating individual pieces into a continuous structure. A solution for precast concrete construction is to use tabletop pile caps, which are two-way elements capable of transferring resisted loads to four support piles. Proper implementation will form a self-contained stable platform that when integrated into the deck diaphragm forms a complete lateral load resisting system. Tabletop configuration may vary based on pier requirements, but three potential tabletop variations are the slab, double cap, and utilidor, which are shown in Figure 4-4 along with a single span pile cap beam. Implementation of tabletop pile caps into a pier design is demonstrated in NAVFAC-EXWC-CI-TR-1413, *The Use of Prestressed Concrete for Corrosion Prevention in US Navy Piers*.

Figure 4-3 Conventional versus Gravity Prestressed Pile Caps

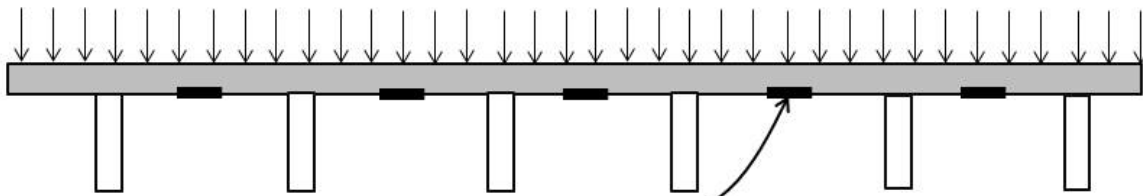

Area of tension cracking and resulting corrosion in pile cap soffit

Conventional CIP Concrete Pile Cap

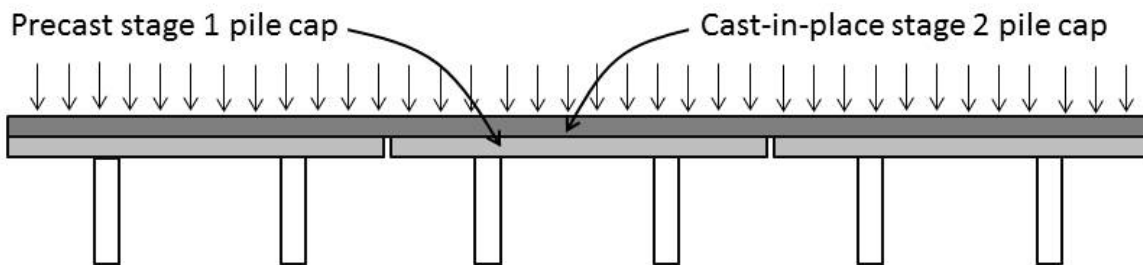

Pile cap and deck panels create compression in bottom of pile cap that is locked in by stage 2 to create crack-free soffit

Gravity-Prestressed Pile Cap



Precast Pile Cap Showing End Configurations

Figure 4-4 Tabletop Pile Cap Variations

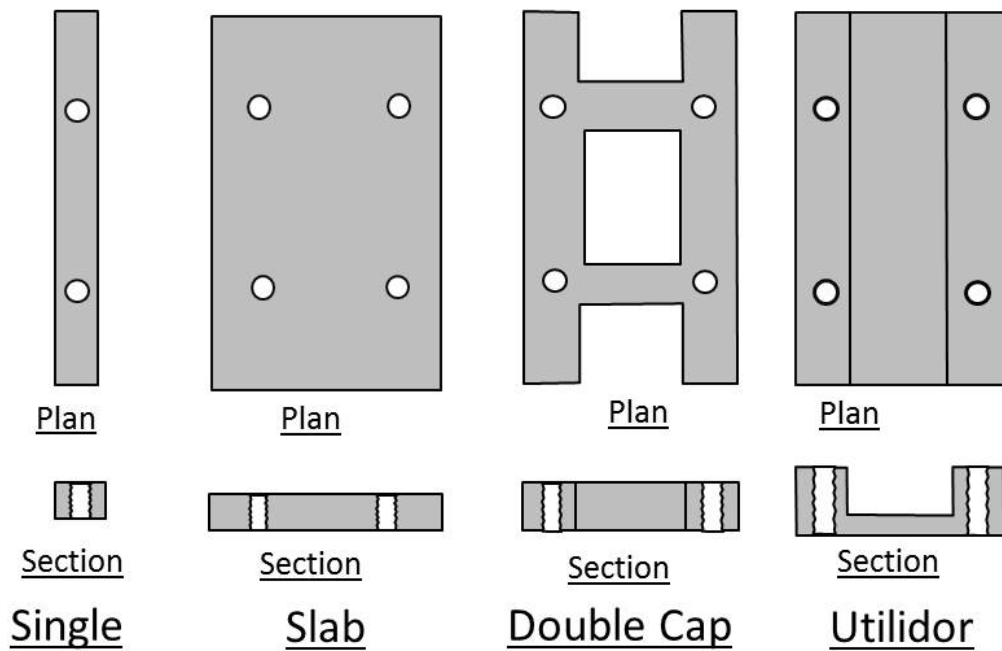
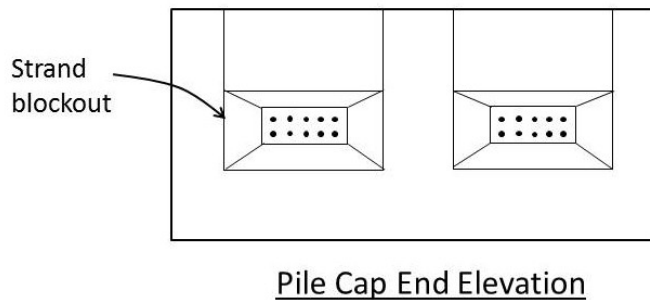
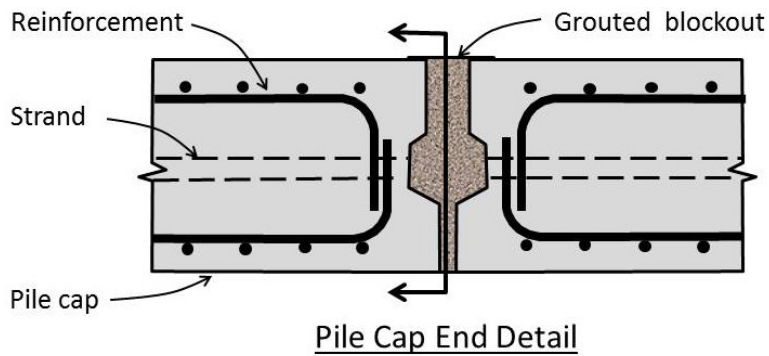

4-4 SUBSTRUCTURE DESIGN.

4-4.1 Geotechnical.

General geotechnical guidance and minimum technical requirements for DoD facilities is contained in UFC 3-220-01, *Geotechnical Engineering*. However, given the somewhat unique aspects of marine geotechnical engineering, traditional geotechnical engineering practices need to be supplemented. In this regard, an appropriate reference is *Handbook of Marine Geotechnical Engineering*. This document addresses a variety of structures ranging from piles, moorings, and anchors and the seafloor response whether in shallow or deep water.

4-4.2 Pile Bent Framing.

A pile-supported framing system is the most popular form for substructure design for open piers and wharves. Several framing concepts for open piers and wharves and marginal wharves are illustrated in Figure 4-5. Many variations and combinations of the illustrated concepts are possible.

Figure 4-5 Substructure Framing Concepts

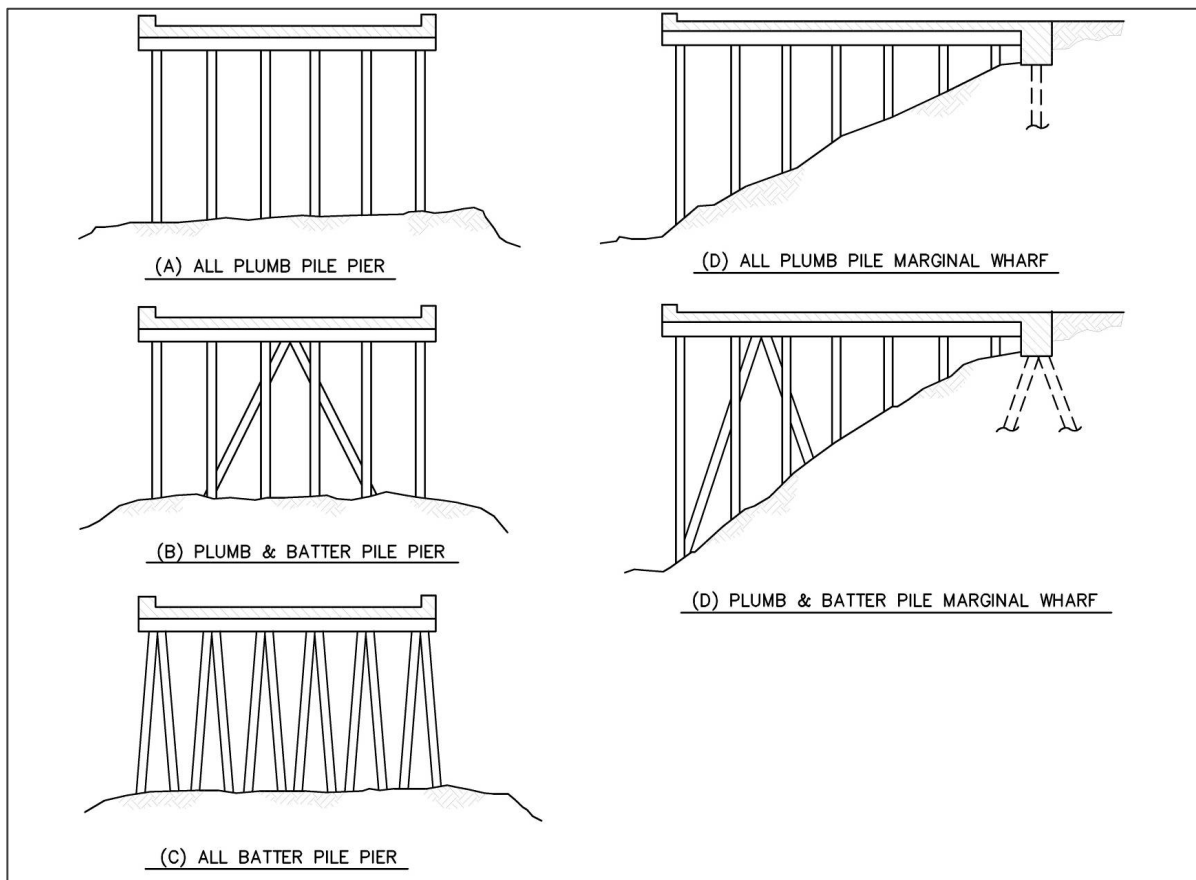

4-4.2.2 All Plumb Pile System.

The lateral loads are resisted by "frame action," whereby the piles and the cap form a moment frame and resist the lateral load primarily by the flexural stiffness of the piles. However, for narrow structures, lateral deflection may be high for even small lateral loads. Also, sidesway is not prevented, which increases the effective length of the pile as a column. If piles vary in unsupported length, the shorter piles will attract a large portion of the lateral load. Because the piles are more efficient for axial loads and less so for bending moments, this framing usually is restricted to shallow waters and light lateral loads. However, for wide structures with a large number of piles, the total stiffness of the system may justify a reduced effective length. A more in-depth stability analysis is needed to validate a reduced effective length. Large diameter steel pipe and precast/prestressed concrete cylinder piles can provide improved lateral stiffness and are attractive for use in areas of high seismic activity.

4-4.2.3 Plumb/Batter Pile Systems.

In this type of framing, all the vertical loads are primarily handled by the plumb piles, and lateral loads are resisted primarily by the batter piles. The behavior of the system is one of "truss action." This system is more cost-effective as the lateral loads are resisted primarily by the axial stiffness of the batter piles. However, very high forces are transmitted to the caps, which will have to be designed and detailed to resist these forces. In areas of high seismic activity, the increased stiffness of the system reduces the period and leads to higher earthquake loads.

4-4.2.4 All Batter Pile System.

This system is a compromise between the two above, and is cost-effective in some circumstances. With this system, the batter slope may be near vertical. Natural periods can be as high as several seconds, making the approach attractive for seismic areas.

4-4.2.5 Batter Pile System with Seismic Isolation.

This system incorporates calibrated isolators or seismic fuses between the wharf deck and batter piles. The system allows for high displacements of the wharf deck once a threshold lateral load causes the isolator slip. Design guidance can be found in ASCE/COPRI 61-14, *Seismic Design of Piers and Wharves* and ASCE 7-10, *Minimum Design Loads for Buildings and Other Structures*. Consider the magnitude of lateral berthing and mooring forces such that they do not exceed the threshold lateral force of the isolator. In this case a separate fendering structure may be required.

4-5 MOORING HARDWARE.

4-5.1 General.

Ships are usually moored to bollards, bitts, and cleats. Occasionally, ships may be tied to a quick-release hook. The position of a ship on a berth is usually controlled by utility hookup and brow location requirements. The crew in charge of tying up the ship will

usually tie the lines to whatever mooring hardware is convenient to give the required horizontal angle. This often results in lines tied to a lower capacity cleat while a high-capacity bollard may only be a few feet away. Hence, consider using only one type of high-capacity mooring hardware throughout the facility. When possible, size this mooring hardware for the maximum size vessel that could possibly use the facility. Space hardware to maximize the berth flexibility for use by ships other than the specific vessel the berth was designed to accommodate. In addition, mooring hardware requirements will depend on the mooring service type assigned to the berth as defined in UFC 4-159-03, *Design: Moorings*. For mooring service types III and IV, consider providing additional heavy weather mooring hardware set away from the face of the pier or wharf. Balance the desire to provide the higher capacity hardware with the additional cost of the higher strength hardware and supporting structure. The geometry of the hardware should preclude mooring lines from slipping off, as the mooring angle is often very steep.

4-5.2 Hardware Types.

Additional information (such as tabular data and figures) on mooring hardware is contained in UFC 4-159-03, *Design: Moorings*; UFC 4-150-08, *Inspection of Mooring Hardware*; and TR-6014-OCN, *Mooring Design Physical and Empirical Data*. The following are the most commonly used types of mooring hardware:

4-5.2.1 Bollards.

A bollard is a short single-column cast-steel fitting that extends up from a baseplate that is secured to a strong point of a shore structure or berthing facility. Bollards are used in checking the motion of a ship being moored, by tightening and loosening mooring lines that are fastened to them. Bollards are also used for securing a ship that has been placed in its final moored position. Do not use bollards without ears in facilities where a high vertical angle of the mooring line is anticipated, to prevent lines from slipping off.

4-5.2.2 Bitts.

Bitts are short, double-column, cast-steel fittings fastened to the deck of berthing facilities. Bitts are also found on navy vessels. They are used to secure a vessel. The double-columns allow for convenient and rapid tying and releasing of mooring lines, as well as for guiding a line through to other hardware.

4-5.2.3 Cleats.

Currently, available cleats are low-capacity, cast steel deck fittings having two projecting arms that are intended to be used for securing mooring lines of small craft. They are provided at most naval facilities. Given a choice, line-handling crews will use cleats in preference to bollards or bitts, even for large ships, as the possibility of line slippage is remote. However, cleats can easily be overloaded when they are used in lieu of major fittings such as bollards. Because of the low holding capacity of cleats, they should not be used in combination with higher capacity deck fittings.

4-5.2.4 Chocks.

Chocks are either stationary or roller-equipped cast deck fittings on ships that are used to train the direction of a mooring line. Chocks are available either open at the top, permanently closed, or closed by a hinged closing piece.

4-5.2.5 Capstans.

Ships outfitted with winch-mounted wire rope mooring lines require greater pulling power than can be provided by one or two deck hands to draw out the ship's lines. The assignment is handled by capstans mounted along the face of the wharf. The capstans are small electric winches with a drum rotating about a vertical axis. The capstan is used by a deck hand that receives a messenger line at the end of which is fastened the sling of the wire rope hawser. The capstan, receiving several wraps of the messenger line, provides the pulling power needed to draw out the wire rope hawser. The messenger line is then returned to the ship. Capstans are also used as primary guidance (breasting and in-haul) to berth ships in dry docks and slip-type berths (Trident facilities). For these uses, the capstans are of larger capacity and are typically two-speed.

4-5.2.6 Quick-Release Hooks.

The quick-release hook, generally mounted on a swivel base, is a deck fitting used to receive mooring lines. When a ship is required to make a hasty departure from its berth, a tug on the hook's release mechanism unfastens the mooring line. The mechanism can also be tripped from the ship when a tag line is provided. Thus, a ship can make a sudden departure without the assistance of shore personnel. Quick-release mooring hooks with integral power capstans are necessary for securing the steel mooring lines on petroleum tankers at fuel piers, while bollards are needed for the supplementary lines other than steel.

4-5.3 Strength.

The required strength of mooring hardware and its fastenings is determined through mooring analysis. Mooring hardware can and does receive more than one line and as many as three are not unusual. Design anchorage of mooring hardware based on the rated capacity e.g. for the anchorage of a Special Mooring Bollard "A" the working (service level) capacity is either a 660 kip (2,936 kN) horizontal line pull, or a 430 kip (1,913 kN) line pull at an angle of 45 degrees from the horizontal. Line loads are applied just below the horn elevation, and typically from 0 to 180 degrees in plan away from the pier or wharf. For strength level design use the mooring load factor listed in Table 3-7. Capacity design is used for anchorage and local foundation structural design only. Global structural design shall be based on mooring analysis. The sizes of mooring lines are limited to those that can be conveniently handled by deck hands. Thus, wire rope lines generally do not exceed 1-3/4 inch (45 mm) diameter.

4-5.4 Placement.

If a berthing facility were always to receive the same class of ship, each of which had identical arrangements for putting out mooring lines, a specific pattern for mooring hardware spacing, based on the ship's fittings, would be satisfactory. However, most naval berthing facilities require a high degree of flexibility in order to be able to receive several types and sizes of ships. Therefore, a universal pattern for mooring hardware spacing is preferred. Mooring hardware spaced at 60 feet (18.3 m) on centers along the berthing face of a structure will, in most instances, provide the number of fittings required to secure the ships during the periods of time that wind velocities and conditions of sea do not exceed the design criteria established for Mooring Service Types I and II. Mooring Service Types III and IV will likely require additional high capacity storm bollards which are normally set back as far as is practical from the face of the berth to provide a shallow line angle.

- a. A berthing facility that will accommodate ships having large wind areas, such as aircraft carriers, should be outfitted with 12 to 100 ton (107 to 890 kN) bollards at 100-foot (30.5 m) centers and 4 to 200 ton (36 to 1779 kN) storm bollards at each end. Locate the storm bollards, which would be used to secure breasting lines, inshore from the face of the wharf, thus reducing vertical angles and permitting the use of longer (safer) mooring lines.
- b. At submarine berths where mooring lines go down to the submarine, locate the mooring hardware as close as possible to the waterside edge of the bullrail to minimize chafing of the lines. Where this is not feasible, cast a continuous smooth member, such as a bent plate, in the concrete bullrail.

4-6 MOORING DOLPHINS/PLATFORMS.

4-6.1 Design.

The primary load for a mooring dolphin comes from the tension in the mooring line. It is typically constructed as an open pile supported structure. Where filled (solid) construction is permitted, a single sheet pile cell may be used. When a platform is provided for the dolphin, it should be large enough to allow a 3-foot-wide (1 m) walking space all around the mooring hardware.

4-6.2 Construction.

Timber mooring dolphins can be constructed from 7, 19, or 37 wood piles with a king pile in the center and other piles arranged in a circular pattern around the king pile. A 19-pile dolphin is illustrated in Figure 4-6 (A). Limit the use of timber dolphins to facilities not requiring high capacity mooring points. Timber dolphins may be required for magnetic sensitive facilities. In areas with ready access to timber piles, timber dolphins may be popular for small craft, tugs, patrol craft and barges. For higher loads, a concrete dolphin is preferred, which is illustrated in Figure 4-6 (B). Because both timber and concrete dolphins can be expected to move significantly (1 to 6 inch (25 to

152 mm)) from the lateral load, design and detail the access walkway to allow for this movement.

Figure 4-6 Mooring Dolphins

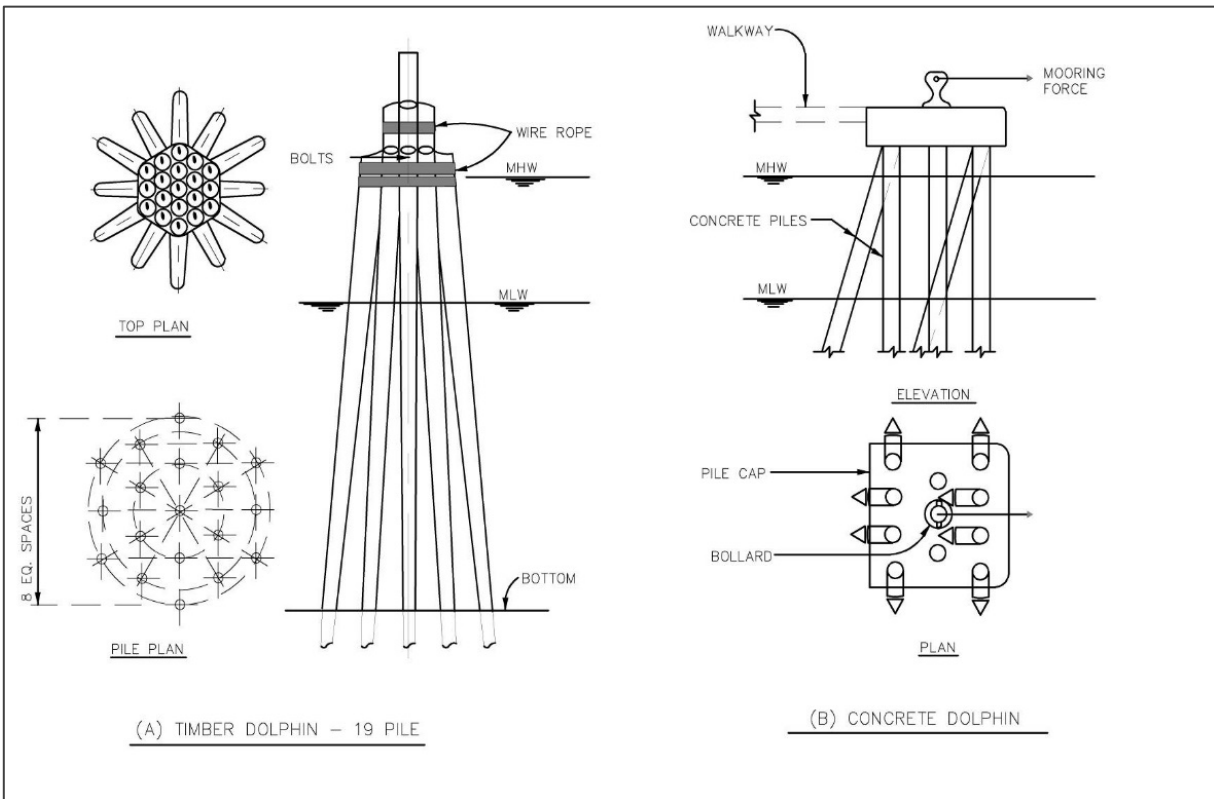

4-7 MISCELLANEOUS CONSIDERATIONS.

4-7.1 Expansion Joints.

Because expansion joints require frequent maintenance for proper functioning, piers and wharves should use as few joints as possible. The size and number will depend on the temperature range and structural system employed. Provide expansion joints at the junction of an approach with the main structure and such other places where there is a major structural discontinuity. Provide additional expansion joints where necessary to limit buildup of thermal loads. (See also previous section: Thermal Loads) Continue the joint through railroad tracks and crane rail tracks. Recommended details are shown in Figures 4-7 and 4-8. Likewise, detail utilities crossing expansion joints to accommodate the expected longitudinal and lateral movements.

4-7.2 Drainage.

Pier and wharf decks should be sloped in transverse and longitudinal direction to deck drains or scuppers to provide for drainage of storm water. Where permitted, the storm water can be drained off to the water below; however, if fuel, oils, and chemicals are to

be handled on the facility, the storm water should be collected and piped off for treatment. A complete review of local jurisdictional requirements for storm water management and treatment required for each facility may vary significantly between locations. It is customary to use subsurface drains in ballasted decks to handle any small amounts of water that may seep through the paving. This water is normally not collected.

4-7.3 Bullrail.

On all waterside edges of piers and wharves, provide a curb or bullrail 10 to 12 inch (254 to 305 mm) high by 12 to 24 inch (305 to 610 mm) wide. Some mooring hardware may be accommodated within the 24-inch (610 mm) width, thus permitting a clear inside face for easy snow removal and line handling. As shown in Figure 4-9, it is also generally possible to house utility vaults within the width of the bullrail. The bullrail should be sufficiently reinforced and anchored to the deck structure. When a continuous bullrail is available, it may be reinforced to serve as chord member for a structural diaphragm.

4-7.4 Utility Trench.

Because the utility services are mostly needed along the pier or wharf edge, the main utility trenches on single deck piers should be kept close to the bullrail. The trench may be underhung or kept above, as shown in Figure 4-10. The trench covers should be removable and made of concrete, steel, or composite construction. Fiberglass reinforced plastic (FRP) trench covers have been used on piers and offer the advantages of light weight and durability in a corrosive marine environment. When using FRP trench covers, give consideration to the proximity of heated steam lines.

Although the trench covers need not be watertight, use a good seal at joints to prevent accidental seepage of spilled liquids. Frequently spaced drains should be placed along the trench to prevent flooding. Provide adequate width and depth to allow access for maintenance of utilities.

Figure 4-7 Railroad Track Support

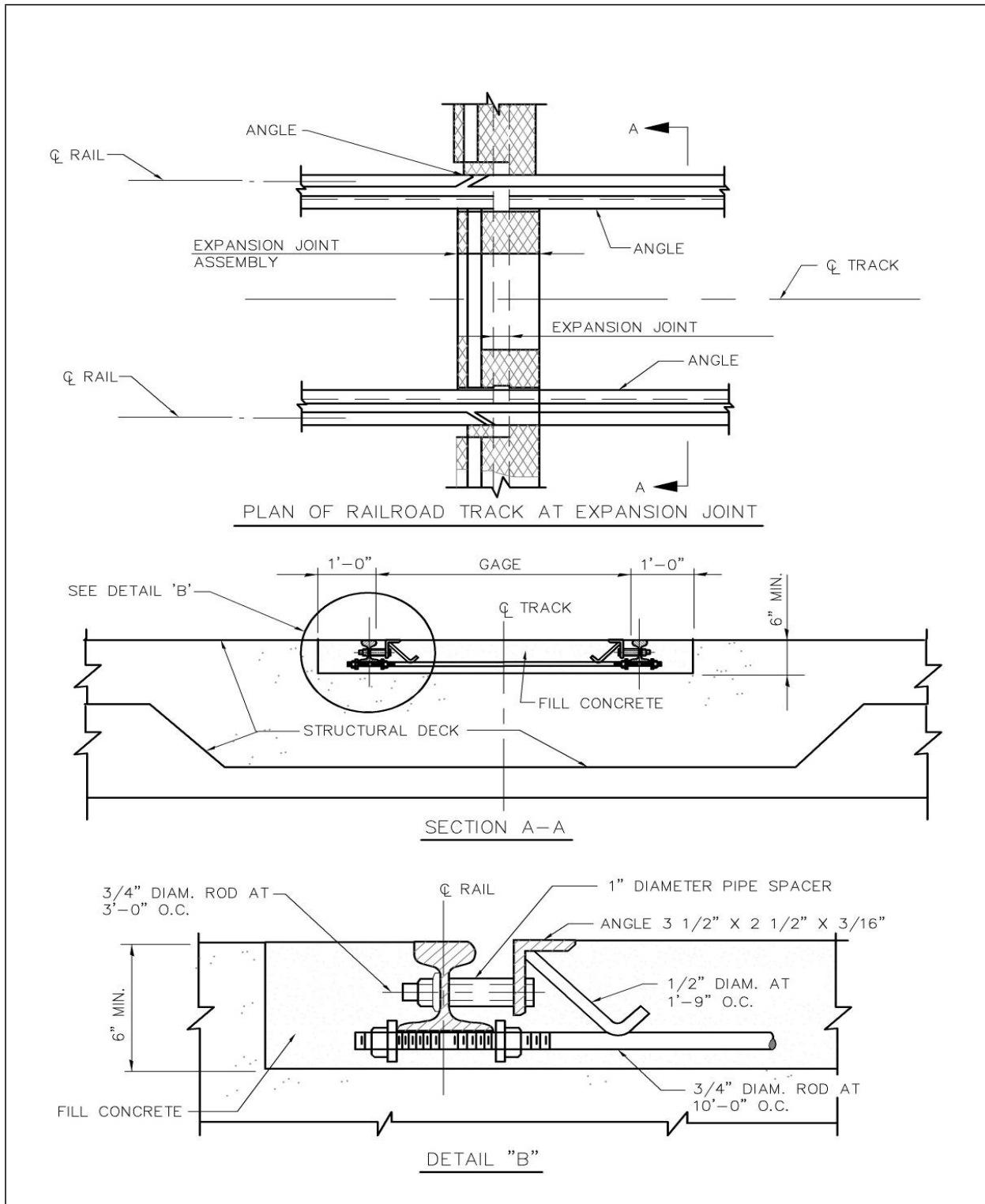

Figure 4-8 Crane Rail Support

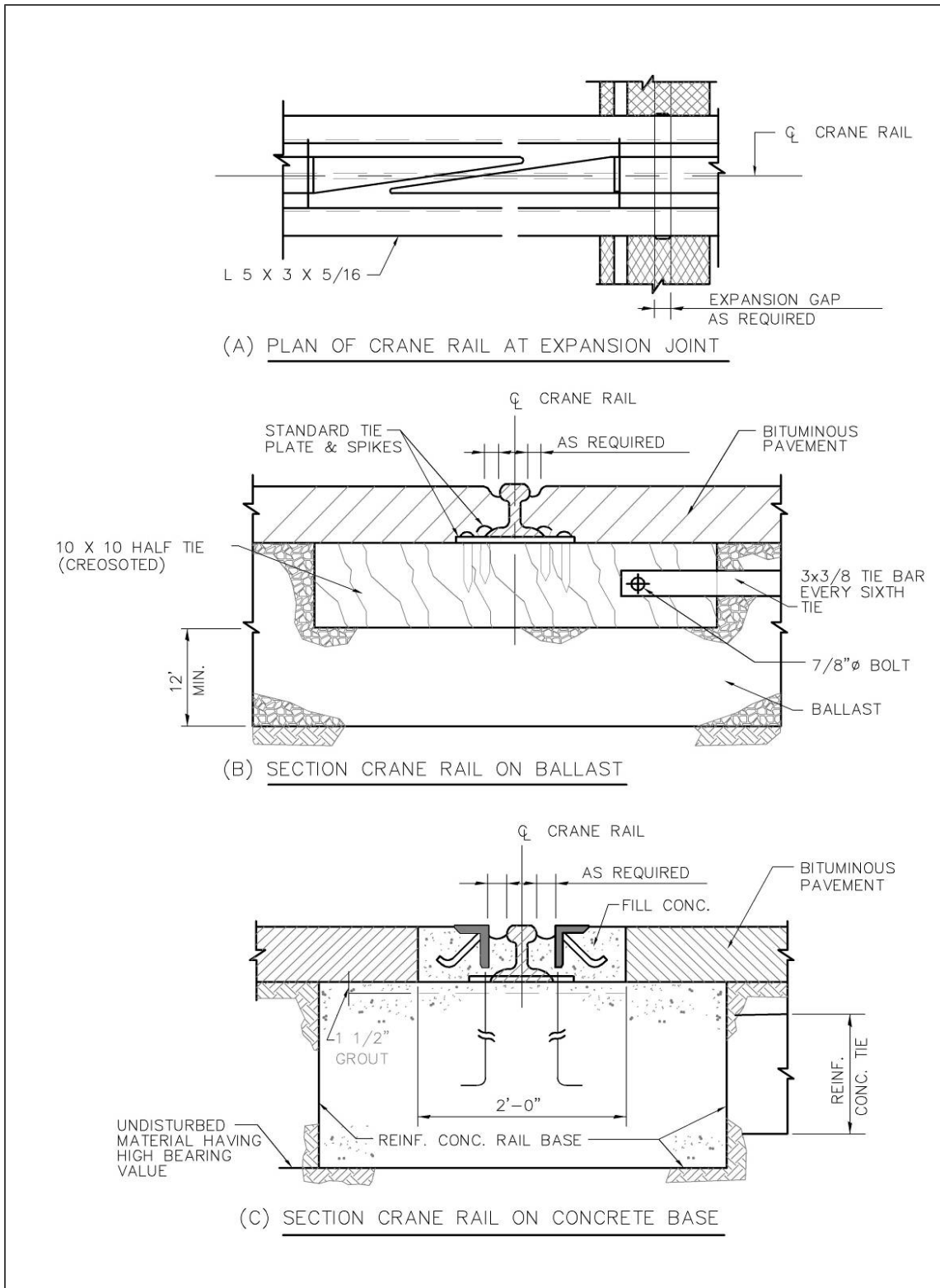

Figure 4-9 Bullrail Details

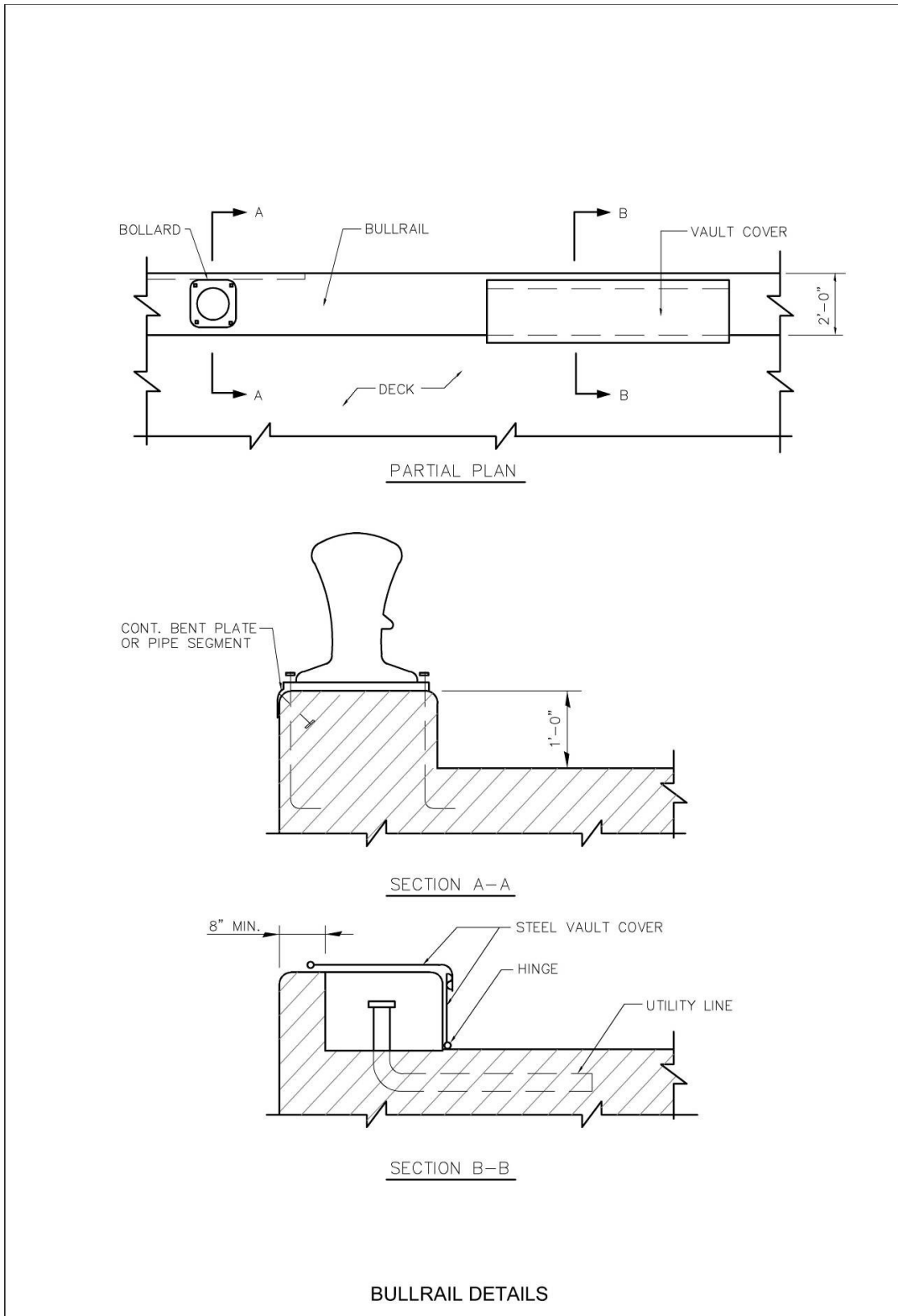
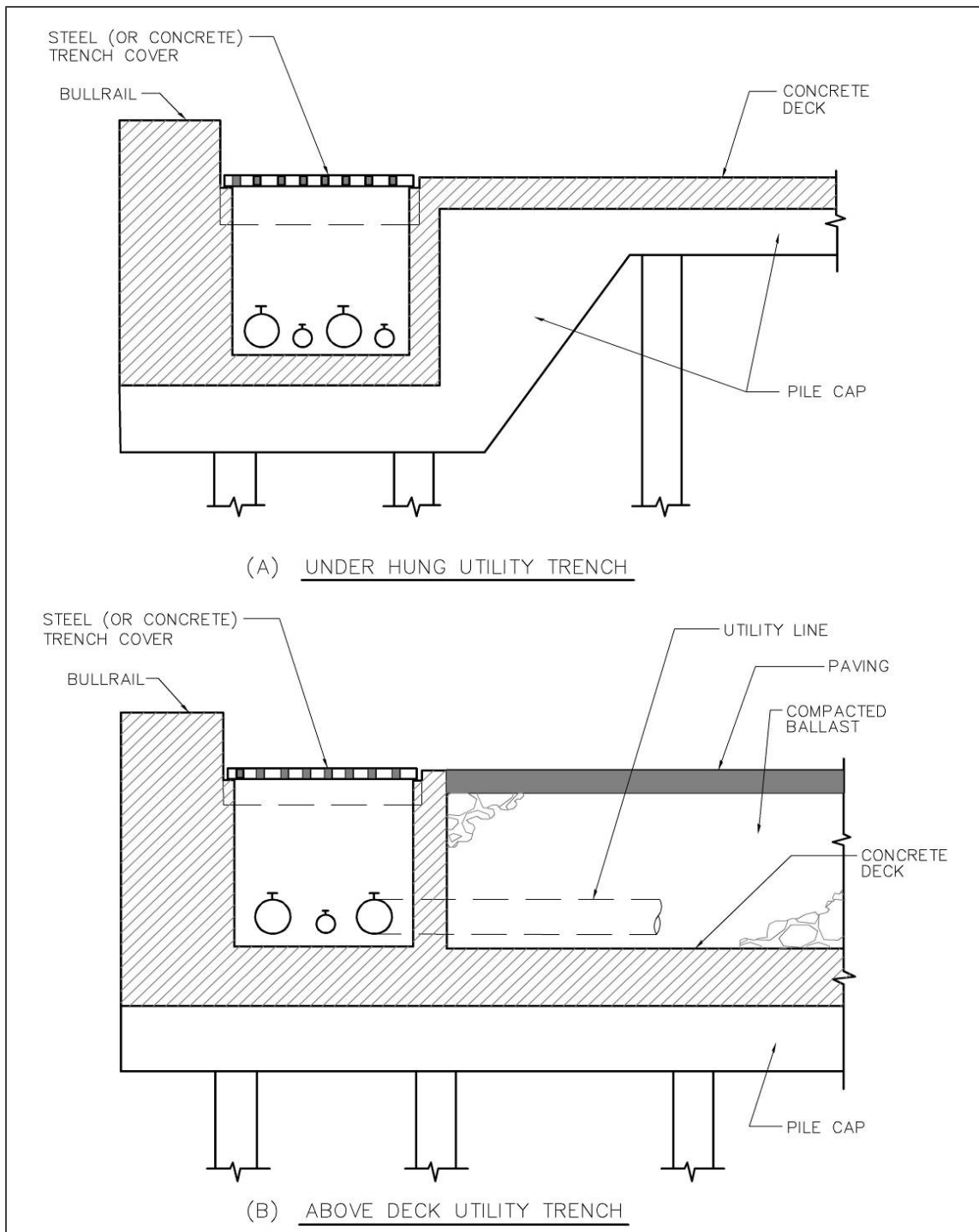

Figure 4-10 Utility Trench Concept



4-7.5 Utility Hoods.

Protect connection points or "utility risers" projecting above deck or bullrail from snagging of mooring lines by pipe rails or concrete hoods, as shown in Figure 4-11. Alternatively, when the bullrail is wide enough, employ hinged utility covers like the one shown in Figure 4-9. For convenience of the users, the risers should not face away from the ship, and should be adequately sized for ease of operation.

4-7.6 Wearing Course.

Generally, a wearing course is not needed for concrete deck structure. However, for precast concrete decks, an asphalt concrete or cement concrete wearing surface may be utilized to provide a slope for drainage. For ballasted decks and for solid (filled) type construction, a wearing course is necessary. For these applications, asphaltic concrete is preferred over cement concrete as the former is easier to repair and maintain and better tolerates substrate movement.

Figure 4-11 Utility Hood

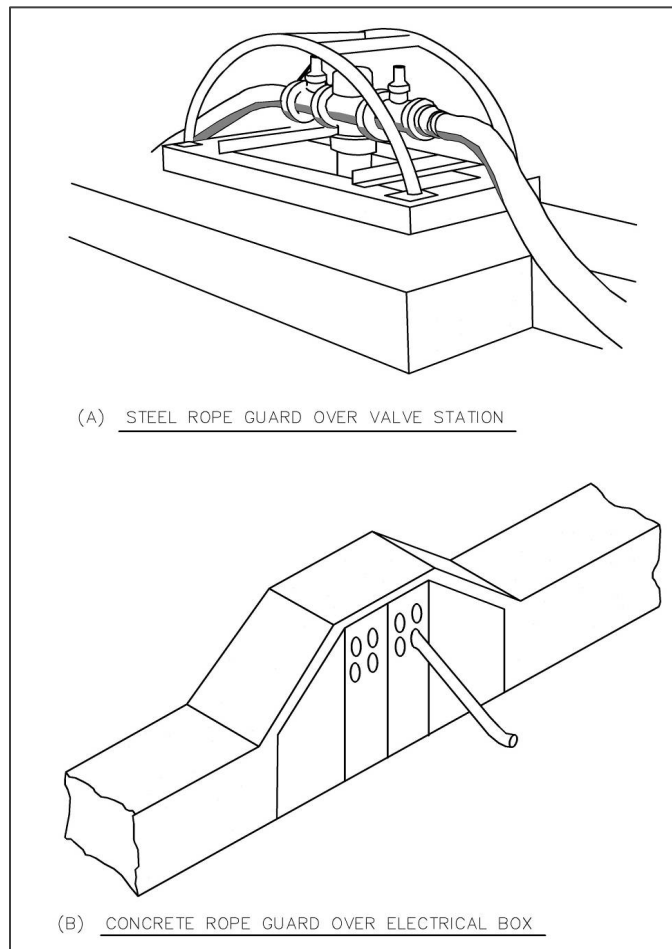

This Page Intentionally Left Blank

CHAPTER 5 FENDER SYSTEMS

5-1 GENERAL CONSIDERATIONS.

5-1.1 Description.

The fender system is the interface between the ship and the shore facility. During the berthing of a ship, the fender system is meant to act as a buffer in absorbing or dissipating the impact energy of the ship without causing permanent damage to the ship or the shore facility. Where ships are to be berthed against relatively inflexible solid piers and wharves, protection of the ship is a critical function. When ships are to be berthed against pile-supported piers, wharves, and dolphins (which are relatively flexible), protection of the structure may be the more serious concern. Once the ship is successfully berthed and moored to the shore facility, the fender system continues to provide the interface between ship and shore and transmits the environmental loads (wind, waves, and current) on the ship to the structure. For submarine and other low-profile ship berthing, the fender system also provides a physical barrier to prevent the vessel from going underneath the pier.

5-1.2 Berthing Practice.

The selection and design of a fender system is highly dependent on the berthing practice employed at the particular facility. Typically, two or more tugboats assist large ships into the berth. In some locations, smaller ships may be allowed to come in on their own power. When assisted by tugs, the ship would arrive off the berth and parallel to it. The ship then stops dead in the water and the tugs push and pull the ship transversely toward the berth in an attempt to make contact with as much of the fender system as possible. When unassisted by tugs, the smaller ship will be eased into its berth at some slight angle, referred to as the angle of approach. In both cases, the initial contact is limited to a relatively small portion of the fender system. Assumptions will have to be made regarding the approach angle and contact length.

5-1.3 Camels and Separators.

Camels are located between ships and piers or wharves. Separators are located between nested ships. This practice is the most significant difference between commercial ship berthing and naval ship berthing. Berthing against camels concentrates the impact energy to a small length of the fender system as well as applies the energy at some distance below the deck. This is a critical aspect in all fender system design for Navy ships. A fender system designed for commercial ships will, in general, not be satisfactory for Naval applications. The practice of using camels has resulted in a general trend for a minimum of hull protrusions near the waterline. Fender systems with higher fender contact area are more susceptible to damage from longitudinal movement of the vessel due to snags.

5-1.4 Systems Approach.

The impact energy of the berthing ship is absorbed in a complex system of interconnected elements. For the system shown in Figure 5-1, the load passes from the ship's hull to the camel, which is backed by a series of fender piles. The fender piles, in turn, are supported by rubber fender units at the deck level. In this case, the ship's energy is absorbed by the ship's hull, rubbing strips, camel, fender piles, and rubber fenders at deck level. The system can be modeled as shown in Figure 5-1. The energy absorbed and the force developed, by each element can only be solved by an iterative process.

Figure 5-1 Energy Model of a Fender System

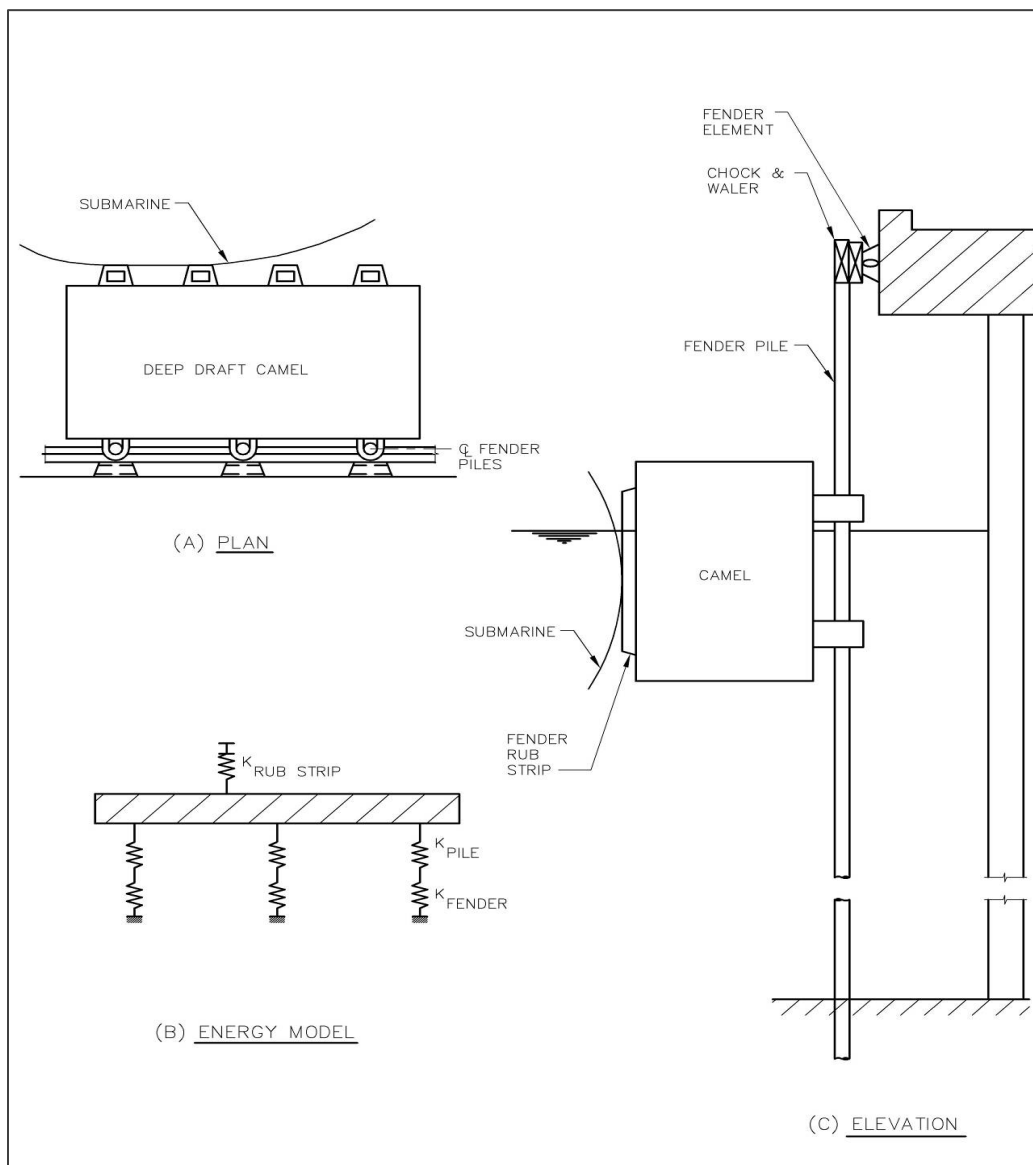

5-1.5 Functional Requirements.

5-1.5.1 Energy Absorption.

Design all fender systems for absorption of the ship's berthing energy in all the structural types of piers and wharves.

5-1.5.2 Normal Berthing.

The fender system should be able to absorb the energy from normal berthing operations within the working stress or acceptable deformation range as defined in this section. Most manufacturers indicate a load deflection curve tolerance of plus or minus 10%. If this is determined to be the case, the design normal berthing reaction on the structure should be increased by 10% and the normal energy absorption for design should be decreased by 10%. Variations in the speed of testing of fenders may affect the resulting load-deflection curves. Where the test loads are applied rapidly, i.e., at a speed comparable to the actual ship berthing, the load-deflection will indicate higher reaction and energy than if the test load is applied slowly. Therefore, take care when comparing test results from different manufacturers, and make appropriate adjustments in the factors of safety used in design. Differences on the order of 30% can be expected.

5-1.5.3 Accidental Berthing.

Because the fender system is less expensive than the ship or the berthing structure, some damage to it may be permissible and acceptable. So, in the event of an accidental situation, it is the fender system that should be "sacrificed." Loss of the berth has a much more serious consequence than loss of part or all of the fender system in terms of the cost and time required to restore the facility. The cost and time to repair a damaged ship is of much greater concern than the berth and the fender system. The accidental condition may be caused by increased approach angle or approach velocity or a unique situation that cannot be anticipated. In the absence of any other accident scenario, increase the berthing energy as calculated in this chapter by at least 50% and the fender system should be capable of providing this "reserve" capacity at or near failure of the system materials (including soils).

5-1.5.4 Moored Condition.

All fender systems selected should be capable of safely transferring the environmental loads on the ship to the mooring structure.

5-1.5.5 Hull Damage.

Design all fender systems to prevent permanent deformation of the ship's hull. It is much more expensive to repair a ship's hull than rehabilitate a damaged fender system. The composition of a typical Navy hull is steel plating welded to longitudinal (horizontal) stiffeners. Generally, the stiffeners are of sufficient strength to preclude failure from fender loading. However, the hull plating may yield when subjected to a uniformly distributed overload on the panel. Fender systems with rigid face elements or in

combination with rigid camels tend to concentrate the reaction forces on the ships frames versus the hull plating due to the relative stiffness of the frames.

5-2 BERTHING ENERGY DETERMINATION.

5-2.1 Methods.

The following methods can be used in the determination of berthing energy of the ship.

5-2.1.1 Kinetic Method.

The kinetic energy method has been the widely accepted method for piers and wharves of Naval facilities. When the displacement tonnage of the ship is known, the energy equation can be written as:

$$E_{ship} = 1/2 W * v^2 / g \quad \text{(Equation 5-1)}$$

where:

- E_{ship} = Berthing energy of ship (foot-lbs)
- W = Weight of the ship in pounds (displacement tonnage, long tons x 2,240)
- g = Acceleration due to gravity (32.2 feet/second²)
- v = Berthing velocity normal to the berth (feet/second)

However, there are several factors that modify the actual energy to be absorbed by the fender system. The expression can be written as:

$$E_{fender} = C_b * C_m * E_{ship} \quad \text{(Equation 5-2)}$$

where:

- E_{fender} = Energy to be absorbed by the fender system
- C_b = Berthing coefficient = $C_e * C_g * C_d * C_c$. Sometimes eccentricity (C_e), geometric (C_g), deformation (C_d), and configuration (C_c) coefficients are combined into a single value called berthing coefficient.
- C_m = Effective mass or virtual mass coefficient

Each of these coefficients is discussed separately below.

- a. Eccentricity Coefficient (C_e). During the berthing maneuver, when the ship is not exactly parallel to the berthing line, not all the kinetic energy of the ship will be transmitted to the fenders. Due to the reaction from the fender, the ship will start to rotate around the contact point, thus dissipating part of its energy. Treating the ship as a rigid rod of negligible width in the analysis of the energy of impact on the fenders leads to the simple formula:

$$C_e = k^2 / (a^2 + k^2)$$

where:

- k = Radius of longitudinal gyration of the ship, feet.
- k = $(0.19C_{BL} + 0.11) * L$ (*Guidelines for the Design of Fender Systems*, PIANC, 2002)
- a = Distance between the ship's center of gravity and the point of contact on the ship's side, projected onto the ship's longitudinal axis, feet.
- C_{BL} = Block coefficient

$$C_{BL} = M / (L * B * D * \rho)$$

where:

- M = Displacement of vessel, long tons
- L = vessel length, feet
- B = Beam of vessel, feet
- D = Draft of vessel, feet
- ρ = Density of water (64 lb/ft³)

Values of C_e typically are between 0.4 and 0.7. The values for C_e may be selected from Figure 5-2.

- b. Geometric Coefficient (C_g). The geometric coefficient, C_g , depends upon the geometric configuration of the ship at the point of impact. It varies from 0.85 for an increasing convex curvature to 1.25 for concave curvature. Generally, 0.95 is intended for the impact point at or beyond the quarter points of the ship, and 1.0 for broadside berthing in which contact is made along the straight side.
- c. Deformation Coefficient (C_d). This accounts for the energy reduction effects due to local deformation of the ship's hull and deflection of the whole ship along its longitudinal axis. The energy absorbed by the ship depends on the relative stiffness of the ship and the obstruction. The deformation coefficient varies from 0.9 for a non-resilient fender to nearly 1.0 for a flexible fender. For larger ships on energy-absorbing fender systems, little or no deformation of the ship takes place; therefore, a coefficient of 1.0 is recommended.
- d. Configuration Coefficient (C_c). This factor has been introduced to take into account the difference between an open pier or wharf and a solid pier or wharf. In the first case, the movements of the water surrounding the berthing ship are not (or hardly) affected by the berth. In the second case, the water between the berthing ship and the structure is squeezed, which introduces a cushion effect that represents an extra force on the ship away from the berth and reduces the energy to be absorbed by the fender system. Therefore, a reduction factor has to take care of this effect. Experience has indicated that for a solid quaywall about one quarter of the energy of the berthing ship is

absorbed by the water cushion; therefore, the following values for C_c appear to be justified:

- For open berth and corners of solid piers, $C_c = 1.0$.
- For solid piers with parallel approach, $C_c = 0.8$.
- For berths with different conditions, C_c might be chosen somewhere between these values.

Figure 5-2 Eccentricity Coefficient, C_e

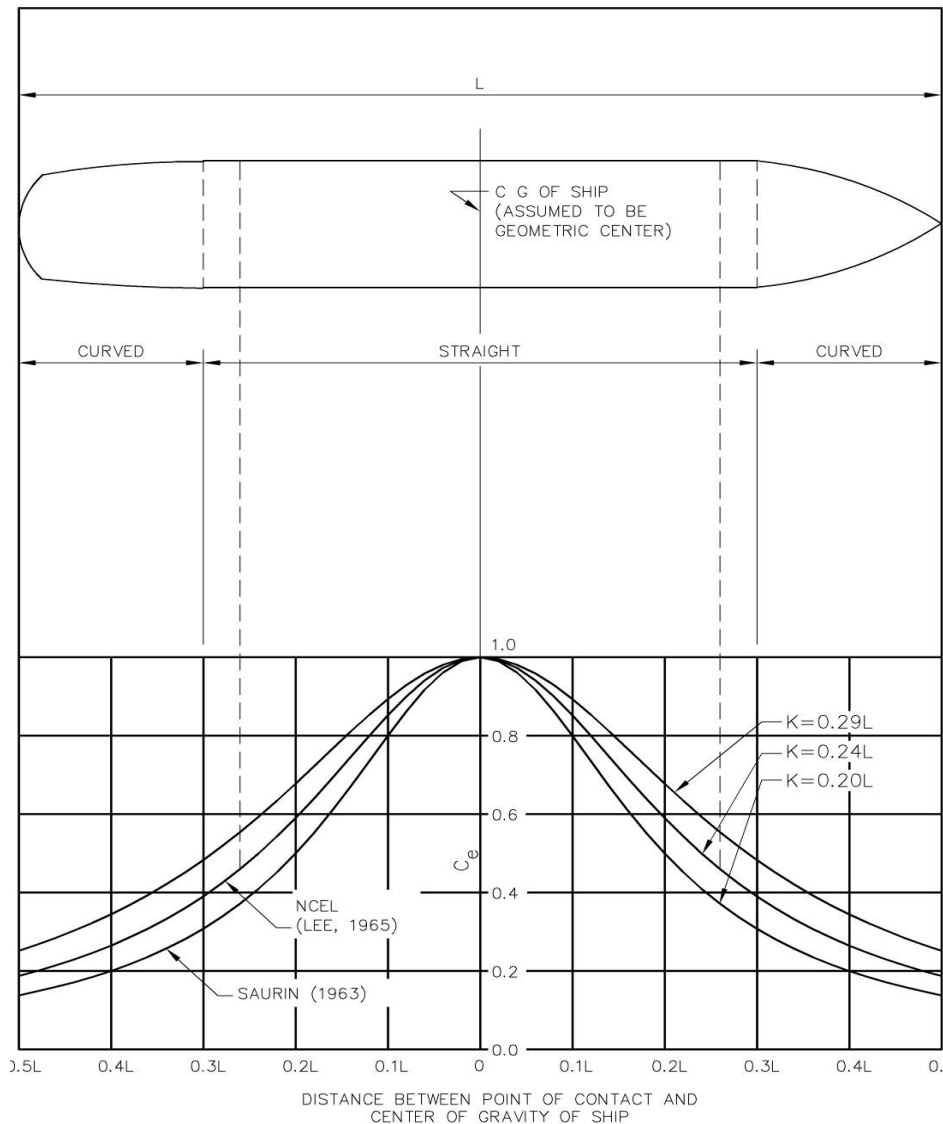

- e. Effective Mass or Virtual Mass Coefficient (C_m). When a ship approaches a dock, the berthing impact is induced not only by the mass of the moving ship, but also by the water mass moving along with the ship. The latter is generally called the "hydrodynamic" or "added" mass. In determining the kinetic energy

of a berthing ship, the effective or virtual mass (a sum of ship mass and hydrodynamic mass) should be used. The hydrodynamic mass does not necessarily vary with the mass of the ship, but is closely related to the projected area of the ship at right angles to the direction of motion. Other factors, such as the form of ship, water depth, berthing velocity, and acceleration and deceleration of the ship, will have some effect on the hydrodynamic mass. Procedures for determining added mass are contained in TR-6064-OCN, *Berthing Guidelines for Submarines* and TR-6074-OCN, *Added Mass for Berthing U.S. Navy Vessels*.

The equations for added mass are as follows:

For submarines:

$$C_m = 2.36 + 1.74 * (T/d)^{3.5}$$

where:

T = vessel draft at mid-ships, feet
 d = water depth at berth, feet

For all other surface vessels:

$$C_m = C_{M0} + (C_{m1} - C_{M0}) * (T/d)^{3.5}$$

where:

C_{M0} = added mass coefficient for $T/d = 0$ deepwater limit
 C_{m1} = added mass coefficient for $T/d = 1$ shallow water limit
 T = vessel draft, feet
 d = water depth, feet
 $C_{M0} = 1.3 + 1.5 * (T/B)$
 B = vessel beam, feet
 $C_{m1} = F * [12.4(T/B)^{0.3} - 50 (T/L)]$
 $F = 1.5 * C_b$ for $C_b < 0.6$
 $F = 0.9$ for $C_b > 0.6$

(C_b = berthing coefficient as defined previously)

- f. Berthing or Approach Velocity (v). It should be noted that the kinetic energy of the berthing ship is a function of the square of the normal component of its approach velocity. Thus, the kinetic energy, as well as the resultant force on the berthing structure, is sensitive to changes in approach velocity. By doubling the design value of the approach velocity, the ship's kinetic energy is quadrupled. Design values used for the approach velocity normal to the berth may vary from 0.25 to 1.50 ft/s (0.08 to 0.46 m/s), depending on the size of

the ship being docked and the tug assistance that is employed. Larger vessels with adequate tugboat assistance can generally berth gently and the lower design velocity may be used. Smaller vessels that self-dock may approach the wharf at considerably higher speeds and, accordingly, the higher design velocity should be used. The berthing velocity is also affected by the difficulty of the approach, maneuvering space for tugs (slip width), and location of the pier or wharf facility. Anticipate higher approach velocities when the berth is located in exposed waters where environmental loads cause difficulty in controlling the ship. Also, currents in tidal estuaries in protected waters can be of major concern. Approach velocity normal to the berth may be taken from Figures 5-3 and 5-4. Determining whether a facility is "exposed," "moderate," or "sheltered" depends on the environmental conditions at the site and is a matter for professional judgment by the designer. Most naval facilities in the United States are situated in protected waters and can be taken as "sheltered." Where high currents (0.3 ft/s (0.09 m/s) or more) or strong winds (40 knots (20.6 m/s) or more) occur frequently, a "moderate" condition should be assumed. The "exposed" condition may be used when unusually severe currents and winds are present. However, local experience with ship berthing should control the selection.

Figure 5-3 Berthing Velocity for Small Ships (up to 20,000 tons)

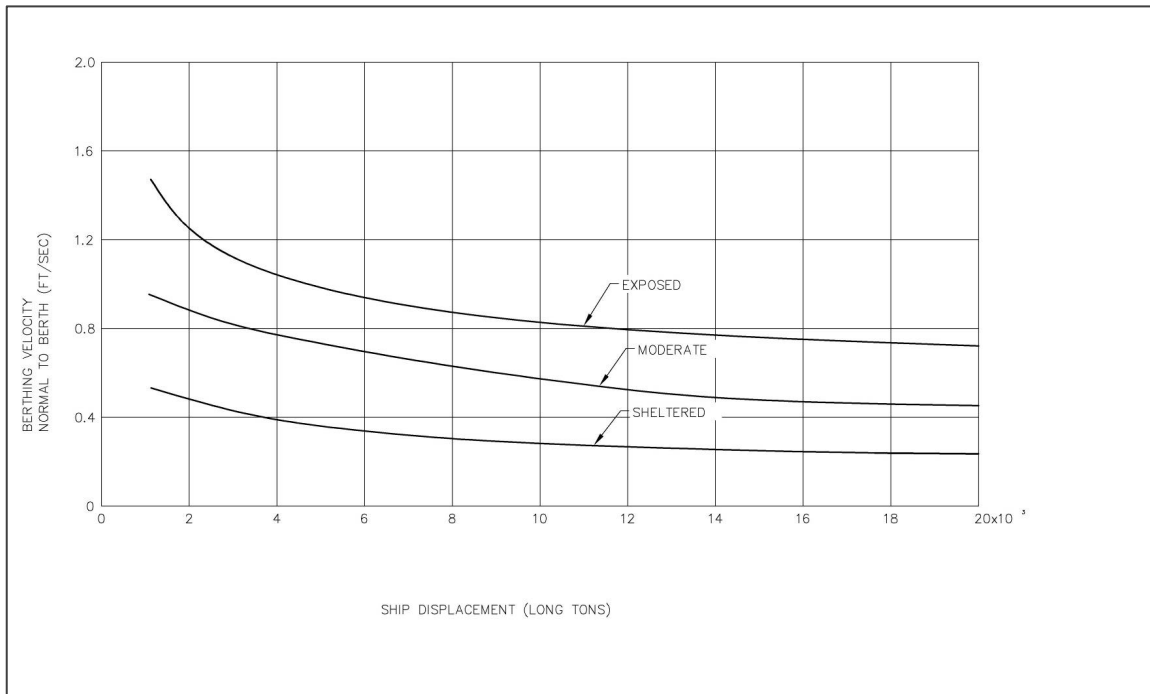
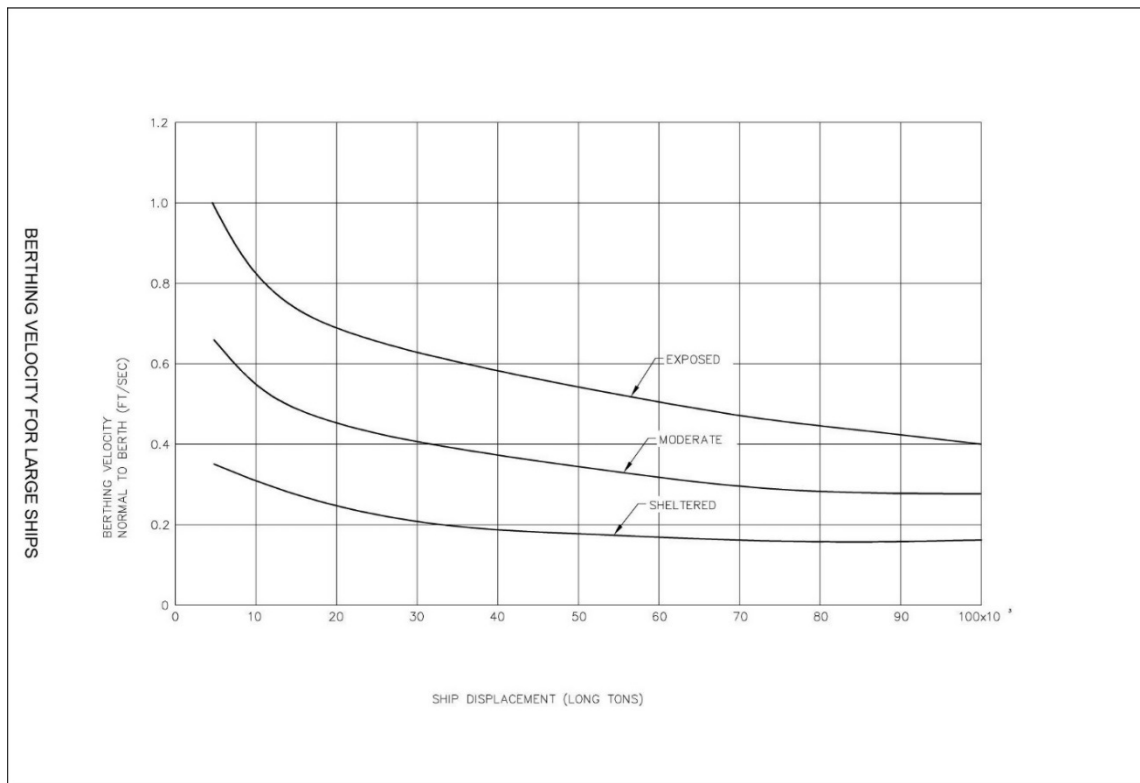

Figure 5-4 Berthing Velocity for Large Ship



5-2.1.2 Berthing Models.

- a. Statistical Method. This method is based on actual measurements of the energy of the impact at existing berths. This method is closely related to the conditions of the site where the measurements were taken and is dependent on the fender layout and construction, e.g., distance between piles, and the loading condition of the ship.
- b. Scale Model. This method, which makes use of a small-scale model test of the berth to be designed in a well-equipped hydraulic laboratory or ship model basin, suffers from the scale and viscosity effects and requires experienced interpretation.
- c. AQWA. NAVFAC EXWC typically uses the COTS AQWA software package to perform a dynamic analysis of berthing through six degrees of freedom in the time domain.
- d. Analytical Model. NAVFAC EXWC has developed an analytical model that can accurately predict ship berthing impact forces. The model employs a computational fluid mechanics approach, coupling a Reynolds-Averaged Navier-Stokes (RANS) numerical method with a six-degree-of-freedom motion program for time-domain simulation of ship and fender reactions. The model has been verified with data from small-scale and full-scale tests. Results from the new model for two ship classes yield added mass

coefficients close to those calculated by the PIANC formula as long as the depth-to-draft ratio exceeds 1.2. When the underhull clearance becomes small, i.e. for depth-to-draft ratios less than 1.2, predicted added mass coefficients can exceed the PIANC values. Added mass values of 5.0 or higher are predicted for ships berthing against open piers (pile supported) equipped with soft fenders, such as pneumatic or foam-filled cushions. Consider using higher values for the added mass coefficient under these conditions.

5-3 TYPES OF FENDER SYSTEMS.

5-3.1 General.

Fender systems absorb or dissipate the kinetic energy of the berthing ship by converting it into potential energy in the fender materials. This could be in the form of deflection of a fender pile, compression of a column of rubber, deformation of a foam-filled cylinder, torsion of a steel shaft, or pressuring of a pneumatic fender.

5-3.2 Fender Piles.

This is the most commonly used system in existing piers and wharves. This system is stiff and lacks the capacity for large deflection resulting in high reaction loads and frequent breakage of piling and hull damage. This system employs a series of closely spaced fender piles (5- to 10-foot spacing) (1.5 to 3 m) connected together by chocks and wales. A rubber fender unit is mounted between the wale and the berthing structure. A series of diagonal chains from the structure to the waler completes the system. Provide tight-fitting joints between chocks, wales, and pile head, with proper tension splices that provide compression and tension continuity along the face of berth. Ships may be berthed either directly against fender piles or by using additional fenders or camels between the ship and the fender piles. When camels are used, size the fender piling to resist the resulting bending and shear. In the working stress range, there is an approximate linear relationship between reaction force and deflection. When used with floating camels, which tend to cock between the ship and the piles, the ship's energy may become concentrated on just one or two piles. Hence, unless the floating camel is tightly secured to the piles (guided by piles), the system will not work well and frequent damage will occur. The pile-rubber fender unit is not recommended for solid and other types of piers and wharves where full deflection of the piles within the working range will be inhibited. When this system is employed throughout the length of berth, the rubber fender units should be sized for direct berthing of ships (without the use of camels).

5-3.2.1 Timber Fender Piles.

Timber fender piles have historically been the system of choice. Although timber fender piles are still in use, environmental concerns coupled with advances in other fender pile material, have led to a trend in replacement of this type of system. Further, in certain locations, timber fender piles may be susceptible to damage by marine borers.

5-3.2.2 Steel Fender Piles.

Steel HP sections, wide flange sections and pipes have been used for fender elements. These pile sections are typically coated and incorporate a cathodic protection system, a durable rubbing surface is required for fender systems, either UHMW-PE rubbing strips, or HDPE sleeves may be used to protect HP or pipe pile (PP) sections respectively. The typical steel system is comprised of steel HP or PP sections driven vertically and connected to a steel wale. The wale is attached to the supporting structure by a system of rubber fenders and chains.

5-3.2.3 Concrete Fender Piles.

Concrete fender piles are the most prevalent system in use. Square prestressed concrete fender piles have been tested and proven to have high-energy absorption fendering capabilities and greater strain energy at collapse than either timber or steel fender piling. They are typically 18 to 24 inches square (457 to 610 mm) prestressed concrete and have served well as primary fender piles for berthing and mooring. The fender piles are usually connected to a chock and wale system at the deck level and supported by rubber fender units at the bullrail. In the working stress range, there is a linear relationship between reaction force and deflection. Figure 5-5 shows a prestressed concrete fender pile installation. Additional guidance and design aids for concrete fender piles is contained in NCEL TM 53-89-03, *Prestressed Concrete Fender Piling User Data Package* and NCEL CR 89.005, *Prestressed Concrete Fender Piles: Fender System Designs*. In reviewing these documents the following is noted:

- Energy absorbing fender piles. The primary purpose of these piles is to absorb the berthing energy of a vessel and transfer the berthing reaction to the pier or wharf and harbor bottom. These piles were designed to be used with camels, but may be used without camels. Typically these piles are 18 inches (457 mm) square.
- Reaction fender piles. The primary function of these piles is to serve as a backing for foam filled or other marine fender units and to transfer the berthing reactions into the pier or wharf and harbor bottom. The foam filled fender is assumed to absorb all the energy required from vessel berthing. Energy absorption by the concrete piles adds to the system overload capacity. The reaction associated with the berthing energy is transmitted through the foam filled fender either directly into a row of closely spaced concrete reaction piles, or into a rigid bearing panel connected to concrete reaction piles at a greater spacing. The rigid bearing panel acts to distribute the reaction to the piles. Typically these piles are 24 inches (610 mm) square.

Figure 5-5 Foam-filled Fender System

Foam-filled fender, concrete fender piles, steel frame and polyethylene rub strips.
(*Marine Fender Systems*, by T.E. Spencer, ASCE PORTS 2004).



A test program conducted for concrete fender piles is documented in NCEL R-927, *Laterally Loaded Partially Prestressed Concrete Piles*. Key findings were:

- Partial prestressing to 600 psi (4137 kPa) (was sufficient to close flexural cracks).
- 18-inch (457 mm) square pile with twenty (20) 1/2 inch (13 mm) diameter prestress strands in a rectangular configuration confined by No. 3 ties with a 3-inch (76 mm) pitch performed best.
- 65-foot (19.8 m) lengths can be expected to perform well under cyclic load with an ultimate energy capacity of 30 ft-kips (41 kN-m) and a post ultimate capacity of more than 60 ft-kips (81 kN-m).

5-3.2.4 Composite Fender Piles.

There are two primary types of composite fender piles. One type of composite pile is made of fiber reinforced plastic (FRP) in the form of a tube that can be filled with concrete for greater strength and stiffness. Figure 5-6 shows an FRP fender pile system. Because of a higher susceptibility to abrasion and impact damage, the

thermoset FRP tube type pile should have rubberized abrasion strips installed at potential contact points with berthed vessels.

The second type of composite pile is made of thermoplastics (such as high-density polyethylene, HDPE) and reinforced with either steel or FRP strands. Figure 5-7 shows a plastic fender pile system. The reinforced thermoplastic type pile generally exhibit larger load-deflection properties compared to conventional wood, steel or concrete piles.

To ensure uniform loading and avoid premature failure of fender system components, these type piles should not be used in parallel or mixed with conventional type piles in the same system. Relevant work to date on composite fender piles includes TM-2158-SHR, *Study of Recycled Plastic Fender Piles*. Follow on work to this is contained in SP-2005-SHR, *Limited Flexural Tests of Plastic Composite Pile Configurations*, which includes flexural load tests to failure and cyclic tests to determine the stiffness (EI), load/deflection, linearity, hysteresis, energy absorption, degradation, and failure mode. Tests showed that composite piles absorb more energy than timber piles, but are not as stiff. This could pose a problem if the composite fender pile deflects too much. To date, composite piles have been used primarily for corner protection, as secondary fender piles, and as primary fender piles for small craft facilities.

Figure 5-6 Fiberglass Fender Pile System

Fiberglass fender pile, plastic pipe wear surface, top support and cap.
(*Marine Fender Systems*).



Figure 5-7 Plastic Fender Pile System

Plastic piles, plastic block, cylindrical rubber fender, and floating plastic log camel.
(*Marine Fender Systems*).



5-3.3 Fenders.

5-3.3.1 General.

The Navy has developed UFGS 35 59 13.16, *Marine Fenders* as the governing specification for selection of marine fenders.

5-3.3.2 Directly Mounted Fender Units.

In this system, individual fender units like the end-loaded, rubber shear, or buckling type, are attached directly to the pier or wharf face. For narrow tidal range in solid piers

and wharves, and for narrow vessel size range, this system may be cost-effective for direct berthing of surface ships. Although this system is very popular in commercial piers and wharves throughout the world, it may not be suitable for some DoD facilities. This system is subject to damage from snagging on ship protrusions at levels of 8 to 10 feet (2.4 to 3 m) above the water line and from vertical loads resulting from snags on rails and protrusions during falling tides or from lateral loads due to snags on protrusion during longitudinal movement of the ship.

- a. End-Loaded Rubber Fenders. These work by elastic compression of hollow rubber cylinder elements with small length-to-diameter ratios. As shown in Figure 5-8(A), steel fender panels with special rubbing material facing are usually required to minimize wear. The reaction force is an exponential function of the deflection. These fenders are usually attached directly to the pier or wharf structure in the form of a "cell fender."
- b. Side-Loaded Rubber Fenders. These are hollow rubber units available in trapezoidal, circular, square, or D-shapes that, when loaded at their side, deform by trying to flatten out. See Figure 5-8(B). The potential energy is stored by a combination of compression and bending of the rubber elements. The reaction force is an exponential function of the deflection and the performance curve is quite similar for all the shapes. Fenders having a curved rather than flat external surface increase in stiffness more gradually as the area of contact increases during deformation. All these fenders experience a sharp and rapid increase in stiffness when the amount of deflection completely collapses the open bore, regardless of their external contour.

Side-loaded rubber fenders will not absorb large amounts of energy and generally are not used alone. They are usually provided at the top of fender piles between the wale and berthing structure. A series of diagonal chains from the structure to the wale completes the system. When used with tight fitting joints between chocks, wales, and pile head, and when proper tension splices that provide compression and tension continuity along the face of the berth are used, the system has worked very well in both naval and commercial facilities. Ships may be berthed either directly or a floating camel may be used. When camels are used, size the fender piling to resist the resulting bending.

Prestressed concrete, steel, and timber have been used successfully with side-loaded rubber fenders. This type of system provides good berthing flexibility. Ships of different sizes, tug boats, submarines, and barges can be accommodated without any modification.

- c. Rubber Shear Fenders. The potential energy in these units is stored as elastic shear deformation of the rubber. Usually, a solid rubber block is vulcanized between two metal plates and the force is transferred through a fender frame or panel, as shown in Figure 5-9. These fenders are highly sensitive to proper manufacturing and installation as they depend on the bond

- between steel plates and the rubber. The force-deflection relationship is essentially linear.
- d. Buckling Fenders. These fenders operate on the buckling column principle, in which a molded column of rubber is loaded axially until it buckles laterally. The end-loaded cylinder fenders described earlier are actually a buckling fender in principle. Most buckling fenders are not well suited for direct contact with a moving ship and hence are used with an abrasion or protector panel, as shown in Figure 5-10. The reaction force is linear up to a level when the pure compression behavior changes to the buckling mode. Hence, initially a relatively high reaction is built up with a small deflection, which then stays constant through the rest of the deflection range. Because buckling fenders are intended to buckle in a predetermined direction, any lateral deflection can significantly reduce their effectiveness. When lateral loads in either direction (parallel to length of berth or up/down) are anticipated, a cell-type fender is preferred. These fenders are becoming increasingly popular for berthing very large ships as they can absorb very high energy with a constant reaction force.

Figure 5-8 Side-loaded and End-loaded Rubber Fenders

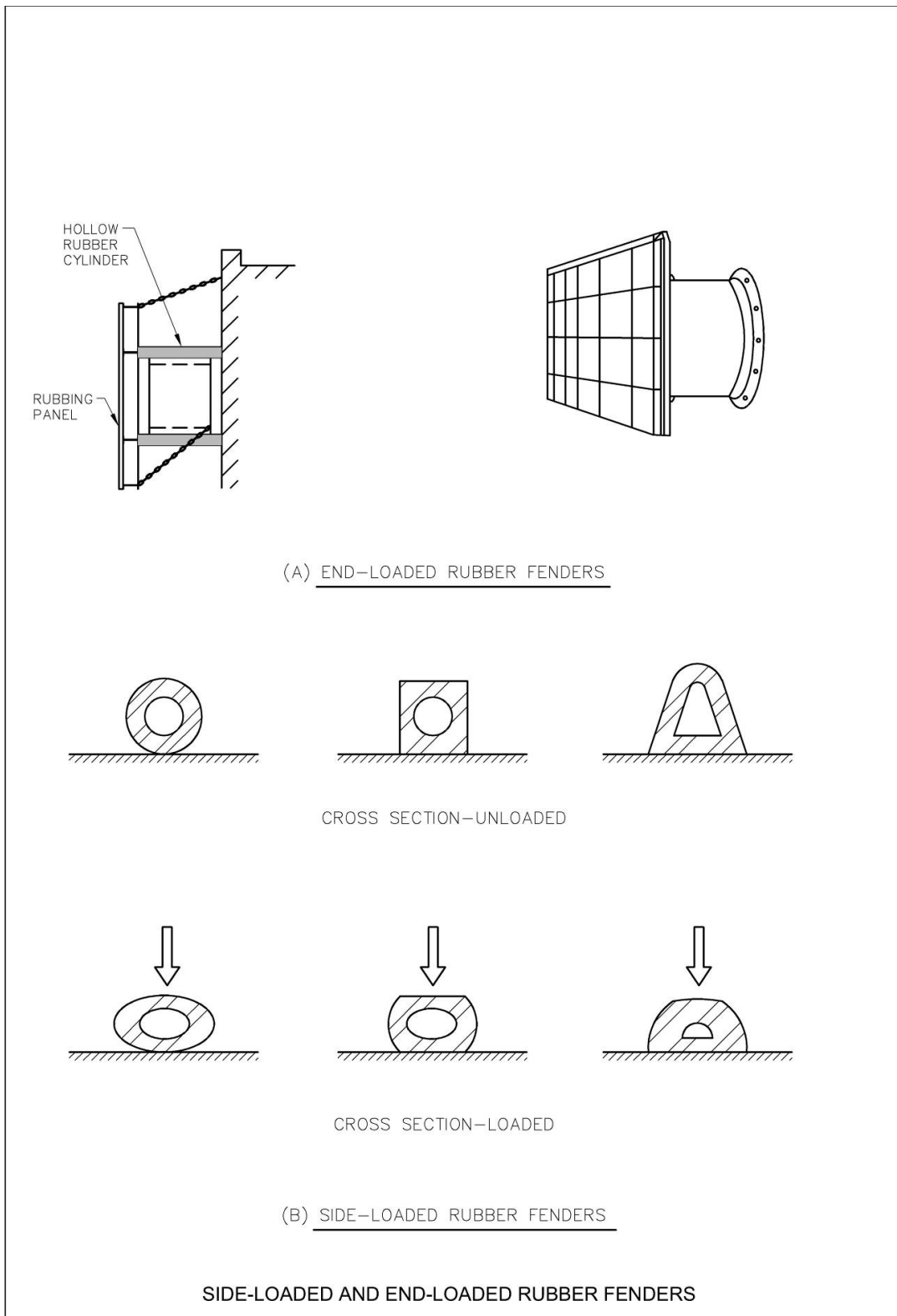

Figure 5-9 Shear Fender

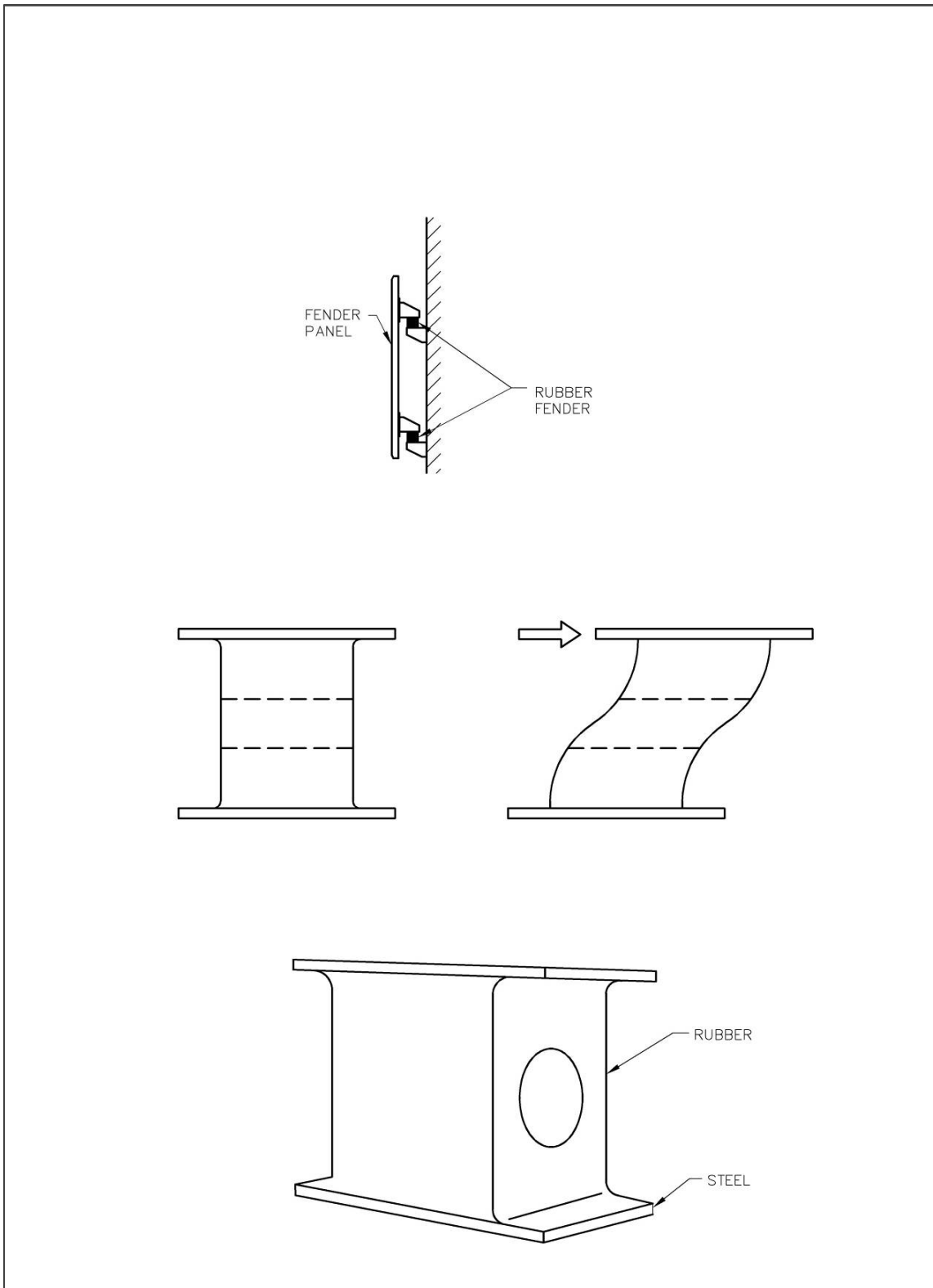
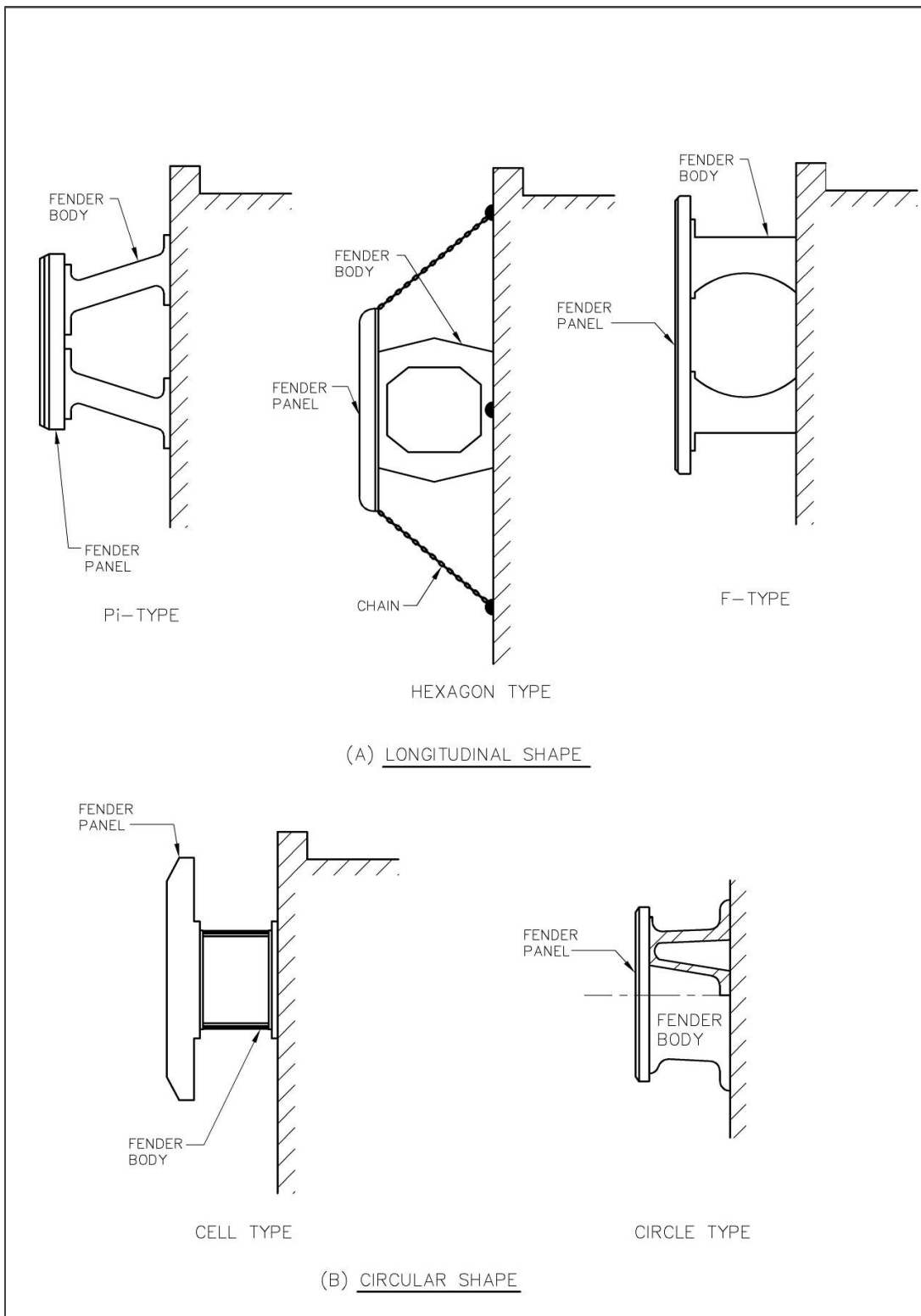

Figure 5-10 Buckling Fender with Contact Panel



5-3.3.3 Floating Fender Units.

This system consists of pneumatic or foam-filled fender units and a backing system. As the fender units can be positioned to float with the tide, most surface ship types can be handled. Design the backing system to work with the fender unit for the full tidal range. Because the floating units are usually rather large, they provide a good standoff. The berthing structure may be designed with the backing system at different points along the length of berth and the fender units moved around as berthing plans change. When clustered piles or sheet piles are used for the backing system, additional energy can be absorbed by the piles and their support systems at the deck level.

- a. Pneumatic / Hydro-Pneumatic Fenders. The potential energy in these fenders is stored by the elastic compression of a confined volume of air. By varying the internal pressure of air, the energy-absorption characteristic can be changed. To prevent the air pressure from increasing to a "blowout" level, pneumatic fenders are provided with a relief valve or deflection limiter within the body of the unit. The shell construction for these fenders is similar to an automobile tire with several laminations to provide the high tensile strength required. The surface pressure of these fenders is uniform, resulting in uniform hull pressure. Reaction force is an exponential function of deflection. The basic types of pneumatic fenders in common use are discussed below:
 - Air Block and Air Cushion. The shells for these are chemically bonded and mechanically coupled to a rigid mounting plate that can be attached to a solid face of the berthing structure. See Figures 5-11(C) and 5-11(D).
 - Floating. The floating type is usually cylindrical in shape with hemispherical ends and is attached to the structure by chains. It floats on the water and rises and falls with the tide. The unit requires a backing system to distribute the load. As shown in Figures 5-11(A) and 5-11(E), large floating pneumatic types are sometimes covered with a net of used automobile tires and cylindrical rubber sleeves to protect the fender from puncture and abrasion. The tire net and chains also form the means for rigging and attaching the fender to the pier.
 - Tire. This type consists of a large-diameter tire mounted on an axle and backed by rollers. The unit can be mounted with its axis of rotation vertical or horizontal. This type is particularly suited for pronounced corners of the structure where ships may have approach difficulties. See Figure 5-11(B).
 - Hydro-Pneumatic. This type of fender has been developed for use with submarines and consists of a vertically mounted cylindrical pneumatic fender partially filled with water and backed by a closely spaced group of fender piles. A ballast weight is added to adjust the degree of submergence of the fender to coordinate the vertical center of the fender with the horizontal center of the submarine hull; see Figure 5-12. The fender unit floats with the tide and therefore stays in the same relative position with the vessel.

Figure 5-11 Pneumatic Fenders

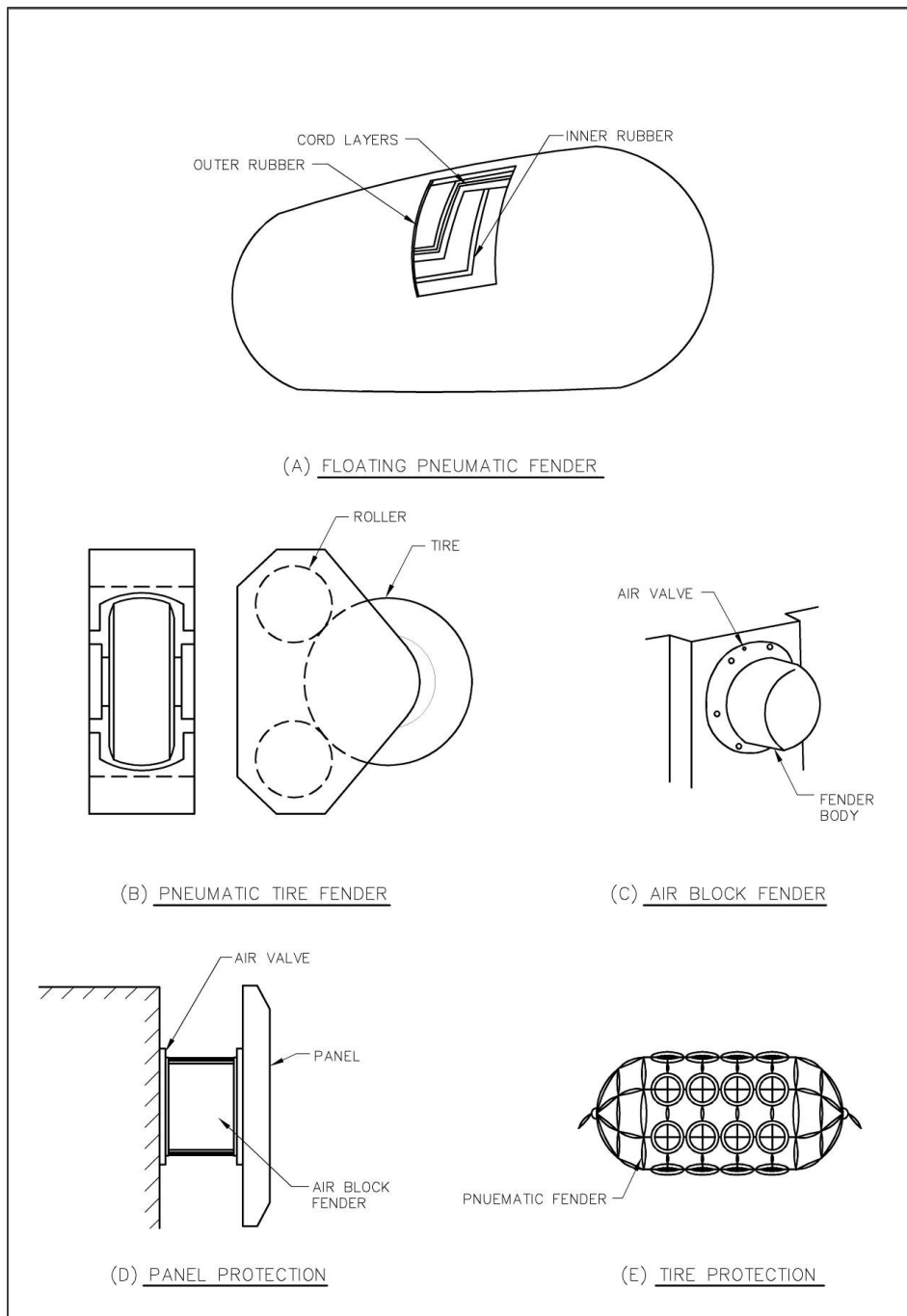

Figure 5-12 Hydro-pneumatic Fender

Hydro-pneumatic fender and counter weight being installed.
(*Marine Fender Systems*).



- b. **Foam-Filled Fenders.** These are constructed of resilient, closed-cell foam surrounded by an elastomeric skin. Provide additional protection against abrasion by thicker elastomeric coatings or an external tire net, similar to the floating pneumatic type. The fender requires a backing system to distribute the load. Netless fenders cost more due to the need for thicker skins and coatings. However, the greater hull marking of the tire net and occasional maintenance need suggest that netless fenders may be preferred. The unit can either be utilized as a floating fender, moving up and down with the tide and held in place with chains or can be suspended from the pier/backing system. The cellular structure of the foam filling reacts like hundreds of millions of individual pneumatic fenders in deforming and absorbing the energy. The foam contains the air within its cellular structure and tends to compress upon itself rather than bulge peripherally. The foam-filled fenders have a high-energy absorption with comparatively small reaction force. Surface pressure of the fender is not quite uniform when it is compressed, so the hull pressure over the contact area is not quite uniform. Where rough concrete surfaces of the backing surface or prestressed concrete piles is a

concern, use UHMW pads or strips to protect the skin of the foam filled fender. See Figure 5-5 for a typical foam-filled fender installation.

5-3.3.4 Combination System.

Any of the above-mentioned fender systems may be combined in the same berth. A berth may have either the floating fender units or directly mounted fenders at discrete points, with the in-between spaces filled up by the pile-rubber system designed to work with camels. Floating fenders and directly mounted fenders may be used alternately along solid or open types of piers and wharves.

5-3.3.5 Monopile System.

This fendering system is based on the use of a floating ring-shaped resilient fender unit that rides up and down on a large steel pile driven to the seabed. Special low-friction bearing pads are usually installed on the inner surface of the hull of the ring fender so that the fender unit can rotate and slide freely on the pile. This unique ability makes the monopile system very suitable for corner protection of piers and wharves and entrances to a narrow slip. The units can also work well as breasting and turning dolphins. Energy is absorbed both by the steel monopile in flexure and by the ring-shaped fender unit. This system is illustrated in Figure 5-13.

5-4 SELECTION AND DESIGN OF FENDER SYSTEMS.

5-4.1 General.

The major factors influencing the selection of the best fender system for a particular situation include the following:

5-4.1.1 Energy-Absorption Requirements.

Provide the fender system with sufficient energy-absorption capacity to absorb the kinetic energy of the berthing vessel.

5-4.1.2 Reaction Force.

This is the force that is exerted on the berthing structure during impact. The reaction force has a significant effect on the design of the berthing structure.

5-4.1.3 Hull Pressure.

This is the pressure exerted on the ship's hull by the fender unit and is derived by dividing the reaction force by the fender area in contact with the ship. Limit hull pressure to levels that will not cause permanent damage to the berthing ship.

5-4.1.4 Deflection.

This is the distance, perpendicular to the line of the berth that the face of the fender system moves in absorbing the ship's kinetic energy. The magnitude of the allowable deflection will be controlled by other protrusions from the berthing face and the ship.

Figure 5-13 Monopile Fender System

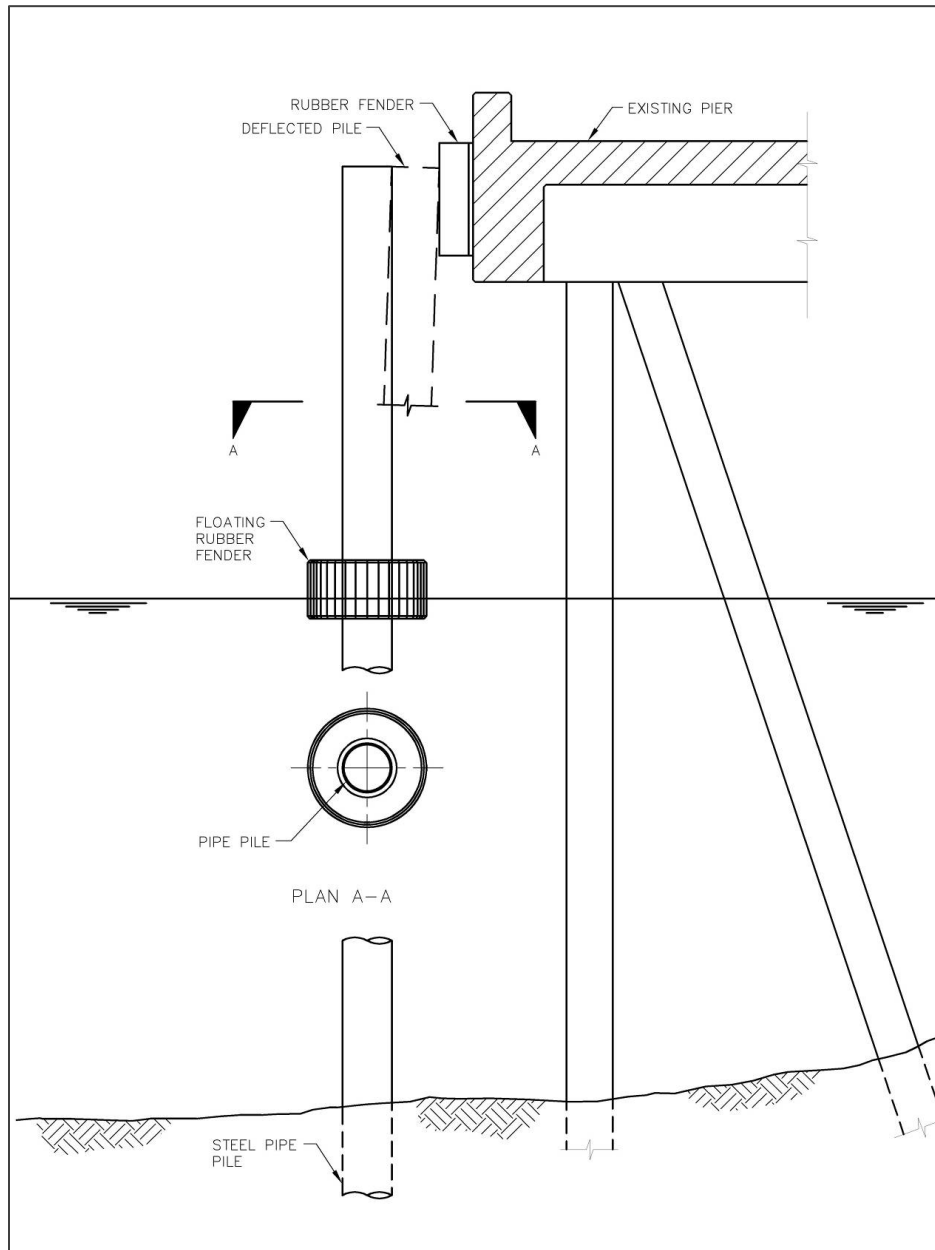

5-4.1.5 Reaction/Deflection Relationship.

The nature of the reaction deflection relationship determines the relative stiffness of the fender system.

5-4.1.6 Long-Term Contact.

This includes the changes in environmental conditions (i.e., wind, current, waves, and tide) during loading and unloading at the berth. The fender system should not "roll up," tear, abrade, or be susceptible to other forms of damage when subject to long-term contact.

5-4.1.7 Coefficient of Friction between the Face of the Fender System and the Ship's Hull.

This determines the resultant shear force when the ship is berthing with longitudinal and/or rolling motion and may have a significant detrimental effect on the energy-absorption performance of the fender system. The magnitude of the shear force also may have a significant effect on the cost of the berthing structure.

5-4.1.8 Degree of Exposures.

Where the berth is exposed to severe wind, current, and/or wave action, the fender selection may be governed by the design mooring conditions rather than berthing conditions.

5-4.1.9 Life-Cycle Costs.

Evaluate capital costs for both the fender system and the structure; also evaluate costs for operation, maintenance, and repair.

5-4.1.10 Berthing Practice.

The capability of the crews responsible for berthing the ship will have an effect on the energy-absorption requirement of the fender system. The berthing velocity and angle of approach are affected by the local berthing practice.

5-4.1.11 Maintenance.

Where maintenance is expected to be infrequent, a simple, possibly less efficient, fender system may be preferable to a system requiring a higher degree of maintenance.

5-4.1.12 Local Experience.

Consider fender types already used locally because their performance under actual conditions is known. Also, there may be an advantage in having interchangeability of spares, particularly if the number of new fenders required is small.

5-4.1.13 Frequency of Berthing Operations.

A high frequency of berthings normally justifies greater capital expenditures for the fender system.

5-4.1.14 Range of Ship Sizes Expected to Use the Berth.

While the energy-absorption capacity of the fender system may be selected for the largest ship expected to use the berth, ensure that the fender system is suitable for the full range of ships that the berth will accommodate. The effect of hull pressure and fender stiffness on the smaller vessels may have a significant influence on the selection and arrangement of the fenders.

5-4.1.15 Shape of Ship's Hull in Contact with the Fender System.

Where vessels with unusual hull configurations or protrusions are expected to use the berth or where the berth accommodates barges, pay special attention to the selection and arrangement of the fender system.

5-4.1.16 Range of Water Level to be Accommodated.

Consider the full range of water levels that may occur at the berth. Consider both the largest and smallest vessels, in both the loaded and light conditions, at high and low water levels. Where extreme water level variations occur, consider using floating fender systems.

5-4.1.17 Camels.

The size, type, and number of camels used in berthing operations will seriously influence selection of the fender system.

5-4.2 Fender System Behavior.

The fender systems having the most promise for new installations can be classified into three groups in terms of their behavior:

5-4.2.1 Flexible Pile Types.

The flexible pile types, or various fender piles discussed earlier, have basically a linear force-deflection relationship. Cantilevered piles or "monopile" systems likewise have a basically linear force-deflection relationship.

5-4.2.2 Buckling Column Types.

The buckling column types behave linearly up to a point where the rubber starts to buckle and behave nonlinearly from there on. Because the buckling type fender systems have the highest energy-absorption capacity for a given deflection and reaction, they are in very wide use in commercial piers and wharves. Due to the nature

of the reaction/deflection/energy-absorption relationship of these types of fenders, a very high reaction (close to maximum) occurs during virtually every berthing operation. Design the berthing structure with this fact in mind. This fact also causes the fender to be relatively rigid when smaller ships use a berth designed for larger ones.

Many buckling-type fenders cause rather high contact pressures against the ship's hull and consequently require a panel to distribute and thus reduce the pressure. Size and locate the panel to ensure proper contact with both the largest and smallest vessels to use the berth. Another characteristic of these fenders to consider is their lowered performance when impacted by a vessel approaching at an angle to the berth or with a velocity component in the longitudinal direction. The reduction in energy-absorption capacity may be as much as 20 percent when the approach angle is 5 to 10 degrees, with additional reduction when combined with shear strain.

5-4.2.3 Pneumatic, Foam-Filled and Side-Loaded Rubber Fenders.

The pneumatic, foam-filled, and side-loaded rubber fenders exhibit very similar behavior with the reaction force building up more than proportional to increasing deflection. The floating pneumatic and foam-filled fenders have a similar appearance and similar reaction/deflection relationship. Compared to the buckling types, these fenders require greater deflection for a given reaction and energy-absorption capacity. Further, the pneumatic and foam-filled fenders present a relatively larger surface to the ship's hull and consequently have lower hull contact pressures. This eliminates the need for a panel between the ship and the fender. With the pneumatic and foam-filled types of fenders, the maximum reactions will normally occur only a very few times during the life of the facility, permitting the use of higher stress levels in the supporting structure. However, they require a rather large, solid face on the supporting structure, which may increase its costs. The main difference between pneumatic and foam-filled fenders is that the first will lose its strength completely when punctured by ship protrusions and that the latter may lose a significant part of its energy-absorption capacity under repeated heavy loadings.

5-4.3 Evaluation of Fender Systems.

5-4.3.1 Equal Energy and Reaction.

Figure 5-14 (A) illustrates the reaction-deflection characteristics of the three types of fender systems. The area under each of the reaction/deflection curves represents the energy absorbed by that type of fender. Each of the curves in the figure represents fender systems with equal rated reactions and equal energy-absorption capability. It is evident from the figure that, while the fenders of the various types illustrated provide equal energy absorption at equal rated reactions, the energy-absorption capacity is achieved through different deflections, with the buckling type deflecting the least.

5-4.3.2 Equal Reaction and Deflection.

A comparison of the various types of fenders may alternatively be considered on the basis of equal rated reaction and equal deflection, as illustrated in Figure 5-14 (B). This situation often occurs when new fender units are installed in conjunction with, and compatible with, an existing fender system. It may also occur when a replacement fender system is installed in an existing facility with cargo transfer equipment of limited reach. It is evident from the figure that the buckling type fenders have considerably more energy-absorption capacity for the same reaction and deflection than the other types.

5-4.3.3 Reaction versus Energy Absorbed.

Comparing the various types of fender systems from the point of view of the reaction force that is developed for a given energy-absorption capacity, as illustrated in Figure 5-14 (C), it is evident that the pneumatic, foam-filled, and side-loaded rubber type fender units are the "softest." They have greater energy-absorption capacity at reaction levels less than their maximum rated reaction. This characteristic makes these fenders particularly attractive at berths that expected to accommodate a wide range of vessel sizes because the fenders will deflect significantly even when subjected to relatively small berthing impacts.

5-4.3.4 Accidental Overloads.

Also to be considered in the selection of a fender system is the consequences of an accidental overload of the system. The buckling and side-loaded rubber fenders "bottom out" if compressed beyond their maximum rated deflection, with resultant high reaction forces and the potential for severe damage to the berthing vessel and the support structure. The reaction of flexible pile fender systems will continue to increase at a uniform rate when overloaded until the yield stress of the pile material is reached, at which point continued deflection will occur as the material yields with no appreciable increase in reaction. Foam-filled fenders, when compressed beyond their maximum rated deflection, will exhibit a steadily increasing reaction and will incur permanent deformation and consequent loss of future energy-absorption capacity. The pneumatic fenders are normally fitted with relief valves so that when overloaded they continue to absorb energy with no increase in reaction beyond that which corresponds to the relief valve setting and no permanent damage to the fender unit.

Figure 5-14 Evaluation of Fender System Types

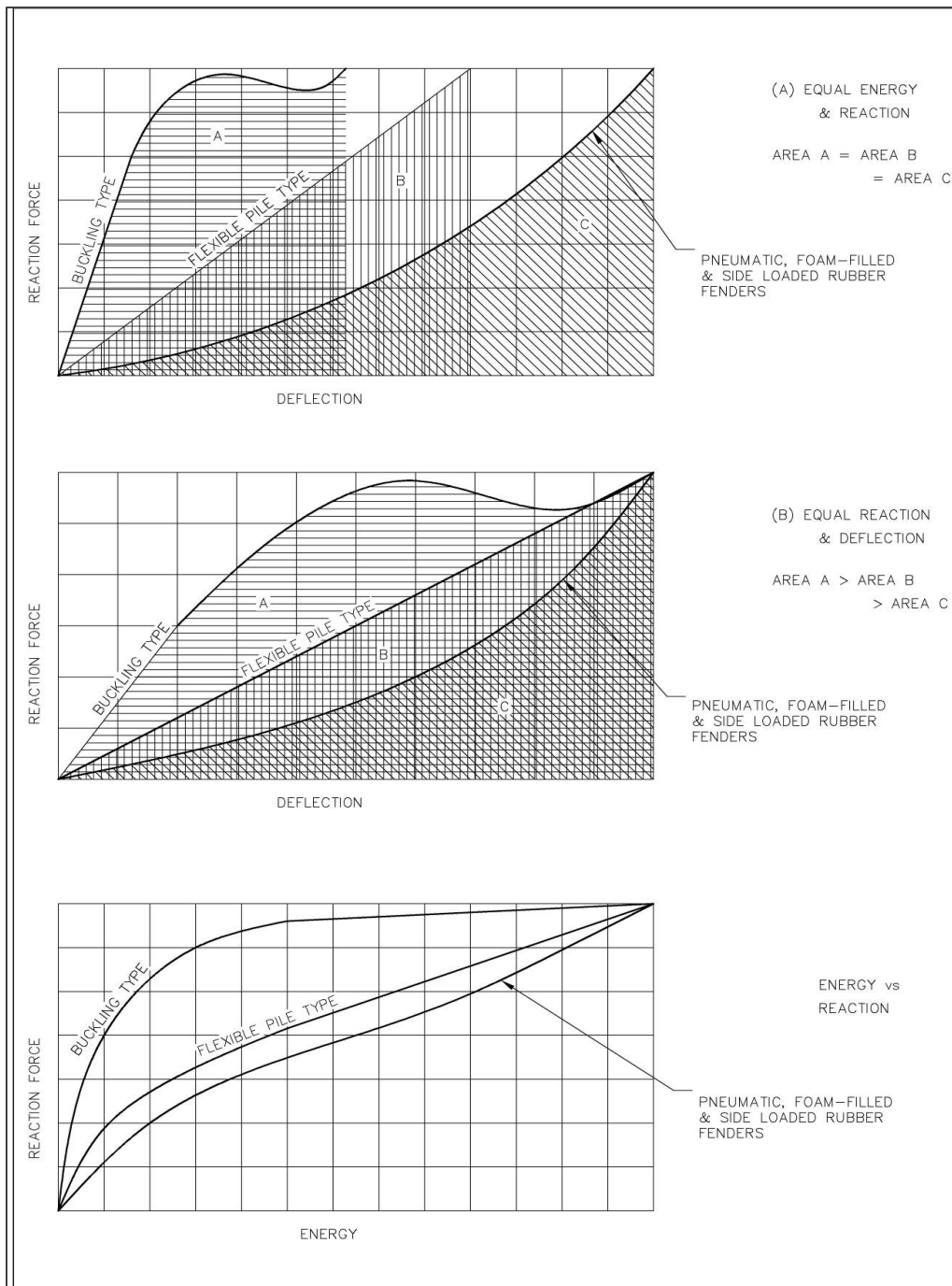

5-4.4 Fender System Design.

5-4.4.1 Ship Contact.

While the ideal berthing process would attempt to engage as many fender units as possible, in reality, at the time of impact, the ship will be at a slight angle to the berth and contact will be made over a small length. Design discrete fender units such as the buckling column type or the floating type, for one unit to absorb the full energy with a minimum of two units installed per berth. For the continuous system using flexible piles and fenders, the length of contact will be a function of the ship's hull radius at the level where contact is made, the flexibility and spacing of fender units, and the stiffness of the chock and wale assembly in the horizontal plane. The problem is analogous to a beam on an elastic foundation. In the absence of more rigorous analysis, the following assumptions for contact length may be made:

- 20 feet (6.1 m) for cruisers, destroyers, and frigates.
- 40 feet (12.2 m) for amphibious warfare ships, and auxiliary ships.

When berthing is made with camels, assume only one camel to be in contact at the time of impact, with a minimum of two camels installed per berth. Where the camels are guided by fender piles, assume all the piles to be effective in sharing the energy. When free-floating camels are used, not all the piles backing the separator will be effective. Local experience should dictate and a more conservative assumption should be made.

5-4.4.2 Allowable Hull Pressure.

When the ship's energy is resisted through foam-filled or pneumatic fenders, the resulting force is concentrated in a small area of the ship's hull. In such cases, the allowable pressure on the ship's hull becomes a critical design issue. Most surface combatants have a thin hull plating with a low allowable hull pressure. For more specific information on the ships being berthed, consult NAVSEA. See TR-6015-OCN, *Foam Filled Fender Design to Prevent Hull Damage*, and note that values in Table 7 are based on yielding of the hull plating and include a 1.5 safety factor. Consequently, when checking for an accidental condition, the allowable value for hull pressure may be increased by up to 50 percent.

5-4.4.3 Allowable Stresses.

Because ship berthing is a short-term impact type of loading, the following increases over previously published values are permitted.

- a. Timber. For operating condition, the allowable stress in flexure (tension and compression) may be taken as 0.67 times modulus of rupture or the published allowable values increased by a factor of 2.0, whichever is less. For the accidental condition, the stress-strain curve may be assumed to be linear up to 0.9 times modulus of rupture, which should be taken as the limit.

- b. Steel. For operating condition, the allowable stress in flexure (tension and compression) may be taken as 0.8 times yield stress. For the accidental condition, full yield stress may be used. However, the sections used should satisfy compactness requirements or the allowable stress reduced proportionately. Members should be sufficiently braced for development of the yield strength.
- c. Concrete. Design reinforced and prestressed concrete members not intended for energy absorption with a load factor of 1.7 over forces developed due to operating condition; they will be satisfactory for the accidental condition. Do not allow further prestressed members to develop tensile stresses in excess of $12 f'_c$ (f'_c = 28-day compressive strength) in the precompressed zone. Prestressed concrete members specifically designed for energy absorption will have a maximum allowable working energy (E_{wc}) equal to 0.67 times the applied load (P) times the deflection at the point of the applied load. Satisfy the following three criteria to determine the maximum allowable working energy (E_{wc}) in the pile section for a given length:
 - Maximum concrete compressive strain equal to or less than 0.0021 inch/inch (0.0021 mm/mm).
 - Maximum stress in the prestressing steel at working energy equal to or less than 210,000 psi (1 447 899 kPa).
 - The working energy (E_{wc}) no more than 2/3 of the nominal pile energy (E_{nc}). This provides a minimum factor of safety of 1.5 in case of overload of the pile.

5-4.4.4 Coefficient of Friction.

As the ship is berthed against the fender system, there will be force components developed in the longitudinal and vertical directions also. As the coefficient of friction between rubber and steel is very high, special fender front panels have been developed with reduced friction coefficient. Ultra high molecular weight (UHMW) plastic rubbing strips have been successfully used in front of timber piles. The following friction coefficients may be used in the design of fender systems.

- Timber to steel..... 0.4 to 0.6
- Urethane to steel..... 0.4 to 0.6
- Steel to steel..... 0.25
- Rubber to steel..... 0.6 to 0.7
- UHMW to steel..... 0.1 to 0.2

5-4.4.5 Temperature Effects.

Fender piles, backing members, etc., are not affected by temperature fluctuations and can be expected to perform normally. However, in colder temperatures, rubber fender

units become stiffer and their performance will be affected significantly. Hence, evaluate the energy-absorbing capability of the rubber unit and the fender system as a whole based on the lowest operating temperature expected. Carefully design and detail UHMW rubbing strips which have a significantly higher rate of expansion than steel or concrete to operate effectively.

5-4.5 Corner Protection.

Provide all corners of piers and wharves and entrances to slips with fender piles, rubbing strips, and rubber fenders for accidental contact with ships or routine contact with tugs. Use any of the different types of fender piles mentioned. See Figure 5-15 for typical details.

5-4.6 Support Chains.

Chains are commonly used in fender systems when a tension member is needed. Chains are used in continuous fender systems and large buckling and cell type units to resist the sudden energy released. For pneumatic and foam-filled resilient fender units, the chain is used to suspend the units. Chain smaller than 3/8 inch (9.5 mm) is not recommended. For better corrosion resistance, zinc coating is preferred. A common weldless high-test chain is usually more cost-effective than the stud link variety.

5-4.7 Chocks and Wales.

For selection and design of chocks and wales refer to SP-2045-SHR, *Proposed Design Criteria for Chocks and Wales*.

Figure 5-15 Corner Protection

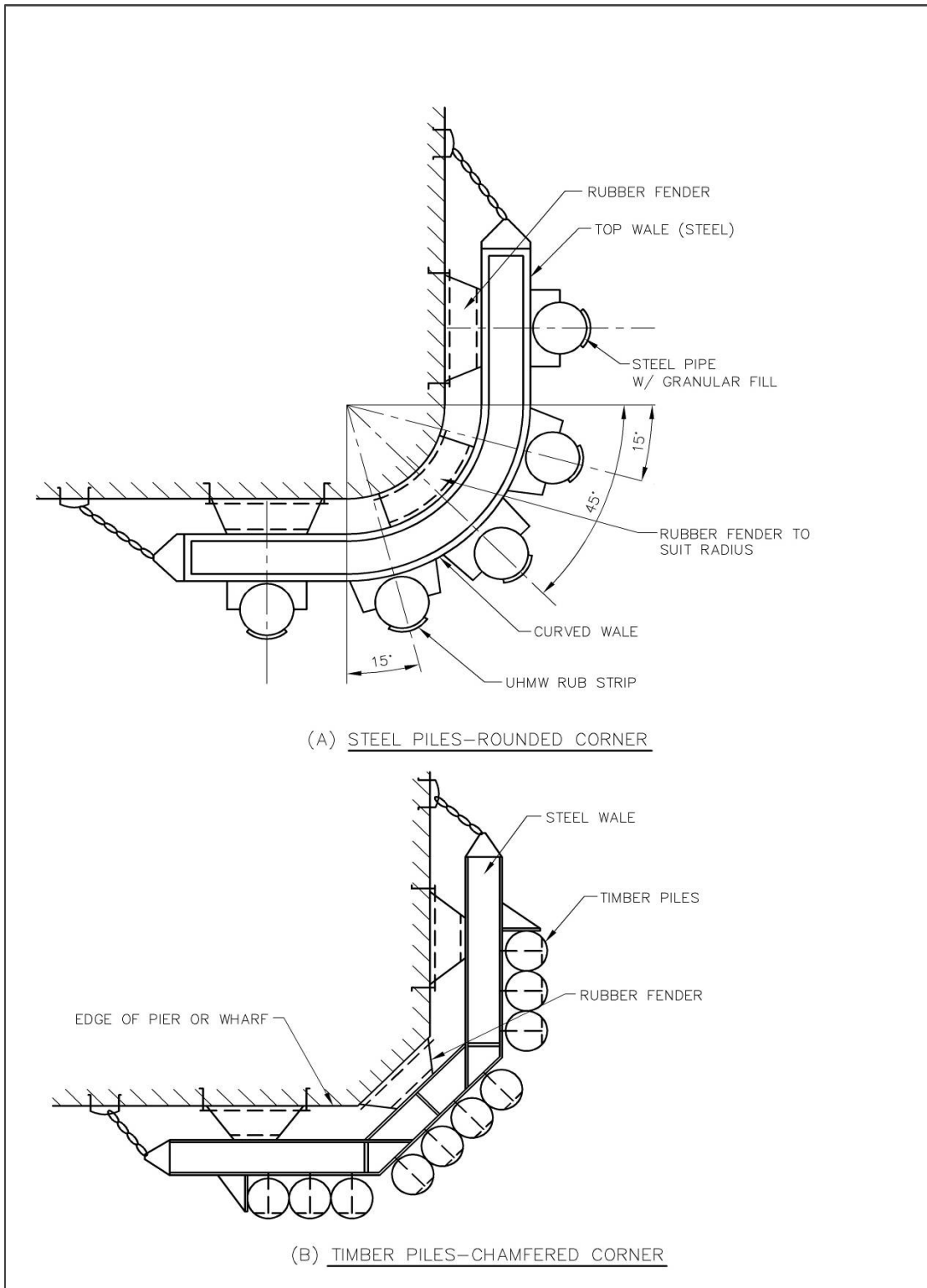

This Page Intentionally Left Blank

CHAPTER 6 CAMELS AND SEPARATORS

6-1 FUNCTION AND APPLICATION.

Camels are structures used between the ship and the pier/wharf. Camels are a NAVFAC design responsibility. Separators are structures used between adjacent multiple berthed (nested) ships to provide a "standoff" or separation. Separators are a NAVSEA design responsibility. As mentioned in the previous section, design of fender piles or other backing system is required to provide the structural interface between the camel and the pier/wharf structure. Camels and separators are used at piers and wharves for the following reasons.

6-1.1 Hull Maintenance.

During active berthing, the ship's crew typically performs cleaning, painting, light hull repairs, and other routine maintenance activities on the ship. These activities are best performed when the ship is kept off the structure at discrete points.

6-1.2 Overhangs and projections.

Aircraft carriers that have large overhangs at the flight deck level, and several other ship types having bulges and projections at the side, require camels to prevent damage to the ship at these projections. Other protrusions include air masker bands, soft sonar domes, and stabilizer fins.

6-1.3 Special Hull Treatments.

Some ships are equipped with special hull treatments that can get damaged through constant rubbing against the structure. Camels and separators with rub strips can minimize the contact area and control the damage.

6-1.4 Submarine Berthing.

Navy submarines are typically berthed using camels. The submarines may be moored to the camels or moored directly to the berthing structure. Submarines require the camels to prevent damage to diving planes, screws, fairings, and the special hull treatments. Specifically, camels should not interfere with the Wide Aperture Array (WAA) found on some submarines. Further, special attention may be required for submarines equipped with the Conformal Acoustic Velocity Sonar (CAVES). These systems may require the camels to be located in specific locations. Develop berth specific camel mooring plans and coordinate with SUBFOR.

6-1.5 Multiple Berthing (Nesting).

Separators are required between ships that have to be berthed abreast for ship-to-ship transfer operations or for lack of berthing space at a naval station.

6-1.6 Fender Protection.

When the existing fender system can suffer damage due to motions of moored ships, a camel can be useful in reducing the damage as long as it is properly placed and the ship is properly moored.

6-2 CAMELS.

Experience has shown that camels left unattended in the vacant (no vessel present) condition at a berth can be subjected to damage from action by wind and waves, depending upon the degree to which the berth is sheltered. For this reason, a site specific study should be prepared for each berth where camels are to be utilized. The study should look at: environmental conditions, i.e. wind/wave climatology and vessels expected to utilize the berth. Procedures should be developed detailing how the camels will be moored and secured in place to include measures to buffer the camel face contacting the berth in order to prevent damage to the camel.

6-2.1 Log Camels.

These are large-diameter logs (24- to 36-inch (610 to 914 mm) diameter, 40 to 50 feet (12.2 to 15.2 m) long) held in the desired position from the deck by nylon ropes or chains. They are usually allowed to float with the tide. The longer length is preferred as they can distribute the load to a greater number of piles. Multiple log camels are made from several smaller diameter logs held together by wire rope at ends and at center. They are not as efficient as the single log camels. Plastic coated steel pipes have also been used successfully as camels. The pipe core is generally filled with foam to ensure positive flotation. Log camels fabricated from recycled plastics and composite materials are available. Sometimes a series of used tires may be fitted through the log to provide some energy absorption. Log camels do not provide much of a separation. When a wider separation is needed, other types of camels are more appropriate. Consider marine growth as it relates to log camel buoyancy.

6-2.2 Timber Camels.

These consist of several large timbers connected together by struts and cross braces to form a large crib. Additional flotation units may be inserted between the timbers for a higher freeboard. Wear causes bolt heads to become exposed and thus cause damage to hulls.

6-2.3 Steel Pontoon Camels.

These are made of cubical or cylindrical steel pontoons connected by structural framing. The pontoons should preferably be filled with foam to reduce the risk of losing flotation by accidental puncturing of the units.

6-2.4 Deep-Draft Camels.

For submarine berthing where a good portion of the body is below the waterline, all the above camels are inadequate, as the camel will ride up on the submarine during berthing. Hence, deep-draft camels have been developed. They have limited energy absorption and a narrow working platform. These camels work well when mooring against a tender ship and for multiple berthing. When used against an open pier or wharf, these camels will require solid backing elements (below waterline) from the fender system. A typical deep-draft camel is shown in Figure 6-1.

Figure 6-1 Deep Draft Camel (NAVFAC drawing 100400035)

(Drawing By: B. Deneke)

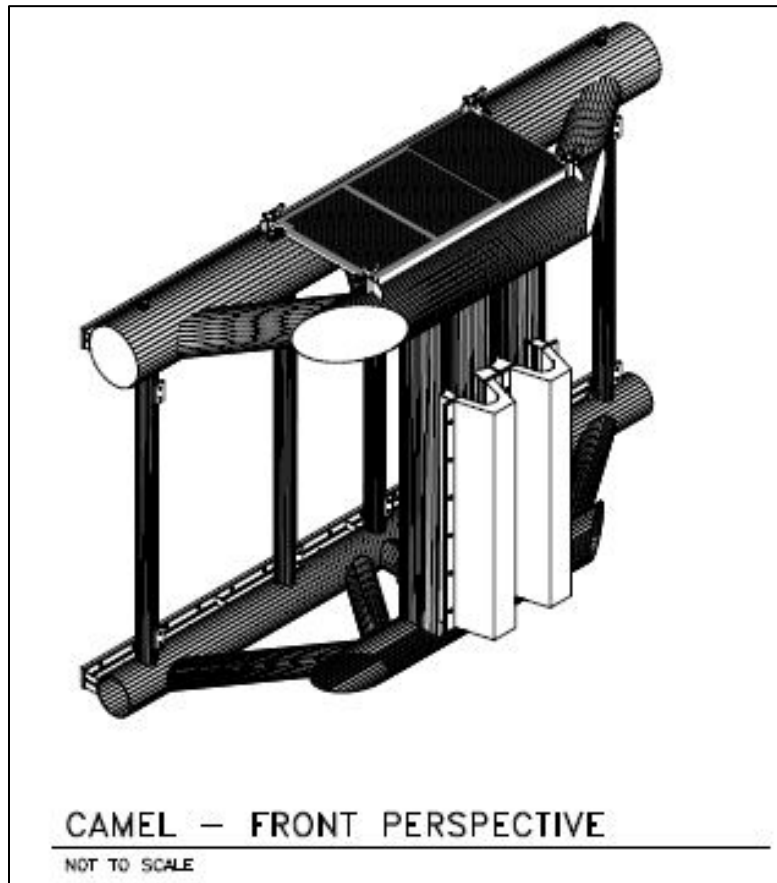

6-2.5 Hydro-Pneumatic Fenders.

Although discussed previously under the section: Floating Fender Units, this type of fender has been used as a camel for submarines at a number of locations. One of the principle reasons for preparing the report, TR-6064-OCN, *Berthing Guidelines for Submarines*, was to investigate hydro-pneumatic fenders in terms of providing adequate clearance for the submarine's stern planes. Based upon the findings in this report, 14.8

feet (4.5 m) diameter hydro-pneumatic fenders are recommended in lieu of 10.8 feet (3.3 m) diameter hydro-pneumatic fenders.

6-2.6 Composite Camels.

NAVFAC EXWC developed a composite camel for use in berthing submarines. The camels are manufactured from composite materials intended to provide an extended service life over steel construction. The camels were developed and funded under a NAVFAC RDT&E effort and have been successfully used at SUBASE New London since mid-2000. Subsequently, a NAVFAC standard design has been developed and can be obtained at: <http://www.wbdg.org/ffc/navy-navfac/cad>. Universal composite submarine camels are shown in Figure 6-2.

Figure 6-2 Universal Composite Submarine Camel



6-2.7 Loads.

The camel loads are computed from berthing and mooring analysis of the ship, camel, fender, and structure system resisting the lateral loads. All the ship's berthing reaction loads as well as current and wind loads are transmitted through the camels to the pier or wharf structure. Assume all horizontal loads to be acting uniformly along the length. Design deck elements of large camels for 50 psf (2.4 kPa) vertical live load. Check the camel assembly for fabricated camels for lifting stresses. Where the pick-up points and rigging configurations are critical to control lifting stresses in the camels, provide clearly marked pick-up points or pad-eyes. For complex lifting requirements, provide lifting diagrams on the design drawings.

6-3 GEOMETRY.

The shape and size of fabricated camels are governed by the ship's geometry at waterline.

6-3.1 Length and Width.

Provide adequate length of camels in order to keep the contact pressure between camel and hull and between camel and pier fenders within allowable limits. This is particularly important where compressible fender faces are used that transfer reaction pressure directly to the hull plate versus the frames of the vessel. The length should not be less than the distance between three frames of the ship, three fenders or fender piles on the pier, or 30 feet (9.1 m), whichever is greatest. Minimum camel width is determined by the ship's required standoff; ships roll characteristics and freeboard, the presence of any overhanging projections on a ship and vertical obstructions on the dock such as gantry cranes or light poles.

6-3.2 Depth.

Provide adequate depth for submarine camels and separators to maintain contact with ship and pier/wharf in the full tidal range.

6-4 STABILITY.

There is usually some eccentricity between the horizontal load applied on the ship-side and the horizontal reaction provided on the dock-side. This is due to tilting of the camels (from imperfect flotation, buoyancy tank taking on water, etc.) and tendency of the camel to ride up and down with the vessel due to tidal fluctuations. The camel should have sufficient width, depth, and weight to provide roll stability for counteracting the effect of the load eccentricity and should have means of adjusting for variations in tilt and trim.

6-5 LOCATION.

For fine-lined ships, camels should generally be placed within quarter points of the ship to give strength and to bear on a reasonably straight portion of the hull. For straight-sided ships, camels may be located beyond the quarter points. Provide at least two camels for each class of ship. Camels should not be placed so as to bear directly against structural piles.

6-6 MISCELLANEOUS CONSIDERATIONS.

6-6.1 Protection.

Consider outfitting steel camels with a suitable protective coating or a cathodic protection system, depending on relative costs.

6-6.2 Buoyancy Tanks.

Buoyancy tanks should be compartmented or foam filled. Provide drainage plugs used for pressure testing the buoyancy tanks. Where pontoon camels are assembled in a single line, they should be ballasted for stability through plugged openings provided for this purpose. Consider the buoyancy of framing members and the weight of paint, if any, in the buoyancy and stability computations. Where buoyancy tanks are not foam filled to allow filling with ballast water or weights to adjust trim and freeboard of the camel, provide easily accessible fill/pump out and vent connections. These connections can be used to pump out excess water that leaks into the tanks.

6-6.3 Abrasion.

Camel fenders rubbing against a hull remove its paint. Exposed surfaces are subject to corrosive action, especially at the waterline. For these reasons, it is desirable to have camel fenders rub against hulls above the waterline where the hull can be repainted if necessary.

6-6.4 Service Life.

Service life is an important consideration related to camel selection operation and maintenance. Frequency of inspection, maintenance and overhaul should be determined for the type of camel system used. Life cycle economics should be considered in lieu of just first cost.

6-7 STANDARD CAMEL DESIGNS.

6-7.1 Submarine Camels.

Drawings and information on the camels described below may be obtained from the NAVFAC Atlantic - Engineering Criteria & Programs office.

6-7.1.1 Tapered Submarine Mooring Camel.

(NAVFAC Dwg 1404664-1404666). This tapered camel is framed from steel pipe with timber members on the front of the camel to support the rubber fender elements. This camel is intended for use with the SSN 688 class submarine.

6-7.1.2 Non-Tapered Submarine Mooring Camel.

(NAVFAC Dwg 1404943-1404947). This is a non-tapered version of the camel described above.

6-7.1.3 Attack Submarine Camel.

(NAVFAC Dwg 1404667-1404670). This camel is intended to replace the tapered camel described above. This camel is trapezoidal in shape and is framed from steel

pipe. This camel is intended for use with both the SSN 688 and SSN 21 class submarines.

6-7.1.4 Revised Attack Submarine Camel.

(NAVFAC Dwg 10400031-10400034). This camel reflects recent revisions made to the attack submarine camel described above.

6-7.1.5 Trident Submarine Camels.

Specifically designed camels using guide piles along the specific wharves are used for trident submarine homeports at both Kings Bay, Georgia and Bangor, Washington.

6-7.1.6 Composite Camels.

Universal composite submarine camels have been designed and placed in use at numerous submarine bases. These camels were designed to be used with any class of submarine in the U.S. Navy. As a NAVFAC standard design, both drawings and specifications are readily available for use in procurements. Design criteria is provided on the drawings. NAVFAC drawings 14019607-14019615 are available at: <http://www.wbdg.org/ffc/navy-navfac/cad>. The Universal Composite Submarine Camel was designed with the flexibility to not interfere with the Wide Aperture Array (WAA) and can therefore be located along the length of the submarine with maximum flexibility. However, special attention may be required for submarines equipped with the Conformal Acoustic Velocity Sonar (CAVES). This system may require the camels to be located in specific locations. Develop berth specific camel mooring plans and coordinate with SUBFOR.

6-7.2 Aircraft Carrier Camels.

6-7.2.1 Steel Pontoon CVN Camels.

Aircraft carrier camels designed specifically for CVN 68 class aircraft carriers were available through an indefinite quantity contract (N00189-00-D-0254) which expired in September 2005. Camel design is proprietary. On 2 September 2004 an exercise was conducted in berthing CVN 65 alongside Pier 6 South at Naval Station Norfolk. This was to learn more about CVN berthing at a double deck pier. One significant finding was the need to increase the standoff of the aircraft camel by approximately 5 feet (1.5 m) to give additional standoff. Figure 6-3 shows a CVN camel in plain view (prior to the additional 5-foot (1.5-m) standoff).

The following pertinent information is provided for the CVN camels:

- Construction – steel floating frame pontoon.
- Loads – 1500 kip (6672 kN) lateral and 500 kip (2224 kN) longitudinal reaction force transmitted to the camel fender system along the length of the camel. Values were based on maximum wind and current forces associated

with heavy weather conditions (95 mph (42.5 m/s) wind, 1 knot (0.51 m/s) current) and breasting reaction associated with CVN berthing assuming a maximum approach velocity of 0.5 feet/second (0.15 m/s).

- Suitable for placement along the flat side of the hull approximately between frames 110 and 190 with an allowable hull pressure of 30 psi (207 kPa).
- Working surface designed for 100 psf (4.8 kPa).
- Size: 56 feet-2 1/4 inch (17.1 m) wide with standoff of 57 feet-11 1/8 inch (17.7 m) (undeflected fender).
- Weight: 95.4 long tons (951 kN).
- Light draft: 3.66 feet (1.12 m); Live load draft: 4.34 feet (1.32 m).
- Light freeboard: 3.3 feet (1 m); Live load freeboard: 2.4 feet (0.73 m).

Figure 6-3 Aircraft Carrier Camel

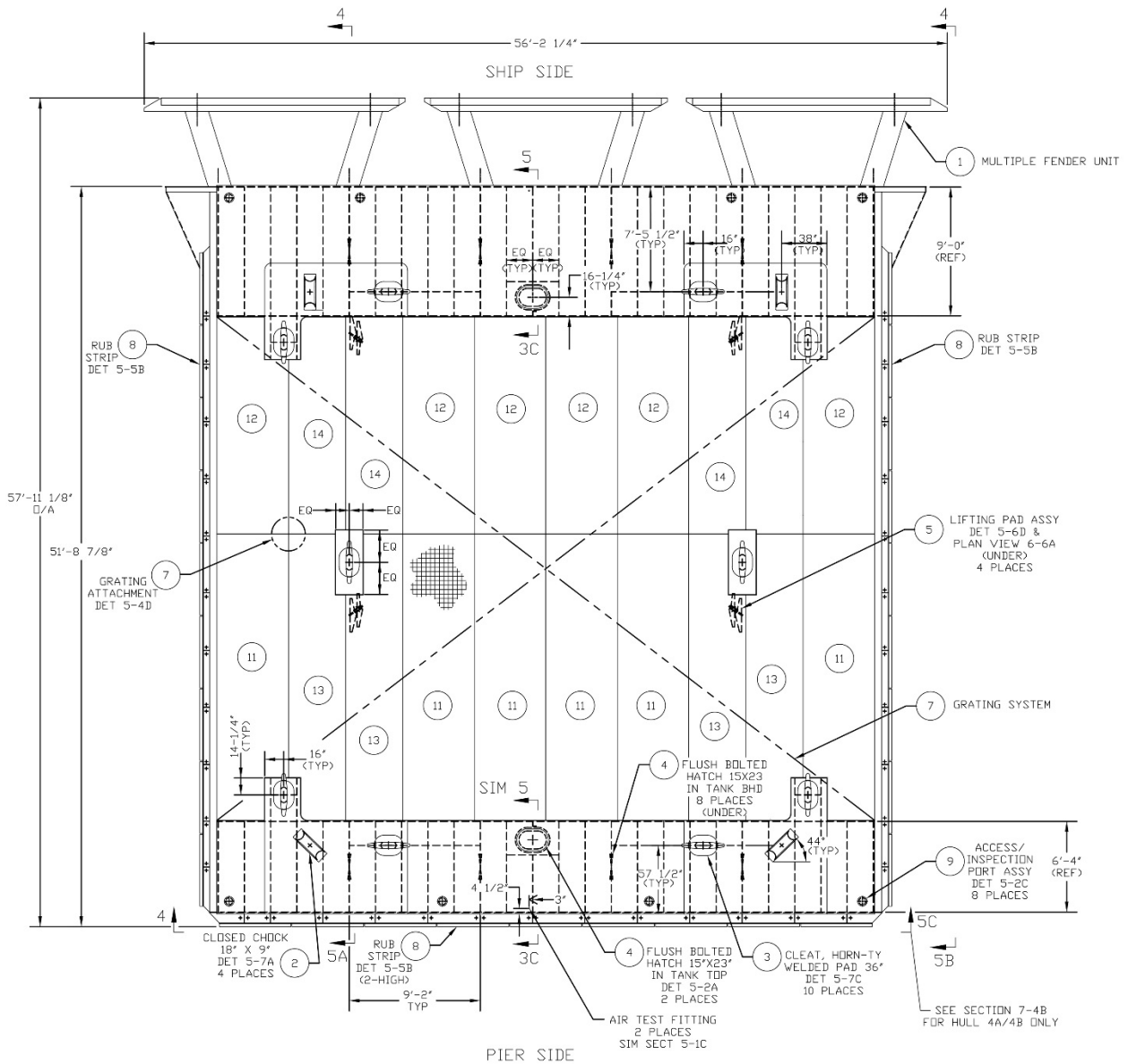

6-7.2.2 Universal Composite CVN Camel.

Under a design-build procurement, NAVFAC has developed a universal composite CVN camel. Universal composite CVN camel rendering is shown in Figure 6-4.

Universal composite CVN camel was developed based upon the following criteria:

- Construction – FRP.
- Loads – 1,500 kip (6,672 kN) lateral and 300 kip (1334 kN) longitudinal reaction force transmitted to the camel fender system along the length of the camel. Values were based on maximum wind and current forces associated with heavy weather conditions (95 mph (42.5 m/s) wind, 30 second gust, 1 knot (0.51 m/s) current) and breasting reaction associated with CVN berthing assuming a maximum approach velocity of 0.3 feet/second (0.09 m/s).
- Suitable for placement along the flat side of the hull approximately between frames 110 and 190 with an allowable hull pressure of 30 psi (207 kPa).
- Uniform live load on overall camel structure ~ 20 psf (1 kPa).
- Uniform live load on individual module top panel ~ 60 psf (3.9 kPa).
- Maximum vertical live load on top panel ~ 20 kips (89 kN) on 6 inch by 6 inch (152 mm by 152 mm) base plate.
- Size: 56 feet (17.1 m) wide with standoff of 63 feet-5 inch (19.3 m) (undeflected fender).
- Weight: 369.1 kips (1642 kN).
- Camel Height: 7 feet-8 inches (2.3 m).

6-8 SEPARATORS.

As mentioned previously, separators are a NAVSEA responsibility. Design for a universal submarine-to-submarine type separator is found on NAVSEA Dwg 6983485. A useful reference from NAVSEA is NSTM 018, Chapter 611, *Fenders and Separators*.

Figure 6-4 Universal Composite CVN Camel

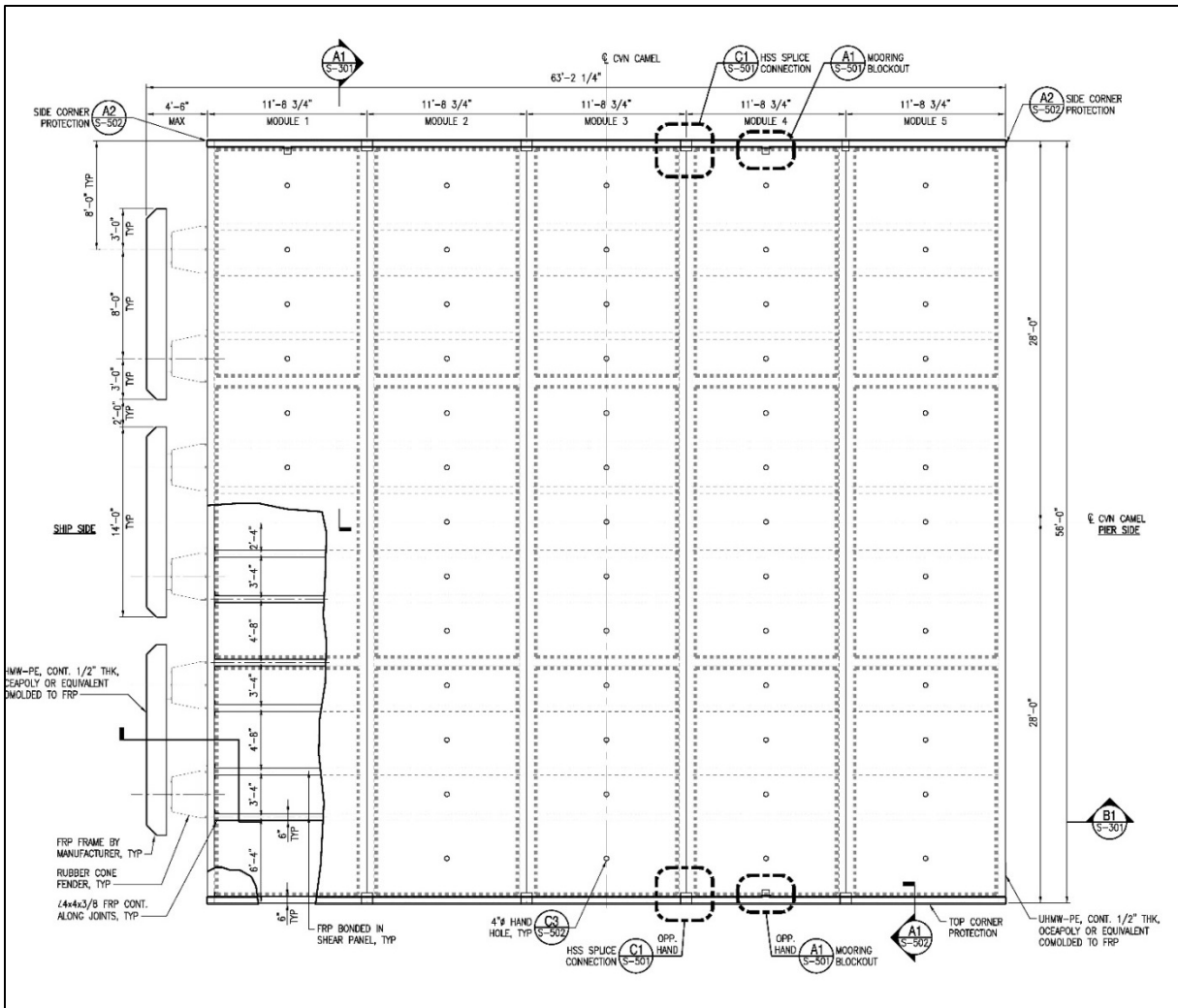

This Page Intentionally Left Blank

CHAPTER 7 ACCESS

7-1 GENERAL.

Several access structures are used in piers and wharves for moving personnel and cargo, and accommodating selected utility lines. They have unique design requirements. Some are of standard design while others are designed and constructed specifically to go with the facility. The access facilities covered by this manual are landing float, brow or gangway, brow platform, walkway or catwalk, and ramp. Utility booms are discussed in UFC 4-150-02, *Dockside Utilities for Ship Service*. Where there is a potential need for access by a physically handicapped person, meet the applicable requirements of the *Americans with Disabilities Act Accessibility Guidelines* and the *Uniform Federal Accessibility Standards*, and when they differ, the one with the greatest accessibility requirement will govern.

7-2 SAFETY.

Safety on piers and in pier design is an important consideration. Consider operational uses and where possible provide safety precautions, protections and warnings to minimize the potential hazards. Double deck piers require additional safety considerations. Potential uses and needs for pier deck space are unlimited and should be evaluated based on the local requirements. It is essential that safety and operators be involved in the pier design, so potential uses can be identified, categorized and policy determined. In particular high-voltage electrical, fall hazards, trip hazards, and access to industrial or mechanical areas are issues that require additional consideration. In light of this, a study was conducted entitled, *Lower Deck Pier Safety Study*. Numerous activities were examined in detail and a matrix developed specifying essential use activities as well as prohibited activities. Although this study was somewhat site specific for Naval Station Norfolk, it should be consulted for details on safety solutions and recommendations. For example, the study provides useful information such as details on all signage required and detailed plan views of both upper and lower decks for the double deck piers at Naval Station Norfolk which show:

- Utility locations
- Activity areas
- Striping
- Transit paths
- Vehicle turn locations
- Curb, fencing, guardrail, handrail, lighting, life ring, fall protection and signage locations

7-2.1 Fall Protection.

In contrast to previous versions of this document, fall protection is now a requirement for mitigating fall hazards on U.S. Navy piers and wharves. Comply with Department of the

Navy Fall Protection Guide, Section 9.13 Work Over Water. This reference provides the relevant information on standards, regulations, criteria, and requirements for fall protections. In particular, fall protection systems, criteria, and design requirements are provided.

7-3 LANDING FLOAT.

When piers and wharves need to be accessed from the waterside by small craft such as patrol boats (which cannot berth directly), a landing float and a brow are required.

7-3.1 Materials.

Flotation units may consist of foams of polystyrene and polyurethane, fiberglass-reinforced polyester resin shells with or without foam cores, metal pontoons, metal pipes, metal drums, and hollow concrete sections. Timber logs, the earliest form of flotation unit and the cheapest, have a tendency to become waterlogged and their use is not recommended. Decks of floats are variously made out of wood planks, plywood, plywood and fiberglass-resin coatings, concrete, and nonskid metal surfaces. Framework for floats is generally of preservative-treated timber, although steel and aluminum are often used. All ferrous metal hardware should be galvanized or otherwise protected from corrosion.

7-3.2 Mooring Systems.

Anchor floats to prevent movement by wind, current, waves and impact from the ships. Anchorage may consist of individual vertical (guide) piles, frames of batter and vertical piles, and cables or chains. When piles are used to anchor small floats, guides are furnished to secure the float to the anchor pile. Commonly used guides are rigidly braced metal hoops of pipes, rollers, or traveler irons. Chains and flat bar guides should not be used as they cause the float to hang up on the piles. See Figure 7-1 for details. This system works well for shallow waters with a large tidal range. In deeper water, the pile head may have to be supported by the structure or pile driven deeper. Anchorage may also be obtained from a cable or chain system attached to the ocean bottom or to the fixed pier or wharf structure.

7-3.3 Live Loads.

Design stages for landing personnel only for a uniform live load of 50 psf (2.4 kPa) or a concentrated live load of 500 pounds (2.2 kN) placed at any point on the deck surface. The float should not tilt more than 6 degrees from the horizontal when applying the concentrated live load of 500 pounds (2.2 kN).

Figure 7-1 Small Floating Stage

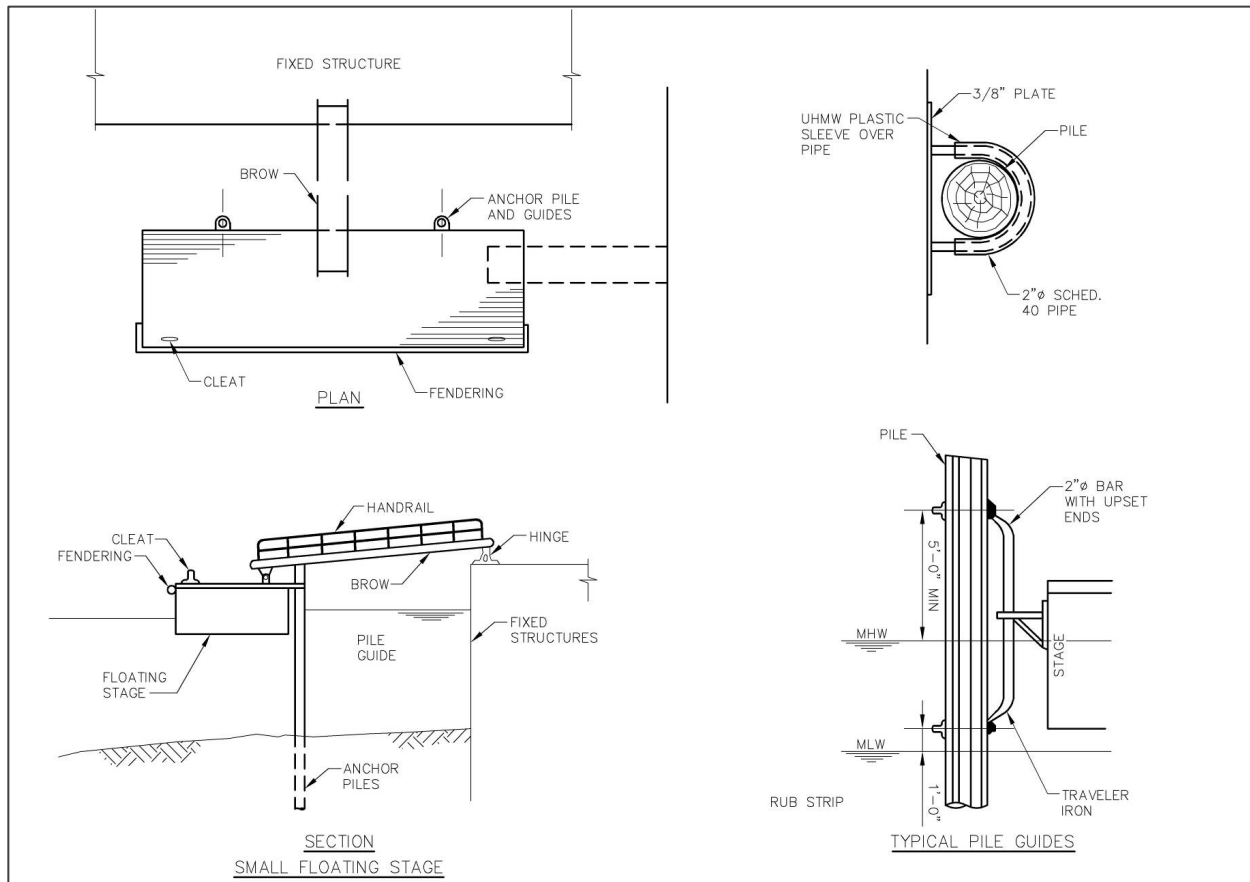

7-3.4 Freeboard.

Floating stages for small craft usually ride with the deck from 15 to 20 inches (381 to 508 mm) above the water surface under dead load. Live loads usually lower the float about 8 to 10 inches (203 to 254 mm).

7-3.5 Fendering.

Provide fenders on all floating stages. For small craft berthing, fenders may consist of soft, flexible rubbing strips (rubber tires, sections of hose).

7-3.6 Fittings.

Provide a minimum of three cleats (5,000-pound (22 kN) capacity) for securing small craft.

7-3.7 Finish.

Provide the deck with a nonskid surface. Where wheels or rollers from a brow will be resting on the float, provide guide channels or a skid plate to prevent damage to the float.

7-3.8 Concrete Float Elements.

Concrete encased plastic foam elements designed for use in concrete floating docks for marinas can be connected together in various configurations to be used as work floats. The mass added by the concrete encasement creates a very durable float that is less affected by waves and live loads than more lightweight systems.

7-4 BROW OR GANGWAY.

Brows are used for access to landing floats from the pier or wharf structure, however they are more frequently used to provide personnel access from a pier or wharf to a berthed ship.

7-4.1 Length.

Brows should be of sufficient length so that the slope will not exceed 1.5 horizontal to 1.0 vertical at the worst condition.

7-4.2 Widths.

Widths should be 36 inch (0.9 m) minimum (clear) passage for one-way traffic and 48 inch (1.2 m) minimum (clear) passage for two-way traffic. Provide a 60 inch (1.5 m) minimum (clear) passage for two-way traffic when personnel carry small loads.

7-4.3 Construction.

Use fiberglass, aluminum, steel, timber, or a combination of these materials. Aluminum and fiberglass are generally preferred for the low weight to strength ratio and corrosion protection.

7-4.4 Live Load.

Design the brow structure for a uniform live load of 75 psf (3.6 kPa) and a concentrated live load of 200 pounds (0.9 kN) applied anywhere. A reduction in the live load to 50 psf (2.4 kPa) may be permissible where the brow is to be used in conjunction with a landing float. For calculation of reaction to the landing float, the live load can further be reduced to 25 psf (1.2 kPa).

7-4.5 Handrails.

Design handrails to resist 50 plf (0.73 kN/m), applied in any direction at the top. Design handrails to resist a single concentrated load of 200 pounds (0.9 kN), applied at any

direction at any point along the top. It is assumed that the uniform load and the concentrated load do not act concurrently. The handrail may be designed to serve as the top chord of a truss when sufficiently braced.

7-4.6 Safety.

Provide safety devices to keep the brow from rolling off the platform deck and to prevent movement of the platform while in use. Clip safety chains into position for personnel safety. Large tidal variations are a problem because these may cause the brow to roll off the platform. A similar situation exists when high winds, currents, and extreme tides pull a ship away from the pier. Numerous accidents have been associated with brows being supported by pallets either on the ship end or pier end of the brow. Brows are not to be used in conjunction with pallets. If a platform is necessary, properly engineer, design, and build under the technical cognizance of NAVFAC. NAVFAC EXWC had designed a safety gangway ramp as step to alleviate this issue. For additional information, contact NAVFAC Atlantic - Engineering Criteria & Programs.

7-5 BROW PLATFORMS.

Brow platforms are used when a brow from ship deck to pier deck is not practical, or presents an obstruction. Examples are portal crane trackage along repair berths, large tidal variations, and great height from deck to pier. Aircraft carriers (CVNs) usually use one brow forward and two aft. These brows require platforms 20 feet (6.1 m) or higher. This platform is basically a truncated tower, with typical measurements of 12 by 12 feet (3.7 by 3.7 m) at the base, while the top deck is 5 feet (1.5 m) wide and 10 feet (3 m) long. If small stair platforms are built alternately opposite hand, the requirement for a large platform can be met by lashing two of the smaller ones together. Sometimes the ship end of the brow can be connected to a rotatable platform which is permanently fixed to the ship by means of pins that lock the brow pivot hooks to the circular rotating portion of the rotatable platform. Construction materials and live load requirements are the same as for brows.

7-6 BROW AND PLATFORM DESIGNS.

Standard designs for brows and platforms are found in NAVFAC Dwg SD1405000-1405041 at: <http://www.wbdg.org/ffc/navy-navfac/cad>.

7-7 WALKWAY OR CATWALK.

These are permanent personnel access bridges installed between shore and different elements of piers and wharves. One example is a walkway between the pier or wharf structure and a mooring dolphin located some distance away as shown in Figure 2-1.

7-7.1 Width.

For walkways between shore and a U-shaped wharf, a 4-foot (1.2 m) width is recommended. For infrequently used walkways, the minimum width should be 3 feet (0.9 m).

7-7.2 Live Load.

Design all walkway structures for 100 psf (4.8 kPa) live load.

7-7.3 Construction.

Walkway decking should be slip-resistant aluminum or fiberglass grating. Framing may be wood, aluminum, or fiberglass members. In view of the light loads encountered, piles supporting deck stringers can be of treated timber. Where loads and installation difficulty make timber piles inadequate, concrete and steel piles may be used.

7-7.4 Handrails.

Provide handrails on either side of the walkway. Consider handrails for use along edges of approach trestles and along non-berthing extents of docks or wharves.

7-8 RAMPS.

Transfer bridges or ramps are sometimes required for moving vehicles or heavy cargo from ships, similar to a roll-on/roll-off (RO/RO) operation. MSC RO/RO ships do not require any special features on existing piers. Sideport ramps are stowed and handled by the ship. Sternport ramps are hinged to the vessel and extend to dockside or floating equipment (lighters, causeways, stages). These ships also have conventional cargo gear.

The LHA-class of amphibious assault ships has vertical lift stern gates, possess RO/RO capability. Installations accommodating vessels of this type should consider the use of a ramp or transfer bridge, as shown on Figure 7-2, to minimize the time required for movement of vehicular equipment and for loading of supplies. Design and construction of ramps should be similar to highway bridges. One key issue regarding ramps is clearance from pier/wharf edge obstructions, i.e. utility risers, cleats, bollards, etc. When designing piers and wharves, consider the specific location for ramp landing as well as structural deck strength.

As discussed previously, sideport loading ramp access for LHA, LHD, and LPD 17 class ships is an important consideration, particularly on double deck piers.

Figure 7-2 Transfer Bridge for LHAs

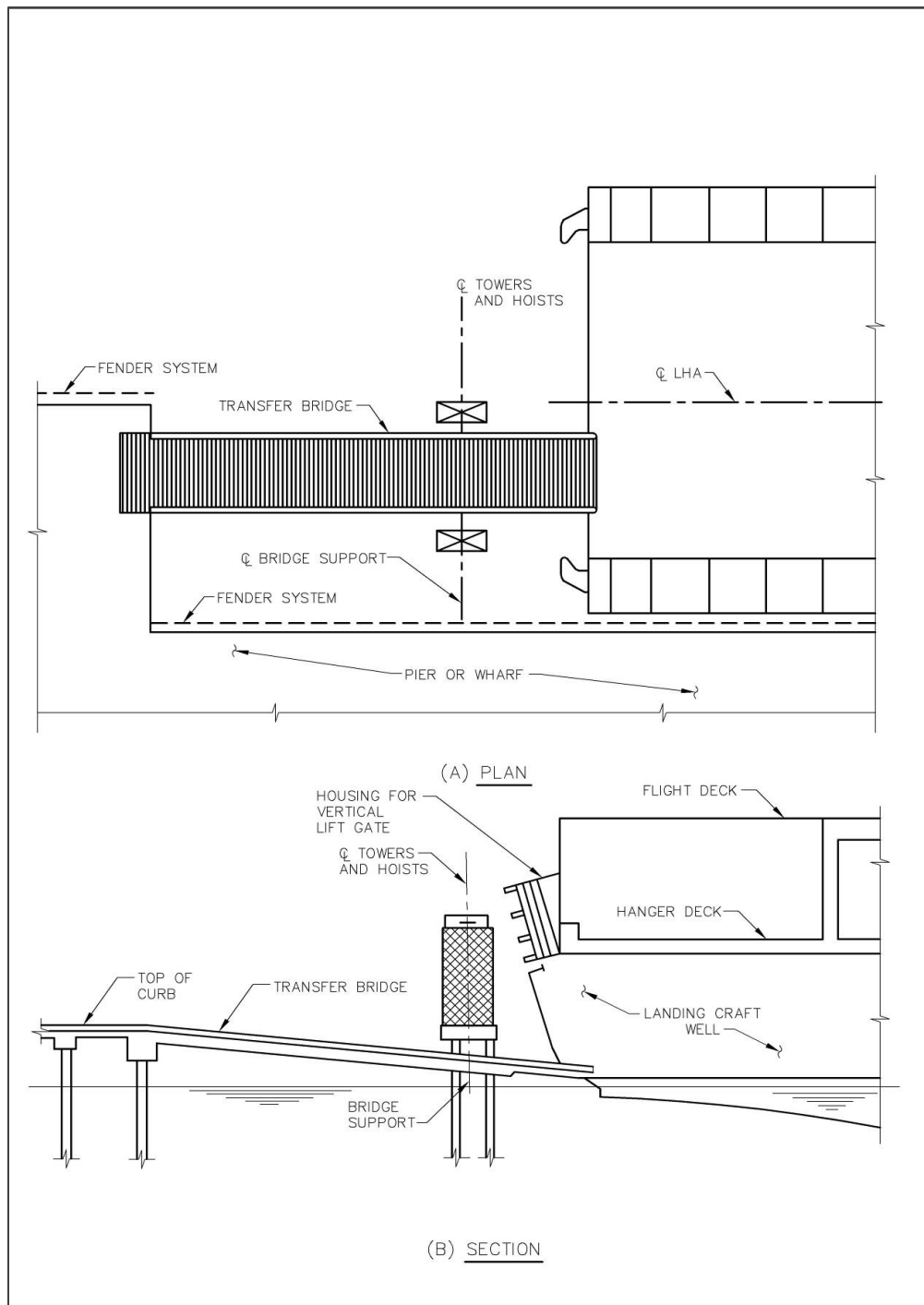

7-9 SAFETY LADDERS AND LIFE RINGS.

7-9.1 Safety Ladders.

Provide safety ladders from pier or wharf deck to water at a maximum spacing of 400 feet (122 m) or as noted below with regard to life rings. Such ladders should be at least 1 foot-4 inches (0.41 m) wide and should reach the lowest water elevation anticipated. Safety cages are not required. Safety ladders may have grab bars to protect from mooring lines and hinges to protect the ladder from small boat damage in lieu of rail extensions. It is recommended to provide guard timbers/fenders on either side of the ladder, or to protect within the fender system. Locate the ladders on either side for a pier wider than 50 feet (15.2 m). For piers less than 50 feet (15.2 m) wide, insure that an individual could swim under the pier to reach the ladder on the opposite side or provide ladders on both sides. Locate ladders on the waterside for a wharf at places convenient to anyone who might accidentally fall into the water. Figure 7-3 illustrates a safety ladder for a pier or wharf, while Figure 7-4 illustrates a safety ladder with a 3-foot (0.9 m) extension along an unprotected bulkhead, rope guards may be required to protect the ladder extension.

Safety/emergency egress ladders are different than access ladders. Safety regulations may vary from location to location. Coordinate with local safety office on specific ladder requirements, marking, and use.

7-9.2 Life Rings.

29 CFR 1917.26, *First Aid and Lifesaving Facilities* requires that a U.S. Coast Guard approved 30-inch (0.76 m) life ring, with at least 90 feet (27 m) of line attached, shall be available at readily accessible points at each waterside work area where the employees' work exposes them to the hazard of drowning. Provide a readily available portable or permanent emergency egress ladder giving access to the water within 200 feet (61 m) of work areas. Co-locate life rings with permanent ladders.

Figure 7-3 Safety Ladder at Protected Berth

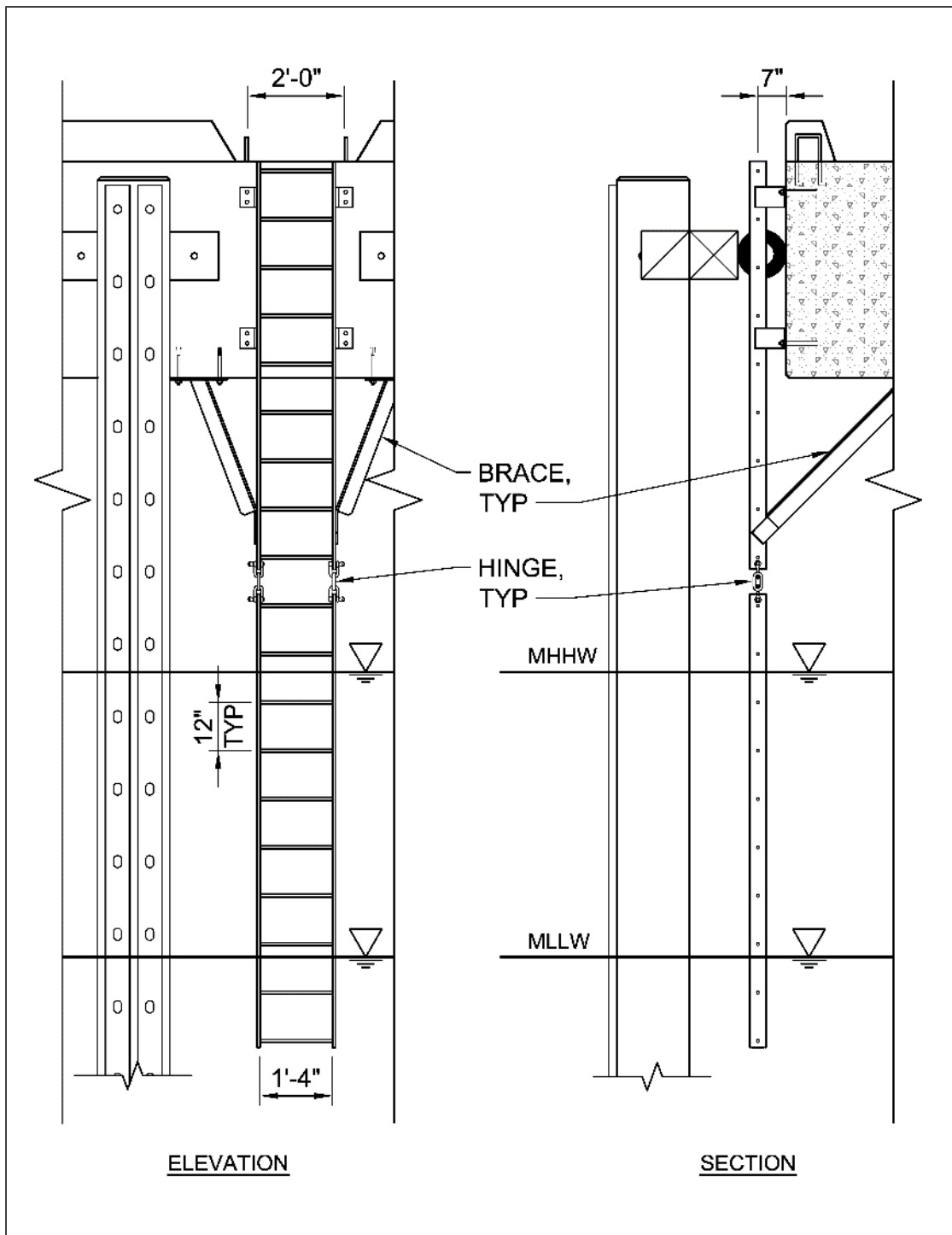
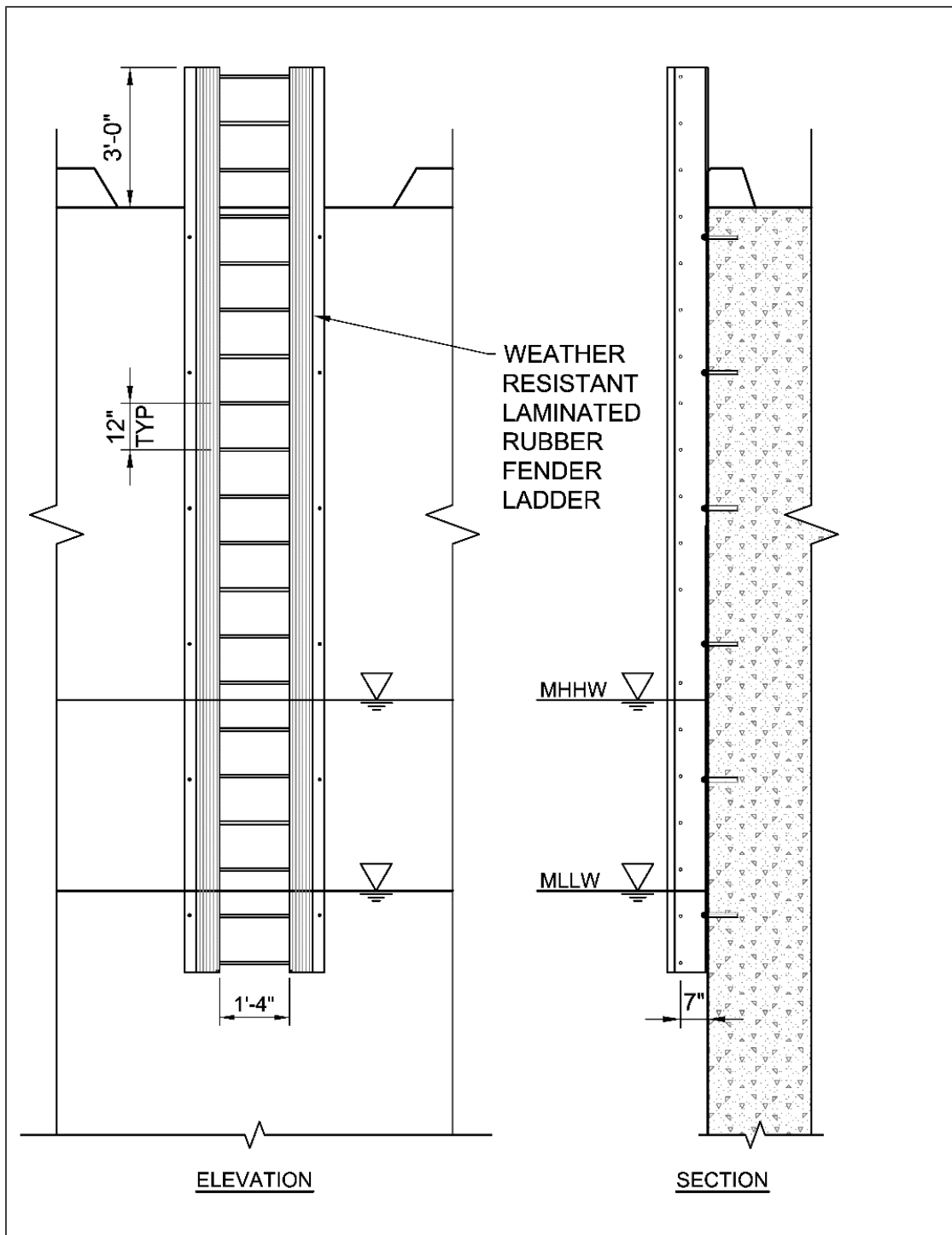

Figure 7-4 Safety Ladder at Unprotected Berth



APPENDIX A REFERENCES

A-1 GOVERNMENT PUBLICATIONS.

FEDERAL EMERGENCY MANAGEMENT AGENCY (FEMA)

<https://www.fema.gov/media-library/assets/documents/757>

FEMA 356, *Prestandard and Commentary for the Seismic Rehabilitation of Buildings*

NAVAL FACILITIES ENGINEERING COMMAND, ATLANTIC

NAVFAC Atlantic, *Amphibious Warfare Ship to Pier Interface Study*, February 10, 2004

NAVFAC, TranSystems Corporation, American Bridge Company, University of Maryland and Lewis Zimmerman & Associates, Inc. *Lower Deck Pier Safety Study*, March 2004.

NAVAL FACILITIES ENGINEERING AND EXPEDITIONARY WARFARE CENTER (NAVFAC EXWC), 1100 23RD AVENUE, PORT HUENEME, CA 93043

http://www.navfac.navy.mil/navfac_worldwide/specialty_centers/exwc.html
(password required)

Rocker, Karl, *Handbook for Marine Geotechnical Engineering*, March 1985

Gaughen, Dave; Pendleton, David and Zarate, Daniel. Naval Facilities Engineering Services Center, ESTCP Project WP-200528, *Zero VOC, Coal Tar Free Splash Zone Coating*, December 2010.

CR-NAVFAC-EXWC-CIOFP-1316, Oct. 2013, *USS Gerald R. Ford (CVN-78) Operational In-Port Analysis including Berthing, Mooring and Officers Brow Placement*

NCEL CR 89.005, *Prestressed Concrete Fender Piles: Fender System Designs*

NCEL R-927, *Laterally Loaded Partially Prestressed Concrete Piles*

NCEL R-935, *Lateral Load Distribution on One-Way Flat Slab; Influence Surfaces for Elastic Plates*

NCEL TM-5, *Advanced Pier Concepts, Users Data Package*

NCEL TM 53-89-03, *Prestressed Concrete Fender Piling User Data Package*

NCEL TR-939, *The Seismic Design of Waterfront Retaining Structures*, Ebeling & Morrison, 1992

NCEL UG-0007, *Advance Pier Concepts User's Guide*

SP-2005-SHR, *Limited Flexural Tests of Plastic Composite Pile Configurations*

SP-2045-SHR, *Proposed Design Criteria for Chocks and Wales*

TM-2158-SHR, *Study of Recycled Plastic Fender Piles*

TR-2077, *Seismic Design for Soil Liquefaction*, June 1997

TR-6014-OCN, *Mooring Design Physical and Empirical Data*

TR-6015-OCN, *Foam Filled Fender Design to Prevent Hull Damage*

TR-6064-OCN, *Berthing Guidelines for Submarines*

TR-6074-OCN, *Added Mass for Berthing U.S. Navy Vessels*

TR-NAVFAC-EXWC-CI-1304, *Enhanced Guidelines for Marine Concrete Repair*

TR-NAVFAC-EXWC-CI-1413, *The Use of Prestressed Concrete for Corrosion Prevention in US Navy Piers*

NAVAL SEA SYSTEMS COMMAND, WASHINGTON, DC

<http://doni.daps.dla.mil/> (password required)

NAVSEA OP-5, Vol. 1, *Ammunition And Explosives Safety Ashore Naval Ships Technical Manual*, February 2013

NSTM 018, Chapter 611, *Fenders and Separators*

NAVSEA 8010, S0570-AC-CCM-010/8010, *Industrial Ship Safety Manual for Fire Prevention and Response*

NAVY CRANE CENTER

http://www.navfac.navy.mil/navfac_worldwide/specialty_centers/ncc.html

Navy Crane Center Instruction 11450.2, *Design of Navy Shore Weight Handling Equipment*, dated March 18, 2013

UNIFIED FACILITIES CRITERIA (UFC)

<https://www.wbdg.org/ffc/dod/unified-facilities-criteria-ufc>

MIL-STD-3007, *Standard Practice for Unified Facilities Criteria*

UFC 1-200-01, *DoD Building Code (General Building Requirements)*

UFC 3-220-01, *Geotechnical Engineering*

UFC 3-301-01, *Structural Engineering*

UFC 3-530-01, *Interior and Exterior Lighting Systems and Controls*

UFC 3-570-01, *Cathodic Protection*

UFC 4-025-01, *Security Engineering: Waterfront Security*

UFC 4-150-02, *Dockside Utilities for Ship Service*

UFC 4-150-06, *Military Harbors and Coastal Facilities*

UFC 4-150-08, *Inspection of Mooring Hardware*

UFC 4-152-07, *Small Craft Berthing Facilities*

UFC 4-159-03, *Moorings*

UFC 4-213-12, *Dry Docking Facilities Characteristics*

UFC 4-860-03, *Railroad Track Maintenance and Safety Standards*

UNIFIED FACILITIES GUIDE SPECIFICATIONS (UFGS)

<https://www.wbdg.org/ffc/dod/unified-facilities-guide-specifications-ufgs>

UFGS 03 31 29, *Marine Concrete*

UFGS 35 59 13.16, *Marine Fenders*

UNITED STATES ACCESS BOARD

<https://www.access-board.gov/attachments/article/1029/ABAstandards.pdf>

Architectural Barriers Act Standards

UNITED STATES ARMY CORPS OF ENGINEERS

<http://www.publications.usace.army.mil/USACEPublications/EngineerManuals.aspx>

USACE EM 1110-2-2503, *Engineering and Design: Design of Sheetpile Cellular Structures, Cofferdams, and Retaining Structures*

UNITED STATES DEPARTMENT OF DEFENSE

<https://www.access-board.gov/guidelines-and-standards/buildings-and-sites/about-the-aba-standards/background/dod-memorandum>

Deputy Secretary of Defense Memorandum for Secretaries of the Military Departments,
Chairman of the Joint Chiefs of Staff, Undersecretaries of Defense, Assistant
Secretaries of Defense...Subject: *Access for People with Disabilities* October 31,
2008

**UNITED STATES DEPARTMENT OF LABOR, OCCUPATIONAL HEALTH AND
SAFETY ADMINISTRATION**

https://www.osha.gov/pls/oshaweb/owastand.display_standard_group?p_toc_level=1&p_part_number=1917

29 CFR 1917.26, *First Aid and Lifesaving Facilities*

UNITED STATES NAVY

http://www.public.navy.mil/navsafecen/Documents/OSH/FP/FALL_PROTECTION_GUIDE_MAY_15.pdf

DON Fall Protection Guide, May 2015

MIL-STD 1625D (SH) Safety Certification Program for Dry docking Facilities and
Shipbuilding Ways for U.S. Navy Ships

U.S. NAVY, OFFICE OF THE CHIEF OF NAVAL OPERATIONS

<http://doni.daps.dla.mil/> (password required)

OPNAVINST 3040.5D, *Procedures and Operations Reporting Requirements for Nuclear
Reactor and Radiological Accidents*

OPNAVINST 4700.7L, *Maintenance Policy for U.S. Navy Ships*

A-2 NON-GOVERNMENT PUBLICATIONS.

**AMERICAN ASSOCIATION OF STATE HIGHWAY AND TRANSPORTATION
OFFICIALS (AASHTO)**

<http://www.aashto.org>

AASHTO Standard Specifications for Highway Bridges, 17th Edition

AASHTO Bridge Guide and Manual Interim Specification

AASHTO Dynamic Ice Forces on Piers and Piles

AASHTO Guide Specifications for Bridge Railings

AASHTO Ice Pressure on Engineering Structures

AMERICAN CONCRETE INSTITUTE (ACI)

<https://www.concrete.org/>

ACI 209.2R 08, *Guide for Modeling and Calculating Shrinkage and Creep in Hardened Concrete*

AMERICAN RAILWAY ENGINEERING AND MAINTENANCE-OF-WAY ASSOCIATION (AREMA)

<https://www.arema.org/publications/mre/index.aspx>

American Railway Engineering Association *Manual for Railway Engineering*

AMERICAN SOCIETY OF CIVIL ENGINEERS (ASCE)

<http://www.asce.org/publications/>

ASCE/COPRI 61-14, *Seismic Design of Piers & Wharves*

ASCE 7-10, *Minimum Design Loads for Buildings and Other Structures*

AMERICAN WOOD PROTECTION ASSOCIATION (AWPA)

<http://www.awpa.com/>

AWPA E5-15, *Standard Test Method for Evaluation of Wood Preservatives to be Used in Marine Applications (UC5A, UC5B, UC5C); Panel and Block Tests*

CANADIAN STANDARDS ASSOCIATION (CSA)

<http://www.goodfellowinc.com/wp-content/uploads/2013/06/CSA-S6-6-+-S6S1-10-PARTIE-1.pdf>

CAN/CSA-S6, *Canadian Highway Bridge Design Code*

INTERNATIONAL CODE COUNCIL (ICC)

<http://www.iccsafe.org>

ICC/ANSI A117.1, *Accessible and Usable Buildings and Facilities*

2015 International Building Code

**PERMANENT INTERNATIONAL ASSOCIATION OF NAVIGATION CONGRESSES
(PIANC)**

<http://www.pianc.us/>

Guidelines for the Design of Fender Systems, 2002

PRECAST / PRESTRESSED CONCRETE INSTITUTE (PCI)

<http://www.pci.org>

PCI Design Handbook (section 7.3.1.1)

**TRANSPORTATION RESEARCH BOARD OF THE NATIONAL ACADEMIES
NATIONAL COOPERATIVE HIGHWAY RESEARCH PROGRAM (NCHRP)**

<http://www.trb.org/NCHRP/NCHRP.aspx>

NCHRP Report 611, Seismic Analysis and Design of Retaining Walls, Buried Structures, Slopes, and Embankments, 2008

A-3 AUTHORED PUBLICATIONS.

IDriss, I.m. and Youd, T.L. *Proceedings of the NCEER Workshop on Evaluation of Liquefaction Resistance of Soils*, NCEER-97-0022, December 1997.

Peterka, J.A. and Shahid, S. (1998) *Design Gust Windspeeds in the U.S.*, *Journal of Structural Engineering*, 124, 207-214

APPENDIX B GLOSSARY

B-1 DEFINITIONS.

Breasting Dolphin – A freestanding independent structure that a vessel will bear against when current, wind or berthing motion moves the ship into the pier or wharf. Breasting Dolphins are typically equipped with energy absorbing fender systems and are pile supported or solid fill structures.

Bulbous Bow – A protruding bulb at the bow (or front) of a ship just below the waterline.

Bullrail – A wide low curb along the outboard edge of the pier or wharf. The bullrail may be cast-in-place concrete, steel or timber. Bullrails may be fixed or removable. Mooring hardware is often mounted on top of the bullrail.

Camel – A floating structure used to separate a moored vessel from the pier or wharf. Camels are used with ships that have hull configurations that do not match well with typical pier or wharf fender systems, such as, submarines or where vessels require an offset from the pier or wharf due to deck or superstructure overhangs such as an aircraft carrier.

Catwalk – A narrow walkway, especially one high above the surrounding area, used to provide access or allow workers to stand or move.

Cold Iron – Used to describe the condition of a ship when all shipboard boilers, engines, and generators are inoperative during repairs or due to intentional shutdown and can furnish none of the ship's required services.

Degaussing – The degaussing system is installed aboard ship to reduce the ship's effect on the Earth's magnetic field. In order to accomplish this, the change in the Earth's field about the ship's hull is "canceled" by controlling the electric current flowing through degaussing coils wound in specific locations within the hull. This, in turn, reduces the possibility of detection by these magnetic sensitive ordnance or devices.

Dolphins – A free standing pile supported or solid filled structure used for mooring and berthing vessels, protection of the end of piers or wharves, turning ships, or protection of bridge substructure.

Dry docks – A specialized facility used for the repair of ships where the vessel is removed from the water or placed within a lock and the water is removed leaving the ship in the dry to facilitate repairs.

Fenders – Energy absorbing devices used on the face of a pier, wharf or dolphin to protect the ship and shore facility from damage due to contact between the two during berthing and mooring.

Hawser – A thick cable or rope used in mooring or towing a ship.

Homeport – Port for a specific ship that has been identified as such by Commander Fleet Forces Command and is listed in the Naval Register. The homeport is where the ship is assigned and offers all requisite services required by the ship to include the full complement of hotel services.

Hotel Services – Dockside utilities provided for a ship at a berth (also called ships services, utility services, and cold iron services).

Ligherage – Small craft designed to transport cargo or personnel from ship to shore. Ligherage includes amphibians, landing craft, discharge lighters, causeways, and barges. Based on the idea of using use hollow, sheet steel boxes as pontoons and pontoon-assembled structures.

Magnetic Treatment Facility – Due to magnetic fields that are constantly being encountered during normal ship operations, ships and submarines build up a magnetic signature. The earth's natural magnetic fields between the North and South poles are being crossed routinely while the vessels are underway. The traversing of these natural fields, and vessels lying dormant for extended periods of time during scheduled maintenance, result in changes to a vessel's magnetic signature. Correcting those changes requires a thorough treatment process to minimize the level of permanent magnetism. This occurs at Navy Magnetic Treatment Facilities, also known as deperming stations.

Monopile Dolphin – A single pile dolphin usually consisting of a large diameter concrete or steel pipe pile filled with concrete. Monopile dolphins can be used as mooring or breasting dolphins. When used as a breasting dolphin, the monopile dolphin is faced with fendering elements.

Mooring Dolphin – A freestanding pile supported or solid filled structure used for mooring vessels. Mooring dolphins are usually placed at the bow or stern of a moored ship to provide mooring points to attach breasting lines, bow lines and stern lines.

Nesting – Placing vessels alongside one another in a parallel configuration in which they are moored to one another.

Pier – A pier is a structure that projects out from the shore into the water. A pier is oriented either perpendicular to or at an angle with the shore. It may be used on both sides, although there are instances where only one side is used because of site conditions or because there is no need for additional berthing.

Port of Call – Any port where a ship stops along the way other than its homeport, or a stop at a fueling pier, an ammunition pier, a supply pier, or a repair pier. The only real requirements for a port of call would be that it has sufficient dredge depth and that it provides secure mooring. Ship does not go cold iron in port of call and uses its organic systems. However, local determinations and justifications can warrant adding specific features at ports of call. Many of the new classes of ships have concepts of operations and special mission requirements that have resulted in making accommodations at

ports in forward operating areas that ordinarily would not be required, i.e. hotel services. These are handled on a case by case basis and driven by operational requirements.

Roll on/Roll off – Also known as RORO. Provision on pier or wharf for vessels designed to carry wheeled cargo, such as cars, trucks, semi-trailer trucks, trailers, and railroad cars, that are driven on and off the ship on their own wheels or using a platform vehicle, such as a self-propelled modular transporter.

Scupper – An opening for the purpose of draining water.

Slip – The space between two approximately parallel piers or the space formed by a cut into the land that provides two approximately parallel mooring faces.

Sonar Dome – Located on the hulls of submarines and surface ships. Their purpose is to house electronic equipment used for detection, navigation, and ranging.

Sponson – A projection extending from the side of a vessel.

Weep Hole – A small opening in a wall which allows water to drain.

Wharf – A wharf is a structure oriented approximately parallel to the shore. Ships can only be moored at the offshore face of a marginal wharf. When water depths close to shore are not adequate to accommodate deep draft ships, the wharf, consisting of a platform on piles, is located offshore in deep water and is connected to shore along its length or at one or more points by pile-supported trestles, usually at right angles to the wharf.

B-2 ABBREVIATIONS.

AASHTO	American Association of State Highway and Transportation Officials
ACI	American Concrete Institute
AISC	American Institute of Steel Construction
ANSI	American National Standards Institute
AREMA	American Railway Engineering and Maintenance-of-Way Association
ASCE	American Society of Civil Engineers
ASD	Allowable Stress Design
ASTM	American Society of Testing and Materials
DoD	Department of Defense
ea	each
FEMA	Federal Emergency Management Agency
ft	feet
g	gravity
IBC	International Building Code
ICC	International Code Council
in	Inches
k	Kips (1,000 lbs)
kg	Kilogram
kg/m³	Kilograms per Cubic Meter
km/h	Kilometers per Hour
kN	Kilonewton
kN/m	Kilonewton per Meter
kN/m²	Kilonewton per Square Meter
kPa	Kilopascal

ksf	Kips per Square Foot
lbs	Pounds
lb/ft	Pounds per Foot
lb/ft²	Pounds per Square Foot
lb/ft³	Pounds per Cubic Foot
lb/in²	Pounds per Square Inch
LRFD	Load and Resistance Factor Design
m	Meter
m²	Square Meter
m/s	Meters per Second
mil	0.001 Inches
mm	Millimeter
mm²	Square Millimeter
MCE_R	Risk-Targeted Maximum Considered Earthquake
MPa	Megapascal
MPa/m	Megapascal per Meter
mph	Miles per Hour
MRI	Mean Recurrence Interval
NFPA	National Fire Protection Association
pci	Pounds per Cubic Inch
PGA	Maximum Considered Earthquake Geometric Mean (MCE _G) Peak Ground Acceleration
pcf	Pounds per Cubic Foot
plf	Pounds per Linear Foot
psf	Pounds per Square Foot
psi	Pounds per Square Inch

RCSC	Research Council on Structural Connections
S_s	Risk-Targeted Maximum Consider Earthquake (MCE _R) Ground Motion of 0.2-Second Spectral Response Acceleration
S₁	Risk-Targeted Maximum Considered Earthquake (MCE _R) Ground Motion of 1.0-Second Spectral Response Acceleration
S_{s,5/50}	Short-period (0.2-second) spectral response acceleration with a 5% probability of being exceeded in 50 years
S_{1,5/50}	Long-period (1.0-second) spectral response acceleration with a 5% probability of being exceeded in 50 years
S_{s,10/50}	Short-period (0.2-second) spectral response acceleration with a 10% probability of being exceeded in 50 years
S_{1,10/50}	Long-period (1.0-second) spectral response acceleration with a 10% probability of being exceeded in 50 years
S_{s,20/50}	Short-period (0.2-second) spectral response acceleration with a 20% probability of being exceeded in 50 years
S_{1,20/50}	Long-period (1.0-second) spectral response acceleration with a 20% probability of being exceeded in 50 years
UFC	Unified Facility Criteria
V	Velocity

APPENDIX C HIGH MAST LIGHTING

Please Post



Safety Alert

Pier high mast lighting structural failure

DESCRIPTION/BACKGROUND:

High mast lighting systems are used for lighting on piers and other structures. Design includes a ring assembly at the "mast" or pole top to support fixtures facilitating lowering of the ring by an internal cable pulley/motor system to access/replace lights or bulbs.

CONCERN: Mast lighting systems at Naval Station Norfolk have experienced an apparent defect where the latching mechanism fractures at the top of the mast light assembly prematurely. These fractured latching arms can then fray associated support cables which support the light ring. Once the support cables fray to a critical point, the entire light ring assembly can fall catastrophically - which has occurred. A subsequent investigation at Naval Station Norfolk pier high mast lighting has revealed additional lights of various designs similarly affected by latching mechanism fracture and cable fray. Many of the latching mechanisms inspected were reported to have a clearly improved design however, and did not exhibit signs of wear or failure.



INDIRECT CAUSE: The cable was incorrectly tightened causing retraction of the cable.

LESSONS LEARNED/RECOMMENDATION: Inspect high mast light systems for latching mechanism fracture/cracking. Visually inspect support cables for signs of wear and fray. While not involved in the failure, it is also recommended that the inspection include (1) a visual examination of the internal master cable for signs of wear as it retracts/coils and (2) a visual examination of the high mast pole splice for any signs of cracking, particularly for systems that have been in operation for a number of years. Any latching mechanism or cable failures noted during inspection should result in the light ring being lowered to ground until repairs can be made (or if pole splice cracking is observed the pole taken down). In some case it may be acceptable to provide temporary safety strapping between the light ring and mast pole with engineering consultation to facilitate continued light use until permanent repairs can be made.



RETROFIT: Where failures are discovered, repairs/retrofit of internal motor/cable assembly and top latching assembly can be performed. Contractor repairs are underway at Naval Station Norfolk. A manufacturer source experienced with retrofitting high mast lights is (www.eaglehighmast.com).





SAFETY ABSTRACT – HIGH MAST PIER LIGHTS



DESCRIPTION OF THE HAZARD:

- ◆ A high mast light support cable parted causing the light assembly to be partially suspended at the top of the pole which did not allow for the light to be lowered for maintenance. The plan was to use an aerial work platform and crane to lower the light for maintenance and inspection. The area immediately around the light structure was secured with caution tape and traffic cones. Before coordinated efforts could be made, the supporting mechanisms failed causing the lighting assembly to fall to the pier surface. There were no injuries or damage to property other than the light assembly.

SYSTEM INVOLVED:

- ◆ High mast lighting systems are used by the Navy to illuminate piers and other structures. They utilize a light ring assembly supported by a system of wire cables. This light ring is designed to be lowered to the ground mechanically via an internal pulley system so that maintenance can be performed from the ground level.

EVENT:

- ◆ The High Mast Light ring assembly fell at a NAVSTA Norfolk double deck pier causing catastrophic damage to the light ring assembly.

SAFETY CONCERN:

- ◆ Potential Life Safety Concern related to High Mast Lighting systems on Navy piers and elsewhere.
- ◆ Multiple designs at Naval Station Norfolk have been discovered to have a design defect where the latching mechanism fractures at the top of the mast light. These fractures can then cause fraying of the support cables which support the light ring. When the cables fray to a critical point, the light ring can fall catastrophically. Subsequent investigation has revealed additional lights of various designs similarly affected by latching mechanism fracture and cable fraying.

DIRECT CAUSE:

- ◆ Stress and fatigue caused the failure of the supporting cables and locking devices which caused the light assembly to fall.

INDIRECT CAUSE:

- ◆ Movement of the lighting assembly due to environmental conditions caused chaffing and wearing of the supporting system.

RECOMMENDATION:

- ◆ PWDs throughout NAVFAC inspect High Mast Lighting systems for fractures/cracking. Visually inspect support cables for signs of wear. The internal master cable should be inspected. Recommend that the high mast pole splice point be examined for signs of cracking, particularly for systems that have been in operation for several years. Any latching mechanism or cable failures noted should result in the light ring being lowered until repairs effected.