

UNIFIED FACILITIES CRITERIA (UFC)

CONCRETE FLOOR SLABS ON GRADE SUBJECTED TO HEAVY LOADS



APPROVED FOR PUBLIC RELEASE; DISTRIBUTION UNLIMITED

UNIFIED FACILITIES CRITERIA (UFC)

CONCRETE FLOOR SLABS ON GRADE SUBJECTED TO HEAVY LOADS

Any copyrighted material included in this UFC is identified at its point of use. Use of the copyrighted material apart from this UFC must have the permission of the copyright holder.

U.S. ARMY CORPS OF ENGINEERS (Preparing Activity)

NAVAL FACILITIES ENGINEERING COMMAND

AIR FORCE CIVIL ENGINEER SUPPORT AGENCY

Record of Changes (changes are indicated by \1\ ... /1/)

Change No.	Date	Location

This UFC supersedes TM 5-809-12/AFM 88-3Ch15, dated 25 August 1987. The format of this UFC does not conform to UFC 1-300-01; however, the format will be adjusted to conform at the next revision. The body of this UFC is the previous TM 5-809-12, dated 25 August 1987.

FOREWORD

\1\

The Unified Facilities Criteria (UFC) system is prescribed by MIL-STD 3007 and provides planning, design, construction, sustainment, restoration, and modernization criteria, and applies to the Military Departments, the Defense Agencies, and the DoD Field Activities in accordance with [USD\(AT&L\) Memorandum](#) dated 29 May 2002. UFC will be used for all DoD projects and work for other customers where appropriate. All construction outside of the United States is also governed by Status of forces Agreements (SOFA), Host Nation Funded Construction Agreements (HNFA), and in some instances, Bilateral Infrastructure Agreements (BIA.) Therefore, the acquisition team must ensure compliance with the more stringent of the UFC, the SOFA, the HNFA, and the BIA, as applicable.

UFC are living documents and will be periodically reviewed, updated, and made available to users as part of the Services' responsibility for providing technical criteria for military construction. Headquarters, U.S. Army Corps of Engineers (HQUSACE), Naval Facilities Engineering Command (NAVFAC), and Air Force Civil Engineer Support Agency (AFCESA) are responsible for administration of the UFC system. Defense agencies should contact the preparing service for document interpretation and improvements. Technical content of UFC is the responsibility of the cognizant DoD working group. Recommended changes with supporting rationale should be sent to the respective service proponent office by the following electronic form: [Criteria Change Request \(CCR\)](#). The form is also accessible from the Internet sites listed below.

UFC are effective upon issuance and are distributed only in electronic media from the following source:

- Whole Building Design Guide web site <http://dod.wbdg.org/>.

Hard copies of UFC printed from electronic media should be checked against the current electronic version prior to use to ensure that they are current.

AUTHORIZED BY:

DONALD L. BASHAM, P.E.
Chief, Engineering and Construction
U.S. Army Corps of Engineers

DR. JAMES W. WRIGHT, P.E.
Chief Engineer
Naval Facilities Engineering Command

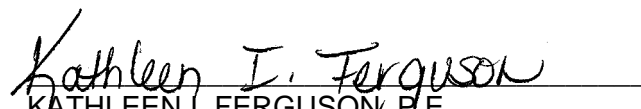
KATHLEEN I. FERGUSON, P.E.
The Deputy Civil Engineer
DCS/Installations & Logistics
Department of the Air Force

Dr. GET W. MOY, P.E.
Director, Installations Requirements and
Management
Office of the Deputy Under Secretary of Defense
(Installations and Environment)

ARMY TM 5-809-12
AIR FORCE AFM 88-3, Chap. 15

DEPARTMENTS OF THE ARMY AND
THE AIR FORCE TECHNICAL MANUAL

**CONCRETE FLOOR SLABS
ON GRADE SUBJECTED
TO HEAVY LOADS**

DEPARTMENTS OF THE ARMY, AND THE AIR FORCE

AUGUST 1987

TECHNICAL MANUAL
No.5-809-12
AIR FORCE MANUAL
No. 88-3, CHAPTER 15

HEADQUARTERS
DEPARTMENTS OF THE ARMY
AND THE AIR FORCE
WASHINGTON, D.C., 25 August 1987

CONCRETE FLOOR SLABS ON GRADE SUBJECTED TO HEAVY LOADS

CHAPTER 1. INTRODUCTION

Purpose 1-1 1-

Scope 1.2 1-

Definitions 1.3

Basic considerations 1-4

References 1-5

CHAPTER 2. BASIS OF FLOOR SLAB ON GRADE DESIGN

Stresses 2-1

Vehicle-imposed loads 2-2

Stationary live loads 2-3

Wall loads 2-4

CHAPTER 3. DETERMINATION OF FLOOR SLAB REQUIREMENTS

Vehicular loads 3-1 3-

Traffic distribution 3-2 3-

Stationary live loads 3-3

Wall loads 3-4

Unusual loads 3-5

CHAPTER 4. SITE INVESTIGATION

General 4-1 4-

Subgrade conditions 4-2

Environmental conditions 4-3

Concrete strength 4-4 4-

CHAPTER 5. DESIGN PROCEDURE

General 5-1 5-

Floor slab loads 5-2

Subgrade 5-3

Base courses 54

Reinforced Design 5-6

Steel reinforcement 5-5

Joint types and usage 5-7

Floor slab geometry 5-8

Fiber reinforced design 5-9

* This manual supersedes TM 5-809-12/AFM 88-3, Chapter 15, dated 1 April 1977.

TM 5-809-12/AFM 88-3, Chap. 15

	Page
APPENDIX A. REFERENCES	A-1
APPENDIX B. EQUATIONS FOR COMPUTING THE ALLOWABLE WALL LOADS NEAR CENTER OF SLAB OR NEAR KEYED OR DOWELED JOINTS	B-1
APPENDIX C. DESIGN EXAMPLES	C-1
BIBLIOGRAPHY	BIBLIO-1

LIST OF FIGURES

Figure 3-1	Widths of thickened slabs and slab edge conditions under wall loads	3-
5-1	Design curves for concrete floor slabs by design index	5-
5-2	Design curves for concrete floor slabs for heavy forklifts	5-
5-3	Reinforcement for odd-shaped slabs	5-
5-4	Design thickness for reinforced floor slabs	5-
5-5	Typical floor slab joint layout	5-
5-6	Contraction joints for reinforced and nonreinforced floor slabs	5-
5-7	Joint sealant details	5-
5-8	Contraction joint details	5-
5-9	Doweled construction joints for concrete floor slabs	5-
5-10	Keyed construction joints for concrete floor slabs	5-
5-11	Doorway slab design for vehicular traffic	5-
5-12	Isolation joints	5-
5-13	Thickened-edge joints	5-
5-14	Joints in concrete floor slabs	5-
5-15	Design curves for fiber-reinforced concrete floor slab by design index	5-
5-16	Design curves for fiber-reinforced concrete floor slab for heavy forklifts	5-
5-17	Deflection curves for fiber-reinforced concrete floor slabs	5-
5-18	Allowable deflection for jointed fiber- reinforced concrete floor slabs	5-

LIST OF TABLES

Table 3-1	Maximum allowable stationary live load	3-
3-2	Minimum thickness of thickened floor slab for wall load near center of	3-
	slab or near keyed or doweled joint	3-
3-3	Maximum allowable wall load near free edge	3-
4-1	Typical values of modulus of subgrade reaction	4-
5-1	Traffic categories for design index	5-
5-2	Recommended spacing of transverse contraction joints	5-
5-3	Dowel size and spacing	5-

CHAPTER 1

INTRODUCTION

1-1. Purpose.

This manual prescribes the criteria for the design of concrete floor slabs on grade in buildings for heavy loads and is applicable to all elements responsible for military construction. Heavy loads in buildings such as warehouses include moving loads, stationary live loads, and wall loads.

1-2. Scope.

Theoretical concepts, practical applications, basis of design, and design procedures for heavy loads are discussed in this manual. Related criteria for light-loaded areas such as office spaces are separately treated in TM 5-809-2/AFM 88-3, Chap. 2. Criteria for areas subjected to vibratory loadings are included in TM 5-81 8-1/AFM 88-7, Chap. 1. For design criteria outside the scope of this manual, industry standards are recommended.

1-3. Definitions.

The following definitions have been adopted for the manual:

a. Slab on grade. Concrete slab supported directly on foundation soil.

b. Light loads. Loads which consist of (comparable) forklift axle load of 5 kips or less and stationary live loads less than 400 pounds per square foot.

c. Heavy loads. Loads which consist of any one of the following: moving live loads exceeding a forklift axle load of 5 kips, stationary live loads exceeding 400 pounds per square foot, and concentrated wall loads exceeding 600 pounds per linear foot.

d. Wall load. Concentrated loads imposed by walls or partitions.

e. Dead load. All the materials composing the permanent structure, including permanent wall loads and all equipment that is fixed in position.

f. Live load. Loads imposed by the use and occupancy of the structure.

(1) *Moving live load.* Loads imposed by vehicular traffic such as forklift trucks.

(2) *Stationary live load.* Loads imposed by movable items such as stored materials.

g. Vibratory loads. Dynamic and/or oscillatory loading of significant magnitude.

h. Design load. The effects of stationary live, dead, and wall loads and moving live loads. Dead loads of floor slabs on grade are ignored.

i. Special soils. Soils which exhibit undesirable properties for construction uses such as high compressibility or swell potential.

j. Nonreinforced slab. Concrete slab resting on grade containing minimal distributed steel, usually of welded wire fabric (WWF), for the purpose of limiting crack width due to shrinkage and temperature change.

k. Reinforced slab. Concrete slab resting on grade containing steel reinforcement which consists of either a welded wire fabric or deformed reinforcing steel bars.

1-4. Basic considerations.

Concrete floor slabs on grade are subjected to a variety of loads and loading conditions. The design procedure includes determining slab thickness based on moving live loads and then checking adequacy of slab thickness for stationary live load. The design procedure separately includes determining thickness of slab under wall load. The entire design procedure is based on a working stress concept. Stresses induced by temperature gradients and other environmental effects are taken into account by the assignment of working stresses. Working stresses have been established empirically based on experience gained in roadway and airfield pavement performance data.

1-5. References.

Appendix A contains a list of references used in this document.

CHAPTER 2

BASIS OF FLOOR SLAB ON GRADE DESIGN

2-1. Stresses.

The structural design of a concrete floor slab on grade is primarily controlled by the stresses caused by moving live loads and in some cases the stationary loads. Stresses in floor slabs on grade resulting from vehicular loads are a function of floor slab thickness, vehicle weight and weight distribution, vehicle wheel or track configuration, modulus of elasticity and Poisson's ratio of concrete, and modulus of subgrade reaction of supporting material. The volume of traffic during the design life is important for fatigue considerations. The floor slab design procedure presented herein is based on limiting the critical tensile stresses produced within the slab by the vehicle loading, as in TM 5-822-6/AFM 88-7, Chap. 1. Correlation studies between theory, small-scale model studies, and full-scale accelerated traffic tests have shown that maximum tensile stresses in floor slabs will occur when vehicle wheels are tangent to a free edge. Stresses for the condition of the vehicle wheels tangent to an interior joint where the two slabs are tied together are less severe than a free edge because of the load transfer across the two adjacent slabs. In the case of floor slabs, the design can be based on the control of stress at interior joints. Exceptions to this assumption for interior joint loading occur when a wheel is placed at the edge at doorways or near a free edge at a wall.

2.2 Vehicle-imposed loads.

For determining floor slab design requirements, military vehicles have been divided into three general classifications: forklift trucks, other pneumatic and solid tired vehicles, and tracked vehicles. The relative severity of any given load within any of the three classifications is determined by establishing a relationship between the load in question and a standard loading. Floor slab design requirements are then established in terms of the standard load. Other stresses such as restraint stresses resulting from

thermal expansion and contraction of the concrete slab and warping stresses resulting from moisture and temperature gradients within the slab, due to their cyclic nature, will at times be added to the moving live load stresses. Provision for these stresses that are not induced by wheel loads is made by safety factors developed empirically from full-scale accelerated traffic tests and from the observed performance of pavements under actual service conditions.

2-3. Stationary live loads.

The maximum allowable stationary live load is limited by both the positive bending moment stress under the load and the negative bending moment stresses occurring at some distance from the load.

a. Positive bending moments. Stresses due to positive bending moment are relatively simple to compute by using Westergaard's analysis* of elastically supported plates. An appropriate safety factor is applied to determine allowable stresses due to these loads because environmentally imposed stresses must also be accounted for when considering stationary loads.

b. Negative bending moments. The effect of negative bending stress is somewhat more difficult to determine. A slab on an elastic subgrade will deform under loading somewhat like a damped sine curve in which the amplitude or deformation of successive cycles at a distance from the loading position decreases asymptotically to zero. Thus, there exists some critical aisle width where the damped sine curves from parallel loading areas are in phase and additive. In this situation, the negative bending moment stresses will become significant and must be considered. Therefore, allowable stationary live loads were established to include the effects of negative moment bending stresses. These calculations are reflected in the tabulated values of allowable stationary live loads.

* Westergaard's analysis is actually for plates on a liquid foundation, sometimes called a Winkler foundation. There is a distinct difference between the structural behavior of plates on a liquid and on an elastic foundation. In many textbooks, the term "beam on elastic foundation" is actually "beam on liquid foundation."

2-4. Wall loads.

There are situations where a wall is placed on a new thickened slab or- on an existing concrete floor slab on grade. Walls weigh from several hundred to several thousand pounds per linear foot. The design table used for determining thicknesses required under walls is developed by Staab (see Biblio) and

is based on the theory of a beam on a liquid foundation subjected to concentrated loads. Three loading conditions are considered: loads at the center of the slab, loads at a joint, and loads at the edge of the slab. The widths of thickened slabs are developed together with the recommended transitions.

CHAPTER 3

DETERMINATION OF FLOOR SLAB REQUIREMENTS

3-1. Vehicular loads.

The following traffic data are required to determine the floor slab thickness requirements:

- Types of vehicles
- Traffic volume by vehicle type
- Wheel loads, including the maximum single-axle and tandem-axle loading for trucks, forklift trucks, and tracked vehicles
- The average daily volume of traffic (ADV) which, in turn, determines the total traffic volume anticipated during the design life of the floor slab.

For floor slabs, the magnitude of the axle load is of far greater importance than the gross weight. Axle spacings generally are large enough so that there is little or no interaction between axles. Forklift truck traffic is expressed in terms of maximum axle load. Under maximum load conditions, weight carried by

the drive axle of a forklift truck is normally 87 to 94 percent of the total gross weight of the loaded vehicle.

For tracked vehicles, the gross weight is evenly divided between two tracks, and the severity of the load can easily be expressed in terms of gross weight. For moving live loads, axle loading is far more important than the number of load repetitions. Full-scale experiments have shown that changes as little as 10 percent in the magnitude of axle loading are equivalent to changes of 300 to 400 percent in the number of load repetitions.

3-2. Traffic distribution.

To aid in evaluating traffic for the purposes of floor slab design, typical forklift trucks have been divided into six categories as follows:

<i>Forklift Truck Category</i>	<i>Forklift Truck Maximum Axle Load, kips</i>	<i>Maximum Load Capacity, kips</i>
I	5 to 10	2 to 4
II	10 to 15	4 to 6
III	15 to 25	6 to 10
IV	25 to 36	10 to 16
V	36 to 43	16 to 20
VI	43 to 120	20 to 52

When forklift trucks have axle loads less than 5 kips and the stationary live loads are less than 400 pounds per square foot, the floor slab should be designed in accordance with TM 5-809-2/AFM 88-3, Chap. 2. Vehicles other than forklift trucks such as conventional trucks shall be evaluated by

considering each axle as one forklift truck axle of approximate weight. For example, a three-axle truck with axle loads of 6, 14, and 14 kips will be considered as three forklift truck axles, one in Category I and two in Category II. Tracked vehicles are categorized as follows:

<i>Forklift Truck Category</i>	<i>Tracked Vehicles Maximum Gross Weight, kips</i>
I	less than 40
II	40 to 60
III	60 to 90
IV	90 to 120

Categories for tracked vehicles may be substituted for the same category for forklift trucks.

3-3. Stationary live loads.

Floor slabs on grade should have adequate structural live loads. Since floor slabs are designed for moving live loads, the design should be checked for stationary live loading conditions. Table 3-1 lists values for maximum stationary live loads on floor slabs. For very heavy stationary live loads, the floor slab thicknesses listed in table 3-1 will control the design. Table 3-1 was prepared using the equation

$$w = 257.876s \sqrt{\frac{kh}{E}} \quad (\text{eq 3-1})$$

where

- w = the maximum allowable distributed stationary live load, pounds per square foot
- s = the allowable extreme fiber stress in tension excluding shrinkage stress and is assumed to be equal to one-half the normal 28-day concrete flexural strength, pounds per square inch

- k = the modulus of subgrade reaction, pounds per cubic inch
- h = the slab thickness, inches
- E = the modulus of elasticity for the slab (assumed to equal 4.0×10^6 pounds per square inch)

The above equation may be used to find allowable loads for combinations of values of s, h, and k given in table 3-1. Further safety may be obtained by reducing allowable extreme fiber stress to a smaller percentage of the concrete flexural strength have been presented by Grieb and Werner, Waddell, and Hammitt (see Biblio). The selection of the modulus of subgrade reaction for use in table 3-1 is discussed in paragraph 4-2d. The design should be examined for the possibility of differential settlements which could result from nonuniform subgrade support. Also, consideration of the effects of long-term overall settlement for stationary live loads may be necessary for compressible soils (see TM 5-818-1/AFM 88-3, Chap. 7).

Table 3-1. Maximum allowable stationary live load

Slab Thickness inches h	Stationary Live Load w in lb/ft ² for These Flexural Strengths of Concrete			
	550 lb in ²	600 lb in ²	650 lb in ²	700 lb in ²
6	868	947	1,026	1,105
7	938	1,023	1,109	1,194
8	1,003	1,094	1,185	1,276
9	1,064	1,160	1,257	1,354
10	1,121	1,223	1,325	1,427
11	1,176	1,283	1,390	1,497
12	1,228	1,340	1,452	1,563
14	1,326	1,447	1,568	1,689
16	1,418	1,547	1,676	1,805
18	1,504	1,641	1,778	1,915
20	1,586	1,730	1,874	2,018

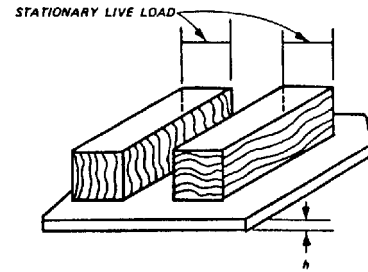

NOTE: Stationary live loads tabulated above are based on a modulus of subgrade reaction (k) of 100 lb/in³. Maximum allowable stationary live loads for other moduli of subgrade reaction will be computed by multiplying the above-tabulated loads by a constant factor. Constants for other subgrade moduli are tabulated below.

Modulus of Subgrade reaction	25	50	100	200	300
Constant factor	0.5	0.7	1.0	1.4	1.7

For other modulus of subgrade reaction values, the constant values may be found from the expression $\sqrt{k/100}$.

3-4. Wall loads.

Floor slabs on grade should have adequate thickness to carry wall loads. Tables 3-2 and 3-3 show the minimum thicknesses of thickened slabs for various wall loads. The equations used to compute these values are included in appendix B. When slab thickness required for wall loads exceeds that required for moving live loads or stationary live loads, the slab will be thickened in accordance with figure 3-1. The safety factor for the design was considered by using a reduced allowable tensile stress of the concrete, σ_t , which was computed using the equation $\sigma_t = 1.6 \sqrt{f'_c}$, where f'_c is the ultimate compressive strength of the concrete. If wall loads exceed the tabulated values shown in table 3-2, separate wall footings are suggested. Figure 3-1a shows the widths of thickened slabs when the interior wall loads are near the slab center. A recommended transition is also shown. The thickened slab width is determined by the same theory as the wall loads. The slab under the wall is widened to the point where the stress in the thinner slab section does not exceed the allowable tensile stress of $1.6 \sqrt{f'_c}$. Figure 3-1b shows a slab loaded near a keyed or doweled edge. Figure 3-1c shows a recommended slab thickening for a slab loaded near a free edge. The width of the thickened edge varies depending upon the width of the wall.

3-5. Unusual loads.

Information regarding floor slab requirements for special purpose ordnance, engineer, or transport vehicles producing loads significantly greater than those defined herein should be requested from Headquarters, Department of the Army (HQDA) (DAEN-ECE-G) Washington, DC 20314-1000 or Headquarters, Air Force Engineering and Services Center (DEMP), Tyndall MB, Fla. 32403.

Table 3-2. Minimum thickness of thickened floor slab for wall load near center of slab or near keyed or doweled joint

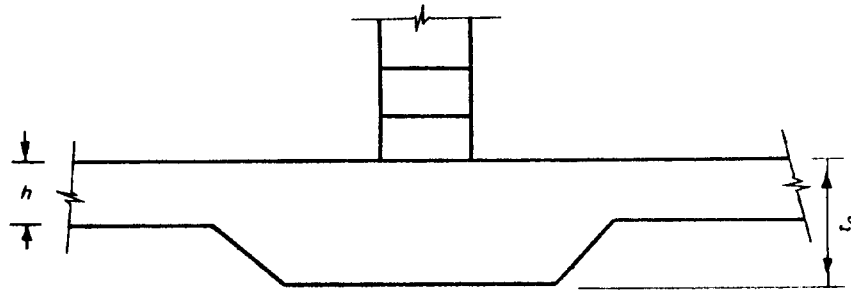

Thickness of Thickened Floor Slab, t_e , (inches)	Slab Line Load Capacity, P , (lb/lin ft)			
	Flexural Strength ^a of Concrete (lb/in ²)			
	550	600	650	700
4	425	455	485	510
5	565	600	640	675
6	710	755	805	850
7	860	920	975	1,030
8	1,015	1,080	1,150	1,215
9	1,175	1,255	1,330	1,410
10	1,340	1,430	1,520	1,605

NOTE: The allowable wall loads are based on a modulus of subgrade reaction (k) of 100 pounds per cubic inch. The thickness of the thickened slab will be computed by multiplying the above thicknesses by a constant factor. Constants for other subgrade moduli are tabulated below.

Modulus of Subgrade reaction k	25	50	100	200	300
Constant factor	1.3	1.1	1.0	0.9	0.8

For other modulus of subgrade reaction values the constant values may be found from $\sqrt[5]{100/k}$.

^aFor this application the flexural strength of concrete was assumed equal to $9\sqrt{f'_c}$ where f'_c is the specified compressive strength of concrete (lb/in²).

Table 3-3. Maximum allowable wall load near free edge

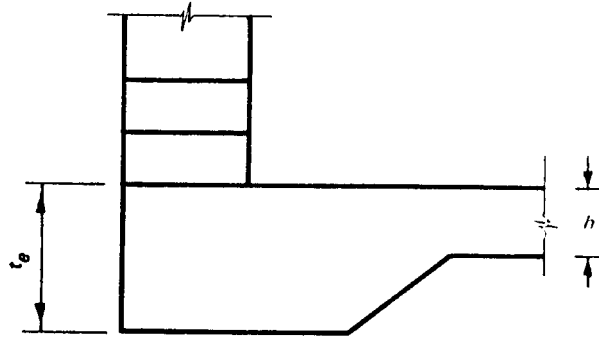

Thickness of Thickened Slab, t_e (inches)	Slab Line Load Capacity, P , (lb/lin ft)			
	Flexural Strength ^a of Concrete (lb/in ²)			
	550	600	650	700
4	330	355	375	395
5	435	465	495	525
6	550	585	620	660
7	665	710	755	800
8	785	840	890	945
9	910	975	1,035	1,090
10	1,040	1,110	1,180	1,245

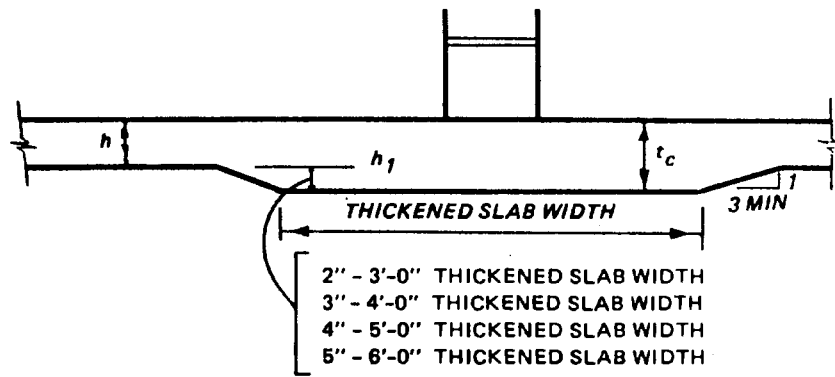

a). SLABS LOADED NEAR THE CENTER

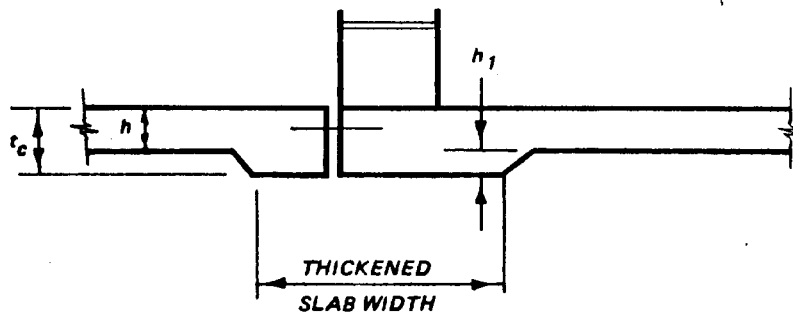

b). SLABS LOADED NEAR A KEYED OR DOWELED JOINT

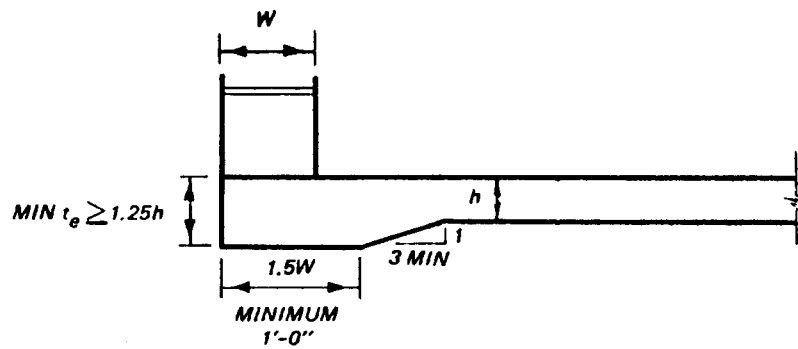

c). SLABS LOADED NEAR A FREE EDGE

Figure 3-1. Widths of thickened slabs and slab edge conditions under wall loads.

CHAPTER 4

SITE INVESTIGATION

4-1. General

Once the floor slab load capacity requirements have been established, an investigation of the existing conditions at the site must be made. Conditions to be considered include an investigation of the subgrade, climatic conditions, the need for and availability of base course materials, and the concrete strength properties likely to be encountered in the locale.

4-2. Subgrade conditions.

a. Importance of subgrade conditions. The subgrade provides a foundation for supporting the floor slab and base courses. As a result, the required floor slab thickness and the performance obtained from the floor slab during its design life will depend in a large part, on the uniformity and bearing capacity of the subgrade. It is desirable, if economically feasible, to thoroughly investigate the subgrade to assess the maximum support potential for the particular subgrade. In unheated structures, the possibility of frost heave emphasizes the importance of uniformity of soil conditions under the floor slab.

b. Initial investigation. Preliminary investigations of subgrade conditions at the site of proposed construction should be performed to determine the engineering characteristics of the subgrade soils and the extent of any peculiarities of the proposed site. The general suitability of the subgrade soils is to be based on classification of the soil, moisture density relationships, expansive characteristics, susceptibility to pumping, and susceptibility to detrimental frost action. A careful study of the service history of existing floor slabs on similar subgrade materials in the locality of the proposed site should be made. Factors such as ground water, surface infiltration, soil capillarity, topography, rainfall, drainage conditions, and the seasonal change of such factors also may affect the support rendered by the subgrade.

c. Exploration and classification. If field reconnaissance and analysis of existing subsurface information are insufficient to provide the necessary data for floor-slab design, an exploration program should be initiated according to provisions of TM 5-81 8-1/AFM 88-3, Chap. 7. All soils should be classified in accordance with MIL-STD-619. Sufficient investigations should be performed at the proposed site to facilitate the classification of all soils that will be used or removed during construction; other pertinent descriptive information should also be included.

d. Performance data. For the design of rigid floor slabs in areas where no previous experience regarding floor slab performance is available, the modulus of subgrade reaction k to be used for design purposes is determined by the field plate-bearing test. A description of the procedure to be followed for this test and the method for evaluating test results are given in MIL-STD-621. Where performance data from existing floor slabs on grade are available, adequate values for k usually can be estimated on the basis of soil type, drainage conditions, and frost conditions that prevail at the proposed site. Table 4-1 lists typical values of modulus subgrade reaction for various soil types and moisture contents. Values shown may be increased slightly if the density is greater than 95 percent maximum CE 55 density, except that a maximum of 500 pounds per cubic inch will be used for design. These values should be considered as a guide only, and their use in lieu of the field plate-bearing test is left to the discretion of the engineer. The fact that the materials are shown in the table does not indicate suitability for use. Suitability must be determined for the particular job conditions.

Table 4-1. Typical values of modulus of subgrade reaction

Types of Materials	Modulus of Subgrade Reaction, k, in lb/in ³ for Moisture Contents of							
	1	5	9	13	17	21	25	Over
	to	to	to	to	to	to	to	
	4%	8%	12%	16%	20%	24%	28%	29%
Silts and clays Liquid limit > 50 (OH, CH, MH)	--	175	150	125	100	75	50	25
Silts and clays Liquid limit < 50 (OL, CL, ML)	--	200	175	150	125	100	75	50
Silty and clayey sands (SM & SC)	300	250	225	200	150	--	--	--
Gravelly sands (SW & SP)	300+	300	250	--	--	--	--	--
Silty and clayey gravels (GM & GC)	300+	300+	300	250	--	--	--	--
Gravel and sandy gravels (GW & GP)	300+	300+	--	--	--	--	--	--

NOTE: k values shown are typical for materials having dry densities equal to 90 to 95 percent of the maximum CE 55 density. For materials having dry densities less than 90 percent of maximum CE 55 density, values should be reduced by 50 lb/in³, except that a k of 25 lb/in³ will be the minimum used for design.

4-3. Environmental conditions.

a. Freezing and thawing. Special additional design considerations and measures are necessary where freezing and thawing may occur in underlying soils. The effects of such occurrences, which are termed “frost action,” include surface heaving during freezing and loss of bearing capacity upon thawing. Detrimental frost action is the result of the development and/or thawing of segregated ice in underlying soils. Potential difficulties from frost action exist whenever a source of water is available to a frost-susceptible soil which is subject to subfreezing temperatures during a portion of the year. Conditions necessary for the development of ice segregation in soils together with a description of the ice segregation process and the detrimental effects of frost action are given in TM 5-818-2/AFM 88-6, Chap. 4.

b. Cold storage facilities. A somewhat different problem is encountered in cold storage facilities where a structure in contact with the ground is maintained at subfreezing temperature. Thus, frost action under such structures is a long-term rather than a seasonal phenomenon, and deep frost penetration will eventually result, even in areas where subfreezing ground temperatures are not naturally experienced, unless insulation or provisions for circulation of warm air beneath the slab are provided in design. Recommended as a reference is American Society of Heating, Refrigerating, and Air-Conditioning Engineering ASHRAE Handbook and Product Directory, Equipment, and Applications, (see Biblio). It should be kept in mind that insulation may merely slow frost penetration. It does not prevent heat flow.

c. Permafrost. Since construction alters the existing thermal regime in the ground, an additional problem is encountered in regions where heat flow from the facility may result in the progressive thawing of perennially frozen ground (permafrost). Thermal degradation of permafrost which contains masses of ice will result in subsidence as well as reduction in bearing capacity. Both may be severe. The most widely employed, effective, and

economical means of maintaining a stable thermal regime in permafrost under slabs-on-grade is by means of a ventilated foundation. Provision is made for ducted circulation of cold winter air between the insulated floor and underlying ground. The air circulation serves to carry away the heat both from the foundation and the overlying building, freezing back the upper layers of soil which were thawed the preceding summer. The characteristics of permafrost and engineering principles in permafrost regions are described in TM 5-852-1/AFM 88-19, Chap. 1, and TM 5-852-4.

d. Applicable technical manuals. Where freezing and/or thawing may occur in underlying soils, slab design will be in accordance, as applicable, with TM 5-818-2/AFM 88-6, Chap. 4 and TM 5-852-4. Thermal computation procedures are detailed in TM 5-852-6/AFM 88-19, Chap. 6.

4-4. Concrete strength.

a. General. For a given water-cement ratio, the concrete strength likely to be obtained in a given locale depends primarily on the aggregate sources available. Maximum particle size and quality of the coarse aggregate will have a pronounced effect on concrete strength as will the gradation of the blended coarse and fine aggregate. In general, aggregates of the bankrun variety, as opposed to crushed aggregates, will produce a lower-strength concrete due to particle shape. Specified concrete strength should be sufficient to provide high wear resistance properties, constructability, and a reasonably high flexural stress to attain the greatest economy in the design. A study should be made of the strengths likely to be encountered, since specifying an unusually high-strength concrete mix may result in a higher material cost for the project.

b. Traffic types. The minimum concrete compressive strength for floors subjected to pneumatic tired traffic will be 4,000 pounds per square inch; for floors subjected to abrasive traffic such as steel wheels, the minimum concrete compressive strength will be 5,000 pounds per square inch.

CHAPTER 5 DESIGN PROCEDURE

5-1. General.

Once the floor-slab design requirements have been established, i.e., the type of loadings, including wall loads and both stationary live and moving live loads, the requirements are translated into meaningful design data. These design data are then compared with the existing condition data, and a floor slab design is evolved. The design procedure covers subgrade conditions, steel reinforcing, and various details such as jointing.

5-2. Floor slab loads.

a. Traffic loadings. In order to satisfy requirements of different types of vehicles and traffic volumes, all Category I, II, and III traffic has been expressed in terms of equivalent operations of a basic axle loading. The basic loading was assumed to be an 1 8,000-pound single-axle load with two sets of dual wheels spaced 58-1/2 inches apart with 13-1/2 inches between dual wheels. It should be noted that the basic loading was arbitrarily selected to provide a reasonable spread in the loadings and traffic volumes likely to be encountered under normal conditions. A design index (DI) was devised

which expresses varying axle loads and traffic volume in terms of relative severity. The DI ranges from 1 to 10 with the higher number indicating a more severe design requirement. The basic loading described above was used to assign and rank the DI's. More information concerning the DI can be found in TM 5-822-6/AFM 88-7, Chap. 1. Table 5-1 shows the DI's for various traffic volumes. Thickness requirements for floor slabs which contain only temperature reinforcement for the ten DI's are shown in figure 5-1. The floor-slab thickness requirements are a function of concrete strength and subgrade modulus and DI. Larger forklifts having axle loads greater than 25 kips are treated separately. The required slab thickness for pavements designed for these loads are not significantly affected by vehicles having axle loads less than 25 kips (trucks, cars, buses, and small forklifts). These light loads are therefore ignored in determining requirements for pavements carrying axle loads greater than 25 kips. The thickness requirements for these loads are shown in figure 5-2.

Table 5-1. Traffic categories for design index

Maximum Operations Per Day Over 25 Years	Load	Design Index
50	10-kip axle-load forklift truck	4
250	10-kip axle-load forklift truck	5
10	15-kip axle-load forklift truck	
250	10-kip axle-load forklift truck	7
100	15-kip axle-load forklift truck	
250	15-kip axle-load forklift truck	8
5	25-kip axle-load forklift truck	

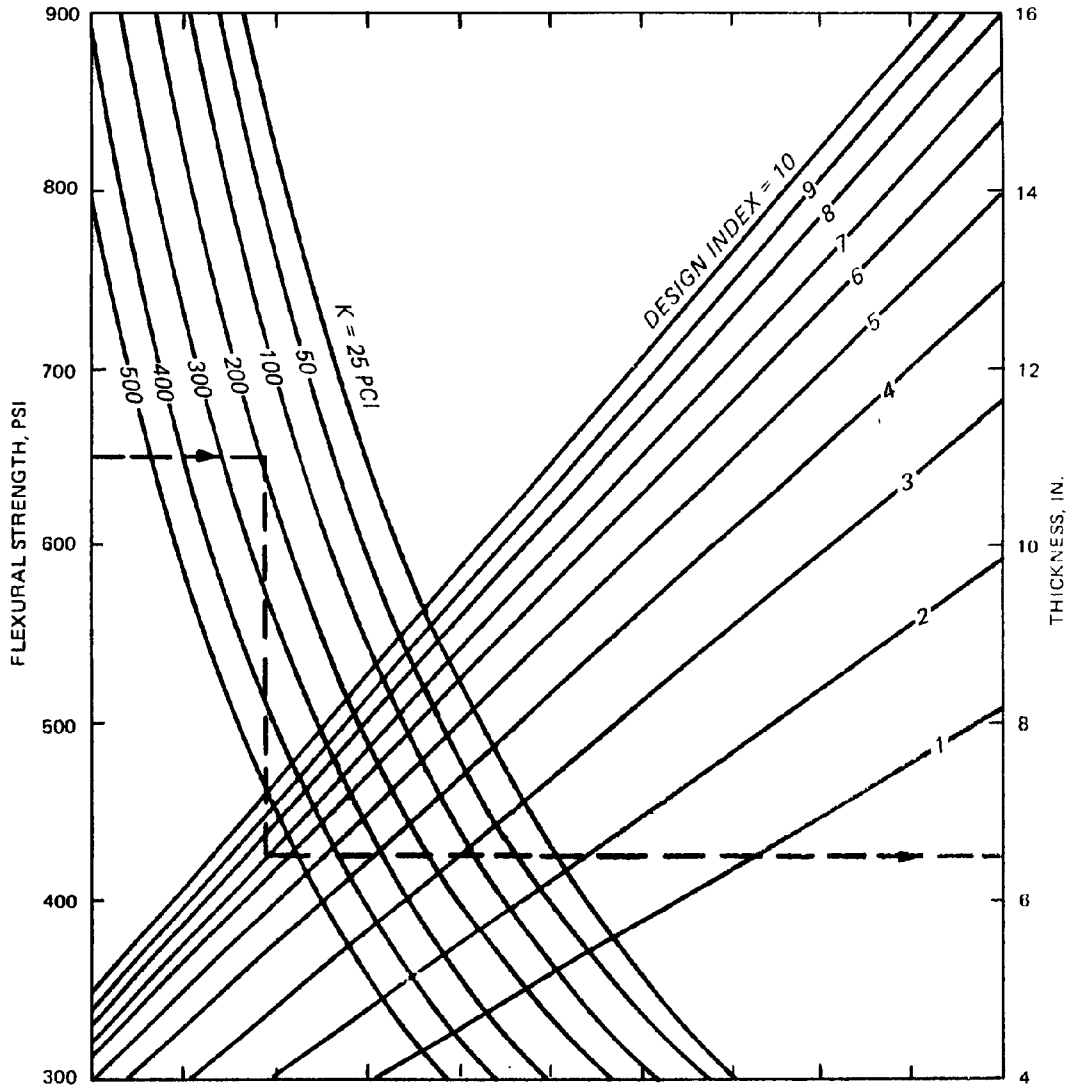

Figure 5-1. Design curves for concrete floor slabs by design index.

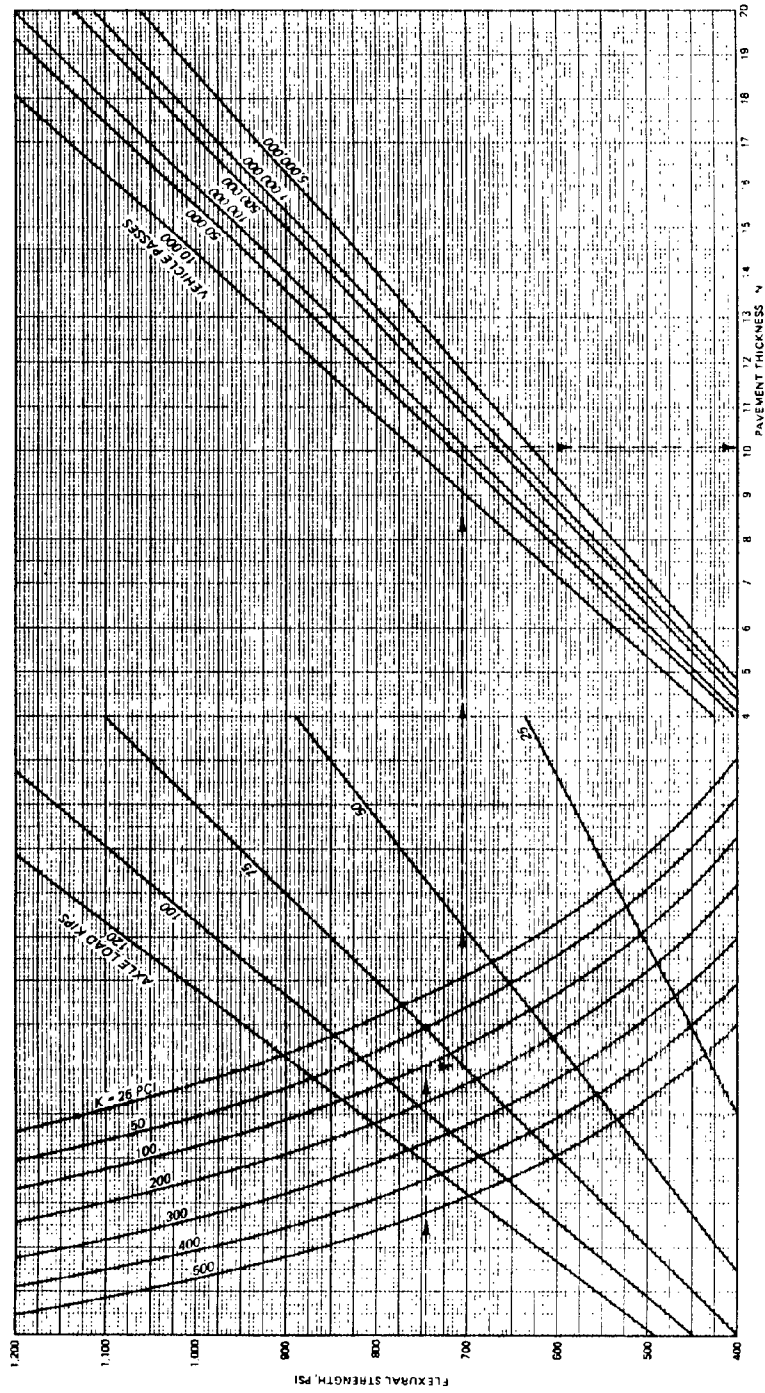

Figure 5-2. Design curves for concrete floor slabs for heavy forklifts.

b. Stationary live loads. Stationary live loads are expressed in terms of maximum allowable pounds per square foot. These loadings are given in table 3-1. The method used to determine the allowable loads is based on the concrete flexural strength, the slab thickness, and the modulus of subgrade reaction. Entering table 3-1 with the flexural strength and the slab thickness, the allowable stationary live load can be selected. Based on the modulus of subgrade reaction, the load is adjusted using the constant factor given in the note (table 3-1).

c. Wall loads. Stationary-partition loads are expressed in terms of pounds per linear foot. These loadings are given in table 3-2. The method used to determine thickness, t_c , of the thickened floor slab is based on the concrete flexural strength, the load, and the modulus of subgrade reaction. Entering table 3-2 with the flexural strength of the concrete and the load, the concrete thickness is selected, based on a modulus of subgrade reaction of 100 pci. The thickness is adjusted using the constant factor given in the note (table 3-2), for other subgrade moduli.

d. Design procedures for stabilized foundations.

(1) *Soil stabilization or modification.* Soils that have been treated with additives such as cement, lime, fly ash, or bitumen are considered to be either stabilized or modified. A stabilized soil is one that shows improvement in load-carrying capability and durability characteristics. A modified soil is one that shows improvement in its construction characteristics but which does not show an increase in the strength of the soil sufficiently to qualify as a stabilized soil. The principal benefits of soil modification or stabilization include a stable all-weather construction platform and a reduction of rigid pavement thickness requirements when applicable, swell potential, and susceptibility to pumping and strength loss due to moisture.

(2) *Requirements.* The design of the stabilized or modified layers will follow TM 5-822-4, and TM 5-818-2/AFM 88-6, Chap. 4. To qualify as a stabilized layer, the stabilized material must meet the unconfined compressive strength and durability requirements in TM 5-882-4; otherwise, the layer is considered to be modified.

(3) *Thickness design.* The thickness requirements for a rigid pavement on a modified soil foundation will be designed as if the layer is unbounded using the k value measured on top of the modified soil layer. For stabilized soil layers, the treated layer will be considered to be a low-strength base pavement and the thickness determined using the following modified partially bonded rigid overlay

pavement design in equation 5-1:

$$h_o = \sqrt[1.4]{h^{1.4} - \left(0.0063 \sqrt[3]{E_f h_s}\right)^{1.4}} \quad (\text{eq 5-1})$$

where

h_o = thickness of rigid pavements overlay required over the stabilized layer, inches

h = thickness of rigid pavement from design chart (fig. 5-1) based on k value of unbound material, inches

E_f = flexural modulus of elasticity (as determined by ASTM C 78)

h_s = thickness of stabilized layer, inches

e. Design Examples. Example design problems can be found in appendix C.

5-3. Subgrade.

a. Compaction. Compaction improves stability of most subgrade soils and provides a more uniform foundation for the floor slabs or base course. Method 100 of MIL-STD-621, Compaction Effort CE 55, should be used to determine the compaction characteristics of the subgrade soils. During construction, prolonged exposure of the subgrade to the atmosphere may allow overwetting or and drying therefore should not be allowed.

b. Cut sections. With the exception of areas of special soil, the top 6 inches of subgrade in cut sections should be scarified and moistened to approximately optimum moisture content and compacted. Cohesive subgrade soils should be compacted to a minimum of 90 percent of CE 55 maximum density and cohesionless soils to a minimum percent of CE 55 maximum density.

c. Fill sections. With the exception of fill composed of special soils, all fills composed of cohesive materials should be compacted to minimum of 90 percent of CE 55 maximum and all fills composed of cohesionless materials should be compacted to a minimum of 95 percent of CE 55 maximum density. Some adjustment., for compaction requirements may be necessary ;for fills of expansive soils..

d. Cut-to-fill sections. When a rigid floor slab is located partially on a fill area and partially on a cut area, the compaction. requirements set forth in the preceding paragraphs should be followed. The depth of subgrade compaction in the cut area should be increased to 12 inches.

e. Nonuniformity. Where it is not possible to create uniform subgrade conditions by the methods described herein, the slab design can be varied throughout the project to maximize economy. Concrete flexural strength, percent reinforcing steel, and slab thickness can all be adjusted to provide a design which is balanced in terms of service life. The specific combinations to be used will depend upon local conditions and costs, and selection of design alternatives is left to the discretion of the design engineer.

f. Special soils. Although compaction increases the stability and strength of most soils, some soil types show a marked decrease in stability when scarified, worked, and rolled. Also, there are some soils that shrink excessively during dry periods and expand excessively when allowed to absorb moisture. In general, these are inorganic clays of relatively high plasticity usually classified as CH soils. Special types of soils are discussed in TM 5-825-2/AFM 88-6, Chap. 2, TM 5-818-1/AFM 88-3, Chap. 7, and TM 5-818-7.

g. Back filling. Special care should be exercised in backfill areas around walls and columns to ensure compliance with compaction requirements outlined in the above paragraphs. Backfilling around walls and columns should be performed with pneumatic tampers, gasoline-powered tampers, and other mechanized hand-operated devices. Soil moisture content and lift thickness should be carefully controlled to ensure that compaction requirements are met through the full depth of the backfill.

h. Treatment of unsuitable materials. Soils designated as unsatisfactory for subgrade use by MIL-STD-619 should be removed and replaced. The depth to which such undesirable soils should be removed depends on the soil type, drainage conditions, type of material stored, magnitude of tolerable differential settlement, and depth of freezing-temperature penetration. The depth of removal and replacement should be determined by the engineer on the basis of judgement and previous experience and with due consideration of the traffic to be served as well as the costs involved. In some instances, unsatisfactory or undesirable soils may be improved economically by stabilization with such materials as cement, fly ash, lime, or certain chemical additives whereby the characteristics of the composite material become suitable for use as subgrade. Criteria for soil stabilization are given in TM 5-822-4. Subgrade stabilization, however, should not be attempted unless the cost reflects corresponding savings in base course, floor slabs, or drainage facilities construction and is approved by HQDA (DAEN-ECE-G) Washington, DC 2031 4-1 000 or Headquarters, Air Force Engineering Services Center (DEMP), Tyndall AFB, Fla. 32403.

5-4. Base courses.

a. Requirements. Base courses may be required under rigid floor slabs to provide protection against detrimental frost action, drainage, a suitable working platform for the construction operation during adverse weather conditions, and additional support to the floor slab. In any of the above-mentioned applications for base courses, an economic study is required to determine base course requirements in floor-slab design. The economic study will typically include costs of base course materials such as hauling and required floor-slab thickness with and without base course. Consideration should also be given to the use of the floor slab, i.e., what material is to be stored and what operations are likely to occur on the floor slab. These considerations will also have an impact on whether to include a base course.

b. Compaction. Where base courses are used, the base-course materials should be compacted in accordance with the criteria given above. With this in mind, note that compaction of thin base courses placed on yielding subgrades to high densities is difficult.

c. Drainage. Adverse moisture conditions resulting from high water table and subsoils subject to capillary action may cause damage to floor covering and stored material. If the subgrade soils provide for movement of water by capillary flow (CH, CL, MH, and ML types) and the ground-water table is less than 5 feet from the final grade, a minimum thickness of 6 inches of free-draining base course will be required. Base courses for drainage will not be required under conditions of deep ground-water table. Positive drainage is to be provided to ensure against water being trapped beneath the pavement. The floor should be protected against the migration of water vapor through the slab and joints. Water vapor damage is to be prevented by an impermeable membrane placed on the subgrade prior to concrete placement. Such vapor barriers shall be installed even in conjunction with base courses if moisture-susceptible floor coverings or conduits are present. See TM 5-809-2/AFM 88-3, Chap. 2 for embedment of conduits.

d. Materials. If conditions indicate that a base course is desirable, a thorough investigation should be made to determine the source, quantity, and characteristics of the available materials. A study should be made to determine the most economical thickness of material for a base course that will meet the requirements. The base course may consist of natural materials, processed materials, or stabilized materials as defined in TM 5-882-4. The material selected should be the one that best accomplishes

the intended purpose of the base course. In general, the base course material should be well-graded high-stability material. TM 5-822-6/AFM 88-7, Chap. 1 and TM 5-818-2/AFM 88-6, Chap. 4 provide requirements for base courses for additional support and frost action. If the base course is for drainage, the maximum particle size shall be 1-1/2 inches, and no particles shall be smaller than the No. 4 sieve size. If a free-draining, open-graded subbase is used, a filter layer may be placed under the base course to prevent pumping action and subgrade intrusion. Coarse aggregate shall have a percentage of wear by the Los Angeles abrasion test of not more than 50. Uniform high-quality materials shall be used. Weakly cemented rocks and most shales should not be used; an exception would be baked shales occurring adjacent to intrusive dikes. The frost susceptibility criterion listed previously in chapter 4 is also applicable to base course materials. Durability will be checked if the base aggregate will be exposed to frost. Aggregates that break down excessively when subjected to freeze-thaw cycles will not be used.

5-5. Steel reinforcement.

Under certain conditions, concrete pavement slabs may be reinforced with welded wire fabric or deformed bar mats arranged in a square or rectangular grid. The advantages in using steel reinforcement include: (a) a reduction in the required slab thickness usually is permissible; (b) wider spacing between transverse contraction joints may be used; (c) the width of crack opening is controlled, with the result that load transmission is maintained at a

high level at these points, and objectionable material is prevented from infiltrating the cracks; and (d) differential settlement due to nonuniform support or frost heave is reduced materially. Guidance relative to the use of reinforced pavement is discussed in the following paragraphs.

a. Subgrade conditions. Reinforcement may be used to control cracking in rigid pavements found on subgrades where differential vertical movement is a definite potential (for example, foundations with definite or borderline frost susceptibility that cannot feasibly be made to conform to conventional frost design requirements.)

b. Economic considerations. For the general case, reinforced rigid pavements will not be economically competitive with nonreinforced rigid pavements of equal load-carrying capacity, even though a reduction in pavement thickness is possible. Alternate bids, however, should be invited if reasonable doubt exists on this point.

c. Nonreinforced slabs. In otherwise nonreinforced floor slabs, steel reinforcement should be used for the conditions below.

(1) Odd-shaped slabs. Odd-shaped slabs should be reinforced using a minimum of 0.06 percent of steel in directions normal to each other over the entire area of the slab. An odd-shaped slab is considered to be one in which the longer dimension exceeds the shorter dimension by more than 25 percent or a slab which essentially is neither square nor rectangular. Figure 5-3 presents an example of reinforcement required in odd-shaped slabs.

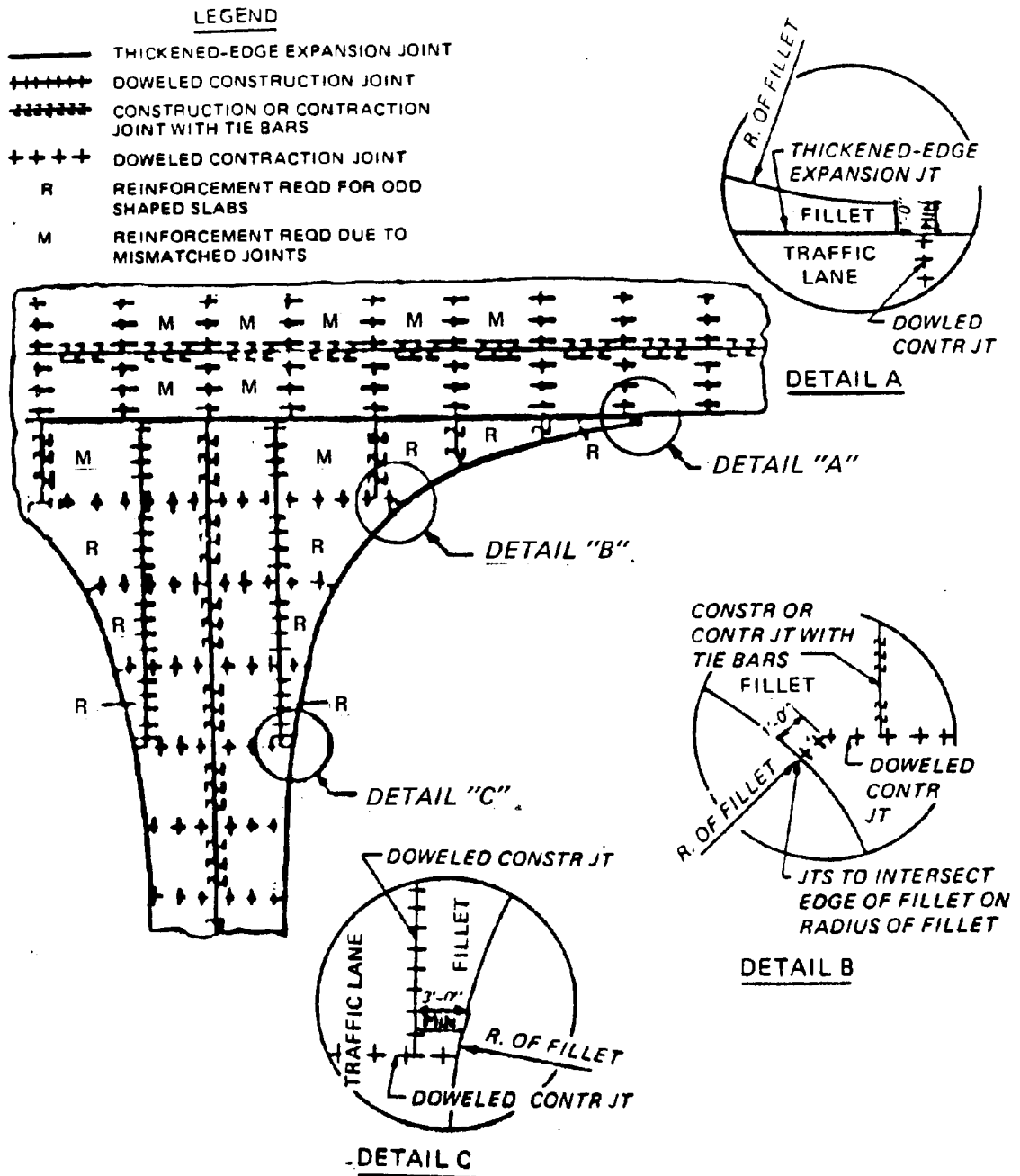

Figure 5-3. Reinforcement for odd-shaped slabs.

(2) *Mismatched joints.* A partial reinforcement of slab is required where the joint patterns of abutting or adjacent floor slabs do not match, and when the pavements are not positively separated by an expansion or slip-type joint. The floor slab directly opposite the mismatched joint should be reinforced with a minimum of 0.06 percent of steel in directions normal to each other for a distance of 3 feet back from the juncture, and for the full width or length of the slab in a direction normal to the mismatched joint. Mismatched joints normally will occur at intersections of floor slabs or between regular floor slab and fillet areas (fig 5-3).

d. Other uses. Reinforced and continuously reinforced floor slabs may be considered for reasons other than those described above provided a report containing a justification of the need for reinforcement is prepared and submit for approval to HQDA (DAEN-ECE-G), Washington, DC 20314-1 000, or Headquarters, Air Force Engineering and Services Center (DEMP), Tyndall AFB, Fla. 32403.

5-6. Reinforced design.

a. Thickness design on unbonded base or subbase. The design procedure for reinforced concrete floor slabs uses the principle of allowing a reduction in the required thickness of nonreinforced concrete floor slab due to the presence of the steel reinforcing. The design procedure has been developed empirically from a limited number of prototype test pavements subjected to accelerated traffic testing. Although it is anticipated that some cracking will occur in the floor slab under the design traffic loadings, the steel reinforcing will hold the cracks tightly closed. The reinforcing will prevent spalling or faulting at the cracks and provide a serviceable floor slab during the anticipated design life. Essentially, the design method consists of

determining the percentage of steel required, the thickness of the reinforced floor slab, and the maximum allowable length of the slabs. Figure 5-4 presents a graphic solution for the design of reinforced floor slabs. Since the thickness of a reinforced floor slab is a function of the percentage of steel reinforcing, the designer may determine the required percentage of steel for a predetermined thickness of floor slab or determine the required thickness of floor slab for a predetermined percentage of steel. In either case, it is necessary first to determine the required thickness of nonreinforced floor slab by the method outlined previously (para 5-2) for non reinforced floor slabs. The exact thickness (to the nearest 1/10 inch) of the floor slab, h , is then used to enter the nomogram in figure 5-4. A straight line is then drawn from the value of h to the value selected for the thickness of reinforced floor slab, h_r , and extended to the required percentage of reinforcing steel, S , or drawn from the value h to the value selected for the percentage of reinforcing steel, and extended to the thickness, h_r . The thickness, h_r , will always be equal to or less than the thickness, h . It should be noted that the S value indicated in figure 5-4 is the percentage to be used in the longitudinal direction only. For normal designs, the percentage of nonreinforcing steel used in the transverse direction will be one-half of that to be used in the longitudinal direction. Once the h_r and S values have been determined, the maximum allowable slab length L is obtained from the intersection of the straight line and the scale of L . Provision also is made in the nomograph for adjusting L on the basis of the yield strength f_s of the reinforcing steel. Difficulties may be encountered in sealing joints between very long slabs because of large volumetric changes caused by temperature changes.

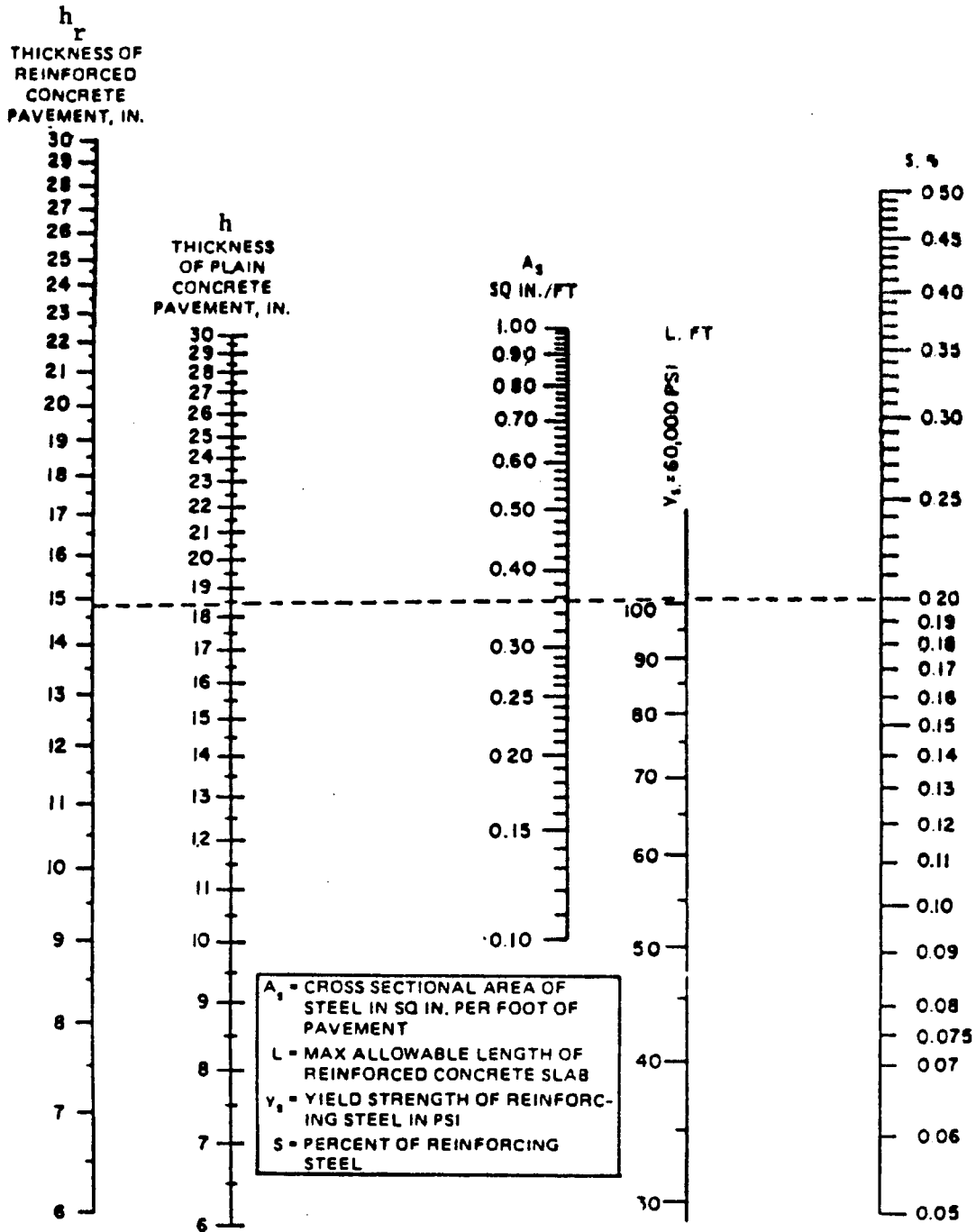

REINFORCED CONCRETE PAVEMENT DESIGN

NOTE: MINIMUM THICKNESS OF REINFORCED CONCRETE FLOOR SLABS WILL BE 6 IN.

Figure 5-4. Design thickness for reinforced floor slabs.

TM 5-809-12/AFM 88-3, Chap. 15

b. Thickness design on stabilized base or sub-grade. To determine the thickness requirements for reinforced concrete floor slabs on a stabilized foundation, it is first necessary to determine the thickness of nonreinforced concrete floor slab required for the design conditions. This thickness of nonreinforced floor slab is determined by the procedures set forth in paragraph 5-2*d*. Figure 5-4 is then entered with the values of h , h_r , and S

c. Limitations. The design criteria for reinforced concrete floor slabs on grade are subject to the following limitations:

(1) No reduction in the required thickness of nonreinforced floor slabs should be allowed for percentages of steel less than 0.05 percent.

(2) No further reduction in the required thickness of nonreinforced floor slabs should be allowed over that indicated in figure 5-4 for 0.50 percent steel, regardless of the percentage of steel used.

(3) The maximum length L of reinforced floor slabs should not exceed 75 feet regardless of the percentage of steel, yield strength of the steel, or thickness of the pavement.

(4) The minimum thickness of reinforced floor slabs should be 6 inches.

d. Reinforcing steel.

(1) *Type.* The reinforcing steel for floor slabs

may be either deformed bars or welded wire fabric. Specifications for both types of reinforcement are given in TM 5-825-3/AFM 88-6, Chap. 3.

(2) *Placement.* Placement of the reinforcing steel in floor slabs should follow the criteria given in TM 5-825-3/AFM 88-6, Chap. 3. In addition, the following criteria regarding the maximum spacing of reinforcement should be observed. For welded wire fabric, the maximum spacing of the longitudinal wires and transverse wires should not exceed 6 inches and 12 inches, respectively; for bar mats, the maximum spacing of the longitudinal bars and the transverse bars should not exceed 15 inches and 30 inches, respectively.

5-7. Joint types and usage.

Joints are provided to permit contraction and expansion of the concrete resulting from temperature and moisture changes, to relieve warping and curling stresses due to temperature and moisture differentials, to prevent unsightly, irregular breaking of the floor slab; as a construction expedient, to separate sections or strips of concrete placed at different times; and to isolate the floor slab from other building components. The three general types of joints are contraction, construction, and isolation. A typical floor-slab joint layout is shown in figure 5-5.

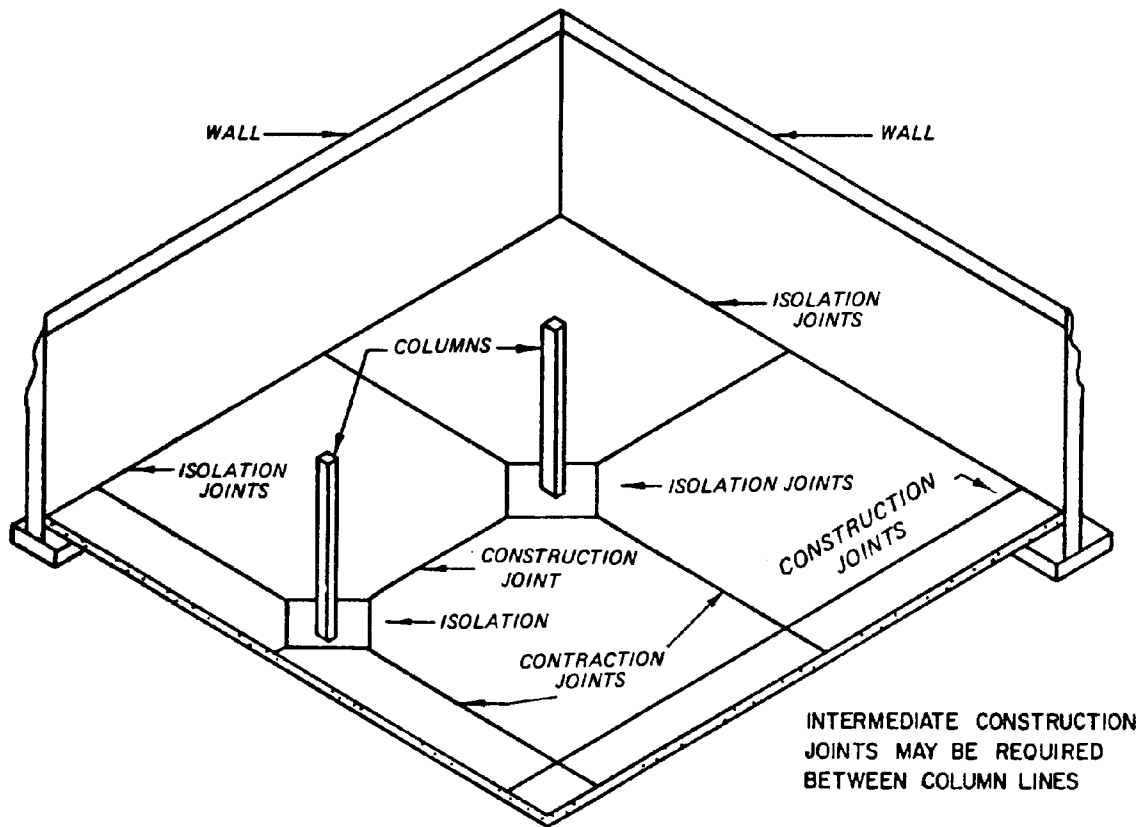
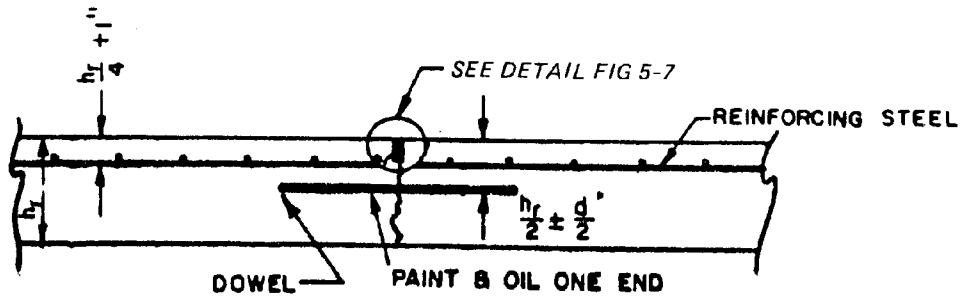

Figure 5-5. Typical floor slab joint layout.

a. Contraction joints.

Weakened-plane contraction joints are provided to control cracking in the concrete and to limit curling or warping stresses resulting from drying shrinkage and contraction and from temperature and moisture gradients in the slab, respectively. Shrinkage and contraction of the concrete causes slight cracking and separation of the slabs at the weakened planes, which will provide some relief from tensile forces resulting from foundation restraint and compressive

forces caused by subsequent expansion. Contraction joints will be required transversely and may be required longitudinally depending upon slab thickness and spacing of construction joints. Contraction joints for reinforced and nonreinforced floor slabs are shown in figures 5-6 and 5-7, respectively. Instructions regarding the use of saw cuts or preformed inserts to form the weakened plane are contained in TM 5-822-7/ AFM 88-6, Chap. 8.



*d - IS DOWEL DIAMETER, FOR DOWEL SIZES AND SPACING SEE TABLE 5-3.
REINFORCEMENT IS NOT CARRIED THROUGH JOINT

a) REINFORCED

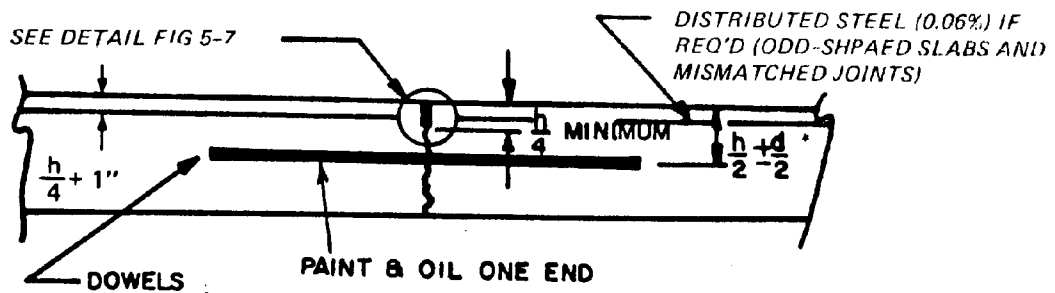

*d - DOWEL DIAMETER
FOR DOWEL SIZE AND SPACING SEE TABLE 5-3.

b) NONREINFORCED

Figure 5-6. Contraction joints for reinforced and nonreinforced floor slabs.

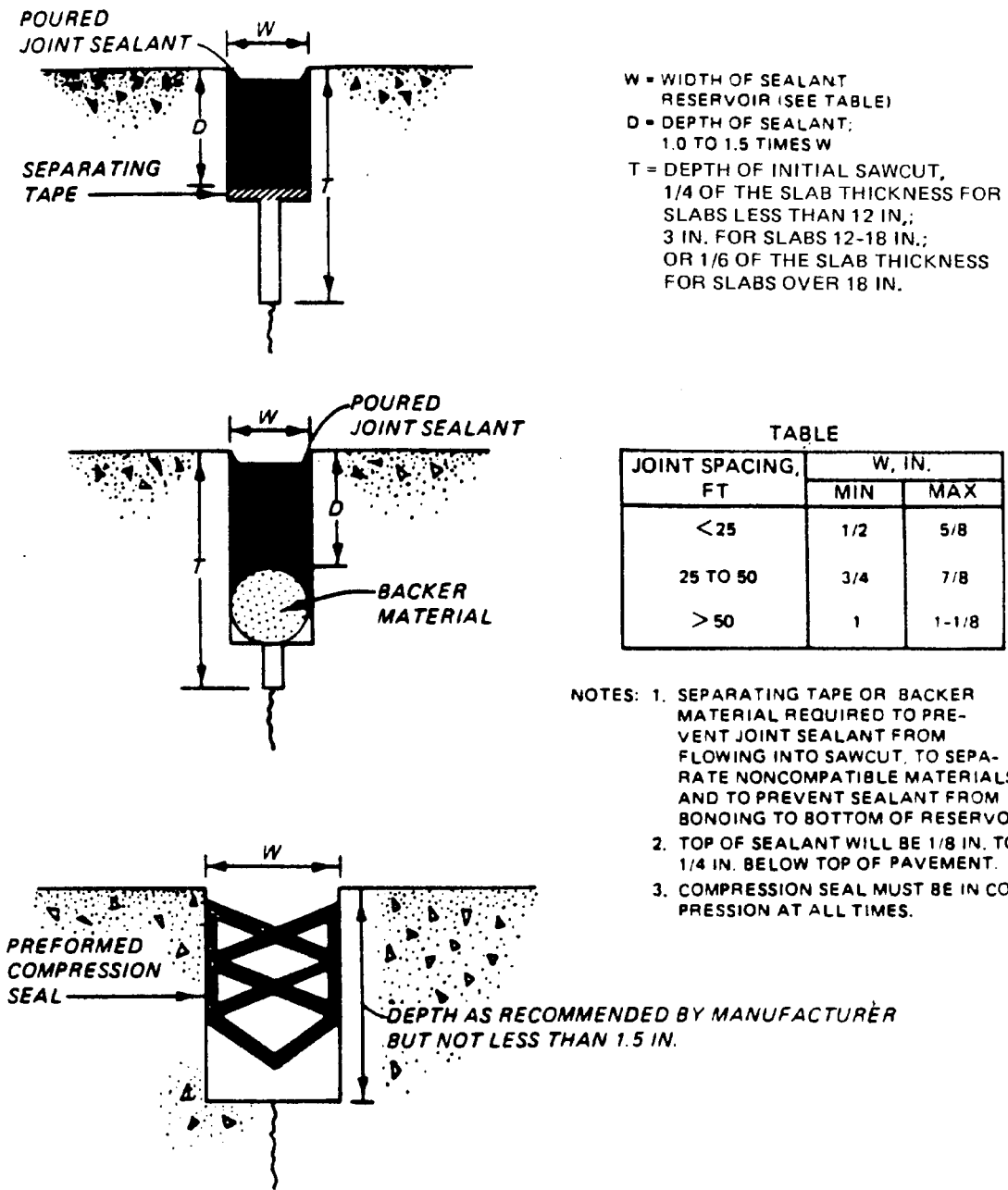

Figure 5-7. Joint sealant details.

(1) *Width and depth of weakened plane groove.* The width of the weakened plane groove will be a minimum of 1/8 inch and a maximum equal to the width of the sealant reservoir contained in (2) below. The depth of the weakened plane groove must be great enough to cause the concrete to crack under the tensile stresses resulting from the shrinkage and contraction of the concrete as it cures. Experience, supported by analyses, indicates that this depth should be at least one-fourth of the slab thickness for floor slabs 12 inches or less, 3 inches for pavements greater than 12 and less than 18 inches in thickness, and one-sixth of the slab thickness for floor slabs greater than 18 inches in thickness. In no case will the depth of the groove be less than the maximum nominal size of aggregate used. Sawcut contraction joints for steel-fiber reinforced concrete should be cut a minimum of one-third of the slab thickness. Concrete placement conditions may influence the fracturing of the

concrete and dictate the depth of groove required. For example, concrete placed early in the day, when the air temperature is rising, may experience expansion rather than contraction during the early life of the concrete with subsequent contraction occurring several hours later as the air temperature drops. The concrete may have attained sufficient strength before the contraction occurs so that each successive weakened plane does not result in fracturing of the concrete. As a result, excessive opening may result where fracturing does occur. To prevent this, the depth of the groove will be increased to assure the fracturing and proper functions of each of the scheduled joints.

(2) *Width and depth of sealant reservoir.* The width and depth of the sealant reservoir for the weakened plane groove will conform to dimensions shown in figure 5-8. The dimensions of the sealant reservoir are critical to satisfactory performance of the joint sealing materials.

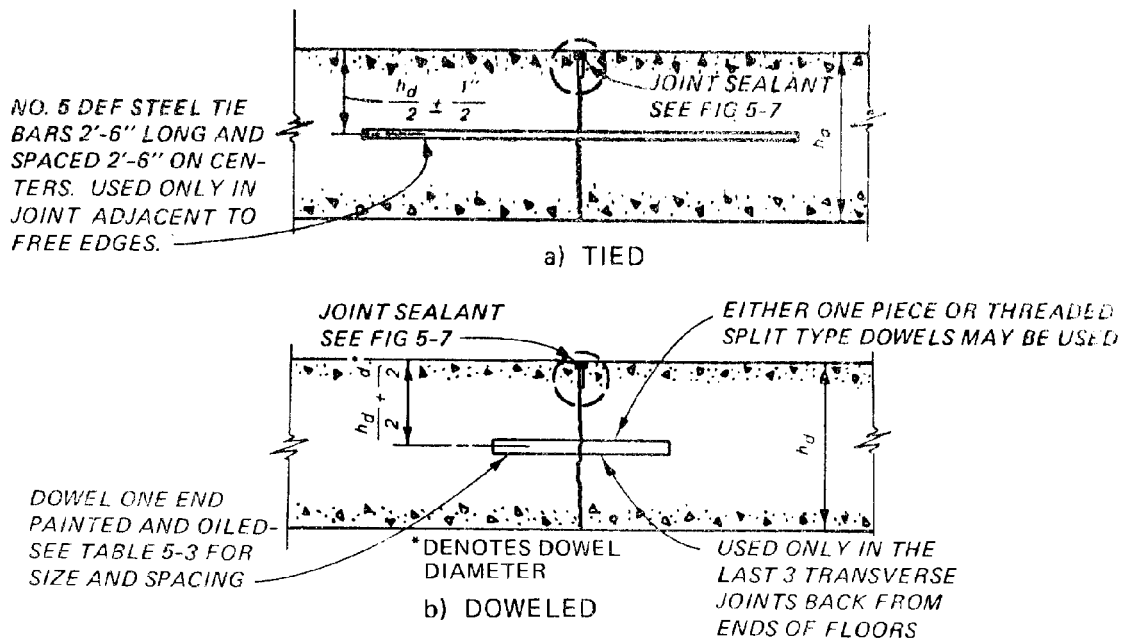

Figure 5-8. Contraction joint details.

(3) *Spacing of transverse contraction joints.* Transverse contraction joints will be constructed across each paving lane perpendicular to the center line. The joint spacing will be uniform throughout any major paved area, and each joint will be straight and continuous from edge to edge of the paving lane and across all paving lanes for the full width of the paved area. Staggering of joints in adjacent paving lanes can lead to sympathetic cracking and will not be permitted unless reinforcement, as described in paragraph 5-5*b*, is used. The maximum spacing of transverse joints that will effectively control cracking will vary appreciably depending on pavement thickness, thermal coefficient, and other characteristics of the aggregate and concrete, climatic conditions, and foundation restraint. It is impracticable to establish limits on joint spacing that are suitable for all conditions without making them unduly restrictive. For best slab performance, the number of joints should be kept to a minimum by using the greatest joint spacing that will satisfactorily control cracking. Experience has shown, however, that oblong slabs, especially in thin slabs, tend to crack into smaller slabs of nearly equal

dimensions under traffic. Therefore, it is desirable, insofar as practicable, to keep the length and width dimensions as nearly equal as possible. In no case should the length dimension (in the direction of paving) exceed the width dimension more than 25 percent.

(a) *Nonreinforced slabs.* The joint spacings in table 5-2 have given satisfactory control of transverse cracking in most instances and may be used as a guide, subject to modification based on available information regarding the performance of existing pavements in the vicinity or unusual properties of the concrete. The maximum size of a slab panel bounded by contraction joints should be 600 square feet in accordance with TM 5-809-2/AFM 88-3, Chap. 2. Under certain climatic conditions, joint spacings different from those in table 5-2 may be satisfactory. Where it is desired to change the joint spacing, a request will be submitted to HQDA (DAEN-ECE-G), Washington, DC 20314-1000, or Headquarters, Air Force Engineering Services Center (DEMP), Tyndall, AFB, Fla. 32403, outlining the local conditions that indicate that the proposed change in joint spacing is desirable.

Table 5-2. Recommended Spacing of Transverse Contraction Joints

Slab Thickness in.	Joint Spacing ft.
4 - 6*	Up to 12.5
6 - 9	12.5-15.0
9 - 12	15.0-20.0
> 12	20.0 - 25.0

*This thickness is allowed for steel-fiber reinforced concrete only.

(b) Reinforced slabs. Transverse contraction joints in reinforced concrete slabs should not be constructed at intervals of less than 25 feet nor more than 75 feet. Maximum allowable slab width and length may be determined from the equation

$$L = \sqrt[3]{0.00047 h_r (f_s S)^2} \leq 75 \quad (\text{eq 5-2})$$

where

- L = the maximum length (or width), feet
- h_r = the reinforced slab thickness, inches
- f_s = the steel yield strength, pounds per square inch
- S = steel reinforcing ration, percentage

Allowable slab dimensions can be determined directly from figure 5-4 for a yield strength of 60,000 pounds per square inch. Selection of final spacing should be based on local conditions. Where only a portion of the slabs are reinforced, joint spacing should be a maximum commensurate with the unreinforced slab configurations.

(4) *Spacing of longitudinal contraction joints.* Contraction joints will be placed along the centerline of paving lanes that have a width greater than the indicated maximum spacing of transverse contraction joints in table 5-2. These joints may also be required in the longitudinal direction for overlays, regardless of overlay thickness, to match joints existing in the base pavement unless a bond-breaking medium is used between the overlay and base slab or the overlay slab is reinforced.

(5) *Doweled and tied contraction joints.*

(a) Dowels are required in transverse contraction joints. Dowel requirements and specifications are given in paragraph 5-7d.

(b) For nonreinforced slabs, deformed tie bars, which are 5/8 inch in diameter, 30 inches long, and spaced on 30-inch centers, will be required in longitudinal contraction joints that fall 15 feet or less from the free edge of paved areas greater than 100 feet in width to prevent cumulative opening of these joints.

b. Construction joints. Construction joints are provided to separate areas of concrete placed at different times. They may be required in both the longitudinal and transverse directions. The spacing of construction joints will depend largely on the size and shape of the floor slab that is being placed and the equipment used to place it. Joint spacing will also be affected by column spacing and bay sizes. Longitudinal construction joints, generally spaced 20 to 25 feet apart but may reach 50 feet apart depending on construction equipment capability, will be provided to separate successively placed paving lanes. Transverse construction joints will be installed when it is necessary to stop concrete placement within a paving lane for a sufficient time for the concrete to start to set. All transverse construction joints will be located in place of other regularly spaced transverse joints (contraction or isolation types). There are several types of construction joints available for use, as shown in figures 5-9, 5-10, and 5-11 and as described below. The selection of the type of construction joint will depend on such factors as the concrete placement procedure (formed or slipformed) and foundation conditions.

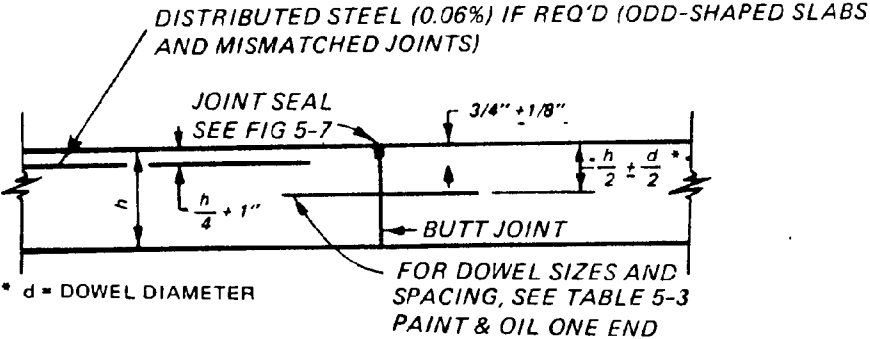

DETAIL A
NONREINFORCED

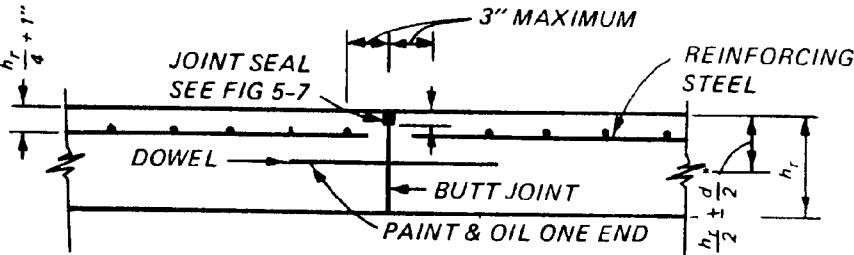

REINFORCING STEEL WILL NOT BE CARRIED THROUGH JOINT.
*d IS DOWEL DIAMETER, FOR DOWEL SIZES AND SPACING SEE TABLE 5-3
GROOVE MAY BE SAWED

DETAIL B
REINFORCED

Figure 5-9. Doweled construction joints for concrete floor slabs.

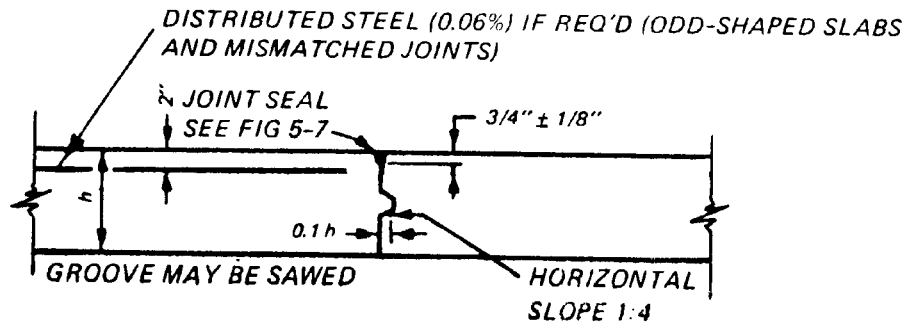

DETAIL A
NONREINFORCED

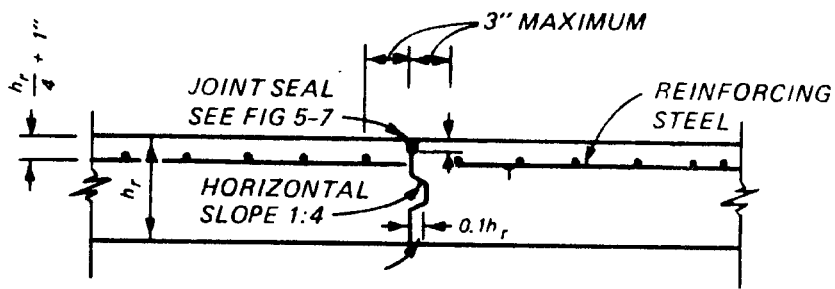

DETAIL B
REINFORCED

Figure 5-10. Keyed construction joints for concrete floor slabs.

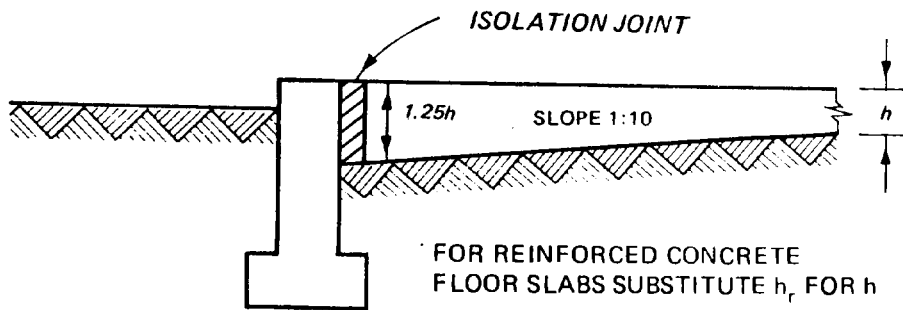

Figure 5-11. Doorway slab design for vehicular traffic.

(1) *Doweled butt joint.* The doweled butt joint is considered to be the best joint for providing load transfer and maintaining slab alignment. It is a desirable joint for the most adverse conditions such as heavy loading, high traffic intensity, and lower strength foundations. However, because the alignment and placement of the dowel bars are critical to satisfactory performance, this type of joint is difficult to construct, especially for slipformed concrete. However, the doweled butt joint is required for all transverse construction joints in nonreinforced pavements. Doweled construction joints are shown in figure 5-9.

(2) *Keyed joint.* The keyed joint is the most economical method, from a construction standpoint, of providing load transfer in the joint. It has been demonstrated that the key or keyway can be satisfactorily constructed using either formed or slipformed methods. Experience has proved that the required dimensions of the joint can best be maintained by forming or slipforming the keyway rather than the key. The dimensions and location of the key (fig 5-10) are critical to its performance. The structural adequacy of keyed construction joints in rigid floor slabs, however, can be impaired seriously by such factors as small changes in the dimensions of the key and positioning the key other than at the middepth of the slab. Exceeding the design values for the key dimensions produces an oversize key, which can result in failure of either the top or bottom edge of the female side of the joint. Similarly, construction of an undersize key can result in shearing off the key. Keyed joints should not be used in floor slabs 8 inches or less in thickness except where tie bars are used. Tie bars in the keyed joint, will limit opening of the joint and provide some shear transfer that will improve the performance of the keyed joints. However, tied joints in floor widths of more than 75 feet can result in excessive stresses and cracking in the concrete during contraction. When a longitudinal construction joint is used at the center of a floor two paving lanes wide, a keyed joint with tie bars should be used. When a keyed longitudinal structure joint is used at the center of a floor four or more paving lanes in width, dowels should be used.

(3) *Thickened-edge joint.* Thickened-edge-type joints may be used instead of other types of joints employing load-transfer devices. When the thickened-edge joint is constructed, the thickness of the concrete at the edge is increased to 125 percent of the design thickness. The thickness is then reduced by tapering from the free-edge thickness to the design thickness at a distance of 5 feet from the longitudinal edge. The thickened-edge butt joint is considered adequate for the load-induced concrete stresses. However, the inclusion of a key in the thickened-edge joint provides some degree of load transfer in the joint and helps maintain slab alignment; although not required, it is recommended for pavement constructed on low- to medium-strength foundations. The thickened-edge joint may be used at free edges of paved areas to accommodate future expansion of the facility or where wheel loadings may track the edge of the pavement. All floor slabs accommodating vehicular traffic will be thickened at doorways to have an edge thickness of 1.25 times the design thickness as shown in figure 5-11. The use of this type joint is contingent upon adequate base-course drainage.

c. *Isolation joints.* Isolation joints are provided to prevent load transfer and allow for differential settlement between the floor slab and other building components. Isolation joints also allow for some horizontal movement. Isolation joints should be placed at locations where slabs abut walls or their foundations and around columns, column foundations, and other foundations that carry permanent dead load other than stored material. Isolation joints are provided by placing 30-pounds asphalt, coal-tar saturated felt, or equivalent material between the floor slab and the building's structural components before the floor is placed. Such sheets should be placed or fastened to the building components to prevent any bonding or direct contact between the floor slab and the building component. This requires that the sheets have a height equal to the floor slab thickness and be placed at the same elevation as the floor slab, as shown in figure 5-12.

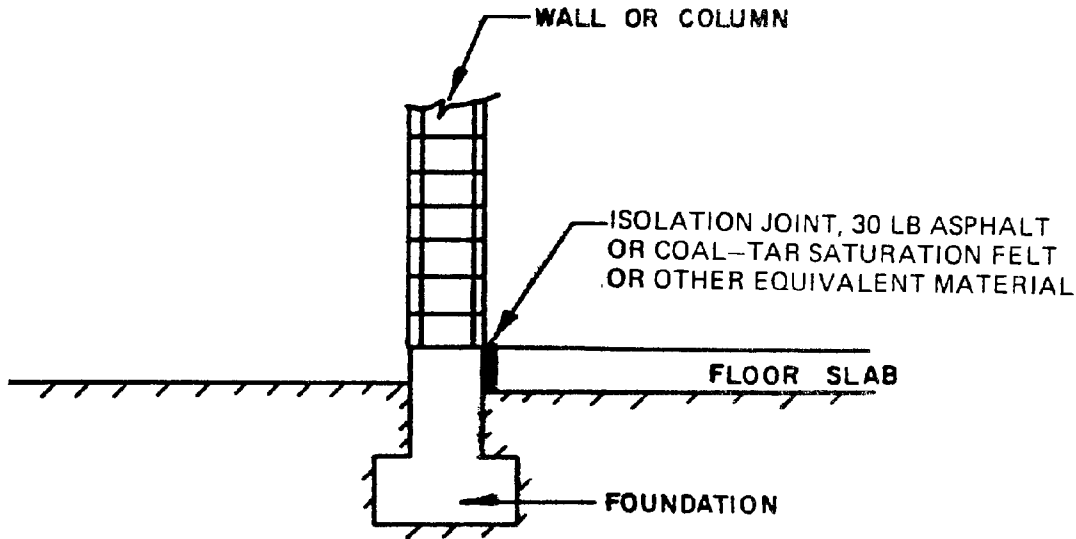

ISOLATION JOINTS MUST HAVE A HEIGHT EQUAL TO FLOOR SLAB THICKNESS

Figure 5-12. Isolation joints.

d. Special joints and junctures. Situations will develop where special joints or variations of the more standard type joints will be needed to accommodate the movements that will occur and to provide a satisfactory operational surface. Some of these special joints or junctures are discussed below.

(1) *Slip-type joints.* At the juncture of two pavement facilities, expansion and contraction of the concrete may result in movements that occur in different directions. Such movements may create detrimental stresses within the concrete unless provision is made to allow the movements to occur. At such junctures, a thickened-edge slip joint shall be used to permit the horizontal slippage to occur.

The design of the thickened-edge slip joint will be similar to the thickened-edge construction joint (fig 5-13). The bond-breaking medium will be either a heavy coating of bituminous material not less than 1/16 inch thick when joints match or a normal nonextruding-type expansion joint material not less than 1/4 inch thick when joints do not match. The 1/16-inch bituminous coating may be either a low penetration (60-70 grade asphalt) or a clay-type asphalt-base emulsion similar to that used for roof coating (Military Specification MIL-R-3472) and will be applied to the face of the joint by hand brushing or spraying.

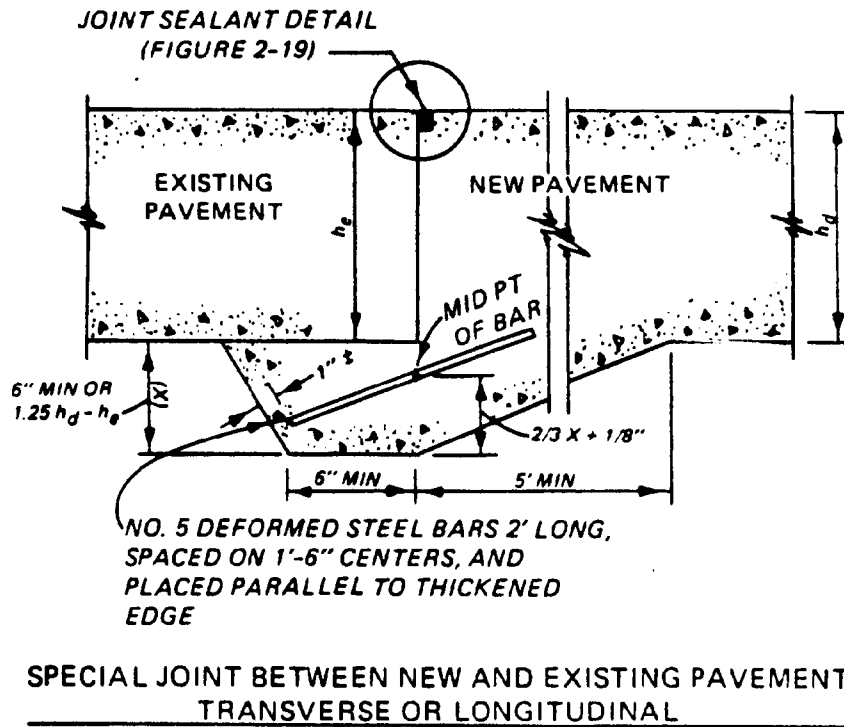
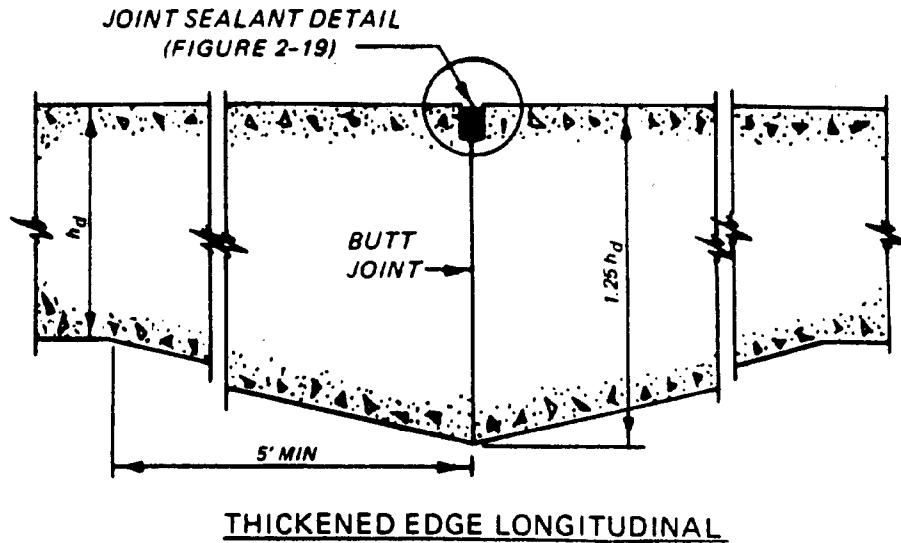

Figure 5-13. Thickened-edge joints.

(2) *Special joint between new and existing floors.* A special thickened-edge joint design (fig 5-13) will be used at the juncture of new and existing floors for the following conditions:

(a) When load-transfer devices (keyways or dowels) or a thickened edge was not provided at the free edge of the existing floor.

(b) When load-transfer devices or a thickened edge was provided at the free edge of the existing floor, but neither met the design requirements for the new floor.

(c) For transverse contraction joints, when removing and replacing slabs in an existing floor.

(d) For longitudinal construction joints, when removing and replacing slabs in an existing floor if the existing load-transfer devices are damaged during the slab removal.

(e) Any other location where it is necessary to provide load transfer for the existing floor. The special joint design may not be required if a new floor joins an existing floor that is grossly inadequate to carry the design load of the new floor, or if the existing floor is in poor structural condition. If the existing floor can carry a load that is 75 percent or less of the new floor design load, special efforts to provide edge support for the existing floor may be omitted; however, if omitted, accelerated failures in the existing floor may be experienced. Any load-transfer devices in the existing floor should be used at the juncture to provide as much support as possible to the existing floor. The new floor will simply be designed with a thickened edge at the juncture. Drilling and grouting dowels in the existing floor for edge support may be

considered as an alternate to the special joint; however, a thickened-edge design will be used for the new floor at the juncture.

e. Doweled joints. The primary function of dowels in floor slabs is that of a load-transfer device. As such, the dowels affect a reduction in the critical edge stress directly proportional to the degree of load transfer achieved at the joint. A secondary function of dowels is to maintain the vertical alignment of adjacent slabs, thereby preventing faulting at the joints. Dowels are required at all contraction joints in slabs that are 8 inches or greater in thickness and for thinner slabs in concentrated traffic areas.

(1) *Dowel specifications.* Dowel diameter, length, and spacing should be in accordance with the criteria presented in table 5-3. When dowels larger than 1 inch in diameter are required, an extra-strength pipe may be used as an alternate for solid bars. When an extra-strength pipe is used for dowels, however, the pipe should be filled with a stiff mixture of sand-asphalt or cement mortar, or the ends of the pipe should be plugged. If the ends of the pipe are plugged, plugs should fit inside the pipe and be cut off flush with the end of the pipe so that there will be no protruding material to bond with the concrete and prevent free movement of the pavement. All dowels should be straight, smooth, and free from burrs at the ends. One-half of each dowel should be painted and oiled or otherwise treated to prevent bonding with the concrete. A schematic drawing of joint layout showing dowels is given in figure 5-14.

Table 5-3. Dowel size and spacing

Pavement Thickness <u>inches</u>	Minimum Dowel Length <u>inches</u>	Maximum Dowel Spacing <u>inches</u>	<u>Dowel Diameter and Type</u>
Less than 8	16	12	3/4-inch bar
8 to and including 11.5	16	12	1-inch bar
12 to and including 15.5	20	15	1- to 1-1/4-inch bar, or 1-inch extra-strength pipe
16 to and including 20.5	20	18	1- to 1-1/2-inch bar, or 1- 1-1/2-inch extra-strength pipe
21 to and including 25.5	24	18	2-inch bar, or 2-inch extra- strength pipe
Over 26	30	18	3-inch bar, or 3-inch extra strength pipe

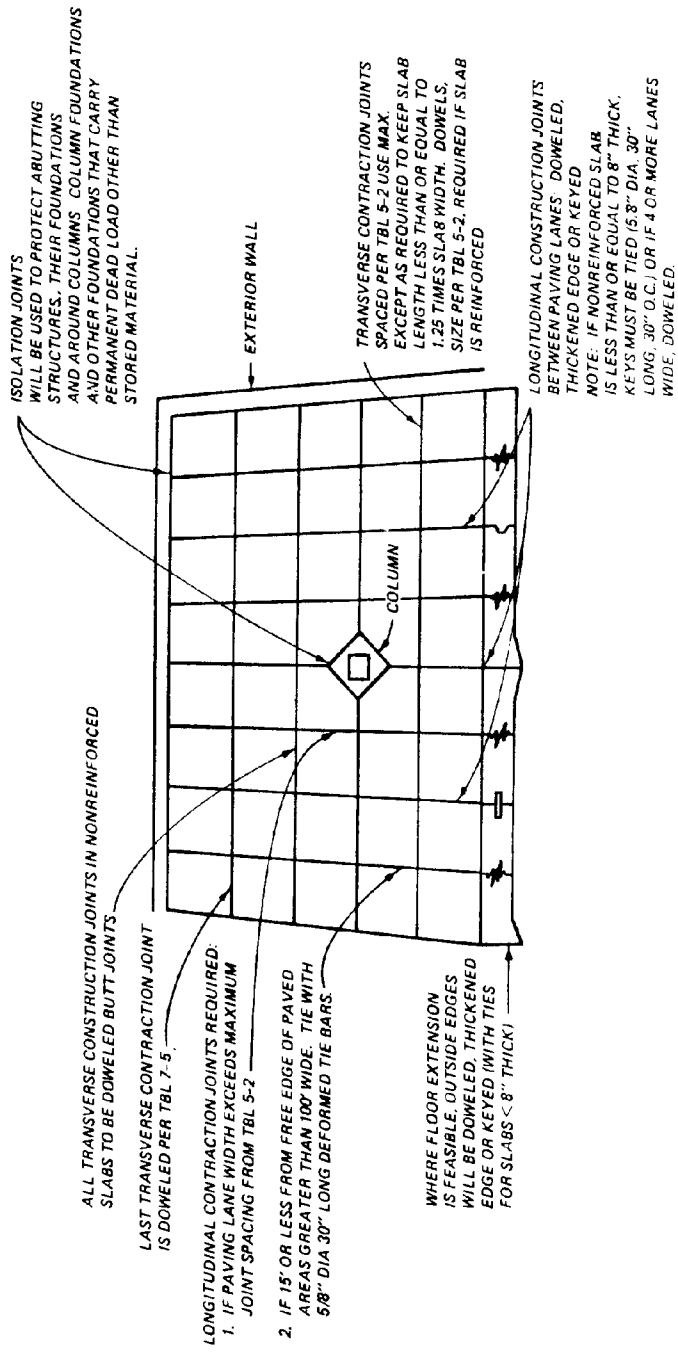

Figure 5-14. Joints in concrete floor slabs.

(2) *Dowel placements.* Normally, dowels should be located at the middepth of the floor slab. However, a tolerance of one-half of the dowel diameter, above or below middepth of the slab, may be allowed in locating the dowels in contraction and construction joints where the allowance of such a tolerance will expedite construction.

f. Joint sealing. All joints will be sealed with a suitable sealant to prevent infiltration of surface water and solid substances. A jet-fuel resistant (JFR) sealant will be used in the joints of floors where diesel fuel or other lubricants may be spilled during the operation, parking, maintenance, and servicing of vehicles. Sealants that are not fuel resistant will be used in joints of all other pavements. JFR sealants will conform to Federal Specifications SS-S-200 and SS-S-1614, and non-JFR sealants will conform to Federal Specifications 55-5-1401. Preformed sealants must have an uncompressed width of not less than twice the width of the joint sealant reservoir. The selection of a pourable or preformed sealant should be based upon the economics involved. Compression-type preformed sealants are recommended when the joint spacings exceed 25 feet and are required when joint spacings exceed 50 feet.

g. Special provisions for slipform paving. Provisions must be made for slipform pavers when there is a change in longitudinal joint configuration. The thickness may be varied without stopping the paving train, but the joint configuration cannot be varied without modifying the side forms, which will normally require stopping the paver and installing a header. The following requirements shall apply:

(1) The header may be set on either side of the transition slab with the transverse construction joint doweled as required. The dowel size and location in the transverse construction joint should be commensurate with the thickness of the pavement at the header.

(2) When there is a transition between a doweled longitudinal construction joint and a keyed longitudinal construction joint in the transition slab may be either keyed or doweled. The size and location of the dowels or keys in the transition slabs should be the same as those in the pavement with the doweled or keyed joint, respectively.

(3) When there is a transition between two keyed joints with different dimensions, the size and location of the key in the transition slab should be based on the thickness of the thinner pavement.

5-8. Floor slab geometry.

Careful attention should be given to floor-slab geometry to ensure proper drainage and satisfactory

operations. For proper drainage of the floor-slab surface into floor drains, a fall of $\frac{1}{4}$ inch per foot toward the floor drain is recommended. For sustained operations, gasoline- and LP gas-operated forklift trucks can generally negotiate a maximum slope of 20 percent (20 feet vertically for every 100 feet horizontally) satisfactorily. Electric-powered forklift trucks can perform sustained operations on a maximum slope of 10 percent (10 feet vertically for every 100 feet horizontally). The above-mentioned maximum slopes are based on a coefficient of friction of 0.9 for the operating surface. The use of sealants, waxes, etc., to reduce dusting will lower the coefficient of friction considerably. In areas where these compounds are used and a tough broom finish is not practical, reducing the slope of the ramp should be considered. If the slope cannot be reduced, pressure-sensitive abrasive tapes should be installed. The abrasive tapes are of the type used on stairway treads to produce a nonskid surface.

5-9. Fiber reinforced design.

a. Basis of jointed fiber reinforced concrete floor slab design. The design of jointed fiber concrete (JFC) floor slabs is based upon limiting the ratio of the concrete flexural strength and the maximum tensile stress at the joint, with the load either parallel or normal to the edge of the slab, to a value found to give satisfactory performance in full-scale accelerated test tracks. Because of the increased flexural strength and tenacity at cracks that develop in the fibrous concrete, the thickness can be significantly reduced; however, this results in a more flexible structure, which causes an increase in vertical deflections as well as in potential for densification and/or shear failures in the foundations, pumping of the subgrade material, and joint deterioration. To protect against these latter factors, a limiting vertical deflection criterion has been applied to the thickness developed from the tensile stress criteria.

b. Uses. Although several types of fiber have been studied for concrete reinforcement, most of the experience has been with steel fibers, and the design criteria presented herein are limited to steel fibrous concrete. Fibrous concrete is a relatively new material for pavement construction and lacks a long-time performance history. Because of this, its use will require approval of HQDA (DAEN-ECE-G), Washington, DC 20314-1 000, and/or Headquarters, Air Force Engineering Services Center (DEMP), Tyndall AFB, Fla. 32403. The major uses to date have been for thin resurfacing or strengthening overlays where grade problems restrict the thickness of overlay that can be used. The use of JFC floor slabs should be based upon the economics involved.

c. Mix proportioning considerations. The design mix proportioning of fibrous concrete will be determined by a laboratory study. The following are offered as guides and to establish limits where necessary for the use of the design criteria included herein.

(1) The criteria contained herein are based upon fibrous concrete containing 1 to 2 percent by volume (100 to 250 pounds) of steel fibers per cubic yard of concrete, and fiber contents within this range are recommended.

(2) Most experience to date has been with fibers from 1 to 1-1/2 inches long, and for use of the criteria contained herein, fiber lengths within this range are recommended.

(3) For proper mixing, the maximum aspect ratio (length to diameter or equivalent diameter) of the fibers should be about 100.

(4) The large surface area to volume ratio of the steel fibers requires an increase in the paste necessary to ensure that the fibers and aggregates are coated. To accomplish this, cement contents of 750 to 900 pounds per cubic yard of concrete are recommended. The cement content may be all portland cement or a combination of portland cement and up to 25 percent fly ash or other pozzolans.

(5) Maximum size coarse aggregates should fall between 3/8 and 3/4 inch. The percent of coarse aggregate (of the total aggregate content) can vary between 25 and 60 percent.

d. Thickness determination. The required thickness of FJC floor slabs will be a function of the design concrete flexural strength R , modulus of soil reaction k , the thickness h_b and flexural modulus of elasticity E_{fs} , of stabilized material if used, the vehicle or axle gross load, the volume of traffic, the type of traffic area, and the allowable vertical deflection. When stabilized material is not used, the required thickness h_{df} of JFC is determined directly from the appropriate chart (figs 5-15 and 5-16). If the base or subgrade is stabilized meets the minimum strength requirements of TM 5-822-4/AFM 88-7, Chap. 4, the stabilized layer will be treated as a low-strength base and the design will be made using the equation given in paragraph 5-2d(3) above. The resulting thickness, h or h_{dof} , will be rounded up to the nearest half or full inch. The rounded thickness, h_{df} or h_{dof} will then be checked for allowable deflection in accordance with paragraph 5-9e. The minimum thickness for JFC floor slabs will be 4 inches.

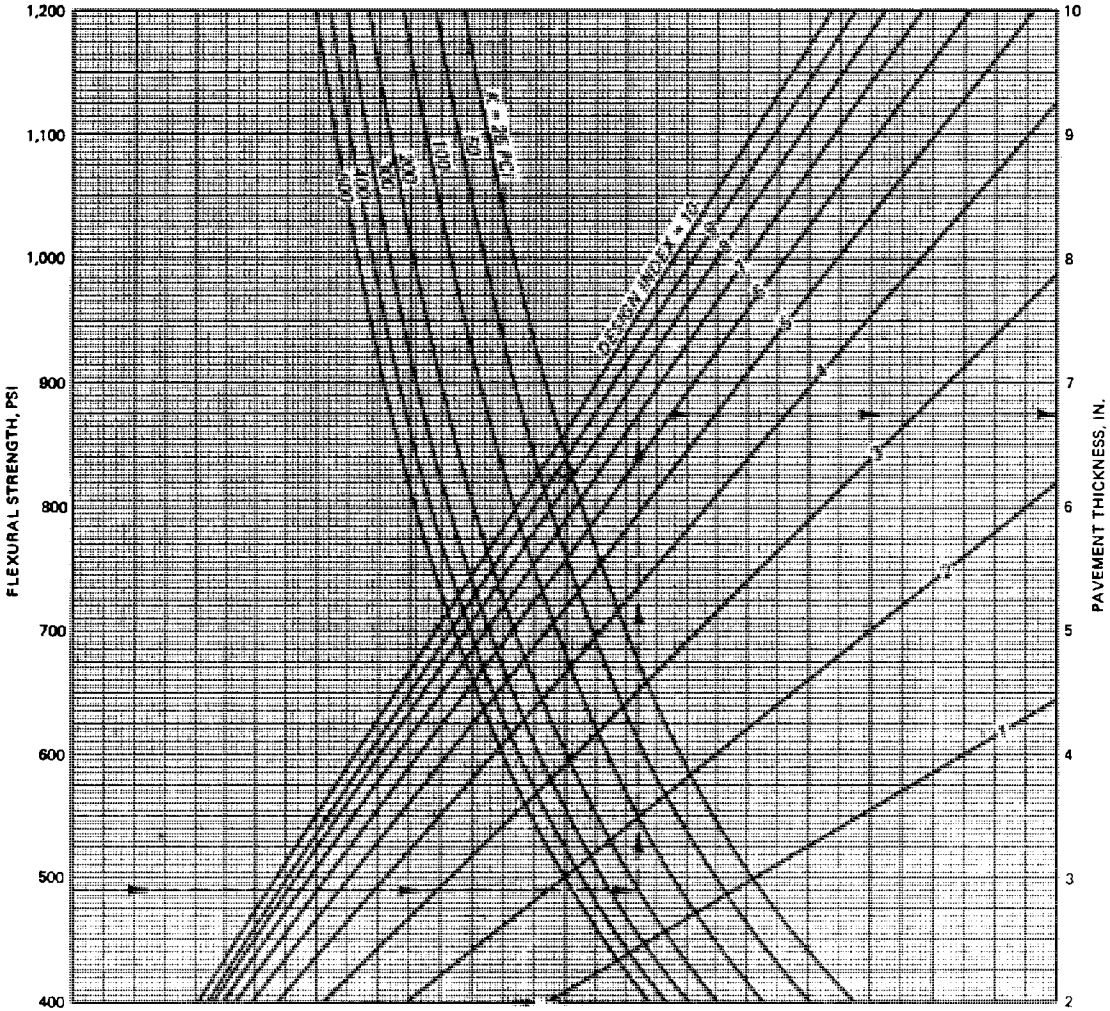

Figure 5-15. Design curves for fiber reinforced concrete floor slabs by design index.

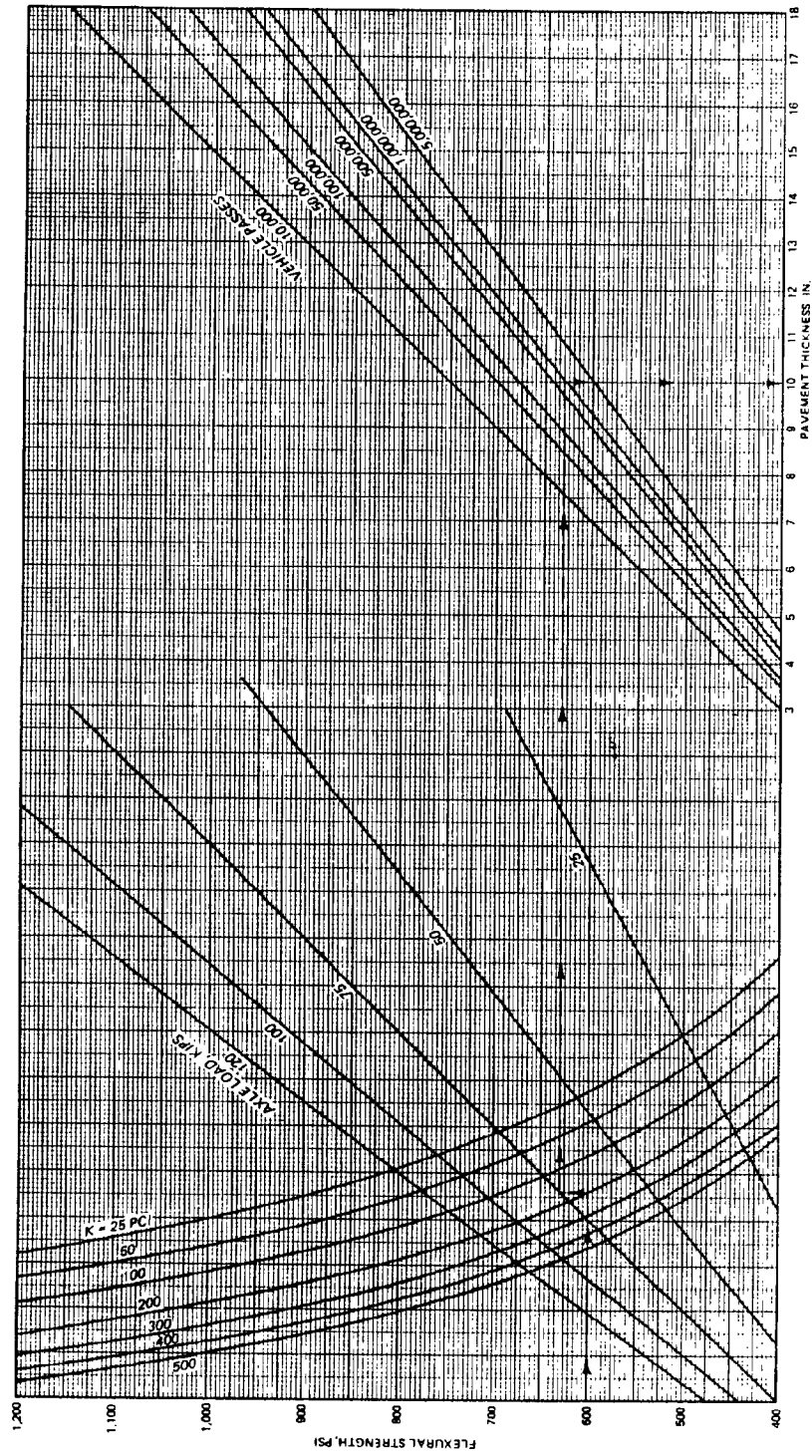

Figure 5-16. Design curves for fiber-reinforced concrete floor slab for heavy forklifts.

e. Allowable deflection for JFC pavement. The elastic deflection that JFC floor slabs experience must be limited to prevent overstressing of the foundation material and thus premature failure of the pavement. Curves are provided (fig 5-17) for the computation of the vertical elastic deflection that a slab will experience when loaded. Use of the curves requires three different inputs: slab thickness, subgrade modulus, and gross weight of the design vehicle. The slab thickness is that which is determined from paragraph 5-9*d* above. The computed vertical elastic deflection is then compared with appropriate

allowable deflections determined from figure 5-18. Deflections need not be checked for axle loads less than 25 kips. If the computed deflection is less than the allowable deflection, the thickness meets allowable deflection criteria and is acceptable. If the computed deflection is larger than the allowable deflection, the thickness must be increased or a new design initiated with a different value for either R or k . The process must be repeated until a thickness based upon the limiting stress criterion will also have a computed deflection equal to or less than the allowable value.

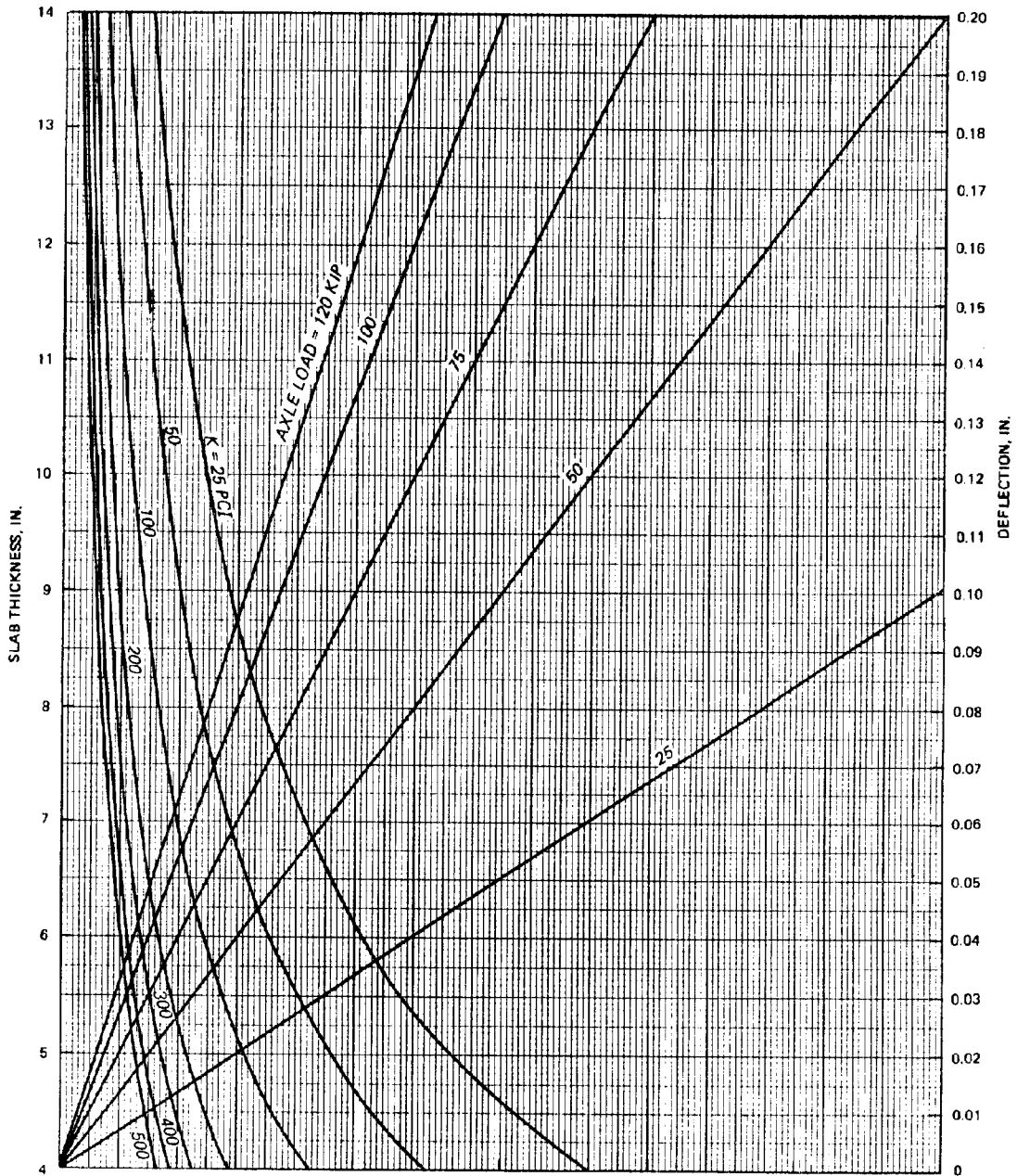

Figure 5-17. Deflection curves for fiber-reinforced concrete floor slabs.

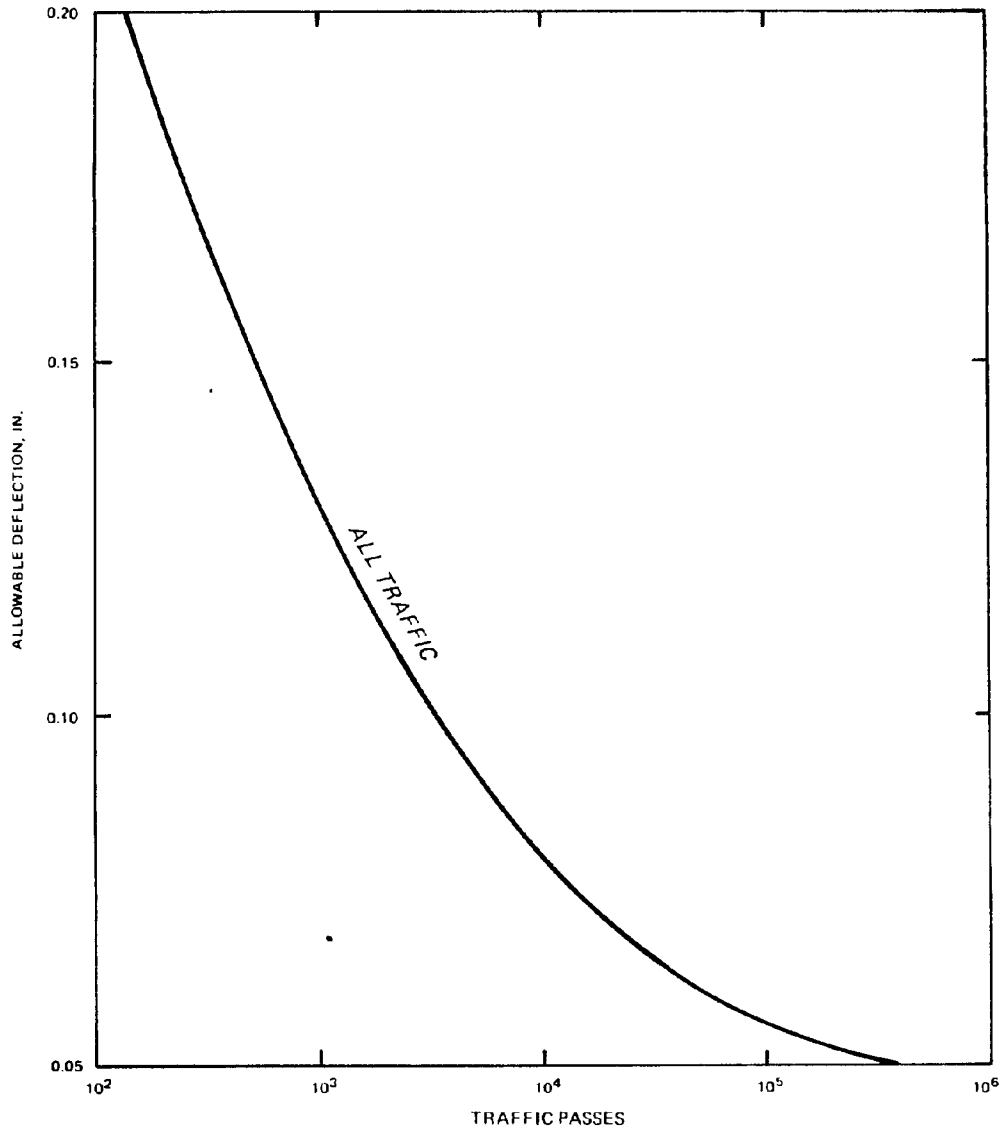

Figure 5-18. Allowable deflection for jointed fiber-reinforced concrete floor slabs.

APPENDIX A REFERENCES

Government Publications

General Services Administration

Federal Specifications

SS-S-200E	Sealing Compounds, Two-Component, Elastomeric, Polymer Type, Jet-Fuel-Resistant, Cold Applied.
SS-S-1401 C	Sealing Compound, Hot-Applied, for Concrete and Asphalt Pavements.
SS-S-1 614P	Sealing Compound, Jet-Fuel-Resistant, Hot Applied, One Component, for Portland Cement and Tar Concrete Pavements.

Department of Defense.

Military Standards

MIL-STD-619B	Unified Soil Classification System for Roads, Airfields, Embankments, and Foundations.
MIL-STD-621A & Notices 1 & 2	Test Method for Pavement Subgrade, Subbase, and Base-Course Materials

Military Specifications

MIL-R-3472	Roof-Coating, Asphalt-Base Emulsion.
------------	--------------------------------------

Departments of the Army and the Air Force.

TM 5-809-2/AFM 88-3, Chap. 2	Concrete Structural Design for Buildings.
TM 5-818-1/AFM 88-3, Chap. 7	<i>Soils and Geology</i> Procedures for Foundation Design of Buildings and Other Structures (Except Hydraulic Structures).
TM 5-818-2/AFM 88-6, Chap. 4	Pavement Design for Seasonal Frost Conditions.
TM 5-818-7	Foundations in Expansive Soil.
TM 5-822-4	Soil Stabilization for Pavements.
TM 5-822-6/AFM 88-7, Chap. 1	Engineering and Design: Rigid Pavements for Roads, Streets, Walks, and Open Storage Areas.
TM 5-822-7/AFM 88-6, Chap. 8	Standard Practice for Concrete Pavements.
TM 5-825-3/AFM 88-6, Chap. 3	Rigid Pavements for Airfields Other Than Army.
TM 5-825-2/AFM 88-6, Chap. 2	Flexible Pavement Design for Airfields.
TM 5-825-1/AFM 88-19, Chap. 1	Arctic and Subarctic Construction: General Provisions.
TM 5-825-4	Arctic and Subarctic Construction: Building Foundations.

TM 5-809-12/AFM 88-3, Chap. 15

TM-5-825-6/AFM 88-19, Chap. 6

Arctic and Subarctic Construction:
Calculation Methods for Determination of Depths of Freeze
and Thaw in Soils.

Non-government Publications

American Society for Testing and Materials (ASTM)
1916 Race St., Philadelphia, PA 19103

C 78

Standard Method of Test for Flexural Strength of Concrete
(using simple beam with Third-Point Loading).

APPENDIX B
EQUATIONS FOR COMPUTING THE ALLOWABLE WALL LOADS
NEAR CENTER OF SLAB OR NEAR KEYED
OR DOWELED JOINTS

$$P = 4\sigma_t S\lambda$$

$$\sigma_t = 1.6\sqrt{f'_c}$$

$$S = \frac{bt_e^2}{6}$$

$$\lambda = \sqrt[4]{\frac{12k}{4EI}}$$

$$E = 57,000 \sqrt{f'_c}$$

$$I = \frac{bt_e^3}{12}$$

$$b = 12 \text{ inches}$$

$$P = 4 \left(1.6 \sqrt{f'_c}\right) \left(\frac{bt_e^2}{6}\right) \sqrt[4]{\frac{12k}{4EI}}$$

$$= 4 \left(1.6 \sqrt{f'_c}\right) \left(\frac{12t_e^2}{6}\right) \sqrt[4]{\frac{3k}{57,000 \sqrt{f'_c} (12t_e^3/12)}}$$

$$P = 12.8 \sqrt{f'_c} t_e^2 \times \sqrt[4]{\frac{k}{19,000 \sqrt{f'_c} t_e^3}}$$

f'_c = specified compressive strength of concrete, pounds per square inch

t_e = slab thickness, inches

k = modulus of subgrade reaction, pounds per cubic inch

TM 5-809-12/AFM 88-3, Chap. 15

Equations for Computing the Allowable Wall Load Near A Free Edge

$$P = \frac{\sigma_t S \lambda}{B_{\lambda x}}$$

$B_{\lambda x} = 0.3224$ (point of maximum moment, see table in Beams on Elastic Foundations by M. Hetenyi)

$$P = 1.6 \sqrt{f'_c} \left(\frac{bt_e^2}{6} \right) \frac{\sqrt[4]{\frac{12k}{4EI}}}{0.3224}$$

$$= 1.6 \sqrt{f'_c} \left(\frac{12t_e^2}{6} \right) \frac{\sqrt[4]{\frac{3k}{57,000 \sqrt{f'_c} (12t_e^3/12)}}}{0.3224}$$

$$P = 9.93 \sqrt{f'_c} t_e^2 \sqrt[4]{\frac{k}{19,000 \sqrt{f'_c} t_e^3}}$$

APPENDIX C DESIGN EXAMPLES

C-1. Example 1: Concrete slab thickness for interior loads.

a. *Problem.* The floor slab for a warehouse will be designed based on the following information:

Traffic

<u>Type of Traffic</u>	<u>Average Daily Volume</u>	<u>Category</u>
5-axle trucks 4 axles, 5 kips each	50	I
1 axle, 10 kips 15-kip forklift or trucks	15	II
Stationary Live Load	1,200 pounds per square inch	
Interior Wall Load	1,400 pounds per linear foot	

Material properties

Concrete flexural strength = 650 pounds per square inch
 Modulus of subgrade reaction, k = 150 pounds per cubic inch

b. *Solution.*

(1) Floor slab thicknesses h should be determined by using equivalent forklift truck axle load below.

<u>Equivalent Forklift Truck Axle Load, kips</u>	<u>Number of Axles</u>	<u>Average Daily Volume</u>	<u>Maximum Operations Per Day</u>	<u>Design Index</u>
5	4	50	200	4
10	1	50	50	4
15	1	15	15	7

Matching the axle loads and maximum operations per day in table 5-1, the design index for each axle-load group is selected as shown in the far right column in the above-mentioned table. Design index 7 is selected for the design. From figure 5-1, using k = 150 pounds per cubic inch and 650 pounds per square inch flexural strength, slab thickness equal to 6.7 inches, and round to 7 inches should be selected.

(2) One must check for adequacy of 7 inch slab for stationary live load, w = 1 200 pounds per square foot. Table 3-1 should be entered using 650 pounds per square inch flexural strength concrete and 7 inch slab thickness; allowable stationary live load is selected, w =1,109 pounds per square inch. The w is adjusted based on k = 150 pounds per cubic inch.

$$w = 1,109 \sqrt{\frac{150}{100}} = 1,358\text{lb/ft}^2 > 1,200\text{lb/ft}^2$$

(3) Thickness, t_c, of thickened floor slab supporting interior wall weighing 1,400 pounds per linear foot should be determined by entering table 3-2 using 650 pounds per square inch flexural strength concrete and wall load p = 1,400 pounds per linear foot. Thus, t_c equals 10 inches, and t_c is adjusted based on k = 150 pounds per square inch.

$$t_c = 10 \sqrt[5]{\frac{100}{200}} = 9 \text{ inches}$$

from figure 3-1, minimum $t_c = h + h_1$; $t_c = 7 + 2 = 9$ inches.

C-2. Example 2: Thickened floor slab design for exterior wall.

a. *Problem.* The thickened concrete floor slab supporting an 8 inch exterior load bearing wall weighing 1,000 pounds per linear foot should be designed.

Floor slab data

- Thickness = 4 inches
- Flexural strength = 600 pounds per square inch
- Modulus of subgrade reaction $k = 200$ pounds per cubic inch

b. *Solution.* Table 3-3 should be entered using 600 pounds per square inch and wall load, $p = 1,000$ pounds per linear foot. Thickness t should be adjusted based on modulus of subgrade reaction, $k = 200$ pounds per cubic inch.

$$t_e = 10 \sqrt[5]{\frac{100}{200}} = 8.7$$

For thickened slab configuration, see table 3-3.

Note: For other practical considerations, i.e., frost line, erosion etc., the thickness, t_e , may be increased.

C-3. Example 3: Reinforced concrete slab.

a. *Problem.* It is decided that the 7-inch floor slab in Example 1 should be reduced to 6 inches by reinforcing the slab using 60,000-pounds per square inch yield strength steel reinforcement. The percent reinforcement required for the 6-inch slab should be determined.

b. *Solution.* From figure 5-4, a straight line should be drawn between $h = 7$ inches and $h_r = 6$ inches and extend line to S. This should read $S = 0.13$ percent.

C-4. Example 4: Concrete slab Thickness for tracked vehicle.

a. *Problem.* The floor slab thickness h , should be determined for a tank repair shop. The largest tank has a gross weight of 60 kips, Traffic is limited to 40 vehicles per day.

Material Properties:

- Concrete flexural strength = 700 pounds per square inch
- Modulus of subgrade reaction, $k = 100$ pounds per cubic inch

b. *Solution.* Based on 60 kips gross weight, equivalent forklift truck category II is selected from second tabulation in paragraph 3-2. From first tabulation in paragraph 3-2 for category II, forklift truck axle load is 10 to 15 kips. Table 5-1 is entered using 15 kips. Loaded at a frequency of 100 operation per day, the design index is 7. Figure 5-1 is entered using concrete flexure strength = 700 pounds per square inch, $k = 100$ pounds per cubic inch and $DI = 7$, slab thickness, $h = 6.6$ inches, or if rounded, 7 inches.

BIBLIOGRAPHY

- ASHRAE Handbook and Product Directory, 1981, Equipment, 1979, and Applications, 1982, American Society of Heating, Refrigerating, and Air Conditioning Engineers.
- Beams on Elastic Foundation, M. Hetenyi, University of Michigan Press, Ann Arbor, Mich., 1946.
- “Comparison of Splitting Tensile Strength of Concrete with Flexural and Compressive Strength,” W. W. Grieb and G. Werner, American Society for Testing and Materials, Proceedings, Vol 62, pp 972-995, 1962.
- Concrete Construction Handbook, J. W. Waddell, McGraw-Hill, New York, pp 6-12, 1968.
- “Concrete Strength Relationships,” G. M. Hammitt II, US Army Engineer Waterways Experiment Station, Miscellaneous Paper S-74-30, Vicksburg, Miss., 1974.
- “Criteria for Selection and Design of Residential Slabs-on-Ground.” National Academy of Sciences, Building Research Advisory Board, 1968.
- “Development of a Design Manual for Concrete Floor Slabs on Grade,” J. L. Rice, A. C. Eberhardt, and L. Varga, US Army Construction Engineering Research Laboratory, Technical Report S-27, 1974.
- “Minimum Concrete Strength for Pavements and Floor Slabs,” R. S. Rollings, US Army Engineer Waterways Experiment Station, Miscellaneous Paper GL-80-3, Vicksburg, Miss., 1980.
- “Partition Loads on Slabs-on-Grade,” E. Staab, US Army Engineer Missouri River Division, 1980.

By Order of the Secretaries of the Army and the Air Force:

CARL E. VUONO
General, United States Army
Chief of Staff

Official:

R. L. DILWORTH
Brigadier General, United States Army
The Adjutant General

LARRY D. WELCH, General, USAF
Chief of Staff

Official:

WILLIAM O. NATIONS, Colonel, USAF
Director of Information Management
and Administration

DISTRIBUTION:

Army:

To be distributed in accordance with DA Form 12-34B, Requirements for Concrete floors, Slabs on grade Subjected to Heavy Loads.

Air Force: F

