

FACILITIES CRITERIA (FC)
FACILITY PLANNING FOR NAVY AND
MARINE CORPS SHORE INSTALLATIONS

Series 100: OPERATIONAL AND TRAINING FACILITIES

Record of Changes:

Date	CCN #	CCN Title	Description of Change
08 May 2018	131	Command, Control, Communications, Computers, Combat Systems, Intelligence, Surveillance, And Reconnaissance (C5ISR) Buildings	Updated criteria to meet current mission requirements for Communications, Information, and Intelligence Facilities.
08 May 2018	131 15	Communications, Information, Or Intelligence Facility	Updated criteria to meet current mission requirements for Communications, Information, and Intelligence Facilities.
08 May 2018	131 17	Communications Station	CCN Deleted. Rolled into 131 15.
08 May 2018	131 24	Satellite Communications Facility	Updated criteria to reflect new 131 Introductory criteria.
08 May 2018	131 35	Receiver Building	Updated criteria to reflect new 131 Introductory criteria and eliminate references to CCNs that are being deleted.
08 May 2018	131 40	Telecommunications Distribution Facility	Updated criteria to reflect new 131 Introductory criteria.
08 May 2018	131 42	Automatic Communications Switching Center	Updated criteria reference for 131 40 to the new title name..
08 May 2018	131 50	Transmitter Building	Updated criteria to reflect new 131 Introductory criteria.
08 May 2018	131 60	Military Affiliate Radio Station (Mars	Updated criteria to indicate use for "inventory purposes only" until the CCN is absorbed or eliminated.
08 May 2018	131 65	Communications Analysis Facility	CCN Deleted. Rolled into 131 15.
08 May 2018	137 10	Meteorology And Oceanography Building	CCN Deleted. Rolled into 131 15.
08 May 2018	143 40	Computer Programming Operations Center	CCN Deleted. Rolled into 131 15.
08 May 2018	143 65	Region / Installation Emergency Operations Center	Updated criteria to reflect new 131 Introductory criteria.

Date	CCN #	CCN Title	Description of Change
08 May 2018	143 80	Mission Operation Command And Control Facility	Updated criteria to reflect new 131 Introductory criteria.
08 May 2018	C5ISR	Command, Control, Communications, Computers, Combat Systems, Intelligence, Surveillance, And Reconnaissance (C5ISR) Facilities	A C5ISR BFR Calculator is available on the NAVFAC Portal to be used in tandem with the updated C5ISR Planning Criteria. Use the portal search function to search for "C5ISR BFR Calculator".
13 June 2018	125 20	Shed/Shelter For Pump Station And Ancillary Equipment	Remapped to FAC 1459 as per OSD/RPCP FY18.
13 June 2018	143 09	Expeditionary Ops Support Facility	Changed title from "Expeditionary Ops Support Module" to "Expeditionary Ops Support Facility" as per OSD/RPCP FY18.
13 June 2018	171 21	Decontamination Training Facility	CCN deleted. Not a standalone facility.
24 Oct 2018	143 80	Mission Operation Command And Control Facility	Minor change to language in section 14380-2.
11 June 2019	171 30	Physical Education Building	Minor editorial change to paragraph numbering
12 July 2019	143 12	Operational Storage Laydown	Updated table 14312-1 and 14312-2 and added verbiage
08 Aug 2019	116 55	Tactical Support Laydown Area	Changed Title from "Ordnance Handling Pad" to "Tactical Support Laydown Area"
08 Aug 2019	121 20	Aircraft Truck Fueling Facility	Remapped to FAC 1261.
08 Aug 2019	122 30	Small Craft Ready Fuel Storage	Remapped to FAC 1242.
08 Aug 2019	179 09	Ship Loading and Unloading Mockup	Remapped to FAC 1732. Changed UM to SF
08 Aug 2019	179 11	Air Transport Mockup	Remapped to FAC 8526. Changed UM to SY
08 Aug 2019	179 12	Elevated Training Tower/Platform	Changed Title from "Parachute Landing Fall Platform" to "Elevated Training Tower/Platform". Remapped to FAC 1734.
08 Aug 2019	179 13	Suspended Harness Mockup	CCN Deleted in FY19. Assets have been consolidated into CCN 179 12
08 Aug 2019	179 14	Mockup Jump Tower	CCN Deleted in FY19. Assets have been consolidated into CCN 179 12

Date	CCN #	CCN Title	Description of Change
08 Aug 2019	179 15	Underwater Fording Site	CCN Deleted in FY19.
08 Aug 2019	179 18	Airfield Demolition Range (ADR)	Changed Title from "Road/Airfield Construction Training Site" to "Airfield Demolition Range"
24 Sep 2019	111 30	Runway Overrun-Paved Surface	Revised Table 11130-1 for longitudinal centerline grade, Class A Runway to match recent update of UFC 3-260-01.
24 Sep 2019	141 82	Full Pressure Suit Facility	Revised text to indicate pressure suit maintenance is normally performed in the Aviation Life Support Systems Shop (Non-Navair Depot), Category Code 211 75.
03 August 2020	116 41	Improved Fresnel Lens Optical Landing System (IFLOLS) Pad	CCN added.
03 August 2020	143 08	Expeditionary Ops Boat Maintenance Repair Facility	CCN added.
03 August 2020	143 13	Operational Vehicle/Equipment Canopy	CCN added.
03 August 2020	144 40	Scale House	CCN added.
03 August 2020	148 10	Ship Propulsion Support Facility	Retitled and changed description to remove the term "nuclear".
03 August 2020	148 15	Ship Weapons Handling Facility	Retitled and changed description to remove the term "nuclear".
03 August 2020	148 20	Ordnance Demolition Area	CCN deleted but see note under 148 20.
03 August 2020	148 25	Explosive Truck Holding Yard	Remapped to FAC 8526. UM changed to SY.
03 August 2020	148 35	Container Holding Yard	Remapped to FAC 8526. UM changed to SY.
03 August 2020	148 40	Container Transfer Facility (Ordnance)	Remapped to FAC 8526. UM changed to SY.
03 August 2020	148 45	Rail/Truck Receiving Station (Ordnance)	Remapped to FAC 8526. UM changed to SY.

Date	CCN #	CCN Title	Description of Change
03 August 2020	149 20	Aircraft Catapult	CCN deleted but see note under 149 20.
03 August 2020	149 62	Tactical Vehicle Wash Facility	CCN added.
03 August 2020	153 10	Cargo Staging Area	Remapped to FAC 8526.
03 August 2020	179 21	Armored Vehicle Launch Bridge, Raft, and Ford Area	CCN deleted.
03 August 2020	179 53	Enclosed Fire Fighter Trainer Facility	CCN added.
01 April 2021	151 Section 151-1	Pier Facilities	Delete reference to 165-10. Add reference to UFC 4-150-06, Military Harbors and Coastal Facilities
01 April 2021	151 Section 151-4	Pier Facilities	Add complete title, Military Harbor and Coastal Facilities for UFC 4-150-06.
20 Jan 2023	143-11	Operational Vehicle Garage	<ol style="list-style-type: none"> Expand the "Definition" information. Include additional guidance for calculating the space requirements. Add new tables with space requirements.
20 Jan 2023	143-12	Operational Vehicle Parking/Laydown Area	Change Net to Gross factors for Table 14312-1 and added 1B designation to Table 14312-2.
20 Jan 2023	143-22	Navy Explosive Ordnance Disposal Shore Detachment Facility	Redefine EOD Shore DET Facility.
20 Jan 2023	149-10	Protective Barricades	Redefine Protective Barricade/Revetment to support explosives safety requirements.
20 Jan 2023	148-20	Ordnance Demolition Area	CCN was deleted in Aug 2020 but is reinstated and will be remapped to FAC Code 1783 in FY23.
20 Jan 2023	173-40	Observation Tower/Bunker	CCN added to serve as a protective shelter facility at ranges for personnel protection.
2 Mar 2023	100 Series	UFC 2-000-05N	Change UFC 2-000-05N to FC 2-000-05N document due to the fact that this planning criteria is not unified among the other DoD services.
17 Mar 2023	141-20	Aircraft Fire and Rescue Station	Change URL to access Space Planning Spreadsheet. Change URL to access Design UFC 4-730-10 Fire Stations.
17 Mar 2023	151 Series, 151-5	Pier Facilities	Change URL to access Design UFC 4-150-06 Military Harbors and Coastal Facilities.

Date	CCN #	CCN Title	Description of Change
17 Mar 2023	171-15, Section 17115-3.2	Navy and Marine Corps Reserve Training	Change URL to access NOSC Space Planning Spreadsheet. Change URL to access Design Criteria FC 4-171-06N Navy Operational Support Center.
31 Mar 2023	123-30, Section 12330-7	Vehicle and Equipment Ready Fuel Storage	Replace reference CCN 126-50 with CCN 126-15 Petroleum Ready Fuel Storage Facility.
31 Mar 2023	156-10, Section 15610-1	Waterfront Transit Shed	Include reference to Section 440-2 General Supply Requirements in Category Code 440 Series.
11 Jul 2023	126-15	Petroleum Ready Fuel Storage Facility	Change the Unit of Measure (UM) from BL to GA.
30 Aug 2023	131-12 131-13 131-17 135-11 135-12 135-13 135-15 135-21 135-31 135-32 135-33	Communications Maintenance Vault Communications Maintenance Tunnel Communications Maintenance Channel Fiber Optic Communications Lines, Underground in Conduit Fiber Optic Communications Lines, Non-Conductive Riser Rated Fiber Optic Communications Lines, Outside Plant, Armored Optical Ground Wire Fiber Optic Communications Lines, Outside Plant, Marinized (Underwater/Wetland) Copper Communications Lines, Outside Plant, Gel Filled Copper Communications Lines, Outside Plant, Air Core Copper Communications Lines, Outside Plant, Marinized (Underwater/Wetland)	Category Code changes included with updated descriptions / definitions for all CCNs listed.

Date	CCN #	CCN Title	Description of Change
	135-34	Copper Communications Lines, Outside Plant, Armored	
	179-17	Rappelling Training Area	
	179-24	Water Supply Training Area	
	143-10	Emergency Vehicle Garage	
30 Aug 2023	111-12	Runway / Fixed Wing – Unsurfaced	New Category Code information clarified
	179-51	Unenclosed Fire Fighter Trainer	For CCNs 179-51, 179-54, and 179-54, new information included to clarify the distinction between the various types of trainers.
	179-53	Enclosed Fire Fighter Facility	
	179-54	Damage Control (Wet) Trainer	
14 Dec 2023	143 75	POL Operations/Sampling/Testing Building	Change 162.5 NSF to 162-5 GSF. Change sentence that illustrates “net area” to “gross area.” In sentence that illustrates “gross to net multiplier,” change to “net-to-gross multiplier.”
4 Apr 2024	143 26	Marine Corps Explosive Ordnance Disposal Company Facility	Develop update planning criteria to support changes to Marine Corps EOD operations.
4 Apr 2024	171 50	Small Arms Range - Indoors	Change design UFC reference in Section 17150-3 to UFC 4-179-02.
4 Apr 2024	122 20	Small Craft Fueling Station	In Section 12220-3, delete reference to CCN Series 124 and replace with “See Category Code 122 30 for additional fuel storage information.”

100 SERIES OPERATIONAL AND TRAINING FACILITIES

Table of Contents

110	AIRFIELD PAVEMENTS	19
110-1	PAVEMENTS	19
110-2	CLASS A AND B RUNWAY CRITERIA	19
111	AIRFIELD PAVEMENTS - RUNWAYS.....	23
111 10	RUNWAY/FIXED WING (M2/SY)	23
111 12	RUNWAY/FIXED WING - UNSURFACED (M2/SY)	33
111 15	RUNWAY/ROTARY WING (M2/SY).....	33
111 20	HELICOPTER LANDING PAD/HOVERPOINT (M2/SY).....	35
111 25	FIXED WING AIRCRAFT (VTOL) LANDING PAD	36
111 30	RUNWAY OVERRUN-PAVED SURFACE (M2/SY)	37
112	AIRFIELD PAVEMENTS – TAXIWAYS.....	38
112 10	TAXIWAY (M2/SY)	38
113	AIRFIELD PAVEMENTS – APRONS (INCLUDES AIRCRAFT PARKING AND ACCESS APRONS).....	40
113 20	AIRCRAFT PARKING APRON (M2/SY), Revised Nov 2011.....	40
113 40	AIRCRAFT ACCESS APRON (M2/SY)	52
116	AIRCRAFT PAVEMENTS – OTHER.....	52
116 10	AIRCRAFT WASHRACK PAVEMENT (M2/SY)	52
116 12	AIRCRAFT PAVEMENT SHOULDER (M2/SY).....	54
116 15	AIRCRAFT RINSE FACILITY (M2/SY).....	54
116 20	AIRCRAFT COMPASS CALIBRATION PAD (M2/SY)	55
116 35	ARMING AND DE-ARMING PAD (M2/SY).....	56
116 40	PRECISION APPROACH RADAR (PAR) PAD (M2/SY)	57
116 41	PRECISION APPROACH RADAR (PAR) PAD (M2/SY).....	57
116 42	BLAST PROTECTIVE PAVEMENT (M2/SY).....	57
116 45	LINE VEHICLE PARKING (M2/SY).....	58
116 50	TOWWAY (M2/SY).....	59
116 55	ORDNANCE HANDLING PAD (M2/SY).....	59
116 56	COMBAT AIRCRAFT LOADING AREA (CALA) (M2/SY).....	62
116 60	FIRE AND RESCUE VEHICLE ALERT PAD (M2/SY).....	63
116 65	TACTICAL SUPPORT VAN PAD (M2/SY)	64
121	AVIATION FUEL FACILITIES.....	71

121 10	AIRCRAFT DIRECT FUELING STATION (GM)	71
121 20	AIRCRAFT TRUCK FUELING FACILITY (GM)	72
121 30	AIRCRAFT DEFUELING FACILITY (GM)	74
121 50	AIRCRAFT READY FUELS STORAGE (BL).....	74
122	MARINE FUEL FACILITIES	75
122 10	MARINE FUELING FACILITY (GM)	75
122 20	SMALL CRAFT FUELING STATION (GM).....	76
122 30	SMALL CRAFT READY FUEL STORAGE (GA)	76
123	LAND/GROUND VEHICLE FUELING/DISPENSING FACILITIES	77
123 10	FILLING STATION (OL)	77
123 15	FILLING STATION BUILDING (SF).....	78
123 16	OVERHEAD COVER, AIRFIELD (SF).....	78
123 17	OVERHEAD COVER, MISCELLANEOUS (SF)	78
123 30	VEHICLE AND EQUIPMENT READY FUEL STORAGE (GA).....	79
123 40	ETHANOL READY FUEL STORAGE (GA)	79
123 50	BIODIESEL READY FUEL STORAGE (GA)	80
125	POL DISTRIBUTION / PIPELINE FACILITIES.....	80
125 10	POL PIPELINE (MI).....	80
125 16	POL PIPELINE PUMP STATION AND ANCILLARY EQUIPMENT (EA)...	81
125 20	SHED/SHELTER FOR PUMP STATION AND ANCILLARY EQUIPMENT (SF)	81
125 21	POL Piping-Single Site (LF).....	81
125 30	SURGE STORAGE (GA).....	81
126	OTHER LIQUID PETROLEUM PRODUCTS FACILITIES.....	81
126 10	DRUM AND CAN LOADING FACILITY (SF).....	82
126 15	PETROLEUM READY FUEL STORAGE FACILITY (GA)	82
126 30	TANK TRUCK TANK CAR LOADING FACILITY (OL).....	83
126 40	TANK TRUCK/TANK CAR UNLOADING FACILITY (OL).....	84
131	COMMAND, CONTROL, COMMUNICATIONS, COMPUTERS, COMBAT SYSTEMS, INTELLIGENCE, SURVEILLANCE, AND RECONNAISSANCE (C5ISR) BUILDINGS	85
131 10	CABLE HOUSE (SF).....	106
131 12	COMMUNICATIONS MAINTENANCE VAULT (EA)	106
FAC: 8927	106
BFR Required: N	106
131 13	COMMUNICATIONS MAINTENANCE TUNNEL (LF)	106

FAC: 8931	106
BFR Required: N	106
131 15 COMMUNICATIONS, INFORMATION, OR INTELLIGENCE FACILITY (SF)	106
131 17 COMMUNICATIONS MAINTENANCE CHANNEL (LF).....	111
131 20 COMMUNICATIONS RELAY FACILITY (SF).....	111
131 22 VHF/UHF COMMUNICATIONS FACILITY (SF).....	111
131 24 SATELLITE COMMUNICATIONS FACILITY (SF).....	112
131 25 TELEMETRY BUILDING (SF)	115
131 30 HELIX HOUSE (SF)	115
131 35 RECEIVER BUILDING (SF)	115
131 40 TELECOMMUNICATIONS DISTRIBUTION FACILITY (SF)	119
131 42 AUTOMATIC COMMUNICATIONS SWITCHING CENTER (SF).....	122
131 45 TERMINAL EQUIPMENT BUILDING (SF)	122
131 50 TRANSMITTER BUILDING (SF).....	122
131 55 CIRCULARLY DISPOSED ANTENNA ARRAY BUILDING (SF).....	126
131 56 DIRECTION FINDER BUILDING (SF).....	126
131 60 MILITARY AFFILIATE RADIO STATION (MARS) (SF).....	126
131 65 COMMUNICATIONS ANALYSIS FACILITY (SF) [delete]	127
132 COMMUNICATIONS-OTHER THAN BUILDINGS	127
132 10 ANTENNA-COMMUNICATIONS (EA).....	127
132 50 PUBLIC ADDRESS SYSTEM - OUTDOOR (EA).....	128
132 55 CIRCULARLY DISPOSED ANTENNA ARRAY (WULLENWEBER) (EA)	128
133 NAVIGATION AND TRAFFIC AIDS – BUILDINGS (NON-SHIP RELATED)	129
133 15 RADAR WIND SOUNDING (RAWIN) BUILDING	134
133 20 VERY HIGH FREQUENCY (VHF) OMNI-DIRECTIONAL RANGE (VOR) FACILITY (M2/SF).....	134
133 25 TACTICAL AIR NAVIGATION (TACAN) BUILDING (M2/SF).....	134
133 30 VERY HIGH FREQUENCY (VHF) OMNI-DIRECTIONAL RANGE/TACTICAL AIR NAVIGATION (VORTAC) BUILDING (M2/SF) .	135
133 35 NON-DIRECTIONAL BEACON (NDB) FACILITY (M2/SF).....	136
133 65 AIR NAVIGATION BUILDING (M2/SF).....	136
133 71 RADAR AIR TRAFFIC CONTROL FACILITY (RATCF) (M2/SF).....	137
133 72 MILITARY TERMINAL RADAR APPROACH CONTROL FACILITY (MTRACON) (FORMERLY RATCC CENTER) (M2/SF).....	138
133 73 FLEET AREA CONTROL SURVEILLANCE FACILITY (M2/SF)	139

133 74	JOINT CONTROL FACILITY (M2/SF)	141
133 75	AIR SURVEILLANCE RADAR (ASR) FACILITY (M2/SF).....	142
133 76	AIR ROUTE SURVEILLANCE RADAR (ARSR) FACILITY (M2/SF)	142
133 80	WHEELS WATCH SHELTER (EA).....	143
134	NAVIGATION AND TRAFFIC AIDS - OTHER (NON - SHIP RELATED)	143
134 10	ANTENNA - NAVIGATION (EA)	143
134 20	AIRPORT AND/OR HELIPORT BEACON (EA).....	144
134 40	GROUND CONTROL APPROACH SYSTEM (EA)	145
134 41	PRECISION APPROACH RADAR (PAR) (EA)	145
134 42	PRECISION APPROACH LANDING SYSTEM (PALS) (EA).....	146
134 43	INSTRUMENT LANDING SYSTEM (ILS) (EA).....	146
134 44	MICROWAVE LANDING SYSTEM (MLS) (EA).....	147
134 45	SHORE BASED AUTOMATIC CARRIER LANDING SYSTEM (ACLS) (EA)	147
134 50	OBSTRUCTION LIGHTING AND MARKINGS (EA).....	148
134 55	VISUAL APPROACH SLOPE INDICATOR (VASI) SYSTEM (EA).....	149
134 56	PRECISION APPROACH PATH INDICATOR (PAPI) SYSTEM (EA)	151
134 60	OPTICAL LANDING AIDS (EA).....	153
134 62	WIND DIRECTION INDICATOR (EA).....	156
134 64	RUNWAY DISTANCE MARKERS (EA).....	157
134 66	VOR/TACAN CHECK SIGN (EA)	158
134 70	RADAR TOWER (EA).....	159
134 71	AVIATION METEOROLOGICAL FACILITY (EA)	159
135	COMMUNICATION LINES	159
135 10	COMMUNICATION LINES OTHER THAN TELEPHONE (MI).....	159
135 11	Fiber optic communications lines, underground	160
135 12	FIBER OPTIC communications lines, Non-Conductive Riser Rated (EA)	160
135 13	FIBER OPTIC COMMUNICATIONS LINES, OUTSIDE PLANT,	160
	ARMORED (MI).....	160
135 15	OPTICAL GROUND WIRE (MI)	160
135 20	TELEPHONE LINES (MI)	160
135 21	FIBER OPTIC COMMUNICATIONS LINES, OUTSIDE PLANT, MARINIZED (UNDERWATER/WETLAND) (MI).....	160
135 31	COPPER COMMUNICATIONS LINES, OUTSIDE PLANT, GEL FILLED (MI).....	161
135 32	COPPER COMMUNICATIONS LINES, OUTSIDE PLANT, AIR CORE (MI)	161

135 33	COPPER COMMUNICATIONS LINES, OUTSIDE PLANT, MARINIZED (UNDERWATER/WETLAND) (MI).....	161
135 34	COPPER COMMUNICATIONS LINES, OUTSIDE PLANT, ARMORED (MI)	161
136	AIRFIELD PAVEMENT LIGHTING	161
136 10	APPROACH LIGHTING (M/LF)	166
136 20	APRON AND PARKING AREA LIGHTING AND MARKINGS (M/LF)	168
136 30	RUNWAY EDGE LIGHTING AND MARKINGS AND CIRCLING GUIDANCE LIGHTING (M/LF)	168
136 35	RUNWAY CENTERLINE LIGHTING AND MARKINGS (M/LF)	170
136 36	SIMULATED CARRIER DECK LIGHTING (EA)	170
136 45	WHEELS-UP/WAVE-OFF LIGHTING (M/LF)	171
136 50	TAXIWAY LIGHTING AND MARKINGS (M/LF)	172
136 55	TOUCHDOWN ZONE LIGHTING AND MARKING (M/LF)	173
136 60	THRESHOLD LIGHTING AND MARKINGS (EA).....	174
136 65	HELIPORT LIGHTING AND MARKING (M/LF)	175
137	SHIP NAVIGATION AND TRAFFIC AIDS-BUILDINGS.....	177
137 10	METEOROLOGY AND OCEANOGRAPHY BUILDING (SF) [delete]	177
137 20	LIGHTHOUSE (M2/SF)	177
138	SHIP NAVIGATION AND TRAFFIC AIDS-OTHER THAN BUILDINGS ..	178
138 10	BEACON - SHIP (EA).....	178
138 20	NAVIGATION AID TARGET (EA).....	178
138 25	ANTENNA-NAVIGATION (EA)	178
140	LAND OPERATIONAL BUILDINGS	178
141	OPERATIONAL - BUILDINGS.....	178
141 11	AIR PASSENGER TERMINAL (SF)	179
141 12	AIR CARGO TERMINAL (SF)	179
141 20	AIRCRAFT FIRE AND RESCUE STATION (SF).....	180
141 25	COMBINED STRUCTURAL / AIRCRAFT FIRE / RESCUE STATION (SF)	181
141 30	AIRCRAFT LINE OPERATIONS BUILDING (SF)	182
141 40	AIRCRAFT OPERATIONS BUILDING (SF)	182
141 41	MARINE AIR TRAFFIC CONTROL UNIT (MATCU).....	183
141 42	AIR INTELLIGENCE SUPPORT CENTER (SF).....	183
141 60	VISUAL INFORMATION (VI) FACILITY (SF)	184
141 65	FLEET RECONNAISSANCE PHOTOGRAPHIC LABORATORY (SF)....	184

141 70	CONTROL TOWER (SF).....	185
141 81	GROUND CONTROL APPROACH CREW FACILITY (SF).....	185
141v 82	FULL PRESSURE SUIT FACILITY (SF)	185
141 87	LIQUID OXYGEN/NITROGEN FACILITY (SF).....	186
141 88	HARDENED AIRCRAFT SHELTER (SF)	187
142	OPERATIONAL – HELIUM PLANTS.....	187
142 10	HELIUM PROCESSING PLANT BUILDING (SF).....	187
142 19	HELIUM STORAGE BUILDING (SF).....	187
142 20	HELIUM STORAGE FACILITY (EA).....	187
143	SHIP AND OTHER OPERATIONAL-BUILDINGS	187
143 08	EXPEDITIONARY OPS BOAT MAINTENANCE REPAIR FACILITY (SF)	187
143 09	EXPEDITIONARY OPS SUPPORT FACILITY (SF)	188
143 10	EMERGENCY VEHICLE GARAGE (SF).....	188
143 11	OPERATIONAL VEHICLE GARAGE (SF).....	189
143 12	OPERATIONAL VEHICLE LAYDOWN AREA (SY).....	191
143 13	OPERATIONAL VEHICLE/EQUIPMENT CANOPY (SF)	193
143 15	RANGE OPERATIONS CENTER (SF).....	194
143 17	SPACE SURVEILLANCE FACILITY (SF).....	194
143 20	ORDNANCE OPERATIONS BUILDING (SF).....	194
143 21	AMMUNITION SEGREGATION FACILITY (SF).....	195
143 22	NAVY EXPLOSIVE ORDNANCE DISPOSAL SHORE DETACHMENT FACILITY (SF).....	195
143 23	NAVY EXPLOSIVE ORDNANCE DISPOSAL MOBILE UNIT (EODMU) FACILITY (SF).....	199
143 24	MARINE CORPS EXPLOSIVE ORDNANCE DISPOSAL FACILITY (SF)	202
143 25	SEAL TEAM BUILDING (SF).....	203
143 26	MARINE CORPS EXPLOSIVE ORDNANCE DISPOSAL COMPANY FACILITY (SF).....	203
143 35	REGISTERED PUBLICATIONS ISSUING OFFICE (SF)	206
143 40	COMPUTER PROGRAMMING OPERATIONS CENTER (SF) [delete] ..	206
143 41	AMPHIBIOUS OPERATIONS BUILDING (SF).....	206
143 45	ARMORY (SF).....	207
143 46	MARINE BARRACKS - GENERAL PURPOSE BUILDING (SF)	208
143 47	ALERT FORCE BUILDING (SF).....	209
143 55	TRANSIT SHED (SF)	209
143 60	EXPLOSIVES, SHIPPING/TRANSFER DEPOT (SF)	209

143 65	REGION/INSTALLATION OPERATIONS CENTER (SF)	210
143 70	RADIATION INSTRUMENT CALIBRATION FACILITY (SF)	213
143 75	POL OPERATIONS/SAMPLING/TESTING BUILDING (SF)	213
143 77	OPERATIONAL STORAGE (SF).....	214
143 78	OPERATIONAL HAZARDOUS/FLAMMABLE STORAGE (SF).....	214
143 80	MISSION OPERATION COMMAND AND CONTROL FACILITY (SF)....	215
143 85	JOINT RESERVE INTELLIGENCE CENTER (JRIC) (SF)	218
144 40	SCALE HOUSE (SF)	224
148	SHIP AND OTHER OPERATIONAL FACILITIES -OTHER THAN BUILDINGS	224
148 10	SHIP PROPULSION SUPPORT FACILITY (EA).....	224
148 15	SHIP WEAPONS HANDLING FACILITY (EA).....	224
148 17	SPACE SURVEILLANCE ANTENNA (EA)	225
148 20	ORDNANCE DEMOLITION AREA (EA).....	225
148 25	EXPLOSIVE TRUCK HOLDING YARD (SY).....	225
148 30	EXPLOSIVES RAILROAD CAR HOLDING YARD (EA).....	225
148 35	CONTAINER HOLDING YARD (SY)	226
148 40	CONTAINER TRANSFER FACILITY (ORDNANCE) (SY).....	226
148 45	RAIL/TRUCK RECEIVING STATION (ORDNANCE) (SY)	227
149	OPERATIONAL FACILITIES- OTHER THAN BUILDINGS	229
149 10	AIRCRAFT REVETMENT (EA)	229
149 15	FIXED POINT UTILITIES SYSTEM (EA).....	229
149 20	AIRCRAFT CATAPULT (EA) (DELETED).....	230
149 30	AIRCRAFT ARRESTING GEAR (EA).....	230
149 45	MISSILE LAUNCH FACILITY (EA).....	235
149 50	BLAST DEFLECTOR FENCE (EA)	235
149 62	TACTICAL Vehicle Wash Facility (SF)	236
FAC: 1496	236
149 85	EXPEDITIONARY AIR CONTROL SITE – MACS AND MASS (EA)	236
149 86	OPERATIONS SUPPORT SHED (EA).....	237
151	PIER FACILITIES	237
151 10	AMMUNITION PIER (FB)	245
151 20	GENERAL PURPOSE BERTHING PIER (FB)	245
151 40	FUELING PIER (FB).....	246
151 50	REPAIR PIER (FB).....	246
151 60	SUPPLY PIER (FB).....	246

151 70	ORDNANCE CONTAINER HANDLING PIER (FB)	247
151 71	DEGAUSSING PIER (FB)	247
151 80	DEPERMING PIER (FB).....	247
151 90	ACCESS TRESTLE TO PIERS AND WHARVES (SF).....	248
152	WHARVES	248
153	CARGO HANDLING OR STAGING AREAS	248
153 10	CARGO STAGING AREA (SY)	248
154	SEAWALLS, BULKHEADS, QUAYWALLS	249
154 10	SHALLOW WATER BULKHEAD AND QUAYWALL WITHOUT A RELIEVING PLATFORM (LF)	249
154 20	DEEP WATER BULKHEAD AND QUAYWALL WITH A RELIEVING PLATFORM (LF)	250
154 30	SEAWALLS AND RIP RAP (LF).....	250
155	SMALL CRAFT BERTHING	250
155 10	FLEET LANDING (FB).....	250
155 11	FLEET LANDING BUILDING (SF).....	251
155 20	SMALL CRAFT BERTHING (FB)	251
155 21	SMALL CRAFT BOATHOUSE (SF)	252
155 22	SMALL CRAFT BOAT RAMP FACILITY (EA).....	253
156	CARGO HANDLING FACILITIES – BUILDINGS.....	255
156 10	WATERFRONT TRANSIT SHED (SF).....	255
156 20	CONTAINER OPERATIONS BUILDING (SY).....	257
159	OTHER WATERFRONT OPERATIONAL FACILITIES	257
159 10	AIRCRAFT DOCKING FACILITY (EA).....	257
159 20	DEGAUSSING BUILDING (SF).....	257
159 21	DEGAUSSING RANGE (EA).....	258
159 30	DEPERMING BUILDING (SF).....	259
159 50	FERRY SLIP (EA)	259
159 64	WATERFRONT OPERATIONS BUILDING (SF).....	259
159 66	LANDING CRAFT RAMP (EA)	260
159 70	DREDGE CONTROL/PUMPING FACILITY (GM)	260
160	HARBOR AND COASTAL FACILITIES	260
161	HARBOR PROTECTION FACILITIES.....	260
161 20	FIXED NET ANCHORAGE (EA).....	260
161 30	WINCH HOUSE (EA).....	261
162	COASTAL PROTECTION FACILITIES	261

162 10	GUN EMPLACEMENTS (EA).....	261
163	MOORINGS.....	261
163 10	MOORING DOLPHIN (EA).....	261
163 20	MOORING PLATFORM (EA)	262
163 30	STAKE PILE MOORING (EA)	262
164	MARINE IMPROVEMENTS.....	263
164 10	BREAKWATER (LF).....	263
164 20	GROINS AND JETTIES (LF).....	263
164 30	LEVEES (LF).....	264
169	OTHER HARBOR AND COASTAL FACILITIES	264
169 10	HARBOR ENTRANCE CONTROL FACILITY (EA)	264
170	TRAINING FACILITIES	264
171	TRAINING BUILDINGS	265
171 10	ACADEMIC INSTRUCTION BUILDING (SF)	279
171 15	NAVY AND MARINE CORPS RESERVE TRAINING (SF).....	281
171 17	TV CENTER FOR INSTRUCTIONAL MATTER (SF)	299
171 20	APPLIED INSTRUCTION BUILDING (SF)	299
171 21	DECONTAMINATION TRAINING FACILITY (DELETED).....	306
171 30	PHYSICAL EDUCATION FACILITY (SF)	307
171 35	OPERATIONAL TRAINER FACILITY (SF).....	308
171 36	RADAR SIMULATOR FACILITY (SF).....	311
171 40	DRILL HALL (SF)	311
171 45	MOCK-UP AND TRAINING AID PREPARATION CENTER (SF).....	312
171 50	SMALL ARMS RANGE - INDOORS (SF).....	312
171 60	RECRUIT PROCESSING BUILDING (SF).....	313
171 77	TRAINING MATERIAL STORAGE (READY ISSUE / SHOP STORES / MISC) (SF)	313
172 30	GAS CHAMBER (SF).....	313
173 10	RANGE OPERATIONS BUILDING (SF).....	313
173 11	RANGE SUPPORT BUILDING (SF).....	314
173 20	TRAINING AIDS CENTER (SF)	314
173 30	COVERED TRAINING AREA (SF)	314
173-40	observation tower/bunker (sf)	315
174 10	MANEUVER/TRAINING AREA, LIGHT FORCES (AC).....	315
174 11	MANEUVER/TRAINING AREA, AMPHIBIOUS FORCES (AC).....	316
174 12	LAND NAVIGATION COURSE (AC)	316

174 13	FIELD TRAINING AREA (AC)	316
174 20	MANEUVER/TRAINING AREA, HEAVY FORCES (AC)	317
174 30	IMPACT AREA DUDDDED (AC).....	317
174 31	IMPACT AREA NON-DUDDDED (AC).....	318
174 40	PERSONNEL/EQUIPMENT DROP ZONE (AC).....	318
175 01	AUTOMATIC RIFLE RANGE (AC)	318
175 02	NON-STANDARD SMALL ARMS RANGE (AC).....	319
175 10	BASIC 10M-25M FIRING RANGE (ZERO) (AC)	319
175 20	AUTOMATED FIELD FIRE (AFF) RANGE (AC).....	319
175 30	RECORD FIRE RANGE, NON-AUTOMATED (AC)	320
175 31	AUTOMATED RECORD FIRE (ARF) RANGE (AC).....	320
175 32	MODIFIED RECORD FIRE RANGE (AC)	320
175 50	RIFLE KNOWN DISTANCE (KD) RANGE (AC)	321
175 60	SNIPER FIELD FIRE RANGE (AC).....	321
175 61	AUTOMATED SNIPER FIELD FIRE RANGE (AC)	321
175 70	PISTOL KNOWN DISTANCE (KD) RANGE (AC).....	322
175 71	COMBAT PISTOL/MP FIREARMS QUALIFICATION COURSE (AC).....	322
175 72	AUTOMATED COMBAT PISTOL/MP FIREARMS QUALIFICATION COURSE (AC).....	322
175 73	SUBMACHINE GUN RANGE (AC).....	323
175 80	MACHINE GUN TRANSITION RANGE (AC)	323
175 81	MACHINE GUN FIELD FIRE RANGE (AC).....	323
175 82	AUTOMATED MULTIPURPOSE MACHINE GUN (MPMG) RANGE (AC)	324
176 10	GRENADE LAUNCHER RANGE (AC).....	324
176 20	40MM (GRENADE) MACHINE GUN QUALIFICATION RANGE (AC).....	324
176 30	LIGHT ANTIARMOR WEAPONS RANGE SUBCALIBER (AC).....	325
176 31	LIGHT ANTIARMOR WEAPONS RANGE LIVE (AC)	325
176 40	ANTIARMOR TRACKING AND LIVE-FIRE RANGE (AC).....	325
176 41	AUTOMATED ANTIARMOR TRACKING AND LIVE-FIRE RANGE (AC)	326
176 50	FIELD ARTILLERY DIRECT FIRE RANGE (AC)	326
176 60	TANK/FIGHTING VEHICLE STATIONARY GUNNERY RANGE (AC)....	326
176 70	MORTAR RANGE (AC).....	327
176 71	FIELD ARTILLERY INDIRECT FIRE RANGE (AC).....	327
176 80	MORTAR SCALED RANGE (AC).....	327
176 81	FIELD ARTILLERY SCALED RANGE (AC).....	328

176 90	SCALED GUNNERY RANGE (1:30 AND 1:60) (AC)	328
176 91	SCALED GUNNERY RANGE (1:5 AND 1:10).....	328
177 10	MULTIPURPOSE TRAINING RANGE (AC)	329
177 11	AUTOMATED MULTIPURPOSE TRAINING RANGE (AC).....	329
177 20	TANK/FIGHTING VEHICLE PLATOON BATTLE RUN (AC).....	329
177 21	TANK/FIGHTING VEHICLE MULTIPURPOSE RANGE COMPLEX, LIGHT, AUTOMATED (AC).....	330
177 22	TANK/FIGHTING VEHICLE MULTIPURPOSE RANGE COMPLEX, HEAVY, AUTOMATED (AC).....	330
177 30	FIRE AND MOVEMENT RANGE (AC)	331
177 40	SQUAD DEFENSE RANGE (AC).....	331
177 50	INFANTRY SQUAD BATTLE COURSE (AC).....	331
177 51	AUTOMATED INFANTRY SQUAD BATTLE COURSE (AC)	332
177 52	INFANTRY PLATOON BATTLE COURSE (AC)	332
177 53	AUTOMATED INFANTRY PLATOON BATTLE COURSE (AC).....	332
177 60	MOUT ASSAULT COURSE (MAC) (AC).....	333
178 10	LIVE HAND GRENADE RANGE (AC).....	333
178 20	ENGINEER QUALIFICATION RANGE, NON-STANDARDIZED (AC).....	333
178 21	ENGINEER QUALIFICATION RANGE, AUTOMATED / STANDARDIZED (AC)	334
178 30	LIGHT DEMOLITION RANGE (AC).....	334
179	TRAINING FACILITIES OTHER THAN BUILDINGS	334
179 01	BAYONET ASSAULT COURSE (AC).....	335
179 02	TARGET DETECTION (TD) RANGE, NON-FIRING	335
179 03	HAND TO HAND COMBAT PIT	335
179 04	PRISONER OF WAR TRAINING AREA.....	336
179 05	MINE WARFARE AREA (AC).....	336
179 06	WHEELED VEHICLE DRIVERS COURSE (AC)	336
179 07	TRACKED VEHICLE DRIVERS COURSE (AC).....	336
179 08	AMPHIBIOUS VEHICLE TRAINING AREA (AC).....	337
179 09	SHIP LOADING AND UNLOADING MOCKUP (SF).....	337
179 10	AIRCRAFT GUNNERY, BOMBING, AND ROCKET RANGES (EA)	337
179 11	AIR TRANSPORT MOCKUP (SY).....	341
179 12	ELEVATED TRAINING TOWER/PLATFORM	341
179 13	SUSPENDED HARNESS MOCKUP	341
179 14	MOCKUP JUMP TOWER.....	341

179 15	UNDERWATER FORDING SITE	341
179 16	COMBAT TRAIL (AC).....	341
179 17	RAPPELLING TRAINING AREA (EA).....	342
179 18	AIRFIELD DEMOLITION RANGE (ADR) (SY)	342
179 19	TIMBER BRIDGE AREA.....	342
179 20	PANEL BRIDGE AREA	342
179 22	FLOATING BRIDGE SITE	342
179 24	WATER SUPPLY TRAINING AREA (EA).....	343
179 25	AIRFIELD SITE SELECTION TRAINING AREA (AC).....	343
179 26	AERIAL GUNNERY RANGE (AC).....	343
179 30	SURFACE PROJECTILE RANGE (EA).....	343
179 31	MEDIUM HEAVY EQUIPMENT TRAINING AREA (AC).....	343
179 32	DECONTAMINATION TRAINING SITE (AC)	344
179 33	POL TRAINING AREA (AC)	344
179 35	WEAPONS RANGE OPERATIONS TOWER (EA).....	344
179 36	CLOSE AIR SUPPORT RANGE (AC)	345
179 37	AERIAL BOMBING RANGE (AC).....	345
179 40	SMALL ARMS RANGE - OUTDOOR (EA)	345
179 41	AIR DEFENSE MISSILE FIRING RANGE (AC)	346
FAC: 1794	346
179 45	TRAINING MOCK-UPS (EA).....	346
179 50	TRAINING COURSE (AC).....	346
179 51	UNENCLOSED FIRE FIGHTER TRAINER (SF)	347
179 53	ENCLOSED FIRE FIGHTER TRAINER FACILITY (SF).....	347
179 54	DAMAGE CONTROL (WET) TRAINER (SF).....	347
179 55	COMBAT TRAINING POOL/TANK (EA).....	348
179 60	PARADE AND DRILL FIELD (AC).....	348
179 61	COMBAT IN CITIES FACILITY (AC).....	348
179 62	MOUT COLLECTIVE TRAINING FACILITY (SMALL) (AC).....	348
179 63	MOUT COLLECTIVE TRAINING FACILITY (LARGE) (AC).....	349
179 70	RADAR BOMB SCORING FACILITY (EA).....	349
179 71	ELECTRONIC WARFARE TRAINING RANGE (EA).....	349
179 72	UNDERWATER TRACKING TRAINING RANGE (EA).....	349
179 81	INFILTRATION COURSE (AC)	350
179 91	CONFIDENCE COURSE (AC)	350
179 92	OBSTACLE COURSE (AC).....	350

110 AIRFIELD PAVEMENTS

110-1 PAVEMENTS

This category group includes all pavements necessary for use by operational aircraft. Planning for pavements shall include all safety clearances and facilities required to provide a fully operational field, complete with accessories such as aircraft tie-downs and pavement marking. Airfield pavement lighting is considered separately under 133/134 series category codes. See NAVFAC p-80.3, airfield safety clearances, for criteria on obstruction clearances and clear zones related to airfields and heliports. Clearances and separations related to a specific pavement type (for example: the separation between parallel runways) is given under the applicable category code within the 110 code series.

Facilities considered in this category group are:

- 111 Airfield Pavements - Runways (includes helipads)
- 112 Airfield Pavements - Taxiways
- 113 Airfield Pavements - Aprons
- 116 Airfield Pavements - Other

110-2 CLASS A AND B RUNWAY CRITERIA

The airfield criteria published herein differs from previous criteria in that it has been revised to conform to the standards published in the Unified Facilities Criteria (UFC), 3-260-01, Airfield and Heliport Planning and Design and the Air Installations Compatible Land Use Zone (AICUZ) program defined in OPNAVINST 11010.36B. The unified facilities criteria are defined in terms of class A and B runways and their supporting taxiways, aprons, etc. The A and B runways and the application of an A or B designation to a particular runway is explained in NAVFAC P-80.3 and summarized in Table 110-A. All Navy and USMC supporting pavements such as taxiways, aprons, etc., shall be considered class B unless their use is totally dedicated to supporting a runway which has been designated class A and the application of class A standard has been approved by Headquarters NAVFACENGCOM and NAVAIRSYSCOM.

Table 110-1. Class A and Class B Runway Characteristics

Characteristic Description	Class A Runway	Class B Runway
Length	Based on Aircraft Ground Run, adjusted for temperature and altitude correction times the factor of safety	
Width	75 feet (22.9 meters)	200 feet (61 meters)
Width of Shoulders	25 feet (7.6 meters)	150 feet (45.7 meters)
Longitudinal grades of Runway and Shoulders	Maximum 1.0%	Maximum 1.0%
Longitudinal Runway grade changes	Maximum 0.167% per 100 lineal feet (30.5 lineal meters) of Runway	Maximum 0.167% per 100 lineal feet (30.5 lineal meters) of Runway
Transverse grade of Runway	Minimum 1.0% to a Maximum 1.5%	Minimum 1.0% to a Maximum 1.5%
Transverse grade of Shoulder	5.0% for first 10 feet (3.05 meters) then Minimum 2.0% to a Maximum 3.0%	Minimum 2.0% to a Maximum 3.0%
Runway lateral clearance distance (Primary Surface)	500 feet (152 meters) from centerline of Runway	1,000 feet (305 meters) from centerline of Runway. For Taxiways: 500 feet (152 meters) from centerline of Taxiway to centerline of Runway.
Longitudinal grades within the Primary Surface	Maximum 10.0% exclusive of Pavements, Shoulders, and cover over Drainage Structures.	Maximum 10.0% exclusive of Pavements, Shoulders, and cover over Drainage Structures.
Transverse grades within Primary Surface (in direction of surface drainage)	Minimum 2.0% prior to channelization, Maximum 10.0%.	Minimum 2.0% prior to channelization, Maximum 10.0%.
Distance between centerlines of Parallel Runways: i.) VFR ii) VFR with intervening parallel taxiway iii) IFR using simultaneous approaches	Not Applicable Not Applicable Not Applicable	1,000 feet (305 meters) 2,075 feet (632 meters) 4,300 feet (1,320 meters)
Sight distance (any two points 8 feet (2.44 meters) above the pavement must be mutually visible).	Minimum 3,000 feet (914 meters) (2 points above 5 feet (1.52 meters) above pavement visible).	Minimum 5,000 feet (1,520 meters)

RUNWAY CLASSIFICATION. The classification is dependent on the type of aircraft, which operate from the runway. Table 110-2 provides the runway classifications for all Navy and Marine Corps aircraft as well as aircraft from other services or government agencies. These aircraft are listed by aircraft type. Each type includes all model variants.

Transient aircraft from other services or government agencies are special exceptions in the planning of Navy and Marine Corps air stations. Individual justification must be made for these cases where runway length must be extended to allow for the landing and takeoff of these aircraft.

Table 110-2. Runway Classifications by Aircraft Type
(Aircraft are listed by type, each type includes all models)

Class A Runways		
C-1	C-26	UV-18
C-2	E-1	V-22 (1)
C-12	E-2	T-44
C-20	OV-1	U-21
C-21	T-6	
C-23	T-34	
Class B Runways		
A-6	DASH-7	SR-71
A-10	DASH-8	T-1
AV-8	E-3	T-2
B-1	E-4	T-37
B-2	E-6	T-38
B-52	F-5	T-39
C-5	F-14	T-42
C-9	F-15	T-45
C-17	F-16	TR-1
C-40A	C-10	F-22
U-2	F/A-18	F-117
C-130	P-3	
C-141	S-3	

Note: V-22 aircraft is a rotary wing aircraft which operates as a rotary wing aircraft on a Class A runway and operates as either a fixed wing or rotary wing aircraft on taxiways associated with Class A runways.

Class A runways are primarily used by small light aircraft as indicated in Table 110-2 and the runway should not have the potential for development for use by heavier aircraft or have a foreseeable requirement for such use. Ordinarily, Class A runways are less than 8,000 feet (2,440 meters) long and less than 10 percent of the operations involve

class B type aircraft. Class B runways are primarily intended for high performance and large heavy aircraft as indicated in Table 110-A. Basic training outlying fields used by T-34 aircraft have specified special criteria.

The classification of Navy and Marine Corps runways is determined as a part of the Air Installations Compatible Land Use Zone (AICUZ) program and is published in AICUZ study for a particular installation. NAVFACENGCOM and NAVAIRSYSCOM concurrence and CMC/CNO approval is required prior to classifying any runway Class A or B. This approval is obtained via approval of the AICUZ study.

111 AIRFIELD PAVEMENTS - RUNWAYS

Series 111 Category Codes include criteria for runways for fixed wing aircraft and runways or landing pads for rotary wing aircraft. Runways are prepared surfaces for the landing and takeoff of both fixed wing and rotary wing aircraft. Landing pads are prepared surfaces for the Vertical Takeoff and Landing (VTOL) of rotary wing aircraft (including V-22). The number of runways and/or landing pads is determined by the expected traffic density, airfield mission, operational procedures, and environmental factors. Runway orientation is determined from analysis of wind data, terrain, noise levels generated, and local development conditions.

111 10 RUNWAY/FIXED WING (M2/SY)

FAC: 1111

BFR Required: Y

Design Criteria: UFC 3-260-01, Airfield and Heliport Planning and Design

Planning Criteria: NAVFAC P-80.1, Facility Planning Factors for Naval Shore Activities; Appendix C, Runway Capacity Handbook – Fixed Wing, NAVFAC P-80.3, Facility Planning Factor Criteria for Navy and Marine Corps Shore Installations; Appendix E, Airfield Safety Clearances, UFC 3-260-01, Airfield and Heliport Planning and Design

11110-1 DESCRIPTION. Runways are prepared surfaces for the landing and takeoff of aircraft. The number of runways required is determined by the expected traffic density, airfield mission, operational procedures and environmental factors. Runway orientation is determined from analysis of wind data, terrain, noise levels to be generated and local development planning.

11110-2 CRITERIA. The following standards apply to fixed-wing runways at all Navy and Marine Corps air installations, including outlying fields, unless specifically noted otherwise. Deviation from these standards must be approved by the Naval Air Systems Command.

11110-3 RUNWAY WIDTH. The standard width for all runways constructed prior to June 1981 is 61 meters (200 feet). For runways planned after June 1981, the standard width shall be 61 meters (200 feet) for all Class B runways and 22.9 meters (75 feet) for Class A runways except those Class A runways where T-6, T-34, and T-44 aircraft are operated by the Naval Air Training Command. In this case, the runway width shall be

increased to 61 meters (200 feet) in order to simulate the runway conditions found at fleet stations. (See 110 introduction for explanation of class A and B Standards.)

11110-4 LENGTH. The maximum planned length of a runway shall be long enough to accommodate a selected critical aircraft in takeoff and landing operations under stipulated load and environmental conditions. The critical aircraft for a station is defined as one which:

- a. Is or will be assigned to the installation or is to be supported by the installation in accordance with the mission assigned by the major claimant/CNO.
- b. Requires the longest Takeoff Ground Run (TGR) or landing roll of those aircraft meeting the above stipulation.

11110-5 CRITICAL AIRCRAFT. The basic TGR or landing roll for the critical aircraft can be obtained from the pertinent Naval Air Training and Operating Procedures Standardization (NATOPS) Manual. Basic TGR is defined as the distance an aircraft requires to lift off at a given gross weight on a level runway surface at sea level (Barometric pressure 29.92 inches Hg.) with 59 degrees Fahrenheit ambient temperature and under conditions of zero wind. The TGR in most cases is the controlling characteristic.

Table 11110-1 provides minimum and maximum TGR and minimum and maximum landing roll for a group of selected Navy and Marine Corps aircraft. The minimum TGR (TGR min) is defined as the minimum takeoff distance an aircraft requires to lift off at minimum takeoff weight on a level runway surface at sea level (Barometric pressure 29.92 inches Hg.) with 59 degrees Fahrenheit ambient temperature and under conditions of zero wind. The maximum TGR (TGR max) is defined as the minimum takeoff distance an aircraft requires to lift-off at maximum takeoff weight (wartime weight) on a level runway surface at sea level (Barometric pressure 29.92 inches Hg.) with 59 degrees Fahrenheit ambient temperature and under conditions of zero wind. When local operating conditions are unavailable, use maximum TGR to compute runway length when TGR is the controlling characteristic.

Table 11110-1. Selected Navy and Marine Corps Aircraft Takeoff Ground Rolls (TGR) and Landing Distances

Aircraft Type	Min. Takeoff Ground Roll (TGR min) (1) (feet/meters)	Max. Takeoff Ground Roll (TGR max) (2) (feet/meters)	Min. Landing Distance (feet/meters) (3)	Max. Landing Distance (feet/meters) (4)
A-6	950/290	5,000/1,524	1,800/549	4,800/1,463
EA-6B	1,400/427	4,010/1,222	1,800/549	2,300/701
C-1	455/139	1,700/518	1,120/341	1,720/524
C-2	1,150/351	2,500/762	1,300/396	2,250/686
C-9	4,000/1,219	4,500/1,372	2,450/747	2,500/762
C-12(B)	1,680/512	1,900/579	1,000/305	1,100/335
C-12(F/M)	1,700/518	1,900/579	1,000/305	1,100/335
C-130	1,800/549	4,700/1,433	1,150/351	2,020/616
KC-130	1,820/555	4,700/1,433	1,150/351	2,020/616
E-1	600/183	1,200/366	2,550/777	2,400/732
E-2	1,200/366	2,100/640	1,300/396	1,500/457
E-6	2,980/908	5,850/1,783	2,300/701	3,820/1,164
F-4	1,200/366	3,500/1,067	2,000/610	2,500/762
F-14(A)	1,600/488	3,650/1,113	2,150/655	3,150/960
F-14(B/D)	1,800/549	4,600/1,402	2,450/747	3,000/914
F/A-18 (5)	1,000/305	3,600/1,097	2,200/671	4,300/1,311
F/A-18 (6)	1,000/305	3,400/1,036	2,200/671	4,400/1,341
F/A-18 (7)	1,305/398	3,680/1,122	Not Available	4,160/1,268
(E)P-3(A/B/E)	1,600/488	3,000/914	1,500/457	2,100/640
P-3(C)	2,100/640	4,000/1,219	1,400/427	2,100/640
(E)S-3(A/B)	1,080/329	3,400/1,036	1,750/533	2,700/823
T-2	900/274	1,600/488	1,950/594	4,300/1,311
T-28(B)	1,000/305	2,050/625	920/280	1,520/463
T-28(C)	1,000/305	2,050/625	920/280	1,940/591

Table 11110-1. Selected Navy and Marine Corps Aircraft Takeoff Ground Rolls (TGR) and Landing Distances (Continued)

Aircraft Type	Min. Takeoff Ground Roll (TGR min) (1) (feet/meters)	Max. Takeoff Ground Roll (TGR max) (2) (feet/meters)	Min. Landing Distance (feet/meters) (3)	Max. Landing Distance (feet/meters) (4)
T-34	1,200/366	1,400/427	850/259	1,000/305
T-39	1,400/427	2,950/899	1,550/472	4,200/1,280
T-44	1,000/305	1,500/457	950/290	1,100/335
T-45	1,340/408	2,250/686	3,200/975	3,950/1,204
AV-8(A)	825/251	2,200/671 (8)	3,500/1,067	5,000/1,524
AV-8(B)	800/244	2,600/792	3,400/1,036	8,250/2,515
(T)AV-8(B)	900/274	2,600/792	3,750/1,143	8,250/2,515
V-22	Not Available	Not Available	0/0 (9)	0/0 (9)

- Note:
- (1) Minimum takeoff distance at minimum takeoff weight.
 - (2) Minimum takeoff distance at maximum takeoff weight.
 - (3) Minimum landing ground roll required at minimum landing gross weight.
 - (4) Minimum landing ground roll required at maximum landing gross weight.
 - (5) (A/B/C/D) model Hornet with F404-GE-400 engine.
 - (6) (A/B/C/D) model Hornet with F404-GE-402 engine.
 - (7) (E/F) model Super Hornet with F414-GE-400 engine.
 - (8) Weight limited to 21.3 k-lb by tire speed.
 - (9) Vertical landing.

11110-6 BASIC LENGTH AND CORRECTION FACTORS. The planned runway length for an aircraft is the TGR or landing roll (whichever governs) of the critical aircraft, corrected for nonstandard conditions of altitude, temperature, and effective gradient, and with an appropriate safety factor applied. The result is rounded to the next 30.5 meters (100 feet). (Additional corrections are to be applied to crosswind runways and runways used by T-34 aircraft for basic training.) The safety factor allows for variation in pilot techniques, runway surface conditions, wind, minor mechanical difficulties, and psychological factors. Correction and safety factors are applied as follows:

11110-6.1 Altitude. Increase runway length (TGR or landing roll) by 1.1 percent for each 30.5 meters (100 feet) the site is above sea level. See Table 11110-2 for altitude correction factors.

11110-6.2 Temperature. Increase above result by 0.66 percent for each degree F the anticipated mean high temperature is above 59 degrees F. The mean highest temperature is defined as the average of the highest temperature recorded each day during the month which has the highest average daily maximum temperature. See Table 11110-2 for temperature correction factors.

11110-6.3 Safety Factor. Multiply the above result by 1.6 for all runways except those at Air Training Command air installations where a safety factor of 2.0 shall be applied.

11110-6.4 Effective Gradient. Increase the above result by 10 percent for each 1 percent of effective gradient. Effective gradient is the maximum difference in elevation along the centerline of the runway divided by the runway length and expressed as a percent.

11110-6.5 Round off. Final runway length is the result of the foregoing calculations rounded off to the next higher 30.5 meters (100 feet).

11110-6.6 Basic Training Runways. At basic training runways used by T-34 aircraft, 305 meters (1,000 feet) shall be added to the computed runway requirement. The additional runway length is required to practice precautionary emergency landings.

11110-6.7 Example. See the example computation at the end of Category Code 111 10.

11110-7 CROSSWIND RUNWAY. The foregoing discussion applies to the primary runway. When the primary runway provides less than 95 percent wind coverage (that is, when a 15 knot crosswind component occurs more than 5 percent of the time), it becomes necessary to consider a crosswind runway. Justification based on wind data and operational needs is required before planning action is taken. In those cases where a crosswind runway is authorized for planning, the length is computed as for the primary runway with the exception that the takeoff ground run (or landing roll) is reduced by 20 percent. This accounts for headwinds, 15 knots or more, which normally will be encountered on the crosswind runway. If operational conditions, wind data, or runway configuration are such as to indicate that a headwind other than 15 knots should be planned for, then the NATOPS Manual for the critical aircraft should be consulted, and the appropriate TGR computed.

11110-8 RUNWAY SEPARATIONS/CLEARANCES. See NAVFAC P-80.3, Airfield Safety Clearances or UFC 3-260-01, Airfield and Heliport Planning and Design for guidelines for determining obstructions to air navigation and the definition of airfield imaginary surfaces. The following lateral separations are required between runways and other airfield pavements. Deviations from criteria require a waiver from the Naval Air Systems Command unless specifically exempted from waiver per NAVFAC P-80.3.

11110-8.1 Parallel Runways. A minimum of 305 meters (1,000 feet) is required between centerlines of parallel runways. The separation shall be increased to 1,311 meters (4,300 feet) if simultaneous Instrument Flight Rule (IFR) operations are to be flown from the parallel runways.

11110-8.2 Parallel Taxiway. A minimum of 152.4 meters (500 feet) is required between the centerline of a runway and the centerline of a parallel taxiway. (Note: Aircraft using the parallel taxiway are under the direction of the air control

tower and therefore are not considered an obstruction even though the taxiway lies within the runway primary surface).

11110-8.3 Parking Apron. The edge of a parking apron, including its peripheral taxilane, shall be sited outside the runway primary surface. Aircraft shall be parked such that they do not penetrate the 7:1 transitional surface.

11110-8.4 Objects. Objects shall be sited outside the runway primary surface and such that they do not penetrate the 7:1 transitional surface or other imaginary surfaces defined in NAVFAC P-80.3.

Figure 11110-1. Example Computation 1

<i>The following is an illustrative example of the runway length computation:</i>			
<u>GIVEN:</u>	<i>Patrol Plane Air Station</i>	-	<i>P-3C is critical aircraft</i>
	<i>Elevation of Site</i>	-	<i>(91.5 meters) 300 feet above mean sea level</i>
	<i>Mean Highest Temperature</i>	-	<i>70 degrees (F)</i>
	<i>Effective Runway Gradient</i>	-	<i>0.8%</i>
<i>Since local operating conditions are not provided, use maximum TGR or maximum LD</i>			
<i>From Table 111-10A, TGR max (P-3C) = 1,219.5 meters (4,000 feet).</i>			
<i>From Table 111-10A, LD max (P-3C) = 640 meters (2,100 feet).</i>			
<i>Since TGR max is greater than LD max, use TGR max.</i>			
<i>Altitude Correction (1)</i>	<i>(91.5) 300</i>	$\times 1.1\% = 3.3\%$	
	<i>(30.5) 100</i>		
			$1,219.5 (4,000) \times 1.033 = 1,259.7 \text{ meters } (4,132 \text{ feet})$
<i>Temperature Correction (1)</i>	<i>(70-59)</i>	$\times 0.66\% = 7.26\%$	
			$1,259.7 (4,132) \times 1.0726 = 1,351.1 \text{ meters } (4,432 \text{ feet})$
<i>Safety Factor Correction</i>	<i>1,351.1 meters (4,432 feet)</i>	$\times 1.6 = 2,161.8 \text{ meters } (7,091 \text{ feet})$	
<i>Effective Gradient</i>	<i>0.8</i>	$\times 10\% = 8\% \text{ increase}$	
			$2,161.8 \text{ meters } (7,091 \text{ feet}) \times 1.08 = 2,334.7 \text{ meters } (7,658 \text{ feet})$

Note: (1) Table 111-10B may be used when temperature and altitude data are available.

Figure 11110-2. Example Computation 2

The following is an illustrative example of the runway length computation:

GIVEN: Air Station - F/A-18 "Hornet" w/ F404-GE-402 engine is critical aircraft
 - (15.2 meters) 50 feet above

Mean Highest Temperature - 80 degrees (F)
 Effective Runway Gradient - 0.5%

Since local operating conditions are not provided, use maximum TGR or maximum LD
 From Table 111-10A, TGR max (F/A-18 w/F404-GE-402) = 1,036 meters (3,400 feet).
 From Table 111-10A, LD max (F/A-18 w/F404-GE-402) = 1,341 meters (4,400 feet).

Since LD max is greater than TGR max, use LD max.

Altitude Correction (1) $\frac{(15.2) 50}{(30.5) 100} \times 1.1\% = 0.55\%$

$1,341 (4,400) \times 1.0055 = 1,348.4 \text{ meters } (4,424 \text{ feet})$

Temperature Correction (1) $(80-59) \times 0.66\% = 13.86\%$

$1,348.4 (4,424) \times 1.1386 = 1,535.3 \text{ meters } (5,037 \text{ feet})$

Safety Factor Correction $1,535.3 \text{ meters } (5,037 \text{ feet}) \times 1.6 = 2,456.5 \text{ meters } (8,059 \text{ feet})$

Effective Gradient $0.5 \times 10\% = 5\% \text{ increase}$

$2,456.5 \text{ meters } (8,059 \text{ feet}) \times 1.05 = 2,579.3 \text{ meters } (8,462 \text{ feet})$

Round off = 2,591.5 meters (8,500 feet).

Note: Table 11110-2 may be used when temperature and altitude data are available.

Table 11110-2. Runway Temperature and Altitude Corrections

Installation	Elevation (feet/meters)	Mean Highest daily temp. hottest month (Deg. F)	Altitude Correction Factor	Temperature Correction Factor
Andrews, AFB	280 / 85.4	89	1.0308	1.198
Aransas, AP	24 / 7.3	90	1.0026	1.2046
Atlanta, NAS	1,068 / 325.6	89	1.1175	1.198
Atlantic, MCOLF	20 / 6.1	89	1.0022	1.198
Atsugi, NAF	205 / 62.5	87	1.0226	1.1848
Barin Field, NOLF	54 / 16.5	91	1.0059	1.2112
Barking Sands, NS	16 / 4.9	87	1.0018	1.1848
Beaufort, MCAS	36 / 11.0	91	1.004	1.2112
Bogue Field, MCALF (1)	22 / 6.7	89	1.0024	1.198
Brewton Field, NOLF	99 / 30.2	91	1.0109	1.2112
Brunswick, NAS	75 / 22.9	80	1.0083	1.1386
Cabaniss Field, NOLF	30 / 9.1	93	1.0033	1.2244
Camp Davis, MCOLF	60 / 18.3	90	1.0066	1.2046
Camp Pendleton, MCAS	73 / 22.3	82	1.008	1.1518
Cherry Point, MCAS	28 / 8.5	89	1.0031	1.198
China Lake, NAWS	2,283 / 696.0	103	1.2511	1.2904
Choctaw, NOLF	102 / 31.1	91	1.0112	1.2112
Corpus Christi, NAS	19 / 5.8	93	1.0021	1.2244
Coupeville, NOLF	199 / 60.7	72	1.0219	1.0858
Diego Garcia, NSF	9 / 2.7	88	1.001	1.1914
Doha, IAP	35 / 10.7	106	1.0039	1.3102
El Centro, NAF	3,28125	105	0.9946	1.3036
Middleton Field (Evergreen), NOLF	260 / 79.3	91	1.0286	1.2112
Fallon, NAS	3,934 / 1,199.4	93	1.4327	1.2244
Fentress, NALF	16 / 4.9	87	1.0018	1.1848
Fort Worth, NAS JRB	650 / 198.2	97	1.0715	1.2508

Table 11110-2. Runway Temperature and Altitude Corrections (Continued)

Installation	Elevation (feet/meters)	Mean Highest daily temp. hottest month (Deg. F)	Altitude Correction Factor	Temperature Correction Factor
Fujairah, IAP	152 / 46.3	94	1.0167	1.231
Futema, MCAS	247 / 75.3	87	1.0272	1.1848
Guantanamo Bay, NAS	56 / 17.1	93	1.0062	1.2244
Harold Field, NOLF	150 / 45.7	92	1.0165	1.2178
Holley Field, NOLF	39 / 11.9	91	1.0043	1.2112
Hurghada, EG	52 / 15.8	92	1.0057	1.2178
Ie Jima, AAF	246 / 75.0	88	1.0271	1.1914
Imperial Beach, NOLF	24 / 7.3	78	1.0026	1.1254
Iwakuni, MCAS	7 / 2.1	88	1.0008	1.1914
Jacksonville, NAS	22 / 6.7	91	1.0024	1.2112
Jeddah, AB	48 / 14.6	90	1.0053	1.2046
Joe Williams, NOLF	540 / 164.6	93	1.0594	1.2244
Kaneohe Bay, MCAF	17 / 5.2	83	1.0019	1.1584
Keflavik, NAS	171 / 52.1	55	1.0188	0.9736
Key West, NAF	6 / 1.8	90	1.0007	1.2046
Kingsville, NAS	50 / 15.2	95	1.0055	1.2376
Lakehurst, NAES	103 / 31.4	86	1.0113	1.1782
Lemoore, NAS	234 / 71.3	98	1.0257	1.2574
Masirah, AB	64 / 19.5	95	1.007	1.2376
Mayport, NS	17 / 5.2	91	1.0019	1.2112
Meridian, NAS	317 / 96.6	93	1.0349	1.2244
Miramar, MCAS	478 / 145.7	78	1.0526	1.1254
Misawa, NAF	119 / 36.3	81	1.0131	1.1452
Muharraq, BH	6 / 1.8	108	1.0007	1.3234
Naha, NAF	11 / 3.4	88	1.0012	1.1914
Naples (Capodichino), NSA	294 / 89.6	85	1.0323	1.1716

Table 11110-2. Runway Temperature and Altitude Corrections (Continued)

Installation	Elevation (feet/meters)	Mean Highest daily temp. hottest month (Deg. F)	Altitude Correction Factor	Temperature Correction Factor
New Orleans, NAS JRB	3 / 0.9	92	1.0003	1.2178
New River, MCAS(H)	25 / 7.6	90	1.0028	1.2046
North Island, NAS	26 / 7.9	75	1.0029	1.1056
Norfolk, NS Chambers Field	15 / 4.6	88	1.0017	1.1914
Oak Grove, MCOLF	27 / 8.2	88	1.003	1.1914
Oceana, NAS	22 / 6.7	87	1.0024	1.1848
Orange Grove, NALF	257 / 78.3	95	1.0283	1.2376
Pace Field, NOLF	180 / 54.9	91	1.0198	1.2112
Patuxent River, NAS	39 / 11.9	86	1.0043	1.1782
Pensacola, NAS	30 / 9.1	91	1.0033	1.2112
Point Mugu, NAS	12 / 3.7	75	1.0013	1.1056
Quantico, MCAS	11 / 3.4	88	1.0012	1.1914
Roosevelt Roads, NS	38 / 11.6	88	1.0042	1.1914
Rota, NS	86 / 26.2	85	1.0095	1.1716
San Clemente, NALF	182 / 55.5	79	1.02	1.132
San Nicolas, NOLF	504 / 153.7	79	1.0554	1.132
Santa Rosa, NOLF	150 / 45.7	92	1.0165	1.2178
Saufley Field, NOLF	85 / 25.9	91	1.0094	1.2112
Sigonella, NAS	81 / 24.7	89	1.0089	1.198
Silverhill, NOLF	129 / 39.3	91	1.0142	1.2112
Souda Bay, NSA	492 / 150	84	1.0541	1.165
Spencer Field, NOLF	151 / 46.0	92	1.0166	1.2178
Summerdale Field, NOLF	149 / 45.4	91	1.0164	1.2112
Taszar, AB	526 / 160.4	79	1.0579	1.132
29 Palms, MCAGCC (1)	2,055 / 626.5	106	1.2261	1.3102
Waldron Field, NOLF	25 / 7.6	93	1.0028	1.2244
Whidbey Island, NAS	47 14.3	67	1.0052	1.0528

Table 11110-2. Runway Temperature and Altitude Corrections (Continued)

Installation	Elevation (feet/meters)	Mean Highest daily temp. hottest month (Deg. F)	Altitude Correction Factor	Temperature Correction Factor
Whitehouse, NOLF	99 / 30.2	91	1.0109	1.2112
Whiting Field (North)	200 / 61.0	92	1.022	1.2178
Willow Grove, NAS JRB	362 / 110.4	87	1.0398	1.1848
Wolf, NOLF	61 / 18.6	91	1.0067	1.2112
Yuma, MCAS	213 / 64.9	107	1.0238	1.3168

Note: (1) Expeditionary airfields – exempt from P-80.3 criteria.

111 12 RUNWAY/FIXED WING - UNSURFACED (M2/SY)

FAC: 1114

BFR Required: Y

Design Criteria: UFC 3-260-01, Airfield and Heliport Planning and Design

Planning Criteria: NAVFAC P-80.3, Facility Planning Factor Criteria for Navy and Marine Corps Shore Installations; Appendix E, Airfield Safety Clearances, UFC 3-260-01, Airfield and Heliport Planning and Design

11112-1 DESCRIPTION. Runways for rotary wing aircraft that do not consist of a pavement or hardstand surface. More specific planning criteria is planned for development.

111 15 RUNWAY/ROTARY WING (M2/SY)

FAC: 1112

BFR Required: Y

Design Criteria: UFC 3-260-01, Airfield and Heliport Planning and Design

Planning Criteria: NAVFAC P-80.3, Facility Planning Factor Criteria for Navy and Marine Corps Shore Installations; Appendix E, Airfield Safety Clearances, UFC 3-260-01, Airfield and Heliport Planning and Design

11115-1 DESCRIPTION. Runways/rotary wing are prepared surfaces for the landing and takeoff of helicopters. For planning purposes, helicopter landing/takeoff surfaces greater than 121.9 meters (400 feet) in length shall be considered a runway. Pavements equal to or less than 121.9 meters (400 feet) in length and-width (or diameter) shall be classified as Category Code 111 20, Helicopter Landing Pad. See UFC 3-260-01, Airfield and Heliport Planning and Design for planning and design criteria and NAVFAC P-80.3, Facility Planning Factor Criteria for Navy and Marine Corps Shore Installations; Appendix E, Airfield Safety Clearances for airfield safety clearances.

11115-2 CRITERIA. The basic rotary wing runway described below is designed to support normal takeoff and landing operations and may be increased in length when training exercises are to be conducted from the runway. Due to the multiple missions assigned to helicopters and the flexibility of their operating methods, standard size training pavements are difficult to define. However, a 305 meter (1,000 foot) long runway (no temperature and altitude correction is applied) is considered sufficient to conduct proficiency training and autorotation exercises for most Navy air installations.

11115-2.1 Width. The standard width for rotary wing runways is 22.9 meters (75 feet). Rotary wing runways which support CH-53 or any helicopter with rotor diameter greater than 21.3 meters (70 feet) shall have a width of 30.5 meters (100 feet).

11115-2.2 Length. The basic rotary wing runway length is 487.8 meters (1,600 feet) corrected for elevation and temperature. For facilities constructed prior to November 2001, the basic rotary wing runway length is 137.2 meters (450 feet).

- a. Altitude Correction. Altitude correction. Increase the rotary wing runway length by 10 percent for each 305 meters (1,000 feet) the runway elevation is above 610 meters (2,000 feet) Mean Sea Level (MSL).
- b. Temperature Correction. Increase the rotary wing runway length by 4.0 percent for each 10°F that the average daily maximum temperature for the hottest month is above 59°F.

11115-3 MULTIPLE TOUCHDOWN POINTS. Where multiple touchdowns points are provided on a single rotary wing runway, the touchdown points shall be spaced a minimum of 121.9 meters (400 feet) center to center.

11115-4 RUNWAY CONFIGURATIONS. Multiple rotary wing runway configurations that may be planned include parallel runways or arranging three runways as each side of a triangle. Distance between centerlines of Parallel Rotary Wing Runways (Visual Flight Rules (VFR) without intervening parallel taxiway between centerlines is a minimum of 213.4 meters (700 feet).

11115-5 DISTANCE FROM CENTERLINE. Distance from the centerline of a Fixed Wing Runway to the centerline of a parallel Rotary Wing Runway under various conditions is as follows:

- a. Simultaneous VFR operations for Class A Runway = 213.4 meters 700 feet)
- b. Simultaneous VFR operations for Class B Runway = 305 meters (1,000 feet)
- c. Instrument Flight Rules (IFR) using simultaneous operations (depart-depart or depart-approach) = 762.2 meters (2,500 feet)
- d. IFR using simultaneous approaches = 1,311 meters (4,300 feet)

11115-6 IFR OPERATIONS. For rotary wing runways designed for IFR operations, the runway design must take into account the Ground Control Approach (GCA) system

to be used and the number of instrumented touchdown points required. For example, two touchdown points located at opposite ends of a 305 meter (1,000 foot) runway could be served by a single GCA located on a turn table offset near the mid point of the runway.

11115-7 AIRCRAFT SAFETY CLEARANCES. The location of objects adjacent to rotary wing runways is governed by the runway primary surface, transitional surface, and approach/departure surface. These surfaces differ for IFR and VFR operations and are defined in NAVFAC P-80.3. Also see P-80.3 for takeoff safety zone criteria for VFR rotary runways.

111 20 HELICOPTER LANDING PAD/HOVERPOINT (M2/SY)

FAC: 1112

BFR Required: Y

Design Criteria: UFC 3-260-01, Airfield and Heliport Planning and Design

Planning Criteria: NAVFAC P-80.3, Facility Planning Factor Criteria for Navy and Marine Corps Shore Installations; Appendix E, Airfield Safety Clearances, UFC 3-260-01, Airfield and Heliport Planning and Design

11120-1 DESCRIPTION. A helicopter landing pad (helipad) is a prepared area for the hovering, vertical takeoff and landing (VTOL) of helicopters and other VTOL aircraft. The pad is designed to accommodate only one helicopter/VTOL aircraft at a time. The pad may service a hospital, administrative activity, command headquarters or other installations which require helicopter cargo or passenger service. Helipads may be planned at fixed wing air installations, but only if air traffic density or safety requirements preclude the use of the fixed wing runways by helicopters. See UFC 3-260-01 for design criteria.

11120-2 HOVERPOINT. A hoverpoint is a prepared and marked surface used as a reference or control point for air traffic control purposes by arriving or departing helicopters. A hoverpoint is generally located in non-traffic areas. See UFC 3-260-01 for design criteria.

11120-2.1 Types of Helipads.

- a. Standard VFR Helipad. VFR standards are used when no permanent requirement exists or will exist in the future for an IFR helipad.
- b. Limited Use Helipad. This is a VFR helipad used at sites where only occasional operations are conducted. These sites may be, but are not limited to, hospitals, headquarter areas, missile sites, and established airfields or heliports where the Limited Use Helipad may be used to preclude mixing helicopters and fixed-wing traffic. Limited Use Helipads may also be used to separate lighter helicopter (12,500 lbs (5,670 kg) or less) from medium and heavy helicopter traffic.
- c. IFR Helipad. IFR standards are used when an instrument approach capability is essential to the mission and no other instrument landing

facilities, either fixed wing or rotary wing, are located within an acceptable commuting distance to the site.

11120-3 HELIPAD LOCATION. Helipad location should be selected with regard to mission requirements, overall facility development, approach-departure surfaces, and local wind conditions. When a helipad is to be located near fixed and rotary wing runways, its location should be based on type of operations. Construction of helipads on buildings or on any type of elevated structure above ground shall be subject to review and approval by Naval Air Systems Command.

11120-4 STAND-BY PARKING. At individual helipad sites where it is necessary to have one or more helicopters on standby, an area adjacent to the helipad, but clear of the landing approach and transitional surfaces, should be designated for standby parking. This area is designated as a parking apron (see Category Code 113 20, Aircraft Parking Apron)

11120-5 SAME DIRECTION INGRESS/EGRESS. Helipads with same direction ingress/egress allow a helicopter pad to be located in a confined area where approach-departures are made from only one direction. The approach may be either VFR or IFR. Same direction ingress/egress helipads must be individually justified and approved by NAVAIRSYSCOM. See UFC 3-260-01, Airfield and Heliport Planning and Design for typical same direction ingress/egress helipad.

11120-6 CRITERIA. The standard helipad is 30.5 meters by 30.5 meters (100 feet by 100 feet) (930.3 square meters (1,100 square yards)) for both Visual Flight Rule (VFR) and Instrument Flight Rule (IFR) operations. The size may be modified to accommodate specific training or mission requirements, for example, a shipboard-sized pad (approximately 15.2 meters by 15.2 meters (50 feet by 50 feet) for shipboard landing practice. Individual justification must be provided. Where more than one helicopter is to be at the pad location at one time, a connecting taxiway and parking apron is required. Helipads at VTOL training air stations (helipads servicing VTOL aircraft) should be 61.0 meters by 91.4 meters (200 feet by 300 feet) (5,575.4 square meters (2,222 square yards)). The standard hoverpoint is 9.1 meters (30 feet) in diameter.

11120-7 AIRFIELD SAFETY CLEARANCES. The location of objects adjacent to helipads and hoverpoints is governed by the primary surface, take off safety zone, transitional surface and approach departure surface. These surfaces differ for IFR and VFR operations and are defined in NAVFAC P-80.3, Airfield Safety Clearance and UFC 3-260-01, Airfield and Heliport Planning and Design.

111 25 FIXED WING AIRCRAFT (VTOL) LANDING PAD

FAC: 1111

BFR Required: Y

11125-1 DESCRIPTION. No criteria are currently available for this category code. It is currently being developed and will be updated as soon as it is complete.

111 30 RUNWAY OVERRUN-PAVED SURFACE (M2/SY)

FAC: 1113

BFR Required: Y

111 30 RUNWAY OVERRUN – PAVED SURFACED (M2/SY)

Design Criteria: UFC 3-260-01, Airfield and Heliport Planning and Design
 UFC 3-260-02, Pavement Design for Airfields

Planning Criteria: NAVFAC P-80.3, Facility Planning Factor Criteria for Navy and Marine Corps Shore Installations; Appendix E, Airfield Safety Clearances, UFC 3-260-01, Airfield and Heliport Planning and Design

11130-1 DESCRIPTION. Runway overruns are areas extending at each end of a runway. The runway overrun areas are required to reduce serious damage to an aircraft in the event that the aircraft runs off of the runway end during takeoff or landing. These overrun areas are sometimes paved or unpaved. It is recommended that the areas be paved to provide a more stable surface to support aircraft wheel loads.

11130-2 CRITERIA. Table 11130-1 provides the dimensional requirements for the overrun areas for Class A and Class B runways.

Table 11130-1 Runway Overruns					
Item		Class A Runway	Class B Runway	Remarks	
No.	Description	Requirement			
1	Length (paved)	300 m (1,000 ft)		Navy and Marine Corps airfields At outlying fields for T-34 aircraft, the required overrun length is 150 m (500 ft).	
2	Total width of overrun (paved)	Sum of runway and shoulders		The outside edges of the overrun, equal in width to the runway shoulder are graded, but not paved.	
3	Paved overrun	Same as width of runway		Center on runway centerline extended to length of the overrun	
4	Longitudinal centerline grade	First 60 m (200 ft) same as last 300 m (1,000 ft) of runway. Remainder: 1.5 percent Maximum	First 90 m (300 ft) same as last 900 m (3,000 ft) of runway. Remainder: 1.5 percent Maximum	To avoid abrupt changes in grade between the first 90 m (300 ft) and remainder of overrun of a Class B runway, the maximum change of grade is 2.0 percent per 30 linear m (100 linear ft.).	
5	Transverse grade	Minimum 2.0 percent Maximum 3.0 percent 40 mm (1.5 in) drop-off At edge of paved overrun +/- 13 mm (0.5 in)		From the centerline of the overrun; Transition from the runway and runway shoulder grades to the overrun grades to be made within the first 45 m (150 ft) of overrun.	

112 AIRFIELD PAVEMENTS – TAXIWAYS

112-1 DESCRIPTION. This basic category covers aircraft taxiway pavements and includes both normal and high speed runway exits. Criteria for peripheral and interior taxi lanes of aircraft parking aprons are included in Category Code 113 20, Aircraft Parking Apron.

112 10 TAXIWAY (M2/SY)

FAC: 1121

BFR Required: Y

Design Criteria: UFC 3-260-01, Airfield and Heliport Planning and Design

Planning Criteria: NAVFAC P-80.3, Facility Planning Factor Criteria for Navy and Marine Corps Shore Installations; Appendix E, Airfield Safety Clearances; UFC 3-260-01, Airfield and Heliport Planning and Design

11210-1 DESCRIPTION. Taxiways are paved surfaces on which aircraft, both fixed and rotary wing, move under their own power to and from landing, service and parking areas. Criteria for surfaces for towing aircraft are included in Category Code 116 50, Towway.

11210-2 TAXIWAY TYPES.

11210-2.1 Basic. The basic airfield layout consists of a taxiway connecting the center of the runway with parking apron. This system limits the number of aircraft operations at an airfield. Departing aircraft must taxi on the runway to reach the runway threshold. When aircraft are taxiing on the runway, no other aircraft is allowed to use the runway. If runway operations are minimal or capacity is low, the basic airfield layout with one taxiway may be an acceptable layout.

11210-2 Parallel Taxiway. A taxiway parallel for the length of the runway, with connectors to the end of the runway and parking apron, is the most efficient taxiway system. Aircraft movement is not hindered by taxiing operations on the runway and the connectors permit rapid entrance and exit to traffic.

11210-2.3 High Speed Taxiway Turnoff. High speed taxiway turnoffs are located intermediate of the ends of the runways to increase the capacity of the runway. The high-speed taxiway turnoff enhances airport capacity by allowing aircraft to exit the runways at a faster speed than turnoff taxiways allow.

11210-2.4 Additional Types of Taxiways. Besides the types of taxiways above, there are other taxiways at an airfield. Taxiways are often referred to based on their function. Common airfield taxiways include, but are not limited to, crossover, connecting, bypass, acute angle, intermediate, and ladder.

11210-2.5 Peripheral and Interior Taxilanes. A taxi route through or around an apron is referred to as a taxilane. Taxilanes are generally an integral part of the

aircraft parking apron and as such as included under Category Code 113 20, Aircraft Parking Apron.

11210-3 CRITERIA. The length of a taxiway depends upon the specific airfield configuration and layout of support facilities. Taxiways are normally 22.9 meters (75 feet) wide. For taxiways which only support Class "A" fixed wing runways or helicopter landing pavements, the taxiway width shall be reduced to a 12.2 meters (40 feet). (See Code 110 introduction for a definition of Class A and B fixed wing runways.) Runway exits are part of the taxiway system and include end, normal intermediate and high-speed turn-offs.

11210-4 EXITS FOR CLASS B FIXED WING RUNWAYS: End turn-offs are planned for each runway end and are 45.7 meters (150 feet) wide, except those from parallel runways to the parallel taxiway which are 61 meters (200 feet) wide. Normal intermediate turn-offs are required for all runways. They are 22.9 meters (75 feet) wide and are placed 610 meters (2,000 feet) from each end of the runway and in the remaining runway length at intervals of not more than 915 meters (3,000 feet) or less than 610 meters (2,000 feet). High-speed turn-offs are provided where traffic studies indicate the requirement. High-speed turn-offs are 30.5 meters (100 feet) wide at the throat tapering to 22.9 meters (75 feet) and are a minimum of 305 meters (1,000 feet) long.

11210-5 EXITS FOR CLASS A FIXED WING RUNWAYS AND ROTARY WING RUNWAYS: End turn-offs and intermediate taxiways shall be 12.2 meters (40 feet) in width.

11210-6 SAFETY CLEARANCES/SEPARATIONS: Taxiways are located so as to provide adequate clearance between taxiing aircraft and aircraft in adjacent areas and obstacles. The following separation clearances apply to the siting of taxiways. The use of separations less than specified requires a waiver from the Naval Air Systems Command. The minimum clearance from the centerline of the fixed wing taxiway to:

	Class "A" Fixed Wing Runway	Class "B" Fixed Wing Runway
Centerline of Parallel Runways	152.4 meters (500 feet)	152.4 meters (500 feet)
Centerline of Parallel Taxiways	53.3 meters (175 feet)	72.4 meters (237.5 feet) or wingspan + 15.2 meters (50 feet), whichever is greater
Edge of Parking Apron	30.5 meters (100 feet)	45.7 meters (150 feet) (1) (2)
Obstacles (fixed or mobile)	45.7 meters (150 feet) (3)	45.7 meters (150 feet)

- Note:
- (1) The parking apron must be sited outside the runway primary surface. Because of this requirement, the apron will normally be a greater distance than 45.7 meters (150 feet) from the parallel taxiway of a Class "B" fixed wing runway.
 - (2) Under certain conditions, a through taxiway may be incorporated within the parking apron as a peripheral taxiway. See the paragraph titled "Deviation for Criteria", Category Code 113 20 (Aircraft Parking Apron).
 - (3) Reduce to 30.5 meters (100 feet) along rotary wing taxiways.

See UFC 3-260-01, Airfield and Heliport Planning and Design for design criteria related to taxiway grades and shoulders.

113 AIRFIELD PAVEMENTS – APRONS (INCLUDES AIRCRAFT PARKING AND ACCESS APRONS)

113 20 AIRCRAFT PARKING APRON (M2/SY), REVISED NOV 2011

FAC: 1131

BFR Required: Y

Design Criteria: UFC 3-260-01, Airfield and Heliport Planning and Design

Planning Criteria: NAVFAC P-80.3, Facility Planning Factor Criteria for Navy and Marine Corps Shore Installations; Appendix E, Airfield Safety Clearances; UFC 3-260-01, Airfield and Heliport Planning and Design

11320-1 DESCRIPTION. Aircraft parking aprons are required for loading, unloading and servicing of aircraft in addition to providing parking space. There is no standard size or apron configuration. The size is based on the type and number of aircraft to be parked, the requirement for squadron integrity and 45 versus 90 degree parking. The area required includes: parking space, wing-tip separation between aircraft, interior taxilanes and peripheral taxilanes. Aprons used for ordnance handling require special siting considerations, see Category Codes 116 55, Ordnance Handling Pad and 116 56, Combat Aircraft Ordnance Loading Area. For design criteria, see UFC 3-260-01, Airfield and Heliport Planning and Design.

11320-2 CRITERIA. In some cases, these criteria will refer to standards for aprons supporting Class A or B aircraft. (See section 110 introduction for explanation of Class A and B standards.) The determination of the apron requirement involves the following steps:

1. Determine the number of aircraft parking spaces required.
2. Layout the parking spaces using the dimensions given herein for clearances between aircraft and interior taxilanes.
3. Provide peripheral taxiways around the perimeter of the apron.

11320-3 NUMBER OF PARKING SPACES. The number of parking spaces required is based on the average number of aircraft on-board (including transients) reduced by a factor to reflect the number of aircraft expected to be in hangars for scheduled organizational maintenance. For planning purposes, assume that the following percentages of the average on-board aircraft assigned organizational maintenance at a station will be in the hangar for scheduled maintenance:

- 33% - Carrier and Rotary Wing aircraft
- 17% - Patrol, Special Mission, and Training aircraft
- 11% - Transport aircraft

11320-3.1 The above reductions apply except that the reduction to the number of apron parking spaces shall not exceed 50 percent of the hangar spaces available.

11320-3.2 Where organizational maintenance is provided by a commercial contractor, the average number of aircraft in hangars for scheduled maintenance shall be determined on an individual basis. Where an air installation is subject to peak loadings on a regular basis for training exercises or overlap of deployable squadrons, individual justification may be provided for additional spaces to support peak loadings.

11320-3.3 Example Computation: A station supports 6 fleet operational F/A-18 squadrons. Each squadron has 12 aircraft. Determine the number of parking apron spaces required.

- a. F/A-18 aircraft are categorized as Carrier aircraft.
- b. Total number of aircraft = $6 \times 12 = 72$
- c. Reduction for aircraft assigned organizational maintenance (i.e. parked in aircraft maintenance hangar) (for Carrier aircraft) = $72 \times 33\% = 23.8 = 24$ (rounded to next whole number). However, the reduction shall not exceed 50% of the aircraft maintenance hangar space available. Therefore, the total reduction for aircraft assigned organizational maintenance (i.e. parked in aircraft maintenance hangar) = $24 \times 50\% = 12$
- d. Number of aircraft requiring apron parking apron spaces = $72 - 12 = 60$

11320-4 SPACING OF AIRCRAFT. The following Tables and Figures provide dimensions for apron spacing and typical apron configurations:

Table 11320-1 – Parking Apron Spacing – Jet Aircraft: 45 Degree Parking
 Table 11320-2 – Parking Apron Spacing – Jet Aircraft: 90 Degree Parking
 Table 11320-3 – Parking Apron Spacing – Propeller Aircraft: 90 Degree Parking
 Table 11320-4 – Parking Apron Spacing – Helicopters: 90 Degree Parking
 Figure 11320-1 – 90-Degree Aircraft Parking Configuration
 Figure 11320-2 – 45-Degree Aircraft Parking Configuration
 Figure 11320-3 – Typical Aircraft Parking Apron
 Figure 11320-4 – Aircraft Parking Apron, Fixed Wing Aircraft, Minimal Through Traffic
 Figure 11320-5 – Minimum Peripheral Taxilane, Fixed Wing Aircraft

11320-4.1 Jet Blast Protection. Parked aircraft must be separated to maintain proper wing-tip clearances, interior taxilane widths and protection from jet blast. Jet blast protection is achieved by providing the space necessary to dissipate the temperature and velocity of the jet blast to levels that will not injure or damage aircraft personnel and equipment. Typically, this level is approximately 100 degrees

Fahrenheit (38 degrees Celsius) and 30.4 knots (35 mph). This level can be easily achieved by parking carrier based aircraft at 45 degrees with their engine blast aimed into the interior taxilane, providing safe and adequate jet blast dispersion (see Table 11320-1 and Figure 11320-2).

11320-4.2 Deviations from Efficient Configuration. The most efficient apron size results from parking jet aircraft at either a 45-degree or 90-degree angle, and propeller aircraft and helicopters at a 90-degree angle to the interior taxilane. Use of the most efficient configuration is preferred. Factors impacting designs for aircraft parking configurations could include space availability, operational constraints, type and number of aircraft, taxiing or towing procedures, and clearances. See Figures 11320.1 and 11320.2 for the 45 and 90-degree configurations and the description of the A, B, C, D and E dimensions used for apron spacing. Tables 11320.1, Table 11320.2, Figure 11320.3 and Figure 11320.4 provide the spacing dimensions, which shall be used for Basic Facility Requirements determination. The apron spacing dimensions may be modified when a Fixed Point Utility System (FPUS), starting air and electrical service, or Flightline Electrical Distribution System (FLEDS), electrical system is to be installed in the apron. The FPUS or FLEDS service points and the parking spaces are spaced to accommodate all Navy fighter and attack aircraft rather than designed for a particular aircraft. Aprons with FPUS or FLEDS may be planned using an "A + D" dimension of 44.2 meters (145 feet) and a "C" dimension of 21.6 meters (71 feet), assuming 45 degree parking. For aprons which are expected to support S-3 aircraft, the "A + D" may be increased to 45.7 meters (150 feet).

11320-5 PERIPHERAL TAXILANES. A peripheral taxilane is normally provided on all sides of an aircraft parking apron. The MC-4 Triton does not require peripheral taxilane. Movement of this aircraft in and out of hangar and inside an apron is achieved with a towing tractor. The standard width is 45.7 meters (150 feet) except for those aprons which support only helicopters and no future requirement to support fixed wing aircraft can be identified. In this case the width shall be computed as:

$$\text{Width} = 1.5 \times (\text{Rotor Diameter}) + 6.1 \text{ meters (20 feet)}$$

11320-5.1 Use the largest rotor diameter of those helicopters expected to use the apron. This width provides a 12.2 meter (40 foot) taxilane with a one rotor diameter clearance between taxiing and parking helicopters.

11320-6 SAFETY/LATERAL CLEARANCES. See NAVFAC P-80.3, Airfield Safety Clearances and UFC 3-260-01, Airfield and Heliport Planning and Design for the definition and application of airfield safety clearances. Parking aprons shall be sited outside the primary surface of the runway (or helipad). The edge of the apron may be adjacent to the outer edge of the primary surface, however, parked aircraft shall not penetrate the transitional surface.

11320-7 DISTANCE FROM APRON EDGE. Aircraft taxiing on the peripheral taxilane are not considered obstructions even though they do penetrate the transitional surface. The apron edge shall be a minimum of 45.7 meters (150 feet) from the

centerline of any parallel taxiway of the runway system. The minimum distance any object, except maintenance hangars, shall be sited from the apron edge is:

- a. for Class "A" aircraft aprons: 22.9 meters (75 feet)
- b. for Class "B" aircraft aprons: 30.5 meters (100 feet)
- c. for Helicopters aprons: 22.9 meters (75 feet) (Note: increase to 30.5 meters (100 feet) where the CH-53 is assigned to an apron)

11320-8 MAINTENANCE HANGAR OFFSET FROM APRON. Maintenance hangars opening to the apron shall be offset 15.2 meters (50 feet) from the apron edge. For criteria for this 15.2 meter (50 foot) access pavement to the hangar see Category Code 113-40, Aircraft Access Apron.

11320-9 DEVIATION FROM CRITERIA: The 45.7 meter (150 foot) separation between an aircraft parking apron and the centerline of a through taxiway must be maintained when the taxiway is expected to carry a substantial amount of through traffic; i.e., traffic other than that which starts or terminates at that particular apron. When the anticipated amount of through traffic is minimal and is so justified to NAVAIRSYSCOM, a parking apron may be located such that the through taxiway is incorporated within the apron peripheral taxilane, see Figure 11320.4. However, in this case, the through taxiway becomes a part of the apron and therefore must be located outside the runway primary surface. Any savings in pavement to be gained by combining taxiways shall be compared to any increases in pavement for runway turnoffs required due to moving the parallel taxiway outside the runway primary surface. Combined taxiways shall not be planned without prior approval of NAVAIRSYSCOM.

11320-10 Figure 11320-3 indicates that 45.7 meter (150 foot) wide peripheral taxilanes are to be provided on all sides of fixed wing aircraft parking aprons. Although such an arrangement is desirable, it is not always necessary. When small numbers of aircraft (one or two rows) are to be parked or when operational requirements allow, the number and/or width of the peripheral taxilanes may be reduced on the advice of local air operations personnel, subject to NAVAIRSYSCOM approval. See Figures 11320-3/11320-4 which indicate which fixed wing aircraft peripheral taxilanes may be reduced. The 45.7 meter (150 foot) wide taxilane is designed to accommodate two carrier type aircraft when passing and therefore could be reduced in width if the level of apron operations only require one aircraft to be on the taxilane at a time. In this case, the taxilane shall be sized to accommodate the largest aircraft to be parked on the apron. See Figure 11320-5 which provides a sketch of the minimum taxilane clearances. Peripheral taxilanes for helicopters shall not be reduced from the dimensions shown in Table 11320-1.

11320-11 Tables 11320-1, 11320-2, 11320-3 and 11320-4 list aircraft by type and include all models, such as the S-3 aircraft type which includes S-3A, S-3B, ES-3A, US-3A, and YS-3A. However, in some instances there are size differences between models of the same aircraft, such as the F/A-18A and the F/A-18E. In these cases, the particular aircraft type is also further defined by the model to which the data applies.

Table 11320-1. Parking Apron Spacing Jet Aircraft: 45 Degree Parking

Aircraft Type	Wingspan		Length		A	B	C	D	E
	(ft/in)	(m)	(ft/in)	(m)	(ft/m)	(ft/m)	(ft/m)	(ft/m)	(ft/m)
A-4	27' 6"	8.38	39' 5"	12	31/9.5	31/9.5	53/16.1	90/27.4	150/45.7
A-6	53' 0"	16.1	54' 6"	16.6	47/14.3	47/14.3	96/29.3	90/27.4	150/45.7
A-7	40' 4"	12.3	56' 0"	17.1	39/11.9	39/11.9	71/21.6	90/27.4	150/45.7
AV-8	30' 4"	9.2	46' 4"	14.1	36/11	36/11	57/17.4	90/27.4	150/45.7
EA-6B	53' 0"	16.1	59' 10"	18.2	47/14.3	47/14.3	96/29.3	90/27.4	150/45.7
F-35B	35' 0"	10.7	51' 3"	15.6	45/13.7	45/13.7	65/19.8	141/43.0	150/45.7
F-35C	43' 0"	13.1	51' 4"	15.6	47/14.3	47/14.3	65/19.8	141/43.0	150/45.7
F-4	38' 5"	11.7	58' 3"	17.7	47/14.3	47/14.3	70/21.3	90/27.4	150/45.7
F-5E	28' 0"	8.5	48' 3"	14.6	-2	-2	-2	-2	150/45.7
F-5F	28' 0"	8.5	51' 8"	15.5	-2	-2	-2	-2	150/45.7
F-14	64' 2"	19.5	62' 8"	19.1	56/17.1	56/17.1	106/32.3	95/28.9	150/45.7
F-14(1)	38' 3"	11.7	62' 8"	19.1	55/17.1	55/17.1	70/21.3	90/27.4	150/45.7
F/A-18A,B,C,D	40' 5"	12.3	56' 0"	17.1	47/14.3	47/14.3	71/21.6	90/27.4	150/45.7
F/A-18E,F	44' 9"	13.6	60' 2"	18.3	51/15.5	51/15.5	71/21.6	90/27.4	150/45.7
S-3	68' 8"	20.9	53' 3"	16.2	51/15.5	51/15.5	114/34.7	99/30.2	150/45.7
C-5	222' 9"	67.9	247' 11"	74.9	199/60.6	199/60.6	350/107	273/83.2	150/45.7
C-9	93' 4"	28.4	119' 4"	36.4	97/29.6	97/29.6	160/48.8	133/40.5	150/45.7
C-17	170' 0"	51.8	174' 0"	53	-2	-2	-2	-2	150/45.7
C-141A	160' 0"	48.8	145' 0"	44.2	-2	-2	-2	-2	150/45.7
C-141B	160' 0"	48.8	168' 3"	51.3	-2	-2	-2	-2	150/45.7
C-40A									150/45.7
E-6	148' 0"	45.1	150' 0"	45.7	-2	-2	-2	-2	150/45.7
KC-135	130' 10"	39.9	136' 3"	41.5	130/39.6	130/39.6	220/67	181/55.2	150/45.7
T-2	38' 1"	11.6	38' 7"	11.8	40/12.2	40/12.2	90/27.4	90/27.4	150/45.7
T-39	44' 5"	13.6	44' 6"	13.6	38/11.6	38/11.6	90/27.4	90/27.4	150/45.7
T-45	30' 10"	9.4	39' 3"	12	-2	-2	-2	-2	150/45.7

Note: (1) Wing Swept
(2) Contact COMNAVAIRSYSCOM for guidance

Table 11320-2. Parking Apron Spacing - Jet Aircraft: 90 Degree Parking

Aircraft Type	Wingspan		Length		A	B	C	D	E
	(ft/in)	(m)	(ft/in)	(m)	(ft/m)	(ft/m)	(ft/m)	(ft/m)	(ft/m)
A-4	27' 6"	8.38	39' 5"	12	39/11.9	28/8.5	38/11.6	125/38.1	150/45.7
A-6	53' 0"	16.1	54' 6"	16.6	56/17.1	53/16.1	68/20.7	105/32.0	150/45.7
A-7	40' 4"	12.3	56' 0"	17.1	46/14.0	39/11.9	49/14.9	125/38.1	150/45.7
AV-8	30' 4"	9.2	46' 4"	14.1	46/14.0	30/9.1	40/12.2	100/30.5	150/45.7
EA-6B	53' 0"	16.1	59' 10"	18.2	60/18.3	53/16.1	68/20.7	105/32.0	150/45.7
F-35B	35' 0"	10.7	51' 3"	15.6	45/13.7	45/13.7	65/19.8	200/61.0	150/45.7
F-35C	43' 0"	13.1	51' 4"	15.6	47/14.3	47/14.3	65/19.8	200/61.0	150/45.7
F-4	38' 5"	11.7	58' 3"	17.7	58/17.7	38/11.6	48/14.6	115/35.0	150/45.7
F-5E	28' 0"	8.5	48' 3"	14.6	48/14.6	28/8.5	38/11.6	100/30.5	150/45.7
F-5F	28' 0"	8.5	51' 8"	15.5	52/15.8	28/8.5	38/11.6	100/30.5	150/45.7
F-14	64' 2"	19.5	62' 8"	19.1	62/18.9	65/19.8	80/24.4	125/38.1	150/45.7
F-14(1)	38' 3"	11.7	62' 8"	19.1	62/18.9	65/19.8	80/24.4	125/38.1	150/45.7
F/A-18A,B,C,D	40' 5"	12.3	56' 0"	17.1	56/17.1	40/12.2	50/15.2	115/35.0	150/45.7
F/A-18E,F	44' 9"	13.6	60' 2"	18.3	60/18.3	45/13.7	50/15.2	115/35.0	150/45.7
S-3	68' 8"	20.9	53' 3"	16.2	53/16.1	69/21.0	84/25.6	135/38.1	150/45.7
C-5	222' 9"	67.9	247' 11"	74.9	247/75.0	223/68.0	248/75.6	273/83.2	150/45.7
C-9	93' 4"	28.4	119' 4"	36.4	119/36.3	93/28.3	113/34.4	133/40.5	150/45.7
C-17	170' 0"	51.8	174' 0"	53	174/53.0	170/51.8	190/57.9	210/64.0	150/45.7
C-141A	160' 0"	48.8	145' 0"	44.2	168/51.2	161/49.1	186/56.7	211/64.3	150/45.7
C-141B	160' 0"	48.8	168' 3"	51.3	168/51.2	161/49.1	186/56.7	211/64.3	150/45.7
C-40A									
E-6	148' 0"	45.1	150' 0"	45.7	150/45.7	148/45.1	168/51.2	190/57.9	150/45.7
KC-135	130' 10"	39.9	136' 3"	41.5	136/41.4	131/39.9	156/47.5	181/55.2	150/45.7
P-8A	124' 6"	37.9	129' 6"	39.5'	130/39.6	125/38.1	150/45.7	194/59.1	150/45.7
T-2	38' 1"	11.6	38' 7"	11.8	39/11.9	38/11.6	48/14.6	110/33.5	150/45.7
T-39	44' 5"	13.6	44' 6"	13.6	45/13.7	44/13.4	54/16.4	115/35.0	150/45.7
T-45	30' 10"	9.4	39' 3"	12	39/11.9	31/9.5	41/12.5	100/30.5	150/45.7

Note: (1) Wings Swept

Table 11320-3. Parking Apron Spacing Propeller Aircraft: 90 Degree Parking

Aircraft Type	Wingspan		Length		A	B	C	D	E
	(ft/in)	(m)	(ft/in)	(m)	(ft/m)	(ft/m)	(ft/m)	(ft/m)	(ft/m)
C-2	80' 7"	24.6	56' 8"	17.3	57/17.4	81/24.7	101/30.8	121/36.9	150/45.7
C-12	54' 6"	16.6	43' 9"	13.3	44/13.4	55/16.8	70/21.3	90/27.4	150/45.7
C-130	132' 7"	40.4	97' 10"	29.8	98/29.9	133/40.5	158/48.1	183/55.8	150/45.7
E-2	80' 7"	24.6	57' 6"	17.5	56/17.1	81/24.7	101/30.8	121/36.9	150/45.7
P-3	99' 8"	30.4	116' 10"	35.6	117/35.7	100/30.5	120/36.6	150/45.7	150/45.7
T-34	33' 4"	10.1	28' 9"	8.7	29/8.8	33/10.0	43/13.1	90/27.4	150/45.7
T-44	50' 3"	15.3	35' 6"	10.8	36/11.0	50/15.2	65/19.8	90/27.4	150/45.7

Table 11320-4. Parking Apron Spacing Helicopters - 90 Degree Parking

Aircraft Type	Wingspan		Length		A	B	C	D	E(1)
	(ft/in)	(m)	(ft/in)	(m)	(ft/m)	(ft/m)	(ft/m)	(ft/m)	(ft/m)
H-1, except AH-1	48' 0"	14.6	58' 4"	17.8	58' 4"/17.8	48'/14.6	72'/22	120'/36.6	92'/28
AH-1	48' 0"	14.6	58' 3"	17.8	58' 3"/17.8	48'/14.6	72'/22	120'/36.6	92'/28
H-2	44' 0"	13.4	52' 7"	16	52/15.8	44/13.4	66/20.1	110/33.5	86/26.2
H-3	62' 0"	18.9	72' 6"	22.1	73/22.2	62/18.9	93/28.3	124/37.7	113/34.4
H-46	51' 0"	15.5	84' 4"	25.7	84' 4"/25.7	51'/15.5	76' 6"/23.3	102'/31.1	96' 6"/29.4
H-53D	72' 3"	22	88' 3"	25.4	88/26.8	72/21.8	108/32.9	144/34.7	128/39.0
H-53E/K	79' 0"	24.1	99' 0"	30.2	99/30.2	79/24.1	119/36.3	158/48.1	139/42.4
TH-57	33' 4"	10.1	38' 10"	11.8	39/11.9	33/10.0	50/15.2	84/25.6	70/21.3
H-60	64' 10"	19.7	53' 8"	16.3	65/19.8	54/16.4	81/24.7	108/32.9	101/30.8
V-22	84' 6"	25.8	57' 8"	17.6	58'/17.7	85'/26	127'/38.7	170'/52	150'/45.7

Note: (1) The "E" dimension for helicopters is equal to 1.5 x (Rotor Diameter) plus 20 ft.
Therefore, E = 1.5R + 20

Figure 11320- 1: 90 Degree Aircraft Configuration

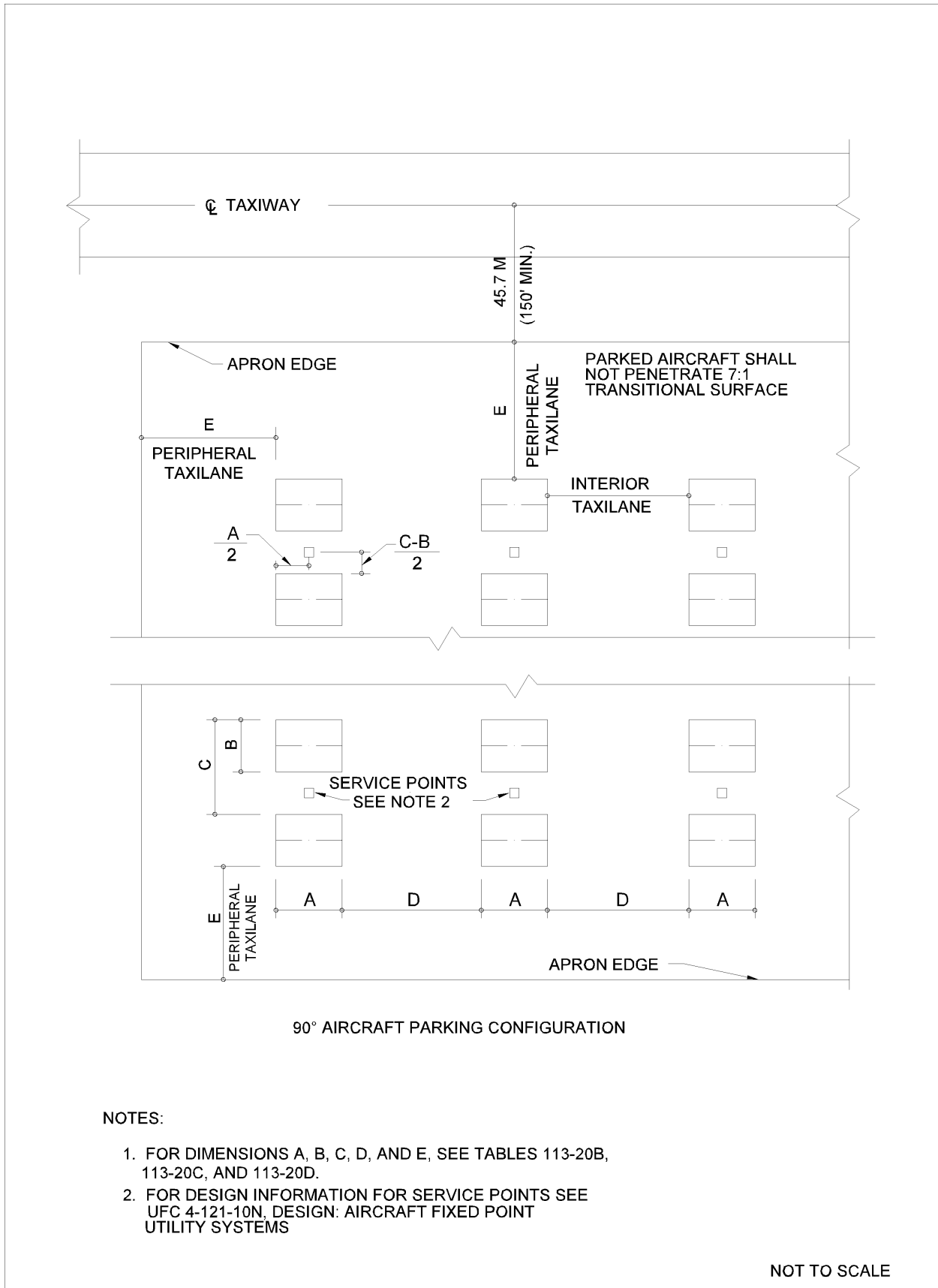

NOTES:

1. FOR DIMENSIONS A, B, C, D, AND E, SEE TABLES 113-20B, 113-20C, AND 113-20D.
2. FOR DESIGN INFORMATION FOR SERVICE POINTS SEE UFC 4-121-10N, DESIGN: AIRCRAFT FIXED POINT UTILITY SYSTEMS

NOT TO SCALE

Figure 11320-2: 45 Degree Aircraft Parking Apron Configuration

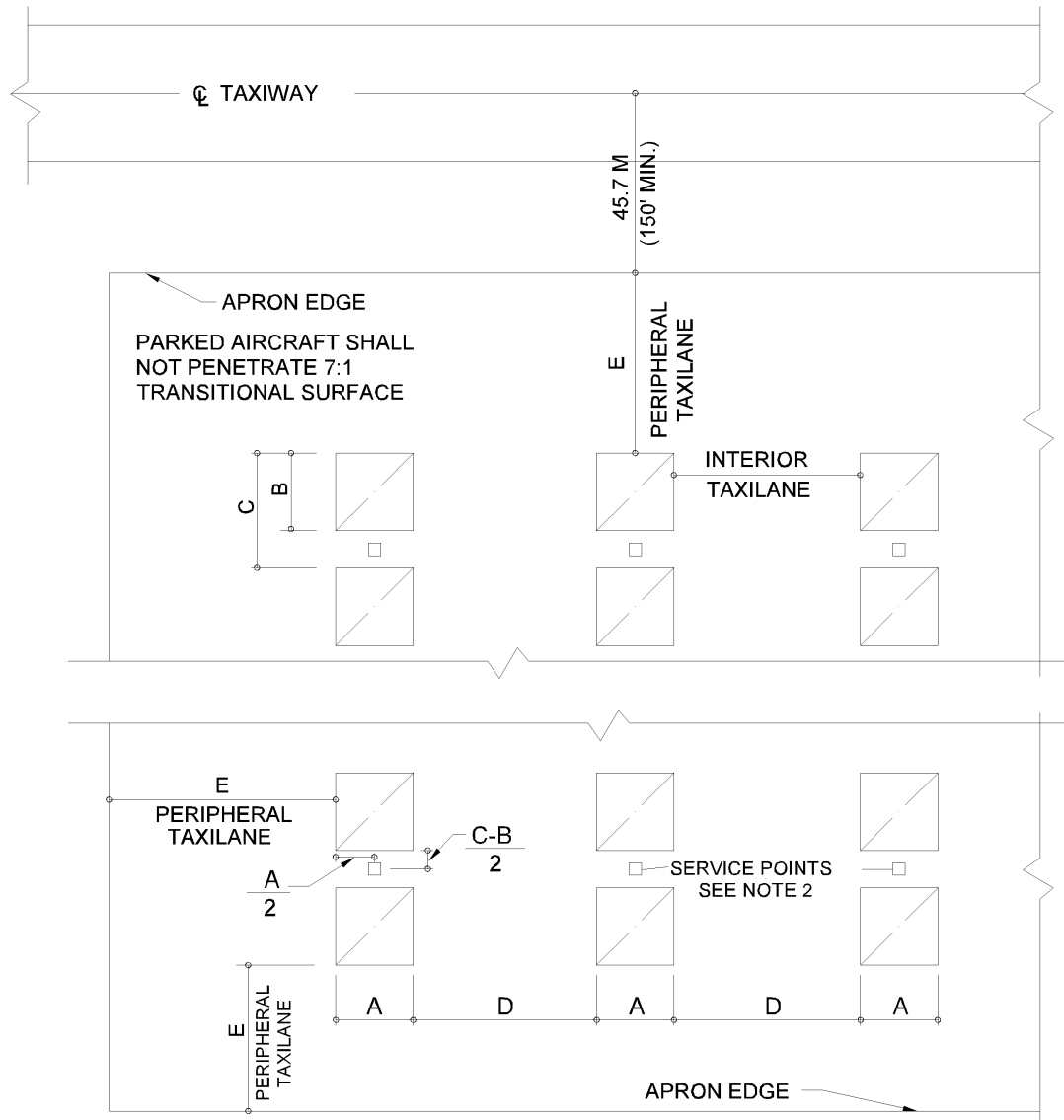

45° AIRCRAFT PARKING CONFIGURATION

NOTES:

1. FOR DIMENSIONS A, B, C, D, AND E, SEE TABLE 113-20A
2. FOR DESIGN INFORMATION FOR SERVICE POINTS SEE UFC 4-121-10N, DESIGN: AIRCRAFT FIXED POINT UTILITY SYSTEMS

NOT TO SCALE

Figure 11320-3: Typical Aircraft Parking Apron

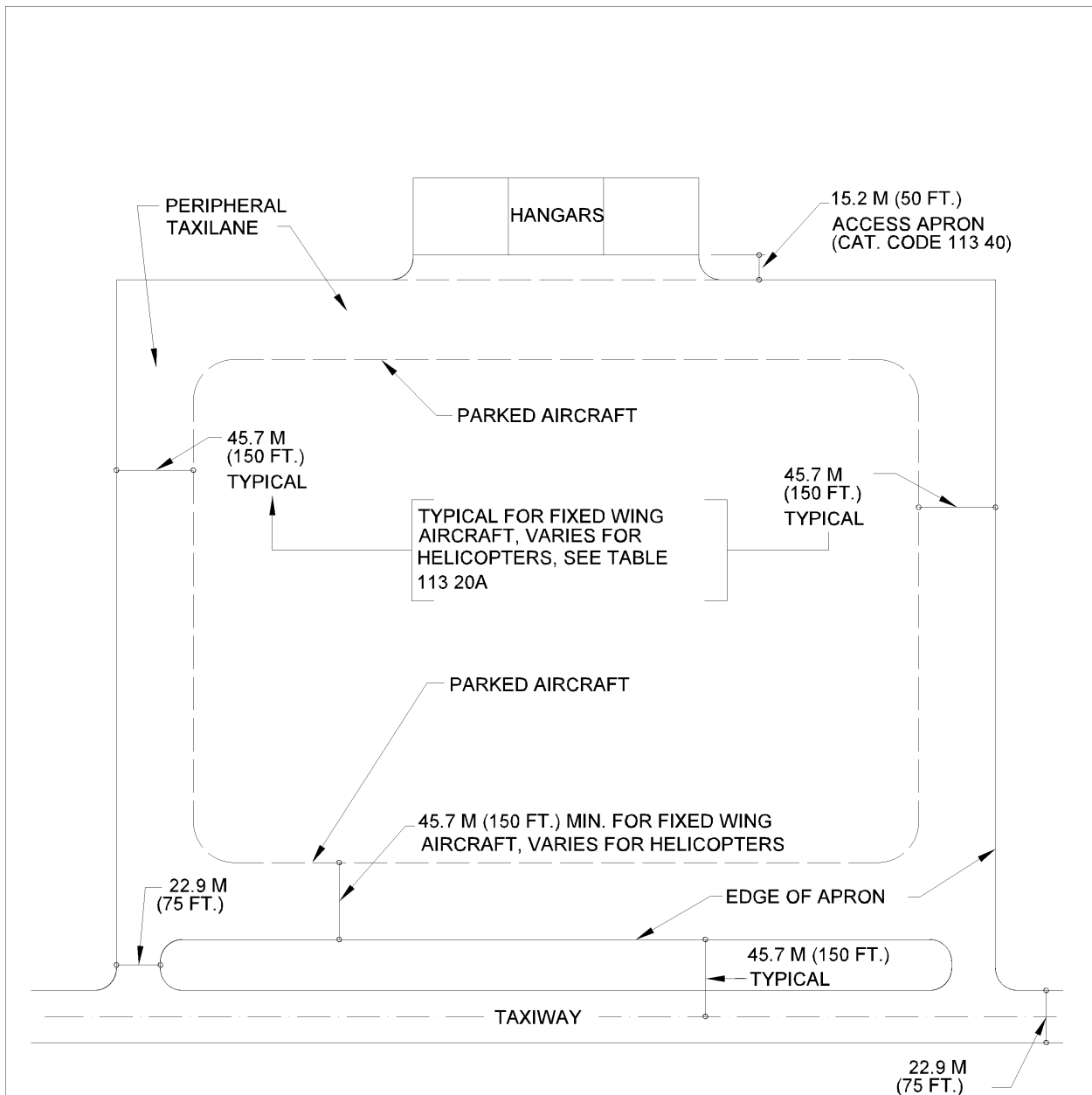

TYPICAL AIRCRAFT PARKING APRON

NOTES:

1. DIMENSIONS MARKED "TYPICAL" MAY BE REDUCED UNDER CERTAIN OPERATING CONDITIONS. SEE PARAGRAPH TITLED "DEVIATIONS FROM CRITERIA".
2. THE EDGE OF THE APRON MUST BE OUTSIDE THE RUNWAY PRIMARY SURFACE, PARKED AIRCRAFT SHALL NOT PENETRATE THE 7:1 TRANSITION SURFACE. (SEE UFC-3-260-01, AIRFIELD AND HELIPORT PLANNING AND DESIGN.)

NOT TO SCALE

Figure 11320-4: Aircraft Parking Apron, Fixed Wing Aircraft, Minimal Through Traffic

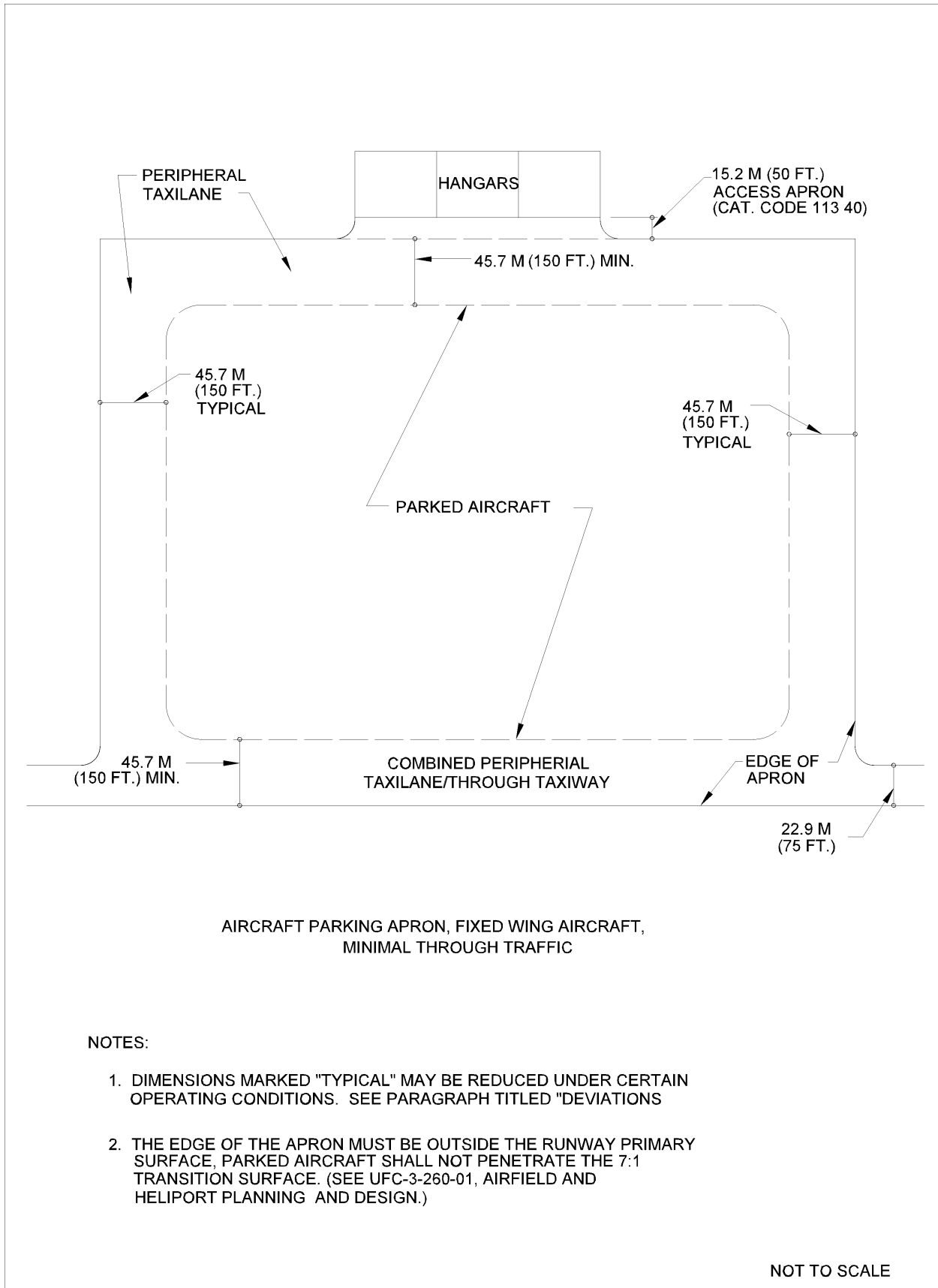
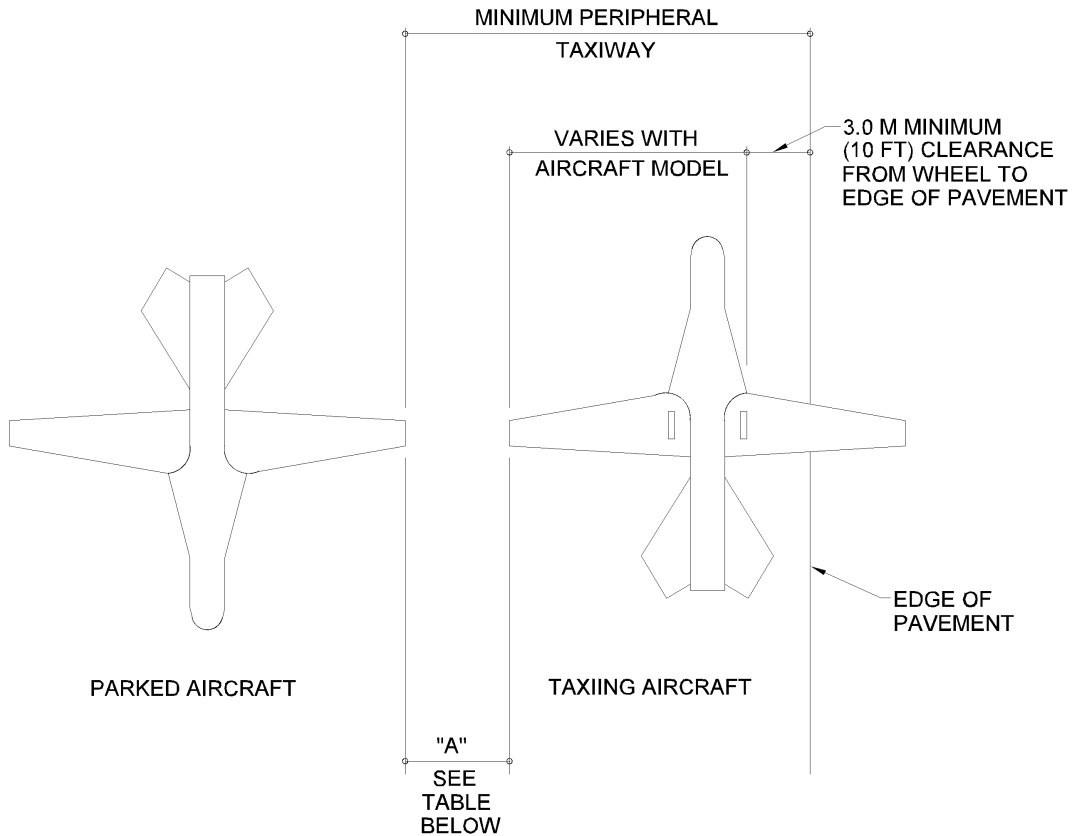

Figure 11320-5. Minimum Peripheral Taxiway, Fixed Wing Aircraft



MINIMUM PERIPHERAL TAXILANE, FIXED WING AIRCRAFT

WINGSPAN OF TAXIING AIRCRAFT	"A" MIN. WINGTIP CLEARANCE
OVER 30.5 M (100 FT.)	7.6 M (25 FT.)
22.9 M TO 30.5 M (75 FT. TO 100 FT.)	6.1 M (20 FT.)
15.2 M TO 22.5 M (50 FT. TO 74 FT.)	4.6 M (15 FT.)
15.2 M (LESS THAN 50 FT.)	3.0 M (10 FT.)

NOT TO SCALE

113 40 AIRCRAFT ACCESS APRON (M2/SY)**FAC: 1131****BFR Required: Y****Design Criteria:** UFC 3-260-01, Airfield and Heliport Planning and Design

11340-1 AIRCRAFT ACCESS APRONS. Aircraft access aprons provide access to aircraft maintenance hangars from the aircraft parking apron and is normally programmed at the same time as the hangar (Category Code 211 05). The paved area required varies with the hangar dimensions and the hangars displacement from the aircraft parking apron. The access apron requires a minimum 15.2 meter (50 foot) depth and must be at least as long as the hangar door.

116 AIRCRAFT PAVEMENTS – OTHER

116-1 DESCRIPTION. Included in this basic category are airfield pavements, other than runways, taxiways, and aprons, such as wash racks, rinse facilities, compass calibration pads, arming/de-arming pads, Ground Controlled Approach (GCA) pads, blast protective pavement, line vehicle parking, tow ways, ordnance handling pads, fire and rescue vehicle alert pads, and tactical support van pads.

116 10 AIRCRAFT WASHRACK PAVEMENT (M2/SY)**FAC: 1163****BFR Required: Y****Design Criteria:** UFC 3-260-01, Airfield and Heliport Planning and Design

11610-1 WASHRACKS. Aircraft wash racks are provided at all air installations for cleaning of aircraft in conjunction with periodic maintenance. See Category Code 116 15 for aircraft freshwater rinse facility criteria. A minimum of one wash rack is required at each Naval and Marine Corps aviation shore installation. The total number required at an installation depends on numbers and types of on-board aircraft. The number of aircraft that can be serviced by a single wash rack is dependent on the frequency of required washes, prescribed in NAVAIR Manual NA01-1A-509, the average time to wash the aircraft, and the availability of the wash rack. The two types of standard wash racks are:

11610-1.1 Type A (for Fighter and Attack Aircraft and Helicopters):

For Navy and Marine Corps Aircraft, (except H-53) 671 square meters (25.9 m x 25.9 m) (803 square yards (85 ft x 85 ft)). H-53 aircraft require 1,116 square meter (30.5 m x 36.6 m) (1,333 square yard (100 ft x 120 ft)).

11610-1.2 Type A wash rack can service 80 VAVF or similar size aircraft or 40 rotary wing aircraft, or a combination of both. The number of combined aircraft that can be serviced on a Type A pad can be determined from the following

equation: The number of VA/VF (or similar size) aircraft plus two times the number of helicopters equals 80.

Example: 40 VA/VF plus 20 helicopters as 40 plus 2(20) does not exceed 80.

11610-1.3 Type B (for Patrol and Cargo Transport Aircraft):

For Navy and Marine Corps aircraft (except E-6) 1,522 square meters (1,822 square yards). E-6 aircraft require 3,173 square meters (3,797 square yards). See Figure 116-10A for typical configuration and dimensions.

11610-1.4 Type B washrack can service 20 VP aircraft or 80 cargo transport aircraft, or a combination of both. The number of combined aircraft that can be serviced on a Type B pad can be determined from the following equation: four times the number of patrol aircraft (VP) plus the number of cargo aircraft equals 80.

EXAMPLE: 18 VP and 8 cargo as 4(18) plus 8 does not exceed 80.

Figure 11610-1: Type B Wash Rack

DIMENSION	ALL NAVY AIRCRAFT EXCEPT E-6	E-6 AIRCRAFT
A	42.7m (140')	61.0m (200')
B	9.2m (30')	10.7m (35')
C	6.1m (20')	4.9m (16')
D	12.2m (40')	29.9m (98')
E	6.1m (20')	10.7m (35')
F	9.1m (30')	4.9m (16')
G	45.8m (150')	57.9m (190')
H	30.5m (100')	45.8m (150')
I	6.1m (20')	4.9m (16')
J	9.2m (30')	7.3m (24')

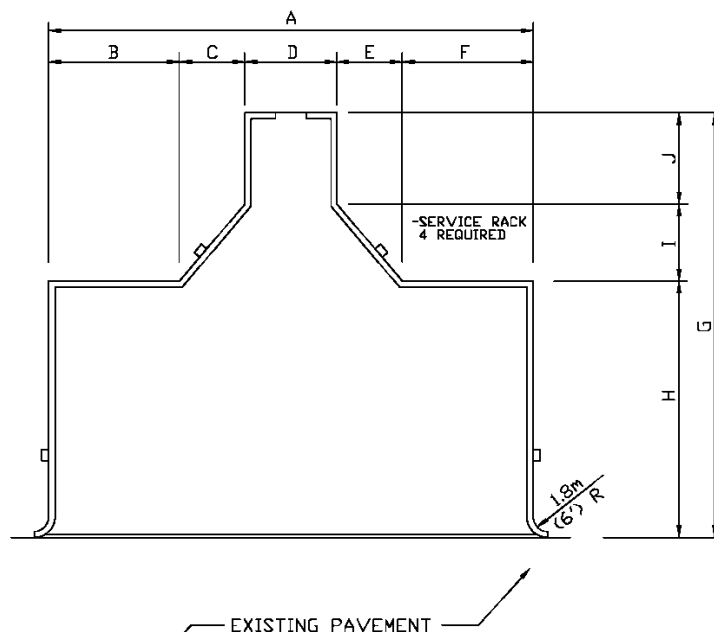

11610-2 WASH RACK LOCATION. The normal location of the wash racks is adjacent to the hangar with access pavement provided as required. Utilities and an antipollution drainage system are provided.

11610-3 ACCOMPANYING UTILITIES. A utilities control building with a gross area of approximately 58.6 square meters (630 square feet) is planned with each wash rack. It houses detergent metering equipment, air compressor, detergent mixing tank, water heater, utility controls, sanitary facilities for personnel, if required, and storage space for cleaning equipment. A detergent storage tank is located outside of the utilities control center and may be below ground.

11610-4 SAFE ACCESS. An aircraft wash rack must include the capability to provide safe access to all aircraft surfaces with lifelines and/or platforms for personnel safety.

11610-5 RUNOFF. In addition, the wash rack pavement must be curbed and guttered to preclude uncontrolled runoff of wash and rinse water. The wash rack pavement must also include adequate runoff storage capacity to preclude overflow of wash and rinse water and average daily rainfall with daily emptying and disposal of effluent in the sump. For VF/VA and helicopter type aircraft this effluent storage capacity shall be not less than 18,900 L (5,000 GA) per day. For VP and transport type aircraft the effluent collection and storage capacity shall be not less than 15,100 L (4,000 GA) per day. For layout and design criteria for wash racks, see UFC 3-260-01.

116 12 AIRCRAFT PAVEMENT SHOULDER (M2/SY)

FAC: 1165

BFR Required: Y

11612-1 DESCRIPTION. No criteria are currently available for this category code.

116 15 AIRCRAFT RINSE FACILITY (M2/SY)

FAC: 1167

BFR Required: Y

Design Criteria: UFC 3-260-01, Airfield and Heliport Planning and Design

Planning Criteria: UFC 3-260-01, Airfield and Heliport Planning and Design

11615-1 TAXI-THROUGH. An aircraft rinse facility provides an unattended taxi-through, treadle operated, freshwater deluge system to rinse aircraft. The aircraft rinse facility is required at each Navy and Marine Corps air installation having aircraft subject to accelerated corrosion due to low-level over-water operations or a corrosive atmosphere at the installation. A facility of appropriate type is planned for each type of aircraft normally stationed at the airfield.

11615-1.1 Type 1 is for rotary wing aircraft and has a gross area of 913.3 M2 (1,093 SY)

- 11615-1.2** Type 2 is for VP type aircraft and has a gross area of 1428.9 M2 (1,710 SY)
- 11615-1.3** Type 3 is for VF or VA type aircraft and has a gross area of 760.4 M2 (910 SY)
- 11615-1.4** Type 4 is for V-22 aircraft and has a gross area of 913.3 M2 (1,093 SY)

11615-2 ACCESS TAXIWAYS AND VEHICLE ROADS. Access taxiways (Category Code 112 10) and vehicle roads (Category Code 851 10) are programmed with the rinse facility as required. The facility should be located in proximity to the most frequently used taxiway and as near to the hangar area as possible. A water supply and drainage area are required.

116 20 AIRCRAFT COMPASS CALIBRATION PAD (M2/SY)

FAC: 1161

BFR Required: Y

Design Criteria: UFC 3-260-01, Airfield and Heliport Planning and Design; Military Handbook 1021/1, Airfield Geometric Design

Planning Criteria: UFC 3-260-01, Airfield and Heliport Planning and Design

11620-1 AIRCRAFT COMPASS CALIBRATION PAD. An aircraft compass calibration pad is a paved area in a magnetically quiet zone where the compass in the aircraft is calibrated. There are two types of calibration pads:

- a. Type I is used with the magnetic compass calibration set.
- b. Type II pad includes a compass rose and turntable and may be used either with or without the compass calibration set.

11620-2 PAD CAPABILITIES. Either pad handles one aircraft at a time. A minimum of one pad is provided at each station, however, additional pads may be required based on local demand. The time required to calibrate one aircraft compass using the magnetic compass calibration set is 2 hours. When using a Type II compass calibration pad without the magnetic compass calibration set, approximately 1 hour is required.

11620-3 SITING. Existing paved areas located where earth's magnetic field is uniform are suitable for use as compass calibration pads. New Type II pads with compass rose and turntable are planned only where required for aircraft not adaptable to the magnetic compass calibration set.

11620-4 MINIMUM DISTANCES. Minimum distances from potential magnetic interference structures to the center of the pad are: 84 meters (275 feet) to the centerline of the nearest taxiway or towway; 69 meters (225 feet) to underground metal conduits and piping; 84 meters (275 feet) to the edge of aircraft and vehicle parking areas; 152 meters (500 feet) to underground powerline; 183 meters (600 feet) to overhead steam lines, a.c. power lines and/or equipment, nearest edge of railroad

tracks, nearest portion of building containing any magnetic material; 305 meters (1,000 feet) to d.c. power lines and/or equipment.

11620-5 ACCESS TAXIWAY TO CALIBRATION PAD. The access taxiway to the calibration pad is oriented to facilitate moving the aircraft onto the pad, headed toward magnetic north. Each pad requires a target placed at a known but arbitrary bearing at a distance of approximately 805 meters (one-half mile) from the pad and visible from both the aircraft and the compass calibration set.

11620-6 GROSS AREA REQUIRED FOR CALIBRATION PAD. The gross area required for a compass calibration pad exclusive of access taxiway is 1,340 M² (36.6 m by 36.6 m) (1,600 square yards (120 ft by 120 ft)).

116 35 ARMING AND DE-ARMING PAD (M²/SY)

FAC: 1131

BFR Required: Y

Design Criteria: UFC 3-260-01, Airfield and Heliport Planning and Design; Military Handbook 1021/1, Airfield Geometric Design

Planning Criteria: UFC 3-260-01, Airfield and Heliport Planning and Design; NAVSEA OP-5 – Volume I, latest revision, Ammunition Ashore Regulations for Handling, Storing, Production, Renovation and Shipping

11635-1 DESCRIPTION. This pad provides a paved area for activating or deactivating weapons systems on-board aircraft. It is utilized at all Navy and Marine Corps air installations where gunnery, rocketry, and/or missile firing are conducted. The average time for arming an aircraft is 20 minutes, and for de-arming an aircraft, 30 minutes. All aircraft on the pad may be either armed or de-armed simultaneously; however, arming and de-arming cannot occur simultaneously on the same pad. The number of pads at an installation depends upon the demand at that installation. The pads are sited at either end of the primary runway and, if additional pads are required, at either end of the crosswind runways.

11635-1.1 Type A. The gross area of the Type A pad (exclusive of the access taxiway) is 2,138 square meters (30.5 meters by 70.1 meters) (2,556 square yards (100 feet by 230 feet). The Type A pad will accommodate simultaneously four helicopters (AH-1 type).

11635-1.2 Type B. The gross area of the Type B pad (exclusive of the access taxiway) is 5,434 square meters (45.7 meters by 118.9 meters) (6,500 square yards (150 feet by 390 feet). The Type B pad will accommodate simultaneously four fixed wing attack (VA) aircraft or four fixed wing fighter (VF) aircraft.

11635-1.3 Type C. The gross area of the Type C pad (exclusive of the access taxiway) is 6,526 square meters (79.3 meters by 82.3 meters) (7,800 square yards (260 feet by 270 feet). The Type C pad will accommodate simultaneously two fixed wing patrol (VP) aircraft.

11635-2 PARKING AT PAD. Aircraft utilizing the pad normally park parallel to the runway but in any case they park headed in the direction providing the maximum length of undeveloped space along the extended longitudinal centerline of the aircraft. In no case is arming or de-arming of propelled armament conducted when the aircraft is headed towards inhabited areas on or near the air installation.

116 40 PRECISION APPROACH RADAR (PAR) PAD (M2/SY)

FAC: 1164

BFR Required: N

Design Criteria: Military Handbook 1024/1, Aviation Operational and Support Facilities; Technical Manuals for Specified Equipment

11640-1 PAR PAD. The Precision Approach Radar (PAR) pad is a paved hardstand provided to support the PAR equipment in operating position. The hardstand must be a minimum of 146 square meters (12.1 meters by 12.1 meters) (178 SY (40 feet by 40 feet)). Technical manuals provided by the equipment manufacturers should also be consulted in order to determine the most appropriately sized pad. The number of pads required depends on the number of PAR units at the air installation. At installations where PAR approaches are provided to more than one runway by a single PAR unit, a turntable is provided to allow PAR service to more than one runway. Technical manuals for the respective equipment describe acceptable locations for the pad.

116 41 PRECISION APPROACH RADAR (PAR) PAD (M2/SY)

FAC: 1164

BFR Required: N

11640-1 DESCRIPTION. A paved hardstand pad that provides support to the Improved Fresnel Lens Optical Landing System (IFLOLS) equipment in operating position.

116 42 BLAST PROTECTIVE PAVEMENT (M2/SY)

FAC: 1164

BFR Required: N

Design Criteria: Military Handbook 1021/1, Airfield Geometric Design

11642-1 DESCRIPTION. Blast protective pavement is provided adjacent to the runway threshold and end turnoff for all runways except those at basic training propeller aircraft fields. However, in cases where the training propeller aircraft is not an exclusive use to the airfield, blast protective pavement is a requirement. Permanently based aircraft and significant transient aircraft and services should be included in determining a requirement for pavement protection. Blast protective pavement may be required in other locations for aircraft, such as the F/A-18 with downward exhausted auxiliary power units, the AV-8B with ducted exhaust, and the V-22 with both down turbine exhaust and propeller wash. The area of blast protective pavement required for a particular aircraft

may be determined from exhaust plume data in Naval Air Training and Operating Procedures Standardization (NATOPS) or engine manufacturers specifications for developmental aircraft. For aircraft including F/A-18, AV-8B, and V-22 the width of the blast protective pavement is 30.5 meters (100 feet) except for Master Jet Air Stations where the width shall be 37.5 meters (125 feet).

116 45 LINE VEHICLE PARKING (M2/SY)

FAC: 1164

BFR Required: N

Design Criteria: Military Handbook 1021/1, Airfield Geometric Design; NAVAIR 00-80T-109

11645-1 VEHICLE PARKING SPACES. Line vehicle parking spaces contiguous to taxiway and parking aprons are allocated for ground support equipment assigned for flight line use. See Table 11645-1 for space requirements.

Table 11645.1. Line Vehicle Parking

Equipment	Area (M2)	Area (SY)
Tow Tractor	16.7	20
Refueling Truck (1)	39.3	47
Refueling Trailer (1)	58.5	70
Mobile Electric Power Plant	10	12
Nitrogen/Oxygen Trailer	6.7	8
Air Conditioning Trailer	10	12
Utility Vehicle	16.7	20
Bomb Truck	16.7	20
Bomb Trailer	12	14
Industrial Flatbed Truck	7.5	9
Industrial Platform Truck	7.5	9

Note: (1) Parking for both truck and trailer refuelers should be sited away from the flightline to reduce and/or eliminate hazards. NAVAIR 00-80T-109 states that refuelers and fuel servicing equipment will be parked in designated areas which have a minimum lateral separation of 7.6 meters (25 feet), measured center to center of truck, between trucks. It also states that no refuelers and fuel servicing equipment will be parked closer than 30.5 meters (100 feet) to any inhabited building.

11645-2 PARKING FOR FIRE AND RESCUE VEHICLES. Parking for aircraft fire and rescue vehicles are provided separately. See Category Code 141 20, Aircraft Fire and Rescue Station and Category Code 116 60, Fire and Rescue Vehicle Alert Pad.

11645-3 OPTIMUM EFFICIENCY. Parking areas shall be selected to permit optimum efficiency in the use of equipment (for example, squadron vehicles will normally be assigned space close to the squadron maintenance hangar) and to conform to lateral safety clearances for existing and projected airfield pavements. Where weather requires and the clearances permit, shelter for line vehicles may be provided.

116 50 TOWWAY (M2/SY)

FAC: 1131

BFR Required: N

Design Criteria: UFC 3-260-01, Airfield and Heliport Planning and Design; Military Handbook 1021/1, Airfield Geometric Design

Planning Criteria: UFC 3-260-01, Airfield and Heliport Planning and Design

11650-1 DESCRIPTION. A tow way is a paved roadway used for towing fixed or rotary wing aircraft from one area to another. It differs from a taxiway in that aircraft do not move on it under their own power. Tow ways may be authorized at air installations where it is necessary to tow aircraft from one operational area to another and in some instances, particularly at air installations with jet aircraft, to minimize noise conditions. Tow way pavement is normally provided at industrial seaport air installations where carrier berthing facilities include those for unloading and loading of aircraft. Pavement marking, particularly centerline, should be provided, and lighting provided if operations are to be conducted at night.

11650-2 TOWWAYS ON EXISTING STREETS AND ROADS. In some cases, towways will be on existing streets and roads or abandoned runways and taxiways, which may be tailored for this use. Such modification will include reconstruction or strengthening of existing facilities to support the maximum aircraft loading that will be superimposed at each location, as well as provision for adequate horizontal and vertical clearances. Jet blast criteria and shoulder specification need not be considered.

11650-3 TYPICAL TOWWAY WIDTHS. Tow ways are planned for air installations based upon the installation mission and type aircraft to be moved. Typical tow way widths are 10.7 meters (35 feet) to support Navy and Marine Corps rotary wing aircraft, 11.0 meters (36 feet) to support Navy and Marine Corps fixed wing carrier-based aircraft, and 12.2 meters (40 feet) to support Navy and Marine Corps Patrol and Transport aircraft.

116 55 ORDNANCE HANDLING PAD (M2/SY)

FAC: 1131

BFR Required: Y

Design Criteria: UFC 3-260-01, Airfield and Heliport Planning and Design; Military Handbook 1021/1, Airfield Geometric Design

Planning Criteria: NAVFAC P-80.3, Facility Planning Factor Criteria for Navy and Marine Corps Shore Installations; Appendix E, Airfield Safety Clearances, UFC 3-260-01, Airfield and Heliport Planning and Design; ; NAVSEA OP-5 – Volume I, latest revision, Ammunition Ashore Regulations for Handling, Storing, Production, Renovation and Shipping

11655-1 DESCRIPTION. An ordnance handling pad is provided for air installations where there is a requirement for loading or off-loading explosives from cargo aircraft and where no apron is available for use without violating explosive safety distance criteria. The pads are designed for use by cargo aircraft and will generally vary in size depending on the type of ordnance being handled and the number and type of aircraft to be loaded/unloaded simultaneously.

11655-1.1 Types of Pads:

- a. Circular: At aviation facilities used by small cargo aircraft, the Ordnance Handling Pad is a circular pad as shown in Figure 11655-1
- b. Semi-Circular: At aviation facilities used by large cargo aircraft and Aerial Ports of Embarkation (APOE) and Aerial Ports of Debarcation (APOD), the Ordnance Handling Pad is a semi-circular pad as shown in Figure 11655-2. The semi-circular pad is adequate for aircraft up to and including the dimensions of a C-5 aircraft.

11655-1.2 Dimensions. The Ordnance Handling Pad geometric dimensions shown in Figures 11655-1 and 11655-2 are minimum requirements. Ordnance Handling Pads may be larger than these if the design aircraft cannot maneuver on the pad.

Figure 11655-1. Ordnance Handling Pad Other Than APOE/Ds

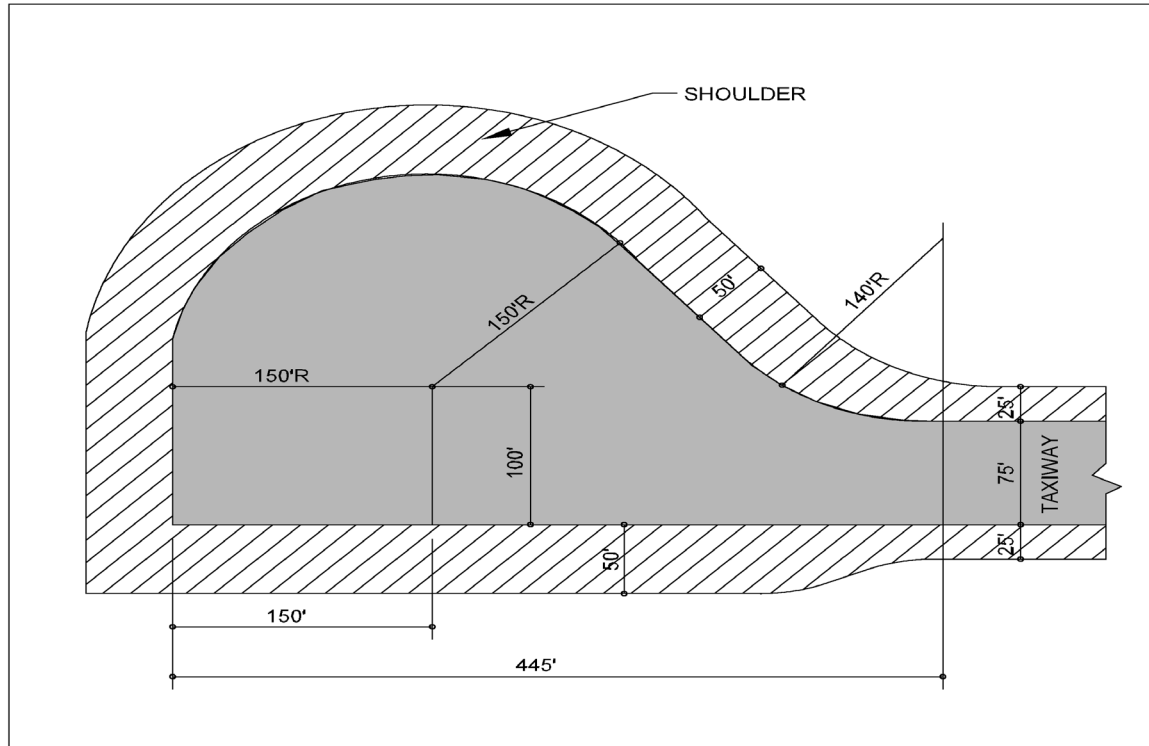
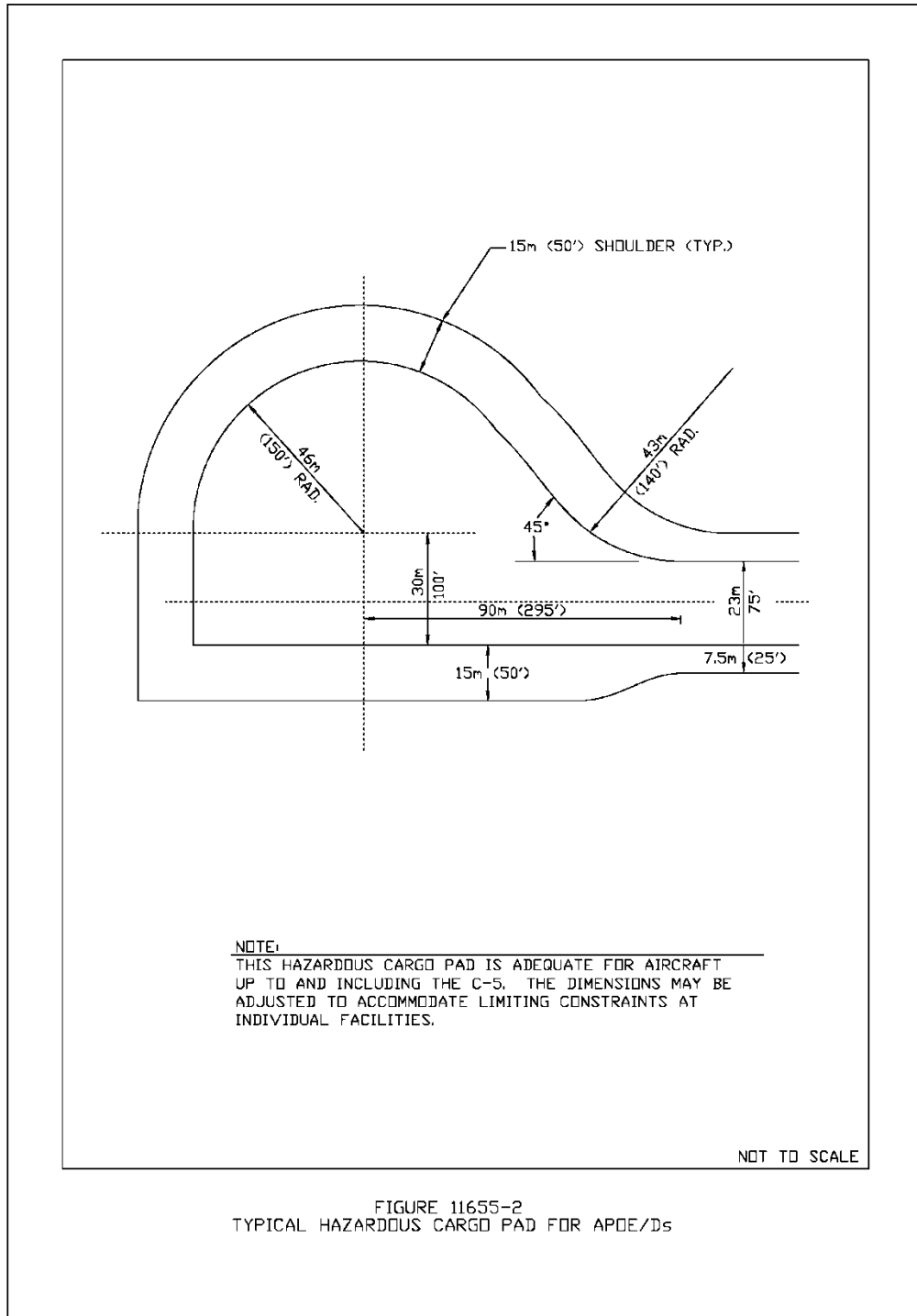

Figure 11655-2. Ordnance Handling Pad for APOE/Ds



11655-2 ORDANCE HANDLING PAD SITING. The ordnance handling pad shall be sited in accordance with standards published in NAVSEA OP-5 - Volume I, latest revision (Ammunition Ashore Regulations for Handling, Storing, Production, Renovation and Shipping). Also, the ordnance pad should be sited in accordance with all pertinent airfield safety criteria. Barricades shall be provided where required by explosives safety criteria or where installation will produce a net reduction in construction and land acquisition costs.

11655-3 JOINT USE CONSIDERATION. Consideration should be given to a joint use Combat Aircraft Loading Area (CALA), Category Code 116-56, for ordnance handling provided the CALA is sited in accordance with the guidelines stated above.

116 56 COMBAT AIRCRAFT LOADING AREA (CALA) (M2/SY)

FAC: 1131

BFR Required: Y

Design Criteria: UFC 3-260-01, Airfield and Heliport Planning and Design

Planning Criteria: NAVFAC P-80.3, Facility Planning Factor Criteria for navy and Marine Corps Shore Installations; Appendix E, Airfield Safety Clearances, UFC 3-260-01, Airfield and Heliport Planning and Design; ; NAVSEA OP-5 – Volume I, latest revision, Ammunition Ashore Regulations for Handling, Storing, Production, Renovation and Shipping

11656-1 DESCRIPTION. The combat aircraft ordnance loading area is primarily an apron where explosives are loaded/off-loaded from combat aircraft departing and/or returning from weapons training flights. This area is required where there is not space available on the parking apron for loading mass detonating ordnance which will meet the explosive safety requirements specified in NAVSEA OP-5, Volume I, latest revision (Ammunition and Explosives Safety Ashore Regulations for Handling, Storing, Production, Renovation and Shipping). The weapons are not armed on this apron, see Category Code 116-35, Arming and De-arming Pad.

11656-2 COMPLIANCE WITH EXPOSIVE SAFETY CRITERIA. Due to the ordnance handling taking place on this apron, its location with respect to other facilities shall be determined using explosives safety criteria specified in NAVSEA OP-5, Volume I, latest revision. In addition, the airfield safety criteria specified in NAVFAC P-80.3,

11656-3 Airfield Safety Clearances apply and:

- a. The apron must be outside of the runway primary surface
- b. Parked aircraft shall not penetrate any transitional surface
- c. No objects shall be sited within 30.5 meters (100 feet) of the edge of this apron

11656-4 CRITERIA. There is no standard size for a combat aircraft ordnance loading area. The area required is a function of the number of aircraft to be simultaneously loaded/unloaded and the class and net explosive weight of the ordnance to be carried by each aircraft. Aircraft on the apron shall be separated from each other by the above ground magazine (unbarricaded, K=11) distances specified in OP-5, Volume I, latest revision. The greater the net explosive weight on the aircraft, the

greater the required separation. However, as a minimum, the aircraft spaces shall be separated by not less than the A, B, C, and D dimensions specified for parking aprons, Category Code 113 20. Peripheral taxi lanes shall be provided as required to provide safe access to parking spaces. For aircraft with less than 21.3 meter (70 foot) wingspan, a 22.9 meter (75 foot) wide peripheral taxi lane will provide sufficient wingtip clearance for a single aircraft to taxi past parked aircraft (assumes a 3.05 meter (10 foot) clearance between outermost tire of the taxiing aircraft and the edge of pavement). For aircraft with a wingspan of 21.3 meters (70 feet) or greater, the peripheral taxi lane width shall be determined using the clearance criteria shown in Figure 11320-5, Category Code 113 20. The minimum peripheral taxi lane width shall be 22.9 meters (75 feet).

11656-5 SIZING FOR LOADING SCENERIOS. The apron most likely will have to be sized to accommodate several loading situations. For example, parking locations could be spaced such that twelve aircraft could each be loaded with 227 kgs (500 lbs) net explosive weight or six aircraft, parked in alternate spaces, could each be loaded with 2,270 kgs (5,000 lbs) net explosive weight. The maximum net explosive weight to be on the apron at one time shall be used in determining the explosive quantity distance arcs for the apron. These arcs shall be measured from the edge of the apron pavement, including the peripheral taxi lanes. Justification shall be provided for the number of aircraft and the net explosive weight per aircraft chosen for sizing the apron. Strong consideration shall be given to providing a joint use apron for ordnance handling from cargo aircraft, Category Code 116-55, and the combat aircraft ordnance area if these operations can be scheduled on a non-concurrent basis. If supporting facilities such as an ordnance operations building, or fixed point utility system are required, they shall be individually justified.

116 60 FIRE AND RESCUE VEHICLE ALERT PAD (M2/SY)

FAC: 1164

BFR Required: N

Design Criteria: NAVAIR 00-80R-14, Aircraft Firefighting and Rescue NATOPS Manual

Planning Criteria: NAVFAC P-80.3, Facility Planning Factor Criteria for Navy and Marine Corps Shore Installations; Appendix E, Airfield Safety Clearances

11660-1 DESCRIPTION. This facility provides parking area for Immediate Response Alert Vehicle. The purpose of the Immediate Response Alert is to:

1. Observe all landings and take-offs.
2. Respond immediately to any aircraft accident.
3. Provide timely rescue of personnel involved in emergencies.

11660-2 SIZE AND LOCATION. The pad should be large enough to park one 3,780 liter (1,000 gallon) aircraft rescue and fire fighting vehicle (P-19) and should be located no closer than 45.7 meters (150 feet) from the runway edge. The pad should not include a protective shelter or any other structure, which would violate airfield safety clearance criteria. See NAVFAC P-80.3 for guidance. The pad should be connected to the runway by a 4.9 meter (16 foot) wide access road to the runway. If there is no

access from the crash house to the alert pad other than from the runway, the parking space should be widened as required to allow the truck sufficient space to turn around (see Table 11660-1).

Table 11660-1. 3,780 Liter (1,000 Gallon) Aircraft Rescue and Fire Fighting Vehicle Dimensions (P-19)

Weight = 15,200 kg (3,600 lbs)
Width = 2.4 meters (8 feet)
Length = 8.3 meters (27.1 feet) (over bumpers)
Inside turning radius ("wall to wall") = 24.4 meters (80 feet)

11660-3 MULTIPLE ALERT PADS. Normally there will be one alert pad per air station. However, multiple alert pads will be required when more than one runway is in use and operations cannot be observed from a single vantage point. The optimum location is on either side of the runway and near the middle of the airfield, but may vary depending upon the best observation of the runway. Consideration should be given to maximum utilization of existing abandoned pavements prior to construction of an alert pad.

11660-4 ELECTRICAL POWER JUSTIFICATION. Normally electrical power is not provided to the Alert Pad. However, when power is required to charge the truck batteries, requirements must be individually justified. For additional information see NAVAIR 00-80R-14 Aircraft Firefighting and Rescue NATOPS Manual.

116 65 TACTICAL SUPPORT VAN PAD (M2/SY)

FAC: 1164

BFR Required: Y

Planning Criteria: NAVAIRINST 13670.1B

11665-1 DESCRIPTION. This facility consists of a concrete pad and support structure to accommodate groups of relocatable tactical shelters or "vans". Numerous functions at Navy and Marine Corps installations are done in relocatable shelters. These shelters, while referred to by different nomenclatures depending on usage, are commonly called "vans". They are generally aluminum structures built to commercial standards of 2.4 meters (8 feet) in width and height, and 6.1 meters (20 feet) in length. These vans can be carried by any military or commercial cargo carrier by air, ship, truck, or rail. Vans are designed to be grouped together with removable doors, access panels, and butting kits and can be configured for solo use or grouped in large complexes.

11665-2 TYPES OF VANS:

11665-2.1 Interconnect Unit (INU). Placed in the center of groups and used to connect vans of the other types together. INUs have a door at each end and three access panels on the sides for the joining of up to five vans to each INU.

11665-2.2 Basic. Internally configured for a specific mission from administrative to maintenance. These vans can be joined only with another van at each end.

11665-2.3 Other (Right, Left, Middle). These type of vans are used in specific configurations to make up double and triple wide vans. These vans can only be joined to a complex at the end of another basic van.

11665-3 MAXIMUM VAN GROUP SIZE. By NAVAIR Instruction, van groups cannot be larger than six INUs connected end to end with a maximum of two vans extending from each side. In this configuration, up to 42 vans can be joined together.

11665-4 EXAMPLES OF VAN COMPLEXES: By combining groups of 42 vans into larger complexes with other temporary structures, an entire Marine Aviation Logistics Squadron (MALS) can set up and operate from an unimproved forward deployed site. By far the largest user of vans is the MALS. Referred to as Mobile Maintenance Facilities (MMF), these vans are deployed in large complexes with the Marine Air group (MAG) to support various missions. Navy activities also use MMFs, primarily for P-3 deployable sites where Intermediate level support does not exist. Other units that utilize vans for tactical shelters when deployed are Mobile Calibration Laboratories (MCC), Marine Wing Support Squadrons (MWSS), Marine Wing Control Squadrons (MWCS), Marine Air Support Squadrons (MASS), and Marine Air Control Squadrons (MACS). When not forward deployed, these vans are used in various roles. Most MALS units utilize a large part of their vans to provide intermediate level maintenance support to home based squadrons, just as they would if they were deployed. Most other units use their vans for training.

11665-5 REQUIREMENT: All vans require a concrete pad and utility support when at home base. This allows the vans to be used, maintained, and always ready to deploy for their primary mission. This structure consists of two parts, the pad and a nearby support building.

11665-6 PAD SIZE REQUIREMENTS. Pads are built to accommodate the unit and van configuration of a specific mission. They are sized to hold the required quantity of vans established by the holding unit to accomplish the specific mission. The following guidance shall be used to size pads:

- a. For groups of up to 42 vans, establish the quantity and layout with the unit. Provide a pad sized to fit the required layout with a 0.152 meter (2 foot border)
- b. For groups of 42 vans, provide a 1,120 M2 (1,333 SY) pad.

- c. For groups of more than 42 vans, divide the quantity by 42 and multiply number of areas by 1,120 M2 (1,333 SY) and add a 4.6 meter (15 foot) access lane between areas. Add 93 M2 (111 SY) for storage of bogie wheels and other towing gear for van movement.

11665-7 PAD UTILITY REQUIREMENTS. Pads require electrical power, phone and computer line connections, compressed air, and water for washing vans. It will also require an environmental drainage system for wash water runoff.

11665-8 SUPPORT BUILDING. The support building is required if the van pad is built away from other facilities or the existing nearby facilities cannot handle the personnel load that would be placed upon them by the extra personnel working in the vans. The pad size guidance provided above DOES NOT include the space required for the support building.

11665-9 SUPPORT BUILDING SPACE REQUIREMENTS. The support building is required to house personnel space such as restrooms and locker rooms, storage for van parts such as door and access panels that have been removed for complexing of vans, mechanical equipment rooms for power, phone and computer distribution, and air compressors. The following guidance shall be used to size support building:

- a. Provide 4.6 M2 (50 SF) of covered storage for every two INUs or every four of the other types of vans.
- b. Provide 1.8 M2 (19 SF) per person for restrooms, lockers, showers and dressing rooms.

Either use the actual manning of the van complex
OR assume 1.2 persons per van.

- c. Provide 13.9 M2 (150 SF) for mechanical equipment area to support the vans.

11665-10 NET TO GROSS FACTOR. The support building figures listed above are net M2 (net SF). All figures should be multiplied by 1.25 (net to gross factor) to provide areas for aisles, fire protection, HVAC, and structure.

Tactical Support Van Pad Sizing - Computation Example 1

An MWCS unit has eight vans consisting of two INUs and six basic vans laid out as shown in Figure 11665-1 "Typical Small Complex Van Pad Layout".

These vans are occupied by 12 personnel.

Pad Size Calculation:

The layout of the vans is 12.3 meters (40.5 feet) by 14.9 meters (49 feet).

Adding a 0.6 meter (2 foot) border makes the pad 13.6 meters (44.5 feet) by 16.2 meters (53 feet) or 219 M2 (262 SY).

As this is a single group, the 4.6 meter (15 foot) access lane IS NOT required.

Pad Total = 219 M2 (262 SY)

Support Building Size Calculation:

Number of INUs = 2

Number of others = 6

Number of personnel = 12

Covered Storage:

INUs: $2 / 2 = 1.0$

Others: $6 / 4 = 1.5$

$1.0 \times 4.6 \text{ M2 (50 SF)} + 1.5 \times 4.6 \text{ M2 (50 SF)} = 11.5 \text{ M2 (125 SF)}$

Restrooms, Locker Rooms, Showers and Dressing Rooms:

$12 \times 1.8 \text{ M2 (19 SF)} = 21.6 \text{ M2 (228 SF)}$

Mechanical Room:

13.9 M2 (150 SF)

Support Building Subtotal (Net)

$11.5 \text{ M2} + 21.6 \text{ M2} + 13.9 \text{ M2} = 47.0 \text{ M2 (net)}$

$(125 \text{ SF} + 228 \text{ SF} + 150 \text{ SF} = 503 \text{ SF (net)})$

Support Building Total (Gross)

$47.0 \text{ M2 (net)} \times 1.25 = 58.8 \text{ M2 (gross)}$

$(503 \text{ SF (net)} \times 1.25 = 629 \text{ SF (gross)})$

Figure 11665-1. Typical Small Complex Van Pad Layout

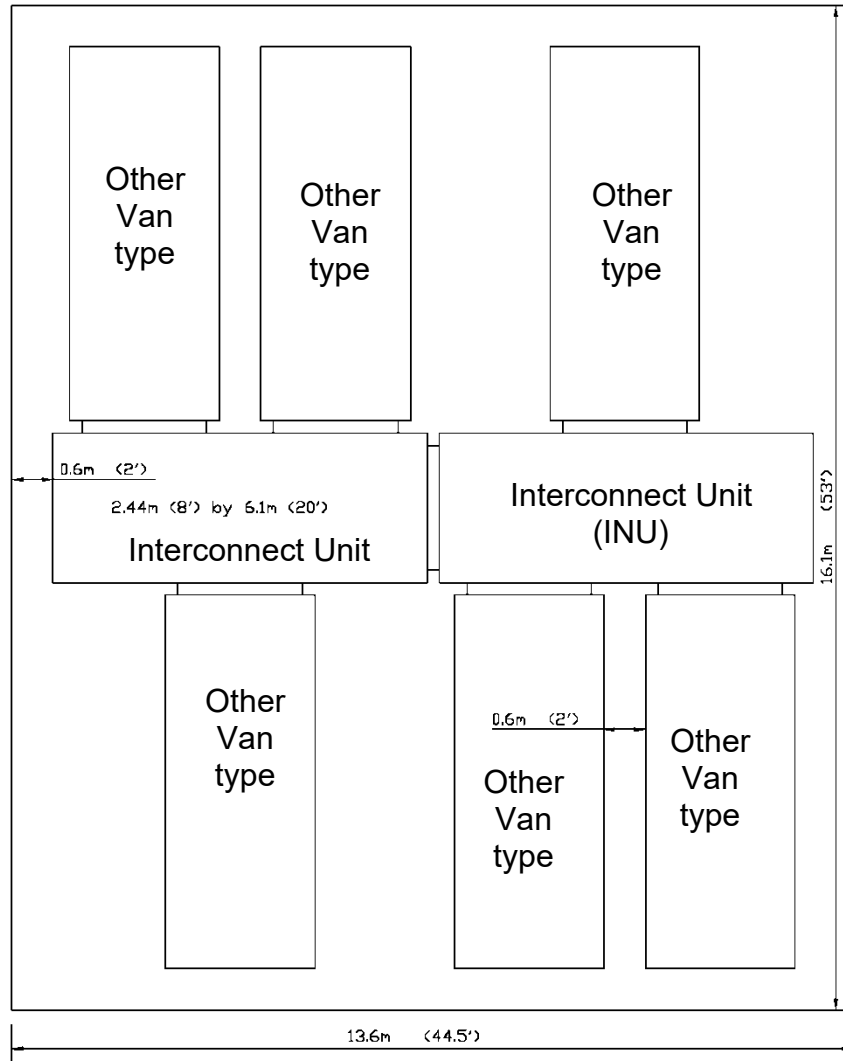

NOT TO SCALE

Tactical Support Van Pad Sizing - Computation Example 2

A MALS unit has 250 vans laid out as shown in Figure 11665-2. "Typical Large Complex Van Pad Layout".

The personnel loading is unknown.

Pad Size Calculation:

For van complexes consisting of more than 42 vans,
 $250 / 42 = 5.95$, say 6 groups

Place a 4.6 meter (15 foot) access lane between each of the 6 groups
 gives a pad size of 81.7 meters (268 feet) by 95.1 meters (312 feet) or
 7,770 M2 (9,291 SY)

add 93 M2 (111 SY) for storage

Pad Total = $7,770 \text{ M2} + 93 \text{ M2} = 7,863 \text{ M2}$
 $(9,291 \text{ SY} + 111 \text{ SY} = 9,402 \text{ SY})$

Support Building Size Calculation:

Number of INUs = $6 \times 6 = 36$

Number of others = 250

Number of personnel = unknown (assume $1.2 \text{ pn/van} \times 250 \text{ van} = 300 \text{ pn}$)

Covered Storage:

INUs: $36 / 2 = 18$

Other: $(250 - 36) / 4 = 53.5$

$18 \times 4.6 \text{ M2 (50 SF)} + 53.5 \times 4.6 \text{ M2 (50 SF)} = 328.9 \text{ M2 (3,575 SF)}$

Restrooms, Locker Rooms, Showers and Dressing Rooms:

$1.8 \text{ M2 (19 SF)} \times 300 = 540 \text{ M2 (5,700 SF)}$

Mechanical Room:

13.9 M2 (150 SF)

Support Building Subtotal (Net)

$328.9 \text{ M2} + 540.0 \text{ M2} + 13.9 \text{ M2} = 882.8 \text{ M2(net)}$

$(3,575 \text{ SF} + 5,700 \text{ SF} + 150 \text{ SF} = 9,425 \text{ SF(net)})$

Support Building Total (Gross)

$882.8 \text{ M2(net)} \times 1.25 = 1,103.5 \text{ M2(gross)}$

$(9,425 \text{ SF(net)} \times 1.25 = 11,781 \text{ SF(gross)})$

Figure 11665-2. Typical Large Complex Van Pad Layout

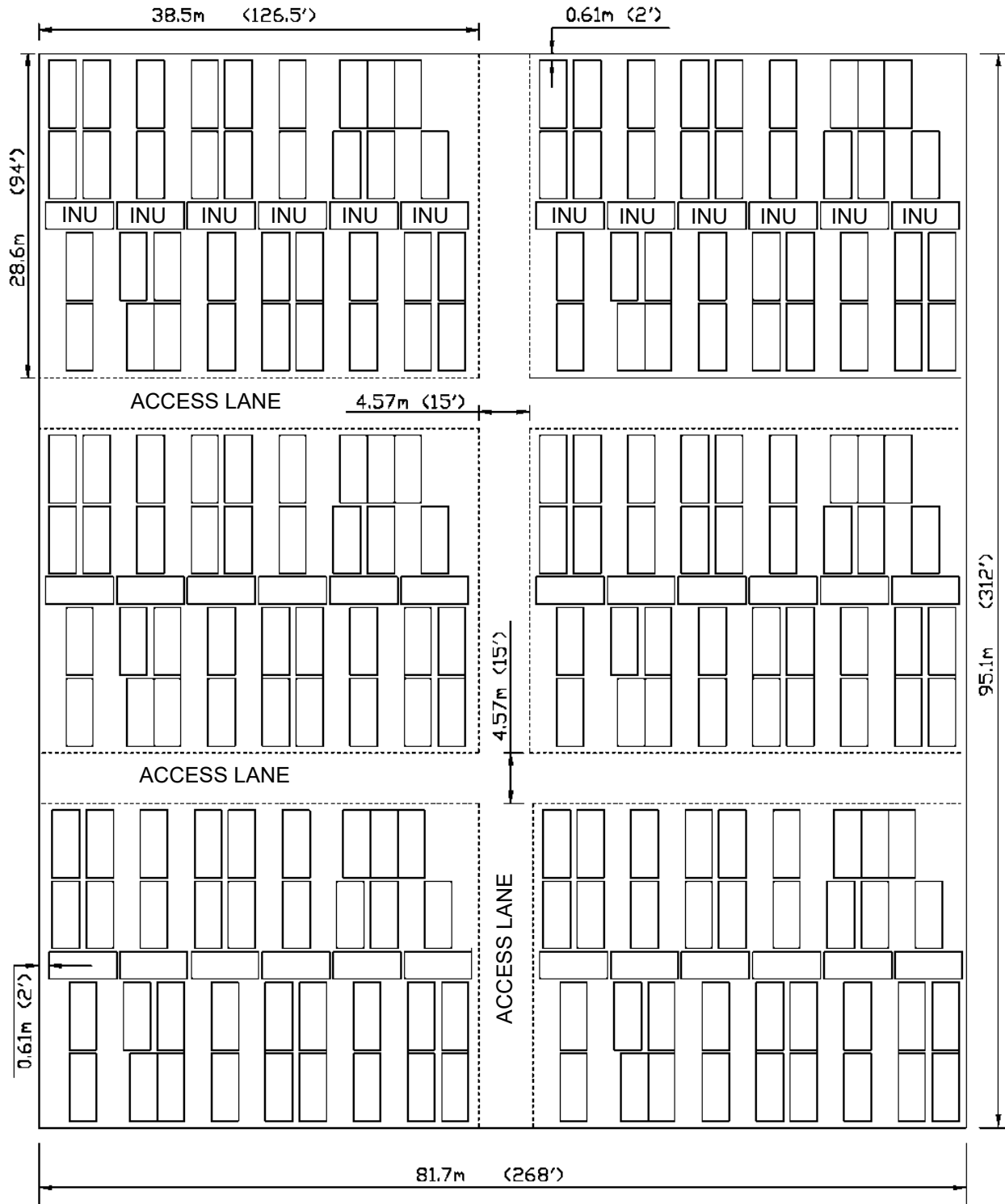

NOT TO SCALE

121 AVIATION FUEL FACILITIES

121 10 AIRCRAFT DIRECT FUELING STATION (GM)

FAC: 1211

BFR Required: Y

12110-1 **DESCRIPTION.** Aircraft direct fueling stations provided outlets where aircraft can be fueled from a closed circuit fuel system as opposed to refueler trucks.

12110-2 **POLICY.** Refueler trucks are the preferred method to fuel aircraft. However, direct fueling stations may be considered for: (1) carrier aircraft, including helicopters, when the mission dictates a continuing need for rapid turnaround without shutting engines down, (2) cargo/transport aircraft with prescribed short ground times or (3) patrol aircraft which require an average refueling of 2500 gallons or more. Aircraft direct fueling stations shall be installed only when authorized by NAVFACENGCOCOM HQ and NAVAIRSYSCOM HQ. NAVFACENGCOCOM HQ (Code 04) and NAVAIRSYSCOM HQ (Code 4106) will provide technical assistance for the determination of the type and number of fueling station.

12110-3 **CRITERIA.** Aircraft direct systems utilize multi-arm pantographs with closed circuit type nozzle assemblies. Cargo/transport aircraft may also be refueled from flush type direct fueling stations located in the apron in conjunction with hose/pantograph trailers or trucks. However, flush fueling stations should only be used where taxi patterns preclude the parking of aircraft in spaces which can be reached by apron edge fueling stations with fully extended (135 foot maximum reach) five arm pantographs.

The number of fueling outlets required must be determined by an engineering analysis. Where aircraft require quick turnaround, (i.e. transport aircraft with minimum ground time, tactical aircraft returning to the air without shutting down engines, or patrol aircraft on ready alert status), the number of fueling outlets required is a function of the number of aircraft that must be refueled within the specific time frame. Unified Facilities Criteria (UFC) 3-460-01 "Design: Petroleum Fuel Facilities" provides guidance on the minimum number of outlets, fuel flow per outlet and total fuel flow required in the system. Systems are designed such that the flow in the system is less than the sum of the maximum outlet capacities. Three or four outlets each capable of delivering 600 gallons per minute (GPM) can be adequately served by a system with a capacity of 1200 GPM.

When determining the number of outlets required for simultaneous refueling of aircraft, the average rate at which the aircraft can receive fuel shall be used rather than the maximum GPM capacity of the outlet. For example, if the average fuel receiving rate for an aircraft is 250 GPM (the actual rate varies during filling), and the aircraft normally requires 2000 gallons of fuel, the fill-up time equals 2000/250 or 8 minutes. Allowing 7 minutes for other functions such as brake check, taxiing, hook-up, paperwork, etc., one aircraft can refuel every 15 minutes. In this case, each outlet could fuel 4 aircraft per hour. If the mission requirement is to turnaround 8 aircraft per hour, two outlets will be

required. UFC 3-460-01 "Design: Petroleum Fuel Facilities" specifies a minimum of 2 outlets per fueling system.

12110-4 **SITING REQUIREMENTS.** The location of fueling stations at an activity depends on the aircraft mission and configuration of runways, taxiways, and aprons. The fueling stations may be located adjacent to through taxiways, parking aprons or dedicated fueling taxiways. See NAVFAC P-272, Drawing 1403986, for the layout of a fueling station with dedicated taxiways. Where direct fueling is used to hot fuel tactical aircraft, fueling stations shall be located to allow quick return to the runway. For cargo/transport aircraft, the fueling stations shall normally be located adjacent to where the aircraft are loaded/unloaded so that fueling may be done simultaneously with other logistic operations. Patrol aircraft may be fueled at their parking spaces or at some point en route to the runway.

Direct fueling stations shall be sited outside of the runway or helipad primary surface and such that fueling equipment and the aircraft to be refueled do not penetrate the transitional surface as defined in NAVFAC P-80.3. Direct fueling stations shall not be sited beneath the approach-departure clearance surface. Fueling stations with dedicated access taxiways shall be located a minimum of 100 feet from the edge of a parking apron and 150 feet from the centerline of a through taxiway. The size and spacing of fueling lanes shall be in accordance with NAVFAC P-272, Definitive Drawing 1403986. Normally, when fueling stations are proposed adjacent to parking aprons or through taxiways, an airfield safety waiver from NAVAIRSYSCOM would be required prior to construction. However, in this case no formal waiver is required provided NAVFACENCOM and NAVAIRSYSCOM have approved overall-planning for the project. Aircraft direct fueling stations shall not be sited within 200 feet of an inhabited building. Siting of fuel dispensing facilities must consider the effects of electromagnetic radiation; see UFC 3-460-01 "Design: Petroleum Fuel Facilities" for guidelines.

121 20 AIRCRAFT TRUCK FUELING FACILITY (GM)

FAC: 1261

BFR Required: Y

12120-1 **DESCRIPTION.** An aircraft truck fueling facility is used to transfer fuel to aircraft refueling trucks. The fueling equipment is located on concrete islands which are designed to provide fuel from one side only. Where more than one island (one fueling outlet per island) is required, they shall be arranged parallel to each other with 15 feet between adjacent sides. The pavement between islands is sloped to a drain or catch basin which is connected to a containment area in case of a fuel spill. See NAVFAC P-272, Definitive Drawing 1403987 for a sketch of a typical refueler truck fill stand and UFC 3-460-01 "Design: Petroleum Fuel Facilities" for design criteria.

12120-2 **POLICY.** The use of refueler trucks is the preferred method to fuel aircraft. However, see Category Code 121 10 to determine when a direct fueling system may be considered. When direct fueling is provided, it is always in conjunction with truck fueling. An aircraft truck fueling facility supplied from a spur of the direct fueling system usually reduces non-productive truck time and is less costly than a separate truck

fueling facility because the filter/separator and fuel monitor would be omitted. Also, depending upon the spurs' location in the system, a relaxation chamber may not be required. See NAVFAC definitive drawing 1403985 and UFC 3-460-01 –“ Design: Petroleum Fuel Facilities”. The determination of number of grades of fuel to be handled and the number of outlets required for each grade shall be made in conjunction with NAVFACENGCOCOM HQ (Code 04) and NAVAIRSYSCOCOM HQ (Code 4106).

12120-3 **CRITERIA.** The number of outlets required must be determined by an engineering analysis. The maximum capacity of each outlet is 600 gallons per minute (GPM). Factors to be considered in the engineering analysis include:

- **The number of grades of fuel to be provided.** Each grade requires a separate outlet.
- **The number of aircraft that must be refueled during peak periods of recovery and launch.**
- **The rate at which the fueling facility can fill refueler trucks.** Refueler trucks can accept up to 600 GPM, however, a figure of 450 GPM is more typical of rates achieved. Standard Navy refueler trucks can hold 5000 gallons of fuel. The capacity of refueler trucks in contract refueling operations vary and 8000 gallons is not uncommon.
- **The rate refueler trucks can fuel aircraft.** While refueler trucks can dispense fuel at approximately 250 GPM, only the larger and more modern jet aircraft can accept fuel at that rate and then only during the initial refueling phase. For planning purposes, the average aircraft fueling rates should be 200 GPM for large jet aircraft (Patrol/transport), 150 GPM for tactical jet aircraft and 100 GPM or less for rotary wing jets and all reciprocating engine aircraft using aviation gasoline (AVGAS). Some larger aircraft can simultaneously take on fuel from two trucks in which case a combined average flow of 400 GPM can be used.
- **The distance the refueler trucks have to transit between the fueling stand and the aircraft.** The distance should be minimized to reduce transit times.

The analysis should consider that aircraft can be refueled overnight for morning departures. Peak demand for the truck fueling facility will normally occur at mid-morning or mid-afternoon when high rates of aircraft recovery are experienced.

12120-4 **SITING.** Aircraft Truck fueling facilities shall not be sited within the primary surface or under the approach/departure clearance surface of any runway or helipad. The facilities shall be sited so that no part of the fueling stand, equipment or refueler truck penetrates the imaginary surfaces specified in NAVFAC P-80.3 or the airfield safety clearances published in UFC 3-460-01 - Design: Petroleum Fuel Facilities (see criteria for runways, helipads, taxiways, and aprons). The fueling facility shall be at least 100 feet from any building, public road or above ground fuel storage tank. See UFC 3-460-01 –“Design: Petroleum Fuel Facilities” for additional siting restrictions with respect to electromagnetic radiation.

121 30 AIRCRAFT DEFUELING FACILITY (GM)**FAC: 1242****BFR Required: N**

This Category Code shall be used for inventory of existing facilities only. Aircraft shall be defueled into tank trucks designated for that purpose.

121 50 AIRCRAFT READY FUELS STORAGE (BL)**FAC: 1241****BFR Required: Y**

Note: Previously listed as Category Code 124 30 AIRCRAFT READY FUELS STORAGE

12150-1 **DESCRIPTION.** Aircraft ready fuel storage provides an operation and reserve supply of aviation gasoline and jet fuel. At air installations all aviation fuel storage shall be categorized as ready fuel storage as opposed to depot level storage; see 411 Category Code series. Aircraft ready fuel storage may be classified as local or remote. The remote are usually designated as the station's fuel farm and provide the majority of the storage capacity. Local storage refers to those storage tanks located close to a fuel dispensing facility. Local storage tanks (or day tanks) can be refilled overnight thereby permitting the use of a smaller diameter pipeline from the remote tanks to the local storage and dispensing area. Local storage such as day tanks should be used settlement prior to dispensing.

12150-2 **CRITERIA.** The fuel storage requirement must be determined by an engineering analysis. The Fleet Fuels Officer, Code N413F, within the US Fleet Forces Command in collaboration with Defense Logistics Agency's (DLA) Defense Energy Support Center (DESC) Code B (Bulk Fuels) will determine the fuel storage requirement. The requirement is a function of: the number and type of aircraft supported, aircraft fuel consumption rates, and the number of hours of flown. At CONUS installations, a ten-day supply is normally provided. At OCONUS installations, a thirty-day supply may be provided. The above days of supply requirements are guidelines and may be modified to reflect restricted or unpredictable fuel delivery schedules. When both local and remote storage are provided, the remote storage capacity requirement shall be reduced by 50% of the tank capacity provided by local storage. See Figure 12150-1 for a sample calculation.

Figure 12150-1. Example Requirement Calculation

<p>Given: (1) CONUS 10 day requirement = 500,000 GA (2) 50,000 GA of local storage is being provided</p> <p>Remote Storage = 500,000 GA – {50% x (local storage)} = 500,000 GA – {0.50 x (50,000 GA)} = 500,000 GA – 25,000 GA = 475,000 GA</p> <p>Total (121 50) Requirement = local + remote = 50,000 GA + 475,000 GA = 525,000 GA</p>

12150-3 **SITING.** Fuels storage tanks must be separated from each other, buildings, property lines, roads, railroads lines, and power lines. The fuel farm layout, design and siting are available in the Unified Facilities Criteria Design: Petroleum Fuel Facilities (UFC 3-460-01 dated 16 Jan 2004).

122 MARINE FUEL FACILITIES

122 10 MARINE FUELING FACILITY (GM)

FAC: 1221

BFR Required: Y

Design Criteria: refer to UFC 3-460-01: "Design: Petroleum Fuel Facilities"
(replacement for NAVFAC Design Manual DM-22)

12210-1 **DESCRIPTION.** A marine fueling facility is designed for small vessels and capital ships and should be able to refuel the largest ship that can dock at the station's waterfront. The facility may have the outlets located on a general purpose berthing pier, a combined cargo and fueling pier or on a separate fueling pier, depending on the station's mission, logistics, and base location.

12210-2 **ADDITIONAL REQUIREMENTS.** In addition to the pier outlets, the facility has a piping approach trestle, a pumping station, security fencing, hose racks, access roads, fire protection and ready marine fuel storage tanks. Surge storage tanks, if required, are categorized under code 124-70 and bulk marine fuel storage tanks are categorized under code 411-10, Ship Fuel Storage. Fuel piers or wharves will vary greatly according to the services required. Some may be of the simple type having one ship berth and a minimum-size dock platform to the more elaborate pier head or finger-type having two or three ship berth all provided with the appropriate fuel bunkering connections.

12210-3 **SEPARATION DISTANCES.** There should be 1,800 feet between tankage and the nearest station structure or boundary fence. Consideration must be given to safe distances from other buildings and facilities.

122 20 SMALL CRAFT FUELING STATION (GM)

FAC: 1221

BFR Required: Y

Design Criteria: refer to UFC 4-150-01 "Piers and Wharves"

12220-1 **DESCRIPTION.** A small craft fueling station is used to refuel such small craft as crash boats and administrative boats. It shall include dispensing pedestal-type commercial pumps, piping, tanks, hoses, floodlights and grounding devices, electrical power, and fire protection.

12220-2 **CAPACITY.** There will be at least one separate pump for each grade of fuel used and each shall have a minimum backup storage of 5,000 gallons. The station will normally dispense a minimum of two grades of gasoline and diesel fuel and shall have sufficient capacity to service three boats simultaneously. This may be modified to conform to the type and number of small craft serviced.

12220-3 **SITING.** The small craft fueling station, except for the storage tanks, is a part of the Small Craft Berthing facility. It is acceptable to locate fuel storage tanks in remote areas. The spacing of these tanks will be in accordance with criteria set forth in See Category Code 122 30 for additional fuel storage information.

122 30 SMALL CRAFT READY FUEL STORAGE (GA)

FAC: 1242

BFR Required: Y

Note: Previously listed as Category Code 124 40 SMALL CRAFT READY FUELS STORAGE

12230-1 **DESCRIPTION.** A marine ready fuel storage tank is the ready issue operation storage of a particular grade of fuel for small boats and yard craft. These boats will include small tugs, security boats, repair barges, etc. The boats may be operated by several different departments within or tenants operating at the installation including: Public Works, Base Security, Naval Coastal Warfare Command, Amphibious Group Two, Naval Special Forces Command, etc. Large ships will refuel at depot fueling piers or via fuel barges. For depot level fuel storage see Category Code 411. See Category Code 122 20 (Small Craft Fueling Station) for the fuel dispensing facility which includes commercial fuel pumps, piping from the tank to the pump, hoses, floodlights, and other equipment for dispensing the fuel.

12230-2 **CRITERIA.** The fuel storage requirement must be determined by an engineering analysis. The Fleet Fuels Officer, Code N413F, within the US Fleet Forces Command in collaboration with Defense Logistics Agency's (DLA) Defense Energy Support Center (DESC) Code B (Bulk Fuels) will determine the fuel storage

requirement. The requirement is a function of: the number and type of boats supported, fuel consumption rates, and the number of hours of driven. At CONUS installations, a ten-day supply is normally provided. At OCONUS installations, a thirty-day supply may be provided. As minimum, the ready fuel storage will be one 5,000-gallon gasoline tank for each octane grade and one 5,000-gallon diesel fuel tank. The tanks will include the piping for fuel delivery to the tanks, pumps for pumping fuel into the tanks, tank security fencing, tank fire protection, and paving for fuel delivery, as required.

12230-3 **SITING.** Fuels storage tanks must be separate from each other, buildings, property lines, roads, railroads lines, and power lines. The fuel farm layout, design and siting are available in the Unified Facilities Criteria (UFC) 3-460-01 "Design: Petroleum Fuel Facilities".

123 LAND/GROUND VEHICLE FUELING/DISPENSING FACILITIES

123-1 This Category Code group is for facilities serving official government land vehicles and equipment only. If NEX operates the facility, see Category Code 740-30/31, Exchange Service and Auto Repair/Supplemental Gasoline Station. For Aviation Fueling and Dispensing, see Category Code Series 121. For Marine and Small Craft Fueling and Dispensing, see Category Code series 122. For bulk fuel storage such as tank farm installation, see Category Code series 411.

123 10 FILLING STATION (OL)

FAC: 1231

BFR Required: Y

12310-1 **DESCRIPTION.** A filling station is a fueling facility for official vehicles and equipment on Navy and Marine Corps installations. This Category Code applies to pump outlets including the covered islands that support the pump outlets, the concrete parking area, lighting and the access paving to the pumps/islands.

12310-2 **ITEMS INCLUDED IN STATION.** In the event the installation still has a filling station, the following items will be included:

- Three dispensing pumps (Outlet – OL) for each 250-gasoline engine vehicles in the official motor pool:
 1. One pump for gasoline that can dispense each of the three of standard octane grades gasoline (low, medium, high octane if required)
 2. One pump for diesel fuel
 3. One pump for other fuel if needed (i.e., leaded fuel if required, etc.)
- Allowance for associated safety and environmental equipment

12310-3 **EXCLUSIONS.** This Category Code excludes the fuel storage tanks and filling station building; see Category Code 123 30 for tank storage and Category Code 123 15 for shelter.

123 15 FILLING STATION BUILDING (SF)

FAC: 1444

BFR Required: Y

12315-1 **DESCRIPTION.** This code is used for reporting the administrative shelter associated with a filling station. If the filling station is operated by a private entity, then use the 740-30/31 Category Codes. Where credit card systems are used and operators are not needed, a shelter is not required. A shed may be provided to protect or house equipment.

12315-2 **REQUIREMENT.** This code should also include the following:

- Minimum size shelter is 6’x6’
- Control/monitoring room area
- Access road and 400 SF of pavement at each pump with appropriate curbing for spills and containment
- Area lighting and signage

123 16 OVERHEAD COVER, AIRFIELD (SF)

FAC: 1459

BFR Required: N

12316-1 **DESCRIPTION.** This category code was created for inventory purposes. It can be used for overhead covers located on the airfield (that are not classified as equipment).

123 17 OVERHEAD COVER, MISCELLANEOUS (SF)

FAC: 1459

BFR Required: N

12317-1 **DESCRIPTION.** This category code was created for inventory purposes. It can be used for overhead covers located at the main gates of installations, overhead covers atop gas pumps, and any other time that an overhead cover is used.

123 30 VEHICLE AND EQUIPMENT READY FUEL STORAGE (GA)**FAC: 1243****BFR Required: Y**

Note: Previously listed as 124 50 VEHICLE READY FUEL STORAGE

12330-1 **DESCRIPTION.** This code is used for reporting the tank storage requirement associated with Category Code 123 10 and 740 30, including those tanks in remote locations that are considered Real Property.

NOTE: Tanks that are skid mounted and/or designed to be moved to various locations are considered equipment. Tanks that are provided by vendors are also considered equipment. This Category Code does not apply to equipment.

12330-2 **NUMBER OF TANKS REQUIRED.** One tank for each grade of fuel required (low, medium, and high-octane fuels; diesel fuel; and other fuels as required).

12330-3 **STORAGE CAPACITY.** The total amount of storage capacity in each station should be twice the capacity of all fuel tanks of vehicles and equipment assigned to an activity.

12330-4 **MINIMUM NUMBER OF GALLONS.** Service station tanks should be a minimum of 5,000 gallons unless approved by Service Headquarters. For other tanks, such as heating fuel, small tanks may be used.

12330-5 **ADDITIONAL REQUIREMENTS.** In addition, there should be a 10-day total storage capacity for CONUS bases and a 30-day total capacity for overseas bases. This total storage should be based on high average such as winter months for heating oil. Location of base and access to fuel resources as well as current delivery schedules should be considered when developing this immediate backup fuel requirement. Don't forget to include emergency generators for buildings and utilities that may be needed in a hurricane or other base emergency. Some of these generators and equipment may have service contracts (i.e., utilities privatization, etc.) that should not be included in these calculations. A good resource for the rate of consumption information is the historical accounting and billing records. If records are not available, provide 32 gallons per vehicle for each type of fuel used at overseas bases. Equipment requirements will vary.

12330-6 **ALTERNATE UNIT OF MEASURE.** Barrels (BL) may be used as an alternative unit of measure.

12330-7 **EXCLUSION.** For fuel oil or heating fuel see Category Code 126 15 Petroleum Fuel Storage Facility.

123 40 ETHANOL READY FUEL STORAGE (GA)**FAC: 1243****BFR Required: Y**

12340-1 **DESCRIPTION.** This category is for alternative fuel facilities in support of ethanol operation of vehicles.

123 50 BIODIESEL READY FUEL STORAGE (GA)

FAC: 1243

BFR Required: Y

12350-1 **DESCRIPTION.** This category is for alternative fuel facilities in support of biodiesel operation of vehicles.

125 POL DISTRIBUTION / PIPELINE FACILITIES

125-1 This category is for pipelines and accessory equipment between tank farms and operating fuel storage facilities and intermediate points.

125 10 POL PIPELINE (MI)

FAC: 1251

BFR Required: N

12510-1 **DESCRIPTION.** Separate fuel lines should be used for each type of fuel stored at the activity. Underground pipelines are preferred and should be used wherever practical, therefore eliminating thermo-solar effects. In some instances, subaqueous pipelines will be required for crossing harbors or through marshy areas. Submarine pipelines have specific design requirements unique to sub refueling. This category will include in-line fuel filtering systems, sensors, alarms, manifolds, area lighting for the pipeline, paving and piers. A surge tank is required for pipeline systems; see Category Code 125 30.

12510-2 **GENERAL PLANNING NOTES.** The capacity and size of the pipeline will have a direct impact on rate of flow as well as exposure to temperature changes. The design criteria are provided in the Unified Facilities Criteria Design: Petroleum Fuel Facilities (UFC 3-460-01 dated 16 Jan 2004). In distributing fuel oil, large pipelines are preferred. Whenever crossing private property be sure to include access roads and maintenance areas paralleling the pipeline. The maintenance area should not be less than 16 feet wide. Daily consumption, storage requirements, delivery schedules, length of delivery, and thermo-solar effects should all be considered when designing POL pipeline. Only the length of the POL is needed for this category requirement. Looped systems are preferred, so be sure to add this to total length of the pipeline. The loop will provide flexibility, reliability and contributes to product cleanliness as well as reduce the magnitude of hydraulic shock.

125 16 POL PIPELINE PUMP STATION AND ANCILLARY EQUIPMENT (EA)**FAC: 1262****BFR Required: N**

12516-1 **DESCRIPTION.** This Category Code includes pumping stations and ancillary equipment used to move the fuel through the pipes. This facility may also include controls, gauges, meter, lighting, fire protection, and ventilation. An alternative unit of measure may be cubic feet per minute (CM). Underground pump stations are preferred around runways.

125 20 SHED/SHELTER FOR PUMP STATION AND ANCILLARY EQUIPMENT (SF)**FAC: 1459****BFR Required: N**

12520-1 **DESCRIPTION.** This code is for the building or structure housing pumping stations and ancillary equipment.

12520-2 **REQUIREMENT.** Facility should be large enough to house or shelter equipment with ample space allow performance of maintenance to housed equipment. Typically 2 - 4 feet of clearance is adequate. In lieu of net to gross factor, add in wall thickness if facility is enclosed.

125 21 POL PIPING-SINGLE SITE (LF).**FAC: 1252****BFR Required: N****125 30 SURGE STORAGE (GA)****FAC: 1244****BFR Required: N**

Note: Previously listed as Category Code 124 70 SURGE STORAGE

12530-1 **DESCRIPTION.** A surge tank is used where there is a risk of hydraulic shock. Hydraulic shock can occur when the pump used to deliver fuel is greater than the pipeline capacity; unloading rate of the delivery tanker/barge exceeds the rate of the shore pumping system; or water, air or other blockage occurs in the pipeline. One surge tank is required each type of fuel. The size of the surge tank will be determined by the size of the tanker unloading at the facility and the capacity of shore booster pumps. UFC 3-460-01 suggests computer modeling to determine need and tank size.

126 OTHER LIQUID PETROLEUM PRODUCTS FACILITIES

126-1 Use this Category Code for liquid fuel or petroleum products facilities not specifically related to aviation, marine craft, or ground vehicle fuel requirements (see Category Codes series 121, 122, and 123, respectively). Use Category Code 821 60 or 821 61 for heating plant fuel storage. This Category Code includes fuel loading and

unloading; drum storage, loading and maintenance; and miscellaneous fuel storage (i.e., heating fuel, kerosene, propane, fuel oil, etc.). See Category Code series 411 for depot level storage.

126 10 DRUM AND CAN LOADING FACILITY (SF)

FAC: 1261

BFR Required: Y

12610-1 **DESCRIPTION.** A drum and can loading facility is a fuel facility equipped to fill drums with fuel oil, diesel, kerosene, jet engine fuel, motor gasoline, aviation gasoline, and lubricating oils. The facility may also be provided with a drum reconditioning plant. Drum storage areas may also be needed. Drums with varying fuel may be stored in one storage area. Others may be separated; see Unified Facilities Criteria Design: Petroleum Fuel Facilities (UFC 3-460-01 dtd 16 Jan 2004). There may be one storage area for empty drums and another storage area for filled drums. The drums have 55-gallon capacity. This facility should not be used for storage of contaminated fuel or waste oil ready for disposal; see hazardous waste facilities under Category Codes 831 41 and 831 42.

12610-2 **STORAGE.** Jet engine fuel and gasoline drums shall be stored outside in designated compounds. Special construction features will be required if an outside compound is not available. Drummed products with a flash point of 100 degrees Fahrenheit shall contain no more than 5,000 drums. Drummed products with a flash point above 100 °F may be stored in groups of 10,000 or less. When possible, racks and pallets should be used to reduce the footprint utilized to store drums.

12610-3 **WORK PLATFORMS.** The drum filling area shall include a work platform covered with an open shed. A separate platform shall be used for each type of fuel with individual pipelines for each of the various fuel types. The pipeline will run from the storage tank to a fuel manifold to the outlet (see Category Code 126 15 for storage tank). Each platform will have 2 outlets, spaced at 10-foot intervals. A mechanical drum conveyor system or equipment may be used to carry the drums, depending on the size of the operation.

12610-4 **SMALLER QUANTITIES.** For smaller operations where the fuel products are delivered in drums, only a small fuel/petroleum storage area may be required to hold a limited number of drums; in this case, use Category Code 441 30. For very small quantities, a hazardous material storage locker may be used.

126 15 PETROLEUM READY FUEL STORAGE FACILITY (GA)

FAC: 1244

BFR Required: Y

Note: Previously listed as Category Code 124 20 DRUM AND CAN READY FUEL STORAGE and Category Code 124 65 ACTIVITY HEATING FUEL STORAGE

12615-1 **DESCRIPTION.** This category shall be used for the storage of petroleum products used to fill drums as provided in Category Code 126 10, heating oil tanks (see Category Code 821-60 or 61 for heating plant fuel storage), lube oil tanks, grease, propane tanks, or fuel storage tanks for generators and other equipment. This Category Code should not be used for those items included in Category Code series 121, 122, and 123.

12615-2 **REQUIREMENT.** The normal storage for CONUS would be a 10 day supply and for OCONUS a 30 day supply. Historical annual data may be used to determine average daily consumption, then multiply that times the number of days supply needed to get the total storage requirement for each type of petroleum product stored. For storage tanks associated with one piece of equipment such as a building generator, sewage pump station or building heater, check equipment specifications and emergency requirements. Some facilities or activities may have specific hurricane or other emergency requirements that should be taken into consideration. If this activity has a drum loading facility, the size and number of drums should be added to the storage requirements for each type of fuel or petroleum product. Design should factor in fuel delivery schedules and availability. If emergency requirements dictate, additional storage may be required.

12615-3 **ALTERNATIVE UNIT OF MEASURE.** The alternative unit of measure is gallons, (GA).

126 30 TANK TRUCK TANK CAR LOADING FACILITY (OL)

FAC: 1261

BFR Required: Y

12630-1 **DESCRIPTION.** This Category Code applies to a tank truck loading facility (either a truck fill stand or stands) that dispense fuels other than aircraft fuels to delivery trucks. (For information on an aircraft truck fueling facility, see Category Code 121 20.) Each stand has one dual outlet, a meter, static line, platform, roadway, strainer and necessary valves, piping, pump, and electrical controls. For design criteria, see UFC 3-460-01.

12630-1.1 **Outlet Requirements.** A tank truck loading facility is required at those installations without contract refueling and automotive ready fuel storage facilities. There shall be at least one outlet for each grade of fuel, capable of dispensing fuel at the rate of 250 to 600 gallons per minute. The total number of outlets will vary with the station population, mission, and the number of fuels used. A tank truck loading island is 38 feet 9 inches long by 6 feet 0 inches wide.

12630-2 **PROVIDING FOR MULTIPLE TYPES OF FUEL.** Facilities for issue of fuel by tank car shall be provided when specified by NAVFAC. The fuel normally issued will be jet engine fuel and gasoline, but diesel fuel oil and other fuel oils may be included. Separate pipe lines shall be provided from the storage tanks for each type of fuel.

12630-2.1 **Railroad Siding and Sludge Transfer Disposal.** The normal installation will provide for a railroad siding to each side of the loading island with a length to accommodate six cars on each side. A tank car issuing facility may also be used for disposal of sludge from storage tanks, and for this purpose special pipe lines to the facility shall be provided for sludge transfer.

12630-2.2 **Rate at Which Facilities Will Provide for Receipt of Fuel.** Tank cars are generally of 8,000- and 10,000-gallon capacity. However, there are some tank cars of 12,000-gallon capacity.

126 40 TANK TRUCK/TANK CAR UNLOADING FACILITY (OL)

FAC: 1261

BFR Required: Y

12640-1 **DESCRIPTION.** A tank car unloading facility unloads liquid products from tank cars. Each facility has static lines, strainer, access road, security fencing, lighting, necessary valves, piping, pump, electrical controls, and a shelter structure for use of accounting and/or control house. For design criteria, see UFC 3-460-01.

12640-2 **REQUIREMENT.** The number of cars to be accommodated at an unloading facility shall be determined by a survey. There will be one unloading connection for each car. The tank car unloading facility will provide 400- to 800-gallon fuel transfer rate between each tank car and storage.

12640-3 **QUANTITY OF TANK TRUCK UNLOADING FACILITIES.** Tank truck unloading facilities shall be determined by a survey. Facilities should be capable of handling the entire daily fuel requirements in 8 hours. Where unloading facilities by railroad tank cars are available, paved aprons should be provided adjacent to sidings so pumping facilities may serve both tank cars and tank trucks.

131 COMMAND, CONTROL, COMMUNICATIONS, COMPUTERS, COMBAT SYSTEMS, INTELLIGENCE, SURVEILLANCE, AND RECONNAISSANCE (C5ISR) BUILDINGS

131-1 **DEFINITION.** This group of shore facilities supports the reception, processing, distribution, and/or transmission of classified and unclassified voice, data, and video communications in support of the Navy and Marine Corps organizations. Table 131-1 provides a matrix identifying which types of C5ISR functions are best represented for each category code.

Table 131-1. Category Code Functional Space Matrix

Function/Command	131 15	131 24	131 35	131 40	131 50	143 65	143 80
Base Communications Office	X						
Information Technology Office	X						
Data Center or Server Center	X						
Navy Information Operations Command (NIOC)	X						
Naval Computer and Telecommunications Station (NCTS) / Naval Computer and Telecommunications Master Area Station (NCTAMS)	X						
Satellite Communications (SATCOM)		X					
Receiver/Transceiver Function			X				
Unmanned Telecommunications Distribution				X			
Transmitter Function					X		
Region/Installation Operations Center						X	
Mission Operation Command and Control							X
High Density Computing Center	X						

131-2 **REQUIREMENT PROCESS.** Unless otherwise specified, the following requirements process should be utilized when planning C5ISR buildings. C5ISR buildings are unique in that they are specifically tailored to a Navy or Marine Corps activity. As a result, engineering evaluations, manning, and equipment configurations may also be required. This information should be used with the guidance provided below to determine the basic facility requirements.

131-3 **SECURITY.** Security issues and operational efficiencies may result in the co-location of office space, equipment space, associated maintenance space, and other associated support/storage space within respective commands.

131-4 **RESILIENCY.** The design of buildings and infrastructure to withstand, absorb, or avoid damage without suffering catastrophic failure is critical to C5ISR

facilities. C5ISR facilities must be planned to provide the appropriate level of continuity of operations based on the individual mission of the tenant. There are three facets to the resiliency of C5ISR facilities: Tier Classification, Survivability, and Antiterrorism/Force Protection. All three of these facets must be addressed in basic facility calculations, facility design, and project cost estimating.

131-4.1 Tier Classification. The Tier Classification system, as defined by the Uptime Institute, is used to identify the appropriate redundancy requirements for power, cooling, maintenance, and capability to withstand a failure. Planning criteria should address any additional space requirements based on the Tier level required. The Tier Classification system is further described in the “Tiers Standard Topology” available at the Uptime Institute website:

<https://uptimeinstitute.com/resources/asset/tier-standard-topology>

131-4.2 Survivability. Survivability is the ability of the overall building to withstand failure due to natural disaster such as earthquakes, hurricanes, tornados, flooding, and sea level rise - all of which are dictated by the climate in the geographic location of the existing or proposed facility.

131-4.3 Antiterrorism/Force Protection (AT/FP). The facility must be planned to meet antiterrorism and force protection requirements as identified in UFC 4-010-01, DoD Minimum Antiterrorism Standards for Buildings and UFC 4-010-02 DoD Minimum Antiterrorism Standoff Distances for Buildings.

131-5 FUNCTIONAL AREAS. C5ISR facilities may contain the following functional areas: General Administrative Space, Special Purpose Space, C5ISR Operations Space, Maintenance Space, Training Space, Equipment Space, and IT Logistics Support Space.

131-6 PERSONNEL LOADING. All C5ISR BFRs should be based on an official personnel loading source, projected loading year, and associated personnel loading. The official personnel loading analysis must be provided separately to support the requirement. The personnel loading document should include all assigned billets to include: military (including reservists), civilians, students, and contractors. Each billet should be assigned a space type of: private office, cubicle, shared, or special as defined below:

131-6.1 Private Office. Personnel that are entitled to an office include supervisory personnel or special billets that require privacy such as a legal officer or financial manager. See section 131-7.1 for calculation criteria.

131-6.2 Cubicle. Personnel that require a non-operations workspace but do not require a private office as stated in section 131-6.1 are assigned cubicles. See section 131-7.2 for calculation criteria.

131-6.3 Shared. Personnel assigned to watch sections are assigned to shared workstations, which are provided based on the watch stations required, not the total personnel assigned. Personnel that work in the maintenance spaces are also

assigned to shared areas. The quantity of workstations required is calculated using the number of positions in the Watch Center and/or the number of workstations required to support the maintenance function. See Sections 131-9.1, "Watch Center" and 131-10 "Maintenance Space" for calculation criteria.

131-6.4 **Special.** Personnel that conduct analysis or operations functions that require space greater than that allotted by a cubicle are assigned the category of "Special", see Section 131-9.2 "Analysis Operations" for calculation criteria. This space type is also used to classify specific billets such as the Special Security Officer, which is provided a specific space allotment under Section 131-8, "Special Purpose Space".

131-7 **GENERAL ADMINISTRATIVE SPACE.** General Administrative Space types are justified to support administrative or similar functions. They include: private and open office spaces.

131-7.1 **Private Office.** Private Offices are typically provided for supervisory and other personnel based upon specific job requirements. These offices typically have full-height walls, or partitions, from finished floor to finished ceiling.

Planning factor: Allocate 120 NSF/PN requiring Private Office space.

Justification: Private Offices are justified for supervisory personnel or for those positions whose job duties require privacy such as legal or financial officers.

131-7.2 **Open Offices.** Open Offices are programmed and designed to incorporate modular workstations, which are typically occupied by general administrative and/or functional support staff. Personnel assigned as requiring a cubicle per the personnel loading are assigned to Open Office space.

Planning factor: Allocate 64 NSF/PN requiring Open Office space.

131-8 **SPECIAL PURPOSE SPACE.** Special Purpose Spaces are additive and must be individually justified in support of specific missions or functions. For C5ISR missions, the following Special Purpose Spaces may be authorized with justification.

131-8.1 **Special Purpose Space – Basic.** Basic Special Purpose Spaces include allowances for Administrative Support, Auditorium, Break Room, Break Room Kitchen, Classified Material Storage (CMS) Vault, Conference/Training Rooms, Duty/Bunk Room, Mailroom, and Technical Publications Area.

131-8.1.1 **Administrative Support Space.** This space supports the administrative functions and includes the following:

- Conference room equipment storage (e.g. AV equipment, chairs, lecterns, tables)
- Day lockers
- Group file storage (excluding individual file storage provided within modular furniture)
- Lactation room(s)

- Office equipment and supply storage
- Reception area(s)

Planning factor: Allocate 8 NSF/PN requiring Administrative Support Space.

131-8.1.2 **Auditorium.** A large area performing the function of an auditorium may be required for commands with more than 250 personnel. The size of this area is dependent on the staffing and size of the organization.

Planning factor: Allocate 150 NSF plus 10 NSF per seat based on the largest department of the command.

Justification: An Auditorium may be justified under special circumstances.

Justification should address some or all of the following factors as appropriate:

- Mission or functions performed
- Size of organization is greater than 250 personnel
- Other justification

131-8.1.3 **Break Room.** A Break Room w/o Kitchen is a staff-only space, used for breaks and lunches. It typically includes some or all of the following: coffee bar, microwave oven, MWR drink/snack space, refrigerator, water cooler.

Planning factor: Allocate 2 NSF/PN assigned.

131-8.1.4 **Break Room Kitchen.** A full kitchen may be provided, with justification, if a command has 24-hour operations or if the facility is located in a remote location with no food service options available on-site or near by. A Break Room Kitchen is a staff-only space. It may include some, or all, of the following: coffee bar, cupboards, microwave, refrigerator, stove, sink and meal preparation space.

Planning factor: Allocate an additional space for a kitchen equal to one third of the total Break Room requirement, up to a maximum of 150 NSF. This area is considered an additional requirement above and beyond the total Break Room requirement.

Justification: A Break Room Kitchen may be justified for operational functions.

Justification should address some or all of the following factors as appropriate:

- Mission or functions performed
- Distance from food service facilities
- Other justification

131-8.1.5 **Classified Material Storage (CMS) Vault.** A CMS Vault is a secured area for handling classified material. For C5ISR functions, this type of facility is only provided when the primary facility is unclassified and intermittent access to classified materials and networks is required. Additionally, this space is not intended to be the primary workspace for any staff. It may include a worktable at 50 NSF and up to a maximum of 5 workstations at 64 NSF each. The number of workstations required must be provided by the organization for which the space requirements (BFR) are being prepared.

Note: If a portion of an organization operates at a higher classification than the rest of the facility, the space provided for them is calculated based on the overall requirements set forth in the 131 Introductory Criteria with an additional justification provided indicating the requirement for any additional physical separation, construction requirements, and security requirements.

Planning factor: Allocate 50 NSF (for a worktable) and up to a maximum of 5 workstations at 64 NSF, each based on specific requirements of the organization.

Justification: A CMS Vault room may be justified for various organizations or functions. Justification should address some or all of the following factors as appropriate:

- Mission or functions performed
- Number of workstations required
- Number of vaults required (if more than one)
- Other justification as necessary

131-8.1.6 Conference/Training Rooms. Conference/Training Rooms provide space for staff meetings, briefings, and training sessions. The total allocation may be adjusted in terms of number and size of conference rooms to meet organizational needs.

Planning factor: Allocate total NSF space requirement based on the Conference Room Table 61010-1.

131-8.1.7 Duty/Bunk Room. A Duty/Bunk Room is required when the mission requires 24 hours a day, 7 days a week operations.

Planning factor: Allocate 130 NSF for a Duty/Bunk Room.

Justification: A Duty/Bunk Room may be justified for any C5ISR function with an overnight watch that requires overnight accommodations for the duty officer and requires approval from the Installation Commanding Officer. Justification should address some or all of the following factors as appropriate:

- Mission or functions performed
- Watch schedule
- Other justification

131-8.1.8 Mailroom. A Mailroom accommodates processing and distribution of the facility's incoming and outgoing mail and parcels. It may accommodate screening requirements as necessary based on security requirements. Ensure adequate storage and work space. The mail room should be adjacent, and provide direct access, to the shipping/receiving area. A mail room must be individually justified for operational, site specific or other reasons such as large size of organization.

Planning Factor: Allocate 40 NSF for every 50 personnel assigned.

Justification: Address some or all of the following factors as appropriate:

- Mission or functions performed.
- Size of organization - Is organization large enough to warrant its own mail room rather than rely on the host installation's centralized postal facility?
- Location of organization - Does geographic separation of the organization from the host installation site warrant a standalone mailroom?
- Security - Do security requirements warrant a mail room?
- Mail room hours of operation (e.g., full-time or part-time)
- Other justification

131-8.1.9 **Technical Publications Area.** A Technical Publications Library provides ready access to technical manuals, handbooks, and other guidance.

Note that the need for technical/legal/other libraries has diminished as many resources are now readily available online; however, some functions still require access to printed publications.

As a space saving measure, consider combining technical libraries with small conference/training rooms, rather than providing a separate allocation. This area may be required to store reference publications and literary data. It is configured similar to a reference library and contains bookshelves, a reference area, and a working space for a minimum of two people. This requirement must be justified based on mission operational requirements.

Planning Factor: Allocate 300 NSF.

Justification: A Technical Publications Library may be justified for technical components or divisions of an organization. Justification should address some or all of the following factors as appropriate:

- Mission or functions performed
- Function(s) supported (e.g., architecture, engineering, legal, other)
- Number and size of technical libraries required
- Other justification

131-8.2 **Special Purpose Space – Fitness, Locker, and Shower.** Fitness Rooms, Locker Rooms, and Shower Rooms may be authorized as described below:

131-8.2.1 **Fitness Room.** A Fitness Room is a space specifically designated for exercise, fitness training, and physical wellness activities. Fitness Rooms are only allowed in accordance with CNICINST 1710.1, whereby an organization has more than a 15 minute commute by vehicle to the nearest Morale Welfare and Recreation (MWR) Fitness Center or if active duty personnel are required to be on station and unable to leave for 18 hours at any given time. A fitness room must also have approval from the Installation Commanding Officer. If approved, calculate the requirement separately under Category Code 740 45 Fitness Room.

131-8.2.2 Locker Room. A Locker Room provides individual secured storage space for a change in clothing and other personal belongings. Lockers are authorized in support of 24-hour, multiple shift operations. Lockers may also be authorized in support of military physical training requirements at remote locations, without access to fitness centers.

- When lockers are authorized in support of 24-hour, multiple shift operations, one locker, for every 10 PN based on the largest shift, should be provided.
- When lockers are authorized in support of physical training requirements for military personnel at remote locations without access to fitness centers, one locker for every 20 military personnel assigned should be provided.
- If the locker room is required due to overseas operations, where personnel are not allowed to travel to and from the installation in uniform, 1 locker per military staff is allowed with Installation policy provided as justification.

Use the guidance above to determine the number of lockers required.

Planning Factor: Allocate 8 NSF/Locker each.

Justification: A Locker Room may be justified to support physical training requirements for military personnel, and may be applicable to certain personnel that do not occupy a dedicated workspace, such as security personnel or workstation operators working in shifts. Justification should address some or all of the following factors as appropriate:

- Mission or functions performed
- Type of operations supported (normal, shift, emergency)
- Physical Training (PT) requirements at remote locations
- Overseas Installation uniform policy
- Type of locker space required (e.g., shared, dedicated, other)
- Types of personnel that require locker space (e.g., military, civilian, or contractor personnel)
- Types of personnel that require locker space (e.g., military, civilian, or contractor personnel). Military personnel may require locker space in support of mandatory physical fitness requirements. Military, civilian and/or contractor personnel may require locker space in support of shift or emergency operations. Other (e.g. security) personnel that do not occupy a dedicated work space, may require locker space.
- Other justification

131-8.2.3 Shower Room. A Shower Room provides one or more shower stalls and is typically collocated with a locker room and/or bathroom. Showers are authorized in support of critical 24-hour, multiple shift operations. Showers may also be authorized in support of military physical training requirements at remote locations without access to fitness centers.

- When showers are authorized in support of 24-hour, multiple shift operations, one shower for every 10 PN, based on the largest shift, should be provided.

- When showers are authorized in support of physical training requirements for military personnel at remote locations without access to fitness centers, one shower for every 20 military personnel assigned should be provided.

In both cases, a ratio of 80/20 (male/female), should be used for planning purposes (ratio may go up as manning structure dictates, but not lower than 80/20). Use the guidance above to determine the number of showers required.

Planning Factor: Allocate 20 NSF/shower.

Justification: A Shower Room may be justified for commands with 24-hour, multiple shifts or remote operation requirements. If the organization is located on a large installation with access to fitness centers, shower rooms are generally not authorized except when 24-hour operations are required.

Justification should address some or all of the following factors as appropriate:

- Mission or functions performed
- Type of operations supported (normal, shift, emergency)
- Physical Training (PT) requirements at remote locations
- Total number of showers required based on guidance above
- Military personnel may require showers in support of mandatory physical fitness requirements.
- Military, civilian and/or contractor personnel may require showers in support of shift or emergency operations.
- Other justification

131-8.3 Special Purpose Space, Security. Security spaces for C5ISR facilities include the Entry Control Area and the Special Security Office Suite.

131-8.3.1 Entry Control Area. This multifunctional area provides an assembly or holding area for visitors awaiting escort, badge and pass issue and verification, and is considered the central point for ingress and egress. For unclassified facilities, this area should consist of up to two workstations, for a two-person watch, and up to 100 NSF waiting area for personnel.

For general planning purposes, facilities that have classified spaces will require larger Entry Control Area that supports two stations for a two-person watch, a waiting area that accommodates mantraps, one unisex restroom, and a waiting area. Additionally, this area should include an additional 20 NSF per every 50 personnel assigned to the organization to accommodate the transit of personnel through the Entry Control Area.

Planning Factors: For each area within the Entry Control area, allocate as follows:

- Security Entry Control Area. Allocate 1 entry control area at 100 NSF plus 20 NSF per every 50 personnel in the command.
- Secure Visitor Waiting Area. Allocate one secure waiting area at 120 NSF.

- Security Watch Station. Allocate 64 NSF per workstation (max of 2 workstations).
- Security Unisex Bathroom. Allocate one unisex bathroom at 60 NSF, allowed only if command population exceeds 500 PN in a single facility.
- Security, Other Space. Allocated as needed for other security requirements (e.g. Security Systems Monitoring). Provide appropriate Engineering Evaluation and justification.

Justification: Justification should address some, or all, of the following factors as appropriate:

- Mission or functions performed
- Security requirements
- Other justification

Note: Refer to requirements for classified facilities requiring more stringent security requirements and specific design guidance such as: Open Storage Secret (OSS), Sensitive Compartmented Information Facility (SCIF), Special Access Program (SAP) and Top Secret/Sensitive Compartmented Information (TS/SCI).

131-8.3.2 Special Security Officer (SSO) Suite. The SSO Suite may be required depending on the following TS/SCI classification level:

- If SCIF or SAP facilities are present
- If personnel within the command maintain clearance levels

The SSO Suite is a multifunctional area containing, but not limited to, a reception area, indoctrination area, photography area, vault, and the SSO office space. The required area varies based on the size of the command. Large commands require additional space to handle a larger volume of personnel that need to be processed. A minimum allowance of 350 NSF is provided for all commands up to 100 personnel. Medium and large sized commands are provided additional area as shown in Table 131-2.

Note: The SSO Suite provides office area for the SSO but does not provide office space for any additional staff. SSO staff should be provided cubicle space as a part of the open office calculation, see Section 131-6. Alternatively, since the SSO office is included in this calculation, a private office should not be included in the private office calculation for the SSO.

Table 131-2. SSO Suite Allowances

SSO Suite Command Size	Total Max NSF
Small (< 100 PN)	350
Med (100-500 PN)	450
Large (>500 PN)	600

131-9 **C5ISR OPERATIONS SPACE.** C5ISR Operations Spaces are areas that directly support the C5ISR mission. These areas are often contained within a separate secure space from the rest of the facility and may require entry control space and dedicated briefing/planning spaces to support highly classified missions. Although not every C5ISR facility will contain all the areas listed, the criteria are provided as a guide. An Engineering Evaluation should be used to determine the total quantity and type of workstations required and if briefing and/or planning rooms are required. Depending on the nature of the mission, the workstations may be calculated based on the number of systems, networks, or personnel assigned. These spaces are often configured by a Watch Center or Analysis Operations Workspace. See Table 131-3 for further clarification and application of the spaces.

131-9.1 **Watch Center.** The Watch Center generally operates on a shift system where personnel oversee multiple systems using multiple shifts to provide coverage up to 24 hours a day. This space may contain the following areas: Watch Floor (containing Kiosk Workstations, Watch Stander Workstations, and Watch Workstations), Command Viewing Area, and Briefing Rooms.

All allowances for Watch Floor components include circulation area to support unclassified and classified printers, shredders, display walls, and line of site area requirements (Watch Commander Workstations to the Watch Stander Workstations).

131-9.1.1 **Kiosk Workstations.** Kiosk Workstations are provided for standalone systems. The number of Kiosk Workstations required is based on the purpose and necessity of the workstations. This station is also presumed to be unmanned, but available to all personnel on watch for use as needed.

Planning Factors: Allocate 40 NSF (including circulation area) for each Kiosk Workstation that supports up to 2 networks.

Justification: Kiosk Workstations may be justified when stand-alone or separately monitored systems require separate Kiosk Workstations.

131-9.1.2 **Watch Stander Workstations.** The number of Watch Stander Workstations is based on the number of systems being monitored and the number of watch standers per shift.

Planning Factors: Allocate 60 NSF (including circulation area) for each Watch Stander Workstation that supports up to 4 networks.

Justification: Watch Stander Workstations may be provided for operational missions with watch teams.

131-9.1.3 **Watch Commander Workstation.** In addition to Watch Stander Workstations, there are also Watch Commander Workstations required for each group identified within the Watch Center. The number of Watch Commander Workstations required is based on the structure of the watch team oversight and may include a Watch Commander, Deputy Watch Commander, and under instruction Watch Commander Workstations.

Planning Factors: Allocate 100 NSF (including circulation area) for each Watch Commander Workstations that supports up to 4 networks and 4 peripherals (secure telephones and secure video conferencing systems).

Justification: Watch Commander Workstations may be provided for operations missions with watch teams.

131-9.1.4 **Command Viewing Area.** A viewing area immediately adjacent to the Watch Floor Area may be provided for the Commanding Officer and Chief of Staff, if justified. This area may be separated from the Watch Floor by a glass wall, and may be elevated to provide complete visual oversight of the Watch Floor and its associated status boards.

Planning Factors: Allocate 300 NSF for a Command Viewing Area separate from Watch Commander Workstations. This area is separated and elevated from the Watch Floor but has a direct line of site to the Watch Floor and all displays. This space must be justified based on mission requirement.

Justification: Command Viewing Area is authorized for Emergency Operations Centers (CCN 143 65) and Mission Operation Command and Control Facility (CCN 143 80). It may be provided for other category codes with additional justification to include specific mission requirement.

131-9.1.5 **Watch Center Briefing Room.** A separate briefing area with Video Teleconference (VTC) capability is also be required for planning and briefing purposes to ensure uninterrupted operations on the Watch C. This space is separate from general-purpose conferencing capabilities due to mission requirements that may require long-term utilization of the Briefing Rooms, (e.g exercises and/or crisis action response).

Planning Factors: Allocate 500 NSF for a 25-person Watch Center Briefing Room in support of watch operations. All systems and displays monitored on the Watch Floor should also be available in this space.

Justification: Watch Center Briefing Room is authorized for Emergency Operations Centers (CCN 143 65) and Mission Operation Command and Control Facility (CCN 143 80). It may be provided for other category codes with additional justification to include specific mission requirement.

131-9.2 **Analysis Operations.** Analysis Operations generally require use of multiple network systems including both unclassified and classified networks. All personnel assigned to Analysis Operations functions require a dedicated workspace that provides both privacy for independent work and teaming areas. The workstation sizing includes the workstation area and appropriate circulation areas within the Analysis Operations space to accommodate shredders, safes and a printer for each network.

131-9.2.1 Analysis **Workstations (up to 4 networks).** This workstation provides adequate space to support operations personnel that utilize up to 4 different networked systems. This workstation can accommodate multiple

classified systems that require separation from both unclassified systems and other classified systems.

Planning Factors: Allocate 90 NSF (including circulation area) for each workstation required. These workstations should support up to 4 networks of which 2 or more are classified networks and require a separation of 3 feet from each other and from unclassified networks.

Justification: Analysis Workstations (up to 4 networks) may be provided when the operations mission require staff to access more than 2 networks.

131-9.2.2 Analysis Workstations (greater than 4 networks). This workstation provides adequate space to support operations and personnel that utilize more than 4 different networked systems. This workstation can accommodate multiple classified systems that require separation from both unclassified systems and other classified systems.

Planning Factors: Allocate 130 NSF (including circulation area) for each workstation required. These workstations should support more than 4 networks, of which 2 or more are classified networks and require a separation of 3 feet from each other and from unclassified networks.

Justification: Analysis Workstations (greater than 4 networks) may be provided when operations missions require staff to access more than 4 networks.

131-9.2.3 Analysis Teaming Room. An Analysis Teaming Room provides a crisis response operations area to support operations that may last multiple days and is separate from conference room allocations due to the potential long-term operations and classified requirements that are supported.

Note: This is not a substitute for a department conference room, which is already provided by the command conference room calculation and requires mission specific justification.

Planning Factors: Allocate 150 NSF for a 10 PN Analysis Teaming Room.

Justification: Justification should address some, or all, of the following factors as appropriate:

- Mission or functions performed
- Organization size if more than one Analysis Teaming Room for 10 PN is required
- Other justification

Table 131-3. Analysis and Watch Center Space Types

Workstation Type	NSF	Notes
Watch Center – Kiosk	40	This workstation is composed of a single monitor and keyboard assembly. It is generally used as a hoteling station, which supports non-resident access to systems or provides access to a network not accessible to all staff members. In a Watch Center, this Kiosk is not manned, but is provided for access to systems not available at every Watch Stander's Workstation.
Watch Center – Watch Stander Workstation	60	This workstation is composed of multiple monitors and accesses up to 4 different networks or systems.
Watch Center –Watch Commander Workstation	100	This workstation has access to all networks and systems monitored by the Watch Standers and has access to at least 4 peripherals - such as secure telephones and secure video conferencing systems.
Command Viewing Area	300	The Command Viewing Area is separate from Watch Floor. This space must be justified based on mission requirement.
Watch Center - Briefing Room	500	The Watch Center Briefing Room supports planning and briefing functions and ensures uninterrupted operations on the Watch Floor.
Analysis Workstation (up to 4 networks)	90	Each workstation supports up to 4 networks of which 2 or more are classified networks and require a separation of 3 feet from each other and from unclassified networks.
Analysis Workstation (greater than 4 networks)	130	Each workstation supports greater than 4 networks of which 2 or more are classified networks and require a separation of 3 feet from each other and from unclassified networks.
Analysis Teaming Room	150	This space is separate from Conference Room allocations due to the longer-term operations that are supported. This room may be configured to host crisis response operations that may last multiple days. This space must be justified based on mission requirement. <i>Note: This room is not a substitute for a department conference room which is already provided by the Conference Room calculation.</i>

131-10 **MAINTENANCE SPACE.** Maintenance Spaces that are internal to commands providing communications and electronic equipment maintenance may be provided utilizing an Engineering Evaluation, architectural layout, or the allowances provided in Table 131-4. These areas are considered integral to the mission of the command. Communications equipment maintenance areas that support multiple commands are considered external maintenance activities and should be classified as Category Code 217 10 (Electronics and Communication Maintenance Shop). Appropriate justification should also be provided.

131-10.1. **Maintenance Area Basic Components.** Table 131-4 provides the maximum allowance for basic components found within a Maintenance Space. Quantity and composition of these components vary with mission, logistics support systems, and levels of required security; and will be determined by an on-site Engineering Evaluation.

Table 131-4. Maintenance Area Basic Component Maximum Allowances

Component	Max Allowance
	NSF per Component
Work Desks	60
Small Work Tables	10
Computer Tables	30
Workbenches-Full Access	96
Workbenches-Limited Access	60
Storage Lockers	18
Small Storage Lockers	10
Large Storage Shelves	40
Large Storage Cabinet	30
Parts Lockers	12
File Cabinets	10
Test Equipment Storage Cabinets	50
Test Equipment Carts	15
Bookshelves	10
Equipment Shelves	40
Equipment Staging	TBD ⁽¹⁾
Other (provide Description & Justification)	TBD ⁽²⁾

(1) The Equipment staging allowance is provided for C5ISR missions that fabricate or maintain large C5ISR systems and require storage and staging areas. These areas are primarily associated with NIOC Fleet Electronic Support functions, but may be justified by other missions. An Engineering Evaluation and detailed justification to include the average size and quantity of equipment maintained must be provided.

(2) An "Other" allowance is provided for C5ISR missions that have a unique maintenance or storage requirement. An Engineering Evaluation and detailed justification must be provided.

131-11 **TRAINING SPACE.** Due to the nature of C5ISR functions, specialized Training Spaces are required. These activities support ongoing training for command and fleet personnel on the latest C5ISR systems, networks, or threats. Formal course programs such as those provided through Naval Education and Training Command

(NETC) learning sites should be classified as Category Code 171 10 (Academic Instruction Building) or Category Code 171 20 (Applied Instruction Building), and justified accordingly. General military training is not considered valid justification for training spaces and should not be included in the analysis to provide C5ISR Training Spaces.

131-11.1. **Training Stations.** A maximum of 20 Training Stations is provided in a training room. This training space should support the training of system upgrades, the fielding of new hardware and software, and security classifications of equipment. Training rooms that require more than 20 Training Stations require specific course justification. The exact quantity and size of training areas is determined by an Engineering Evaluation aligned to internal operations requirements. Table 131-5 provides applicable classroom types and appropriate space allocations per student station.

Table 131-5. Classroom Type and Student Station Allowances

Classroom Type	Max Student Stations	Training Station NSF
General (standard chairs and desks)	20	22
Work Desk (with CPU, keyboard, monitor)	20	40
Workbench (larger work space to support maintenance training functions)	20	60

131-12 **EQUIPMENT SPACE.** This area is provided for communications and electronic equipment mounted in racks in support of the function(s) being performed by the organization. An Engineering Evaluation is required to determine the total quantity of equipment racks required to support each network or system.

Note: Allowances identified in the following sections provide guidelines for planning purposes when exact values are not available. In accordance with UFC 3-580-01 2-4.4.3 to support equipment refresh and future growth, rack calculations should provide 25 percent spare capacity in each rack, and one spare rack for every four utilized racks. This will provide a growth multiplier of 1.67 which affords adequate rack space to set up new or updated equipment prior to the decommissioning of older systems and future system growth.

131-12.1. **Data Center.** Computer systems and associated components, such as telecommunications and storage systems are housed in the Data Center. This definition excludes facilities exclusively devoted to communications and network equipment (e.g., telephone exchanges and telecommunications rooms).

Data Centers act as a centralized repository, either physical or virtual, for the storage, management, processing, and dissemination of communications and information systems. Depending on the function of the command, these spaces could be the consolidated communications and information server support for the Navy or Marine Corps activities, or may support high-density legacy computing

systems that are integral to an individual command and cannot be consolidated into remote Data Centers.

131-12.2. Communications Security Material Area. This area supports the management and storage of Communications Security (COMSEC) material such as the Electronic Key Management System (EKMS). This area must be segregated and meet security requirements for the highest level of COMSEC material stored and consists of rack mounted equipment and workstations for personnel. An Engineering Evaluation is required to determine the total quantity of equipment racks and workstations to support a Communications Security Material Area.

131-12.3. Commercial Services Equipment. Also referred to as the Cable Plant Area, this area is a specialized equipment area that provides a demarcation point separating the incoming commercial communications sources from the Data Center area. This area is separated to provide controlled access without encroachment on the mission operations. It requires two-layer access, racks and cabinets with telephone lines and switches. This space is only provided when Commercial Services Equipment areas are provided directly to the facility. An average allowance of 25 percent of the Data Center size is to be used for planning purposes.

131-12.4. Network Distribution Area. This area consists of server racks that provide cabling and switching areas that connect operations spaces to the server area. These areas are most often required for operations that maintain additional networks above and beyond the DON Mission Networks, which include but are not limited to: Next Generation Enterprise Network (NGEN), OCONUS Navy Enterprise Network (ONE-Net), Marine Corps Enterprise Network (MCEN) and Global Network Transport (PSNet); and/or include a large watch or analysis operation area where internal distribution areas may be required to provide adequate network management and flexibility. A maximum of 15 percent of the size of the Data Center should be used for planning purposes.

Planning Factors: Although the quantity and size of Equipment Spaces will vary depending on which specific Category Code is being evaluated, the analysis will conform to the following guidance:

- An Engineering Evaluation of the equipment systems is to be used to determine the total quantity of racks required. These racks are to be positioned on a theoretical 2 ft x 4 ft grid.
- Racks should be set up in rows with an equal number of racks.
- A continuous row, with a maximum of 25 ft in length, is allowed before a safety passage must be included between columns or racks.
- The safety passage shall be a minimum of 5 ft wide and aligned to permit direct paths through the rows of racks.
- Racks should be aligned so the front and rear of the rows face each other to create cold aisles (front) and hot aisles (rear) to maximize cooling efficiency.

- When multiple rows of racks are required, a maximum of 6 ft is to be provided between the faces of parallel rows of racks; a maximum of 5 ft is to be provided between the backs of parallel racks; and a minimum of 5 ft is established between the end of a row and a wall. An engineering evaluation and appropriate justification is required for increased distances.
- When support devices such as electrical panels, transformers; heating, ventilation, and air conditioning (HVAC) equipment; and/or large conduit runs are surface mounted to the inside of the walls of an equipment and communications areas containing racks, the clearance requirements outlined above are to be increased by the depth of the respective support device. See Figure 131-2.
- For less than 120 total racks, the recommended server room requirements are listed in Table 131-6. For a server room with less than 10 racks, multiply the total number of racks by 45 net square feet (NSF) per rack.

Table 131-6. Equipment Room Requirement by Total Racks

Total Racks	Total Equipment Rows	Total Columns of Equipment	Total Equipment Room (NSF)	NSF per rack
0-10	1	1	450	45
11-20	2	1	750	38
21-30	3	1	1020	34
31-40	4	1	1320	33
41-50	5	1	1590	32
51-60	6	1	1890	32
61-80	4	2	2420	30
81-100	5	2	2610	29
101-120	6	2	2915	29
>121	To be Determined by Engineering Analysis			28

- For Data Centers that have more than 120 racks, and in the absence of a specific layout, an overall maximum of 28 NSF per rack may be used which accommodates a maximum rack size of 24 inches wide by 48 inches deep.
- Depending on the type of cooling system and cable distribution system utilized in the Data Center, a false deck (also known as a raised floor) may be required. The depth of false deck shall be determined by the system design.

Figure 131-1. Typical Layout of Equipment Mounted in Racks

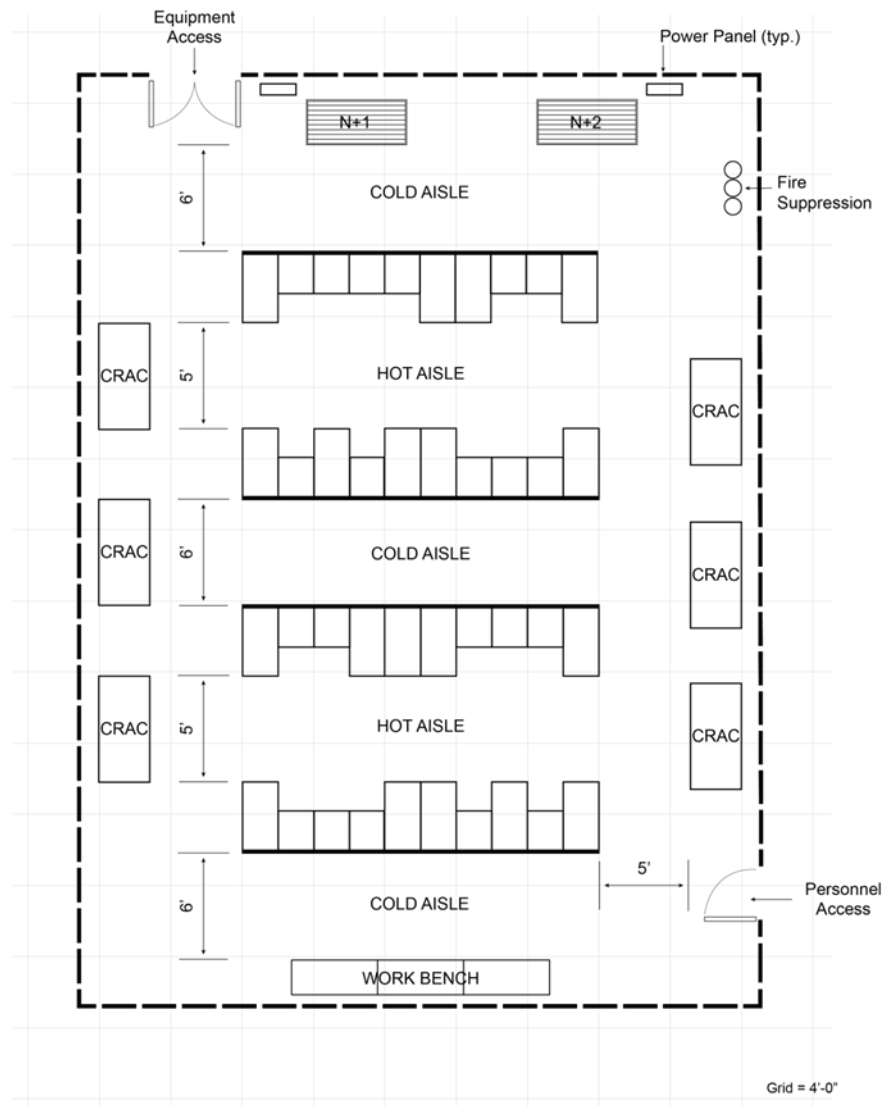

Note: Cooling redundancy within the Data Center is represented as N+1 and N+2; this represents the total number of computer room air conditioner (CRAC) units required, plus one or two extra CRAC units for back up as required. The space requirement for the CRAC units is addressed within the Data Center Mechanical & Electrical Factor found in Section 131-9.

131-12.5. C5ISR Equipment Room Factor. To accommodate the significant electrical and mechanical requirements associated with facilities with large equipment rooms serving as a large Data Center or server space, this factor accounts for the additional spaces required to support the C5ISR equipment rooms that is above and beyond the requirement for the remainder of the facility. The type of mechanical systems used for cooling these types of rooms that support Data Centers and the level of redundancy required, as indicated by the Tier Level assigned to the Data Center, play key roles in the total footprint required. The Tier Level identified for a specific Data Center will dictate the redundancy requirements for each major system and is represented by N+1, N+2, 2N, etc. The general

mechanical and electrical planning factor for Data Centers and server rooms with power densities of 5kW per rack or less, are provided in Table 131-7. Additionally, once the power requirement per Data Center rack exceeds 5 kW per rack, conventional computer room air condition (CRAC) unit based mechanical systems become ineffective to meet the demand of high-density servers. In cases where the power requirement exceeds 5kW per rack or the mission criticality of the facility requires a Tier IV facility, an Engineering Evaluation is required to determine the mechanical, electrical equipment, Uninterruptable Power Source (UPS) system, and emergency generator system requirements for the facility.

Table 131-7. C5ISR Equipment Factor

Tier Level	Data Center Factor
I	1.56
II	2.10
III	2.28

131-13 **IT LOGISTICS SUPPORT SPACE.** A dedicated shipping, receiving, laydown/IT staging, and storage areas may be provided to support the equipment and parts storage for a command. This area is in addition to any maintenance parts and consumables storage area requirements that may also exist.

Planning Factors: IT Logistics Support space may be provided using the following Planning Factors:

- This area should be capable of supporting a refresh rate of 18-24 months plus growth due to new systems. As a general rule, assume that the space can support at least 25 percent of the equipment room racks (volume) and 15 percent of CPUs and Monitors (volume) used within the command.
- The standard stacking height for this type of material is 6 feet. A factor of 0.327 NSF per cubic foot (CF) is applied to the volume of material to determine the required NSF for this functional area.
- To calculate the shipping, receiving, and laydown/IT staging area, multiply the total NSF of storage area by a factor of 2.
- Variance from the standard stacking height or larger storage operations should be classified as Category Code 143 77 (Operational Storage) or Category Code 217 77 (Electronics Spares and Miscellaneous Procured Items and Equipment), and justified accordingly.

131-14 **NET-TO-GROSS.** Unless otherwise noted, a net-to-gross conversion factor of 1.45 is used for all CCNs within the 131 Series. This factor applies to all spaces (including the Data Center) and is required to account for the additional electrical equipment, mechanical equipment, and architectural or structural elements required to directly support the electronic and communications systems and subsystems throughout the facility.

131-15 **ASSOCIATED INFRASTRUCTURE.** Additional power and HVAC system redundancy must be provided for Tier II and Tier III facilities. For Tier II facilities: N+1 generators, N+1 Uninterruptible Power Supply (UPS) system, and N+1 HVAC components must be provided for critical areas. For Tier III facilities: N+1 generators, 2N Uninterruptible Power Supply (UPS) systems, 2N HVAC, multiple distribution paths for critical power, multiple distribution paths for cooling, and elimination of single points of failure must be provide for critical areas. Fast action fire suppression systems that do not damage equipment are also required for critical areas in Tier III facilities.

131-16 **REQUIREMENTS SUMMARY.** The functional areas authorized by right (A), authorized with justification (J), or not authorized (N) for each the following Category Codes 131 15, 131 24, 131 35, 131 40, 131 50, 143 65, and 143 80 are shown in Table 131-8.

Table 131-8 Functional Areas Summary Matrix for Communications Buildings

Functional Area	Subspace	131 15	131 24	131 35	131 40	131 50	143 65	143 80
Administrative General Purpose	Private Office	A	A	A	J	A	J	A
	Open Office (Cubicle)	A	A	A	J	A	A	A
Special Purpose Space Basic	Admin Support	A	A	A	J	A	A	A
	Break Room	A	A	J	J	J	A	A
	Break Room Kitchen	J	J	J	N	J	N	J
	Classified Vault	J	J	J	J	J	J	J
	Conference Rooms/VTC	A	A	J	J	J	A	A
	Duty/Bunk Room	J	J	J	J	J	J	J
	Mail Room	J	J	J	J	J	N	J
	Technical Publications Area	J	J	J	J	J	J	J
Special Purpose Space Fitness/Locker/ Shower	Fitness Room ¹	J	J	J	N	J	N	J
	Locker Room	J	J	J	N	J	J	J
	Shower Room	J	J	J	N	J	J	J
Special Purpose Space Security	Quarterdeck/Entry Control	A	A	J	J	J	J	A
	Special Security Office	J	J	J	J	J	J	J
Operations Space	Watch Center	A	A	A	J	A	A	A
	Analysis Operations	A	A	J	J	J	A	A
Maintenance Space	Maintenance	J	J	J	J	J	N	J
Training Space	Training	J	J	J	N	J	N	J
IT Logistics Support Space	IT Logistics Support Space	A	A	J	J	J	N	A
Equipment Space	Data Center/Server	A	A	N	N	N	A	A
	Commercial Services Equipment	A	A	N	N	N	N	J
	Communications Security Material Area	A	A	N	N	N	J	J
	Network Distribution Area	A	A	N	N	N	N	J
	Specialized Equipment	J	J	A	A	A	N	J

Legend:

A – Approved without additional justification (based on the staffing and mission requirements)

J – Only approved with specific justification of mission requirements

N – Not approved for this category code

(1). This requirement should be captured under CCN 740 45. Fitness Rooms are only allowed in accordance with CNICINST 1710.1 where by the command is located more than a 15- minute commute by vehicle from the nearest Morale Welfare and Recreation (MWR) Fitness Center, or in cases where service members are required to be on station and unable to leave for 18 hours at any given time. The fitness room must also have approval from the Installation Commanding Officer.

131 10 CABLE HOUSE (SF)**FAC: 1311****BFR Required: Y**

13110-1 **DEFINITION.** A Cable House is an unmanned facility that functions either as an external junction point for coaxial cables, or as mechanical space for support equipment associated with Extremely Low Frequency (ELF) and Very Low Frequency (VLF) antennas. As a junction point for coaxial cables, it permits significant changes of cable direction without exceeding the bending radius limit specified by the cable manufacturer, and provides a physical access point for installation and maintenance of the cables that connect equipment areas and their respective antenna systems. The Cable House will be located within, or adjacent to, the antenna field containing ELF, VLF, Low Frequency (LF), and/or High Frequency (HF) antennas for shore to ship, and/or shore-to-shore communications.

13110-2 **FREQUENCIES.** For Very High Frequency (VHF) and/or Ultra High Frequency (UHF) systems in support of aircraft operations and tactical base support systems, a Cable House functions as a collection point that permits communication cables from multiple locations to be combined into a single path or trench that serves an single operational facility such as a Control Tower or Emergency Control Center.

13110-3 **ALLOWANCE.** Although no requirement calculations are associated with this category code, and requirements are based on an as needed basis, the maximum size of a Cable House should not exceed 27.87 GSM (300 NSF).

131 12 COMMUNICATIONS MAINTENANCE VAULT (EA)**FAC: 8927****BFR Required: N**

13112-1 **DEFINITION.** A communications maintenance vault is a handhole, manhole, or confined space used for non-electrical splice and transport.

131 13 COMMUNICATIONS MAINTENANCE TUNNEL (LF)**FAC: 8931****BFR Required: N**

13113-1 **DEFINITION.** This type of tunnel is an underground communications maintenance walkway accessible by personnel for communication line inspections, upgrades, and repairs below ground.

131 15 COMMUNICATIONS, INFORMATION, OR INTELLIGENCE FACILITY (SF)**FAC: 1311****BFR Required: Y**

13115-1 **DEFINITION.** Communications, Information, or Intelligence Facilities are responsible for information processing, delivery of information services, and information/data storage. These facilities ultimately support the Joint Information Environment (JIE). The JIE/ identifies several different types of functional nodes: computing nodes (e.g. Data Centers), communication nodes (e.g. Network Gateways), and operations nodes (e.g. Enterprise Operation Centers). These nodes should be viewed as functional enclaves, not separate facilities; in fact, multiple nodes and node types may be present in a single physical facility. For further understanding of the different functional nodes refer to *DoD Information Enterprise Architecture, Data Center Reference Architecture Version 1.10 Final April 25, 2014 Table 1 and Table 2.*

13115-2 **FUNCTION TYPES.** Table 13115-1 provides a list of typical functions and sample commands that apply to this category code.

Table 13115-1. Function Types and Sample Organizations

Function Type	Sample Organizations
Data Center or Server Center (Only)	Any
Communications Center	Naval Computer and Telecommunications Station (NCTS), Naval Computer and Telecommunications Master Area Station (NCTAMS), etc.
Weather Center	Fleet Weather Centers (FWC), Joint Typhoon Warning Center (JTWC), etc.
Information and Intelligence Commands	NIOC, Navy Information Operations Division (NIOD), Navy Cyber Defense Operations Command (NCDOC), Navy Information Warfighting Development Center (NIWDC), Naval Network Warfare Command (NNWC), etc.

13115-2 **FUNCTION AREAS.** A Communications, Information, or Intelligence Facility may contain the functional areas shown in Table 13115-2. This facility will be supported by an Uninterruptible Power Supply (UPS) system and emergency generator system. Please refer to the guidelines provided in the introduction of 131-series Category Codes for C5ISR buildings to calculate the requirement for each functional area. Per section 131-14, the authorized **net-to-gross** factor is 1.45.

**Table 13115-2. Communications, Information, or Intelligence Facility
Functional Areas**

Functional Area	Subspace	131 15
Administrative General Purpose	Private Office	A
	Open Office (Cubicle)	A
Special Purpose Space Basic	Admin Support	A
	Break Room	A
	Break Room Kitchen	J
	Classified Vault	J
	Conference Rooms/VTC	A
	Duty/Bunk Room	J
	Mail Room	J
	Technical Publications Area	J
Special Purpose Space Fitness/Locker/ Shower	Fitness Room ¹	J
	Locker Room	J
	Shower Room	J
Special Purpose Space Security	Quarterdeck/Entry Control	A
	Special Security Office	J
Operations Space	Watch Center	A
	Analysis Operations	A
Maintenance Space	Maintenance	J
Training Space	Training	J
IT Logistics Support Space	IT Logistics Support Space	A
Equipment Space	Data Center/Server	A
	Commercial Services Equipment	A
	Communications Security Material Area	A
	Network Distribution Area	A
	Specialized Equipment	J

Legend:

A – Approved without additional justification (based on the staffing and mission requirements)

J – Only approved with specific justification of mission requirements

(1). This requirement should be captured under CCN 740 45. Fitness Rooms are only allowed in accordance with CNICINST 1710.1 where by the command is located more than a 15- minute commute by vehicle from the nearest Morale Welfare and Recreation (MWR) Fitness Center, or in cases where service members are required to be on station and unable to leave for 18 hours at any given time. The fitness room must also have approval from the Installation Commanding Officer.

13115-4 **SPACE DISTRIBUTION.** A Communications, Information, or Intelligence Facility will generally consist of the functional space types shown in Table 13115-3: General Administrative and Special Purpose Space, C5ISR Operations (watch/analysis) Space, Maintenance Space, Training Space, Equipment Space (racked equipment area, often called a Data Center or server area), and IT Logistics Space. The

percentages shown in Table 13115-3 provide a guide of the general size of these areas in relation to the overall facility. For instance, a stand-alone Data Center would likely be made up of 75 percent Equipment Space; 20 percent of General Administrative and Special Purpose Space, C5ISR Operations Space, Maintenance Space, and Training Space; and 5 percent IT Logistics Space.

Table 13115-3 Function Type and Space Type Distribution

Function Type	General Admin & Special Purpose	C5ISR Operations	Maintenance	Training	Equipment	IT Logistics
Data Center/Server Space (Only)	20%				75%	5%
Communications Center	25%	15%	5%	5%	45%	5%
Weather Center	34%	40%	n/a	1%	20%	5%
Information Analysis Center	30%	35%	n/a	5%	20%	5%

13115-4 **BUILDING BLOCKS.** Figure 13115-1 provides a diagram demonstrating a summary of the applicable spaces, appropriate allocation factors, and the special relationship for Communications, Information, and/or Intelligence Facilities.

Figure 13115-1. Communications, Information, or Intelligence Facility Building Blocks Diagram

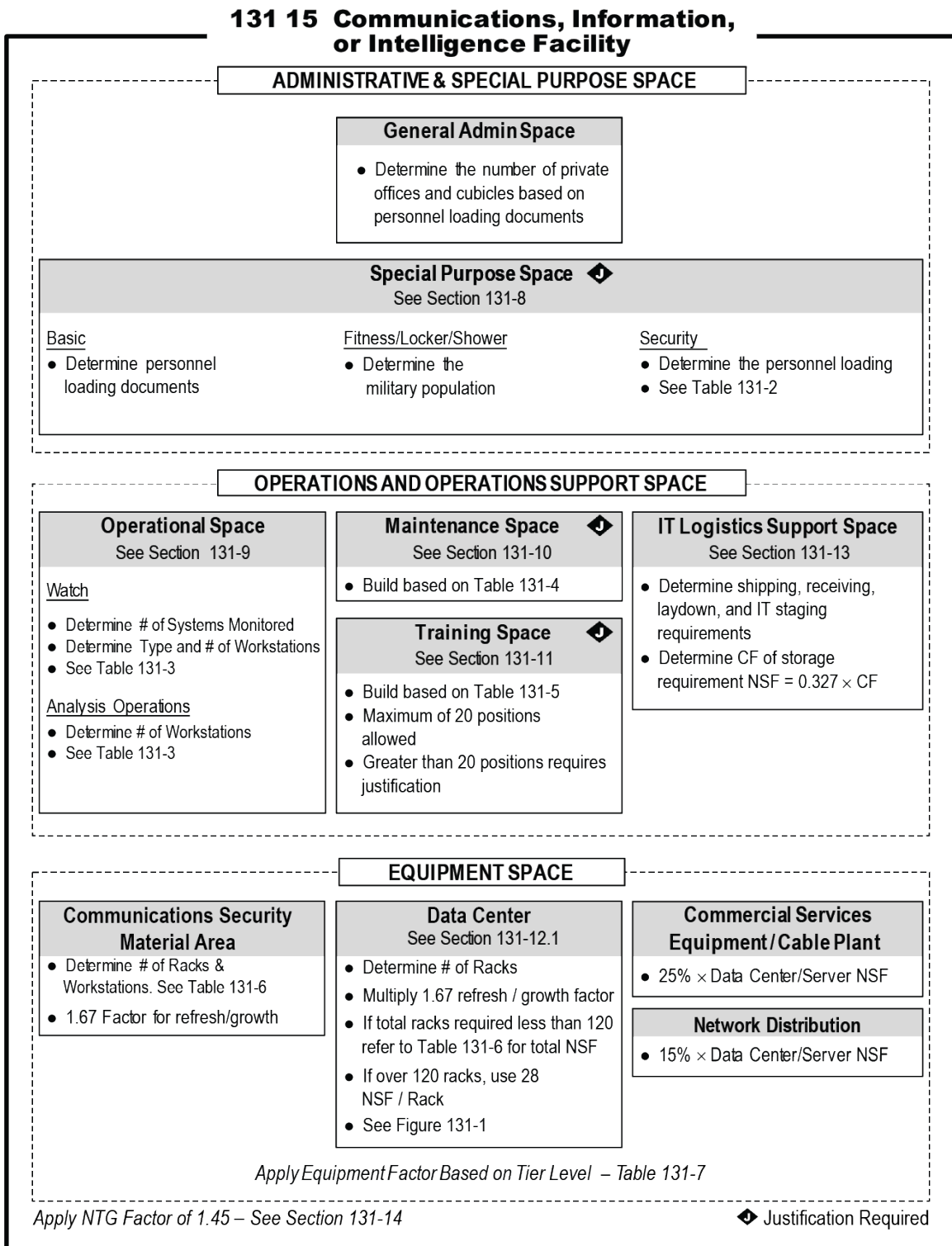

131 17 COMMUNICATIONS MAINTENANCE CHANNEL (LF)**FAC: 8932****BFR Required: N**

13117-1 **DEFINITION.** This type of facility is an underground communications maintenance channel accessible via ground level access panels to allow inspections, upgrades, and repairs to communication lines below ground.

131 20 COMMUNICATIONS RELAY FACILITY (SF)**FAC: 1311****BFR Required: Y**

13120-1 **DEFINITION.** A Communications Relay Facility is an unmanned facility or enclosure associated with the operation of Microwave (MW) communications systems. It contains rack mounted communications receiving, amplification, and transmitting equipment, along with an Uninterruptible Power Source (UPS) system and an emergency generator system. A Communications Relay Facility can be a permanent facility, but unless location and atmospheric conditions dictate otherwise, it is normally Class III Property. It is located at the base of the antenna tower that contains the associated microwave dishes. The size of the facility or enclosure is dependent on the number of microwave links be served by the antenna tower and by the quantity of commercial equipment (cell phone) systems that DON has authorized. See Table 13120-1.

Table 13120-1 Allowances

Facility Size	Description	Allowance
Small Facility	Two Microwave Links with no commercial tenants	16 GSM (172 GSF)
Medium Facility	Three or more Microwave Links with no commercial tenants	20 GSM (215 GSF)
Large Facility	Three or more Microwave Links with multiple commercial tenants	22 GSM (237 GSF)

131 22 VHF/UHF COMMUNICATIONS FACILITY (SF)**FAC: 1311****BFR Required: Y**

13122-1 **DEFINITION.** A VHF/UHF Communications Facility can either be contained within a permanent facility or within Class III Property. It contains a limited amount of rack mounted communications receiving, amplification, and transmitting equipment associated with Airfield Operations, Security and Fire Operations, or a tactical Communications system integral to unique special operations. A small

Uninterruptible Power Source (UPS) system and an emergency generator system support a VHF/UHF Communications Facility.

13122-2 **Allowance.** Although no requirement calculations are associated with this Category Code, and requirements are based on an as needed basis, the maximum size of a VHF/UHF Communications Facility should not exceed 41.81 GSM (450 NSF).

131 24 SATELLITE COMMUNICATIONS FACILITY (SF)

FAC: 1312

BFR Required: Y

13124-1 **DEFINITION.** Satellite Communications Facility is often referred to as a 'gateway facility' supporting Worldwide, Regional, and Area of Responsibility (AOR) communications. It contains office and support requirements, equipment and operations areas, maintenance and training areas, and limited storage areas for ready-to-issue communications systems and subsystems required for the reception, processing, routing, and dissemination of incoming and outgoing communications traffic.

13124-2 **ANTENNAS.** The receiving/transmitting antennas systems associated with this facility are directional in nature. Antennas that are in excess of 3 meters in diameter are mounted, in most cases, on a dedicated tower or support structure that is integral to the antenna. In selected instances, the functional equipment associated with a Satellite Communications Facility may be located within a Communications, Information, Or Intelligence Facility (131 15), and thus this Category Code should be used only where 'stand-alone' facilities are being evaluated.

13124-2 **FUNCTIONAL AREAS.** A Satellite Communications Facility may contain the functional areas shown in Table 13124-1. This facility will be supported by an Uninterruptible Power Support (UPS) system and emergency generator system. Please refer to the guidelines provided in the introduction of 131-series Category Codes for C5ISR buildings to calculate the requirement for each functional area. Per section 131-14, the authorized **net-to-gross** factor is 1.45.

13124-3 **BUILDING BLOCKS.** Figure 13124-1 provides a diagram demonstrating a summary of the applicable spaces, appropriate allocation factors, and the special relationship for Satellite Communications Facilities.

Table 13124-1. Satellite Communications Facility Functional Areas

Functional Area	Subspace	131 24
Administrative General Purpose	Private Office	A
	Open Office (Cubicle)	A
Special Purpose Space Basic	Admin Support	A
	Break Room	A
	Break Room Kitchen	J
	Classified Vault	J
	Conference Rooms/VTC	A
	Duty/Bunk Room	J
	Mail Room	J
	Technical Publications Area	J
Special Purpose Space Fitness/Locker/ Shower	Fitness Room ¹	J
	Locker Room	J
	Shower Room	J
Special Purpose Space Security	Quarterdeck/Entry Control	A
	Special Security Office	J
Operations Space	Watch Center	A
	Analysis Operations	A
Maintenance Space	Maintenance	J
Training Space	Training	J
IT Logistics Support Space	IT Logistics Support Space	A
Equipment Space	Data Center/Server	A
	Commercial Services Equipment	A
	Communications Security Material Area	A
	Network Distribution Area	A
	Specialized Equipment	J

Legend:

A – Approved without additional justification (based on the staffing and mission requirements)

J – Only approved with specific justification of mission requirements

(1). This requirement should be captured under CCN 740 45. Fitness Rooms are only allowed in accordance with CNICINST 1710.1 where by the command is located more than a 15- minute commute by vehicle from the nearest Morale Welfare and Recreation (MWR) Fitness Center, or in cases where service members are required to be on station and unable to leave for 18 hours at any given time. The fitness room must also have approval from the Installation Commanding Officer.

Figure 13124-1. Satellite Communications Facility Building Blocks Diagram

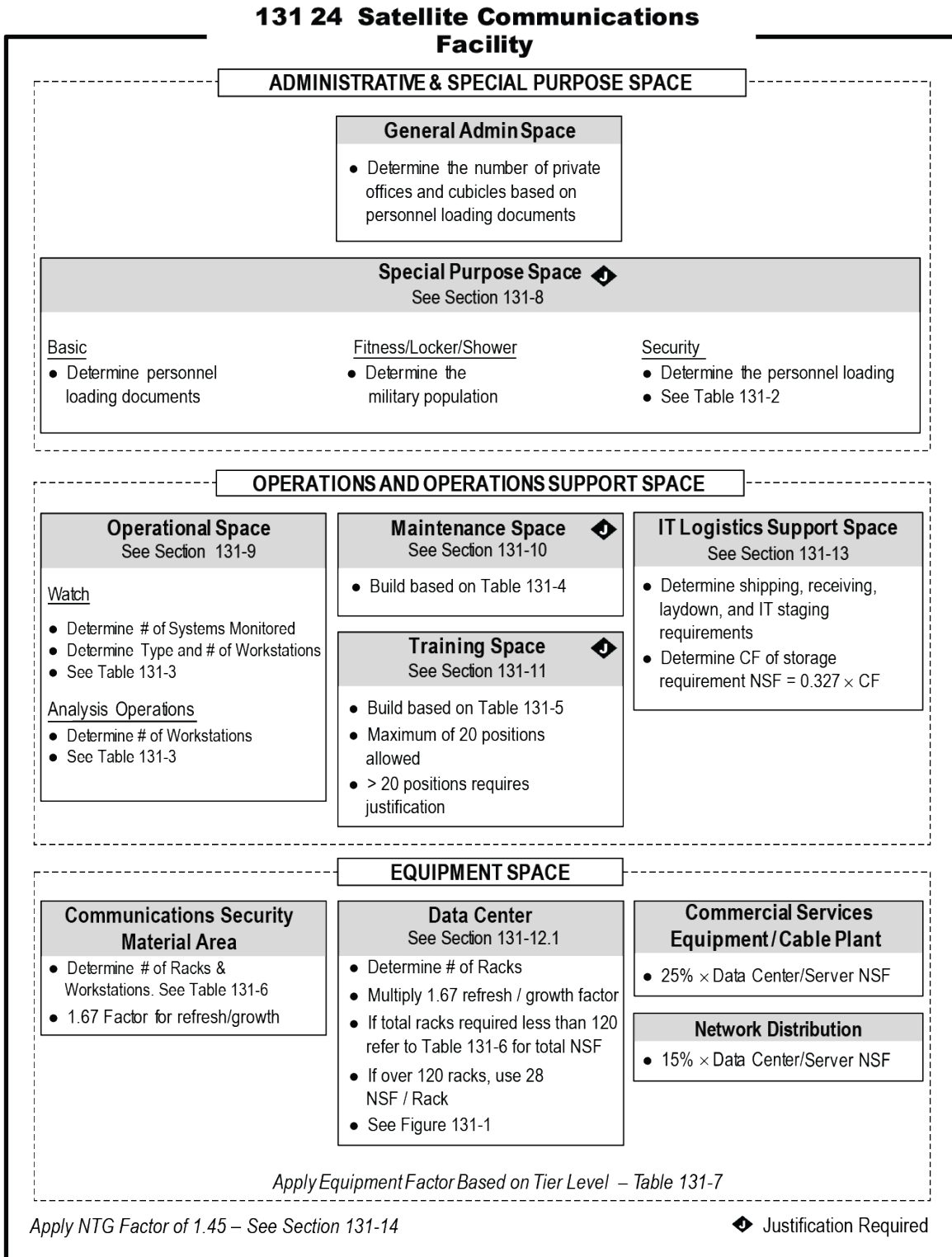

131 25 TELEMETRY BUILDING (SF)**FAC: 1311****BFR Required: Y**

13125-1 **DEFINITION.** A Telemetry Building is an extremely specialized and unique facility specifically designed for the tracking of missiles and satellites. It can be a permanent facility, or configured as a mobile asset within Class III property. As a permanent facility, it will contain equipment areas for transmitters, receivers, and recorders and personnel areas for operators and staff support elements. The size of equipment areas will be dependent upon the quantity of mission specific arrays of tracking antennas and communications interfaces. Personnel, support, maintenance, and logistics support requirements will be dependent on the infrastructure of the Shore Activity with which the Telemetry Building is collocated and will require an Engineering Analysis. If configured within Class III property, a maximum of three fifty-foot by twelve-foot vans are standard for the support of equipment, operations, and logistics spaces.

131 30 HELIX HOUSE (SF)**FAC: 1311****BFR Required: Y**

13130-1 **DEFINITION.** A Helix House contains a Helical Coil and associated antenna tuning devices directly associated with, and integral to, the transmission of Low Frequency (LF), Very Low Frequency (VLF), and Extremely Low Frequency (ELF) communications.

13130-2 It is an unmanned facility, and is located within an antenna field associated with a Transmitter Building (Category Code 131 50). It is connected to a Transmitter Building by a cable trench, which contains power and signal cables. The Helix house is positioned adjacent to its respective antenna system.

13130-3 The size of a Helix House is totally dependent on the output power and operating frequency of the LF, VLF, or ELF transmitter located within the Transmitter Building. Although some AN/FRT-72 LF transmitters remain in the DON inventory, the AN/FRT-95 is the current generation of LF transmitters. An allowance of 342nsm (3,681nsf) is provided for a Helix House in support of the AN/FRT-95. VLF and ELF transmitters, which operate in the less than 30Kc range, are special manufacture units. Mission and location of the Transmitter Building, and coverage within a specific Area of Operation determine frequency and power. An allowance of 439nsm (4,725nsf) is normally provided for a Helix House in support of VLF and ELF transmitters.

131 35 RECEIVER BUILDING (SF)**FAC: 1311****BFR Required: Y**

13135-1 **DEFINITION.** A Receiver Building supports a 24-hour a day, 7-day a week operations requirement for shore to shore and ship to shore administrative, tactical, and

strategic High Frequency (HF) communications. This building may also be used to support transceivers, which are capable of both receiving and transmitting. *Note: if the transmitting only equipment is required, please refer to category code 131 50 Transmitter Building.*

The Receiver Building contains an equipment area with racked receivers and interface equipment, a maintenance area, and a storage area containing a small quantity of spare parts. A small personnel support space containing a toilet facility and break area is considered part of the facility. An Uninterruptible Power Source (UPS) system and an emergency generator system support a Receiver Building.

13135-2 **LOCATION.** The Receiver Building is physically located near the center of the receive antenna field, and it is connected to all antennas via direct buried coaxial cables. Location requirements for a Receiver Building and its associated antenna field with respect to possible areas of interference are provided in Table 13135-1 below.

Table 13135-1. Communications Distance Separations

From any High Frequency Antenna at a Receiver Site to:	
Navy Very Low Frequency (VLF) Transmitter Buildings	25 miles
Navy Low Frequency and High Frequency Transmitter Buildings	15 miles
Transmitting Facilities Not Under Navy Control	5 miles
Runways and Guide Paths Aeronautical Receivers	1,500 feet
General Communications Receivers	5 miles
Main Highways (hourly traffic count over 1,200 vehicles)	3,000 feet
Overhead High Tension Power Lines to include Receiver Station Feeders less than 100KV	1,000 feet
Overhead High Tension Power Lines to include Receiver Station Feeders over 100KV	2 miles
Residential Areas Not Under Navy Control	1 mile
Light Industry	3 miles
Heavy Industry	5 miles
Primary Power Plants	5 miles

13135-3 **FUNCTIONAL AREAS.** A Receiver Building may contain the functional areas shown in Table 13135-2. In instances where the Receiver Building is located in an isolated location, and thus not readily supported by the staff of the associated Communications, Information, or Intelligence Facility (131 15), additional personnel

support functions may be justified with appropriate documentation. These areas may include Conference Room, Break Room Kitchen, Locker Rooms, Shower Rooms, Duty/Bunk Rooms etc. This facility may also be supported by an Uninterruptible Power Support (UPS) system and emergency generator system. Please refer to the guidelines provided in the introduction of 131-series Category Codes for C5ISR buildings to calculate the requirement for each functional area. Per section 131-14, the authorized **net-to-gross** factor is 1.45.

See Table 13135-2 for additional spaces allowed with justification. In some instances, functions performed by a Receiver Building are an integral part of a Communications, Information, or Intelligence Facility (131-15), thus this Category Code should be used only where 'stand-alone' facilities are being evaluated.

Table 13135-2. Receiver Building Functional Areas

Functional Area	Subspace	131 35
Administrative General Purpose	Private Office	A
	Open Office (Cubicle)	A
Special Purpose Space Basic	Admin Support	A
	Break Room	A
	Break Room Kitchen	J
	Conference Rooms/VTC	J
	Duty/Bunk Room	J
Special Purpose Space Fitness/Locker/ Shower	Fitness Room ¹	J
	Locker Room	J
	Shower Room	J
Special Purpose Space Security	Quarterdeck/Entry Control	J
Operations Space	Watch Center	J
	Analysis Operations	J
Maintenance Space	Maintenance	A
Training Space	Training	J
IT Logistics Support Space	IT Logistics Support Space	A
Equipment Space	Data Center/Server	A
	Specialized Equipment	A

Legend:

A – Approved without additional justification (based on the staffing and mission requirements)

J – Only approved with specific justification of mission requirements

(1). This requirement should be captured under CCN 740 45. Fitness Rooms are only allowed in accordance with CNICINST 1710.1 where by the command is located more than a 15- minute commute by vehicle from the nearest Morale Welfare and Recreation (MWR) Fitness Center, or in cases where service members are required to be on station and unable to leave for 18 hours at any given time. The fitness room must also have approval from the Installation Commanding Officer.

13135-4 **BUILDING BLOCKS.** Figure 13135-1 provides a diagram demonstrating a summary of the applicable spaces, appropriate allocation factors, and the special relationship for Receiver Buildings.

Figure 13135-1. Receiver Building Building Blocks Diagram

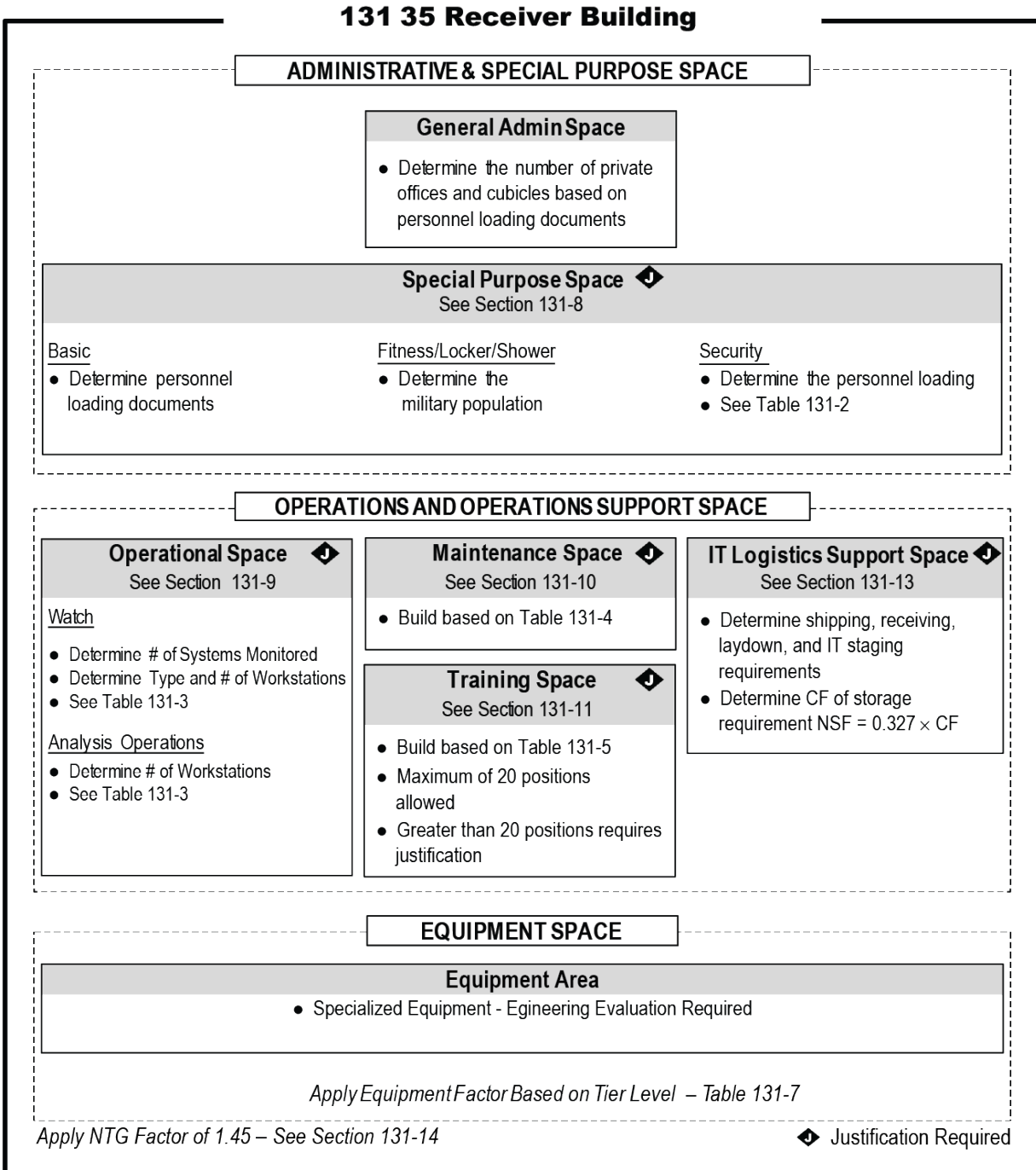

131 40 TELECOMMUNICATIONS DISTRIBUTION FACILITY (SF)**FAC: 1311****BFR Required: Y**

13140-1 **DEFINITION.** A Telecommunications Distribution Facility is a dedicated facility that supports the distribution of telecommunications systems across Navy Installations and Regions. This facility is often unmanned or has limited space for support staff. This type of facility contains the telecommunications switches and distribution frames. It may also contain the incoming demarcation point for commercial services or support the outside cable plant services for an installation or a special area. The facility is supported by Uninterruptible Power Source (UPS) systems and emergency generator systems, and may use a combination of hard wire, microwave, and satellite system to interface with the commercial providers. The receiving/transmitting antennas are normally commercial units and are directional in nature. The antennas are mounted on a dedicated tower or support structure immediately adjacent to the equipment they support. In many instances the telecommunications systems and their respective antennas are an integral part of a Communications, Information, or Intelligence Facility (Category Code 131 15). This Category Code (131 40) should only be used where 'stand-alone' facilities are being evaluated.

13140-2 **FUNCTIONAL AREAS.** A Telecommunications Distribution Facility may contain the functional areas shown in Table 13140-1. This facility may be supported by an Uninterruptible Power Supply (UPS) system and emergency generator system. Please refer to the guidelines provided in the introduction of 131-series Category Codes for C5ISR buildings to calculate the requirement for each functional area. Per section 131-14, the authorized **net-to-gross** factor is 1.45.

13140-3 **BUILDING BLOCKS.** Figure 13140-1 provides a diagram demonstrating a summary of the applicable spaces, appropriate allocation factors, and the special relationships for Telecommunications Distribution Facility.

Table 13140-1. Telecommunications Distribution Facility Functional Areas

Functional Area	Subspace	131 40
Administrative General Purpose	Private Office	J
	Open Office (Cubicle)	J
Special Purpose Space Basic	Admin Support	J
	Break Room	J
	Classified Vault	J
	Conference Rooms/VTC	J
	Duty/Bunk Room	J
	Mail Room	J
	Technical Publications Area	J
Special Purpose Space Security	Quarterdeck/Entry Control	J
	Special Security Office	J
Operations Space	Watch Center	J
	Analysis Operations	J
IT Logistics Support Space	IT Logistics Support Space	J
Equipment Space	Specialized Equipment	A

*Legend:**A – Approved without additional justification (based on the staffing and mission requirements)**J – Only approved with specific justification of mission requirements*

Figure 13140-1. Telecommunications Distribution Facility Building Blocks Diagram

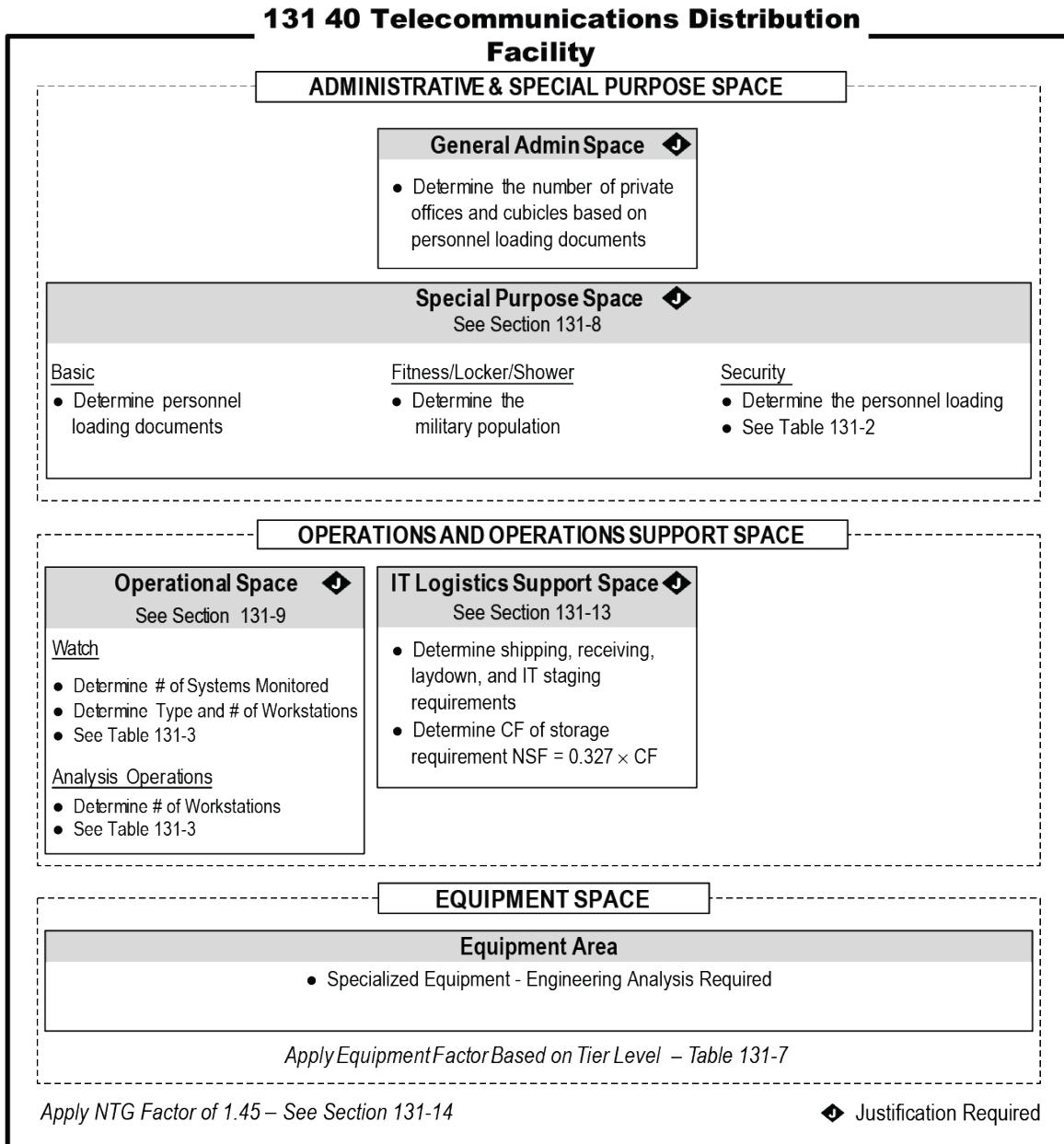

131 42 AUTOMATIC COMMUNICATIONS SWITCHING CENTER (SF)**FAC: 1311****BFR Required: Y**

13142-1 An Automatic-Communications Switching Center identifies a facility that contains the Telephone Switch and its immediate support infrastructure. Although it is possible that some isolated examples of this configuration may still exist, the current communications architecture for this equipment places it within a Telecommunications Distribution Facility (Category Code 131 40).

Use for Inventory Purposes only.

131 45 TERMINAL EQUIPMENT BUILDING (SF)**FAC: 1311****BFR Required: Y**

13145-1 This facility originally, and currently to a minor extent, performs as a single-function building that is in direct support of High Frequency (HF) or Low Frequency (LF) communications. It provides an intermediate connection point that is required technically to support communications configuration, or is required as the result of waveguide or cable loss.

13145-2 A Terminal Equipment Building is also the designation currently given to a new generation of facilities associated with satellite equipment and the selected equipment in support of the satellite antenna. It is commonly referred to as an equipment shelter and can be located within the pedestal base of the antenna or in a separate enclosure immediately adjacent to the base of the antenna. This new generation facility is Class III property in most instances. Although the antenna is classified as a structure, this Category Code is appropriate for 'stand-alone' configurations.

131 50 TRANSMITTER BUILDING (SF)**FAC: 1311****BFR Required: Y**

13150-1 **DEFINITION.** A Transmitter Building supports a 24 hour a day, 7 day a week operations requirement for shore to shore, and shore to ship administrative, tactical, and strategic High Frequency (HF), Low Frequency (LF), and Very Low Frequency (VLF) communications. It contains an equipment area with stand-alone and racked transmitters, as well as their associated interface equipment, a maintenance area, and a storage area containing a small quantity of spare parts. A small personnel support space containing a toilet facility and break area is considered part of the facility. The Transmitter Building is physically located near the center of the transmit antenna field, and is connected to all antennas via direct buried coaxial cables for HF applications, or by a dedicated power and signal trench for LF and VLF applications. Due to the variable nature of transmitter equipment, an Engineering Evaluation is required to calculate the equipment and operations space requirements.

13150-2 **DISTANCE SEPARATIONS.** A specific Transmitter Building will support one of the following: HF only, HF and LF, VLF only, or ELF only operations. Location requirements for a Transmitter Building and its associated antenna field, with respect to possible areas of interference, are provided in Table 13150-1 below. An Uninterruptible Power Source (UPS) system and an emergency generator system support a Transmitter Building.

Table 13150-1. Communications Distance Separations

From the Nearest High Frequency, HF/LF/VLF/ELF Antenna Supporting a Transmitter Site to:	
Transmitting Facilities Not Under Navy Control	5 miles
Runways and Guide Paths Aeronautical Transmitters	1,500 feet
Main Highways (hourly traffic count over 1,200 vehicles)	1,000 feet
Overhead High Tension Power Lines to include transmitter station feeders	1,000 feet

13150-3 **FUNCTIONAL AREAS.** A Transmitter Building may contain the functional areas shown in Table 13150-2. This facility may be supported by an Uninterruptible Power Supply (UPS) system and emergency generator system. To calculate the area required to support the specialized equipment associated with each type of transmitter, an Engineering Evaluation is required. Specific requirements may be classified; therefore proper security clearance is required to obtain the information.

Please refer to the guidelines provided in the introduction of 131-series Category Codes for C5ISR buildings for additional information to calculate the requirement for other standard functional areas. Per section 131-14, the authorized **net-to-gross** factor is 1.45.

Table 13150-2. Transmitter Building Functional Areas

Functional Area	Subspace	131 50
Administrative General Purpose	Private Office	A
	Open Office (Cubicle)	A
Special Purpose Space Basic	Admin Support	A
	Break Room	J
	Break Room Kitchen	J
	Classified Vault	J
	Conference Rooms/VTC	J
	Duty/Bunk Room	J
	Mail Room	J
	Technical Publications Area	J
Special Purpose Space Fitness/Locker/Shower	Fitness Room ¹	J
	Locker Room	J
	Shower Room	J
Special Purpose Space Security	Quarterdeck/Entry Control	J
	Special Security Office	J
Operations	Watch Center	A
	Analysis Operations	J
Maintenance	Maintenance	J
Training	Training	J
IT Logistics Support Space	IT Logistics Support Space	J
Equipment	Specialized Equipment	A

Legend:

A – Approved without additional justification (based on the staffing and mission requirements)

J – Only approved with specific justification of mission requirements

(1). This requirement should be captured under CCN 740 45. Fitness Rooms are only allowed in accordance with CNICINST 1710.1 where by the command is located more than a 15- minute commute by vehicle from the nearest Morale Welfare and Recreation (MWR) Fitness Center, or in cases where service members are required to be on station and unable to leave for 18 hours at any given time. The fitness room must also have approval from the Installation Commanding Officer.

**Figure 13150-1. Transmitter Building
Building Blocks Diagram**

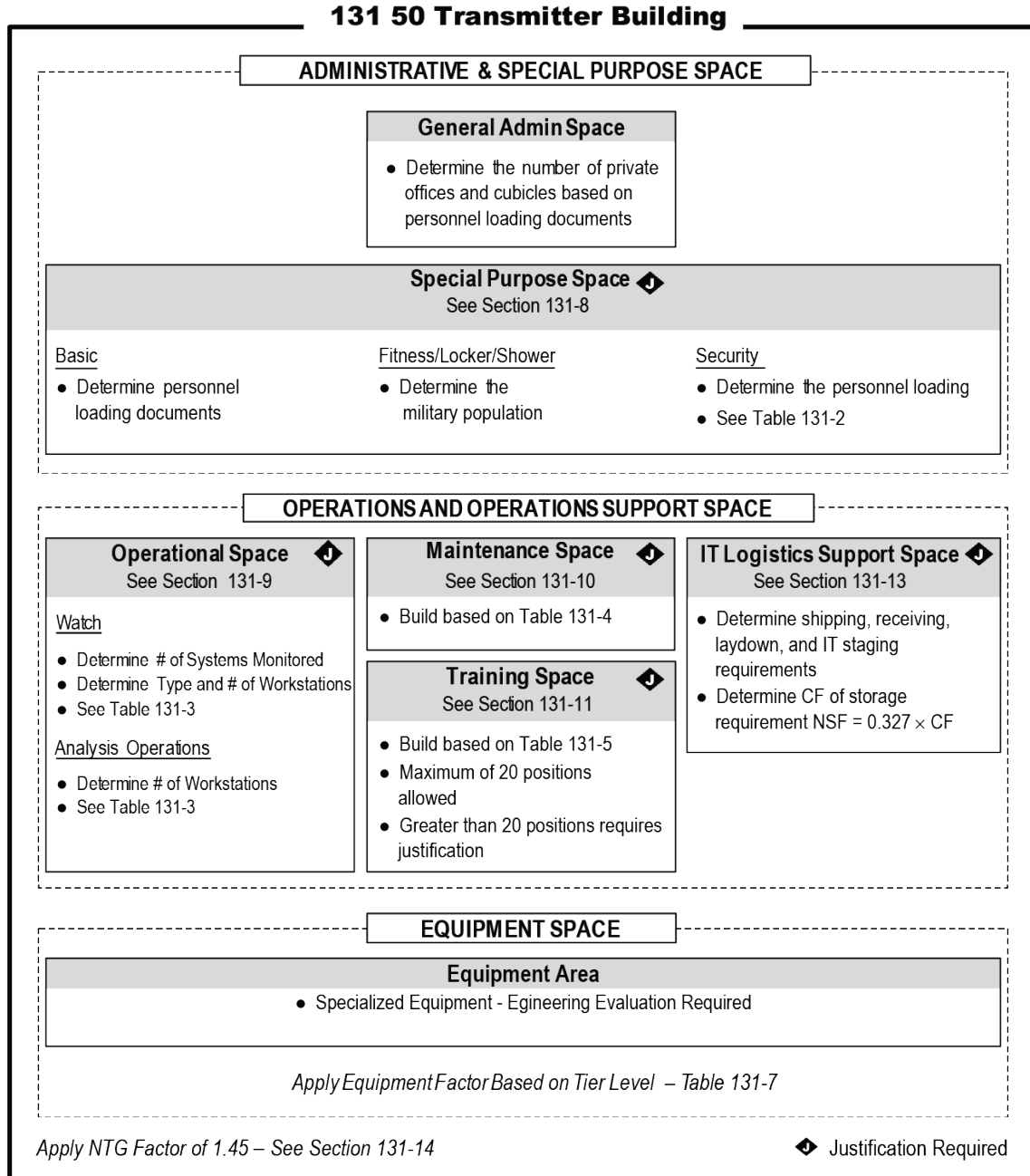

131 55 CIRCULARLY DISPOSED ANTENNA ARRAY BUILDING (SF)**FAC: 1311****BFR Required: N**

13155-1 **DEFINITION.** A Circularly Disposed Antenna Array (CDAA) Building is a High Frequency Direction Finding (HFDF) facility that contains the tuning and receiving equipment associated with the AN/FRD-10 antenna. Category Code 131 55 is specific to Naval Security Group Activity (NSGA) locations. It is a technical and operational requirement that the CDAA building be located within the center of the AN/FRD-10 array. The AN/FRD-10, commonly referred to as a Wullenweber antenna, requires specific siting criteria as outlined in NSGINST 2450.1. The CDAA building also contains staff and personnel support spaces, maintenance and training spaces, and storage spaces.

13155-2 The Department of Navy no longer maintains a HFDF mission. As a result, Circularly Disposed Antenna Array Buildings contained within inventory are in the process of being demolished, or are have been converted for use in other category codes. Category Code 131 55 is provided for information purposes only.

131 56 DIRECTION FINDER BUILDING (SF)**FAC: 1311****BFR Required: N**

13156-1 **DEFINITION.** A Direction Finder Building is a High Frequency Direction Finding (HFDF) facility that contains the tuning and receiving equipment associated with the AN/FRD-13 antennas. It is associated with functions performed by various DON Communications, Intelligence, and Operational missions. Unlike the CDAA (131-55), the Direction Finder Building is not located within the center of the AN/FRD-13 array, and it contains very limited personnel support space, maintenance space, and storage space. The AN/FRD-13 requires specific siting criteria as outlined in NSGINST 2450.1.

13156-2 DON no longer maintains a HFDF mission. As a result, Direction Finder Buildings contained within inventory are in the process of being demolished, or are have been converted for use in other category codes. Category Code 131 56 is provided for information purposes only and should not be used.

131 60 MILITARY AFFILIATE RADIO STATION (MARS) (SF)**FAC: 1311****BFR Required: N**

13160-1 This category code is for inventory purposes only until the function is either absorbed into Category Code 131 15 or is eliminated completely and facilities are reassigned to other functions.

131 65 COMMUNICATIONS ANALYSIS FACILITY (SF) [DELETE]
FAC: 1311
BFR Required: Y

13165-1 This category is deleted. All future requirements should be reassigned and revised to Category Code 13115 “Communications, Information, or Intelligence Analysis Facility.”

132 COMMUNICATIONS-OTHER THAN BUILDINGS

132-1 This facility group encompasses radio antennas, switching stations and public address systems. The antennas required are a function of the number and type of radio circuits to be incorporated in the communications system.

132 10 ANTENNA-COMMUNICATIONS (EA)
FAC: 1321
BFR Required: N

13210-1 Planning for communications antennas involves consideration of three basic aspects: siting, selection of types, and structures for support.

13210-2 Requirements for siting, arrangements, types of antennas, circuitry, and other aspects, are determined by the Space and Warfare Systems Command (SPAWAR) and the office having support responsibility. The antenna types and their heights are:

Uniform lattice (guyed)	to 1500 feet
Uniform lattice (self-supporting)	to 600 feet
Pole	to 220 feet

13210-3 Vertical radiators make use of the tower structure as the radiator. The SPAWAR Systems Command provides the electronic specifications for vertical radiator antennas. The Naval Facilities Engineering Command provides the structural design.

13210-4 The majority of antenna installations used at radio communications facilities are tower/pole and wire construction. These are:

- Antenna system supported between self-supporting or guyed towers, transmitting/receiving
- Vertical radiator, transmitting only
- Rhombic, transmitting/receiving
- Tilted folded doublet transmitting/receiving
- Vee, transmitting/receiving
- Horizontal LF, transmitting/receiving

- Vertical doublet transmitting/receiving
- Horizontal parasitic doublet, transmitting/receiving
- Horizontal two-wire doublet, transmitting only
- Horizontal three-wire doublet, transmitting only
- Various UHF and VHF antennas
- Rotatable log periodic, transmitting/receiving (tower supported)
- Horizontal log periodic, transmitting/receiving (tower supported)
- Vertical log periodic, transmitting/receiving (tower supported)
- Conical monopole, transmitting/receiving (tower supported)
- Discone, transmitting/receiving
- Inverted cone, transmitting/receiving
- Wire grid lens, receiving only
- Wullenweber, receiving only (Code 132 55)
- High take off angle, transmitting/receiving (tower supported)
- Hermes loop array, receiving only
- Umbrella top-loaded monopole, transmitting (tower supported)
- Inverted-L, transmitting (tower supported)
- T-antennas, transmitting (tower supported)
- Various VLF antennas, transmitting/receiving

132 50 PUBLIC ADDRESS SYSTEM - OUTDOOR (EA)

FAC: 1321

BFR Required: N

Design Criteria: UFC 4-021-01, Design and O&M: Mass Notification Systems

13250-1 Outdoor public address systems will be planned and installed to meet individual needs of a facility.

132 55 CIRCULARLY DISPOSED ANTENNA ARRAY (WULLENWEBER) (EA)

FAC: 1321

BFR Required: N

13255-1 This antenna array is generally planned in conjunction with a Circularly Disposed Antenna Array Building. See Category Code 131 55 for additional guidance.

13255-2 The Department of Navy no longer maintains a HFDF mission. As a result, Circularly Disposed Antenna Arrays contained within inventory are in the process of being demolished or are have been converted for use in other category codes. Category Code 132 55 is provided for information purposes only and should not be used.

133 NAVIGATION AND TRAFFIC AIDS – BUILDINGS (NON-SHIP RELATED)

133-1 **DESCRIPTION.** Basic Category Code group 133 applies to those Air Traffic Control Facilities (ATCFs) that contain the equipment, devices, and personnel responsible for air traffic control and navigational aids. This group discusses complete air traffic control classes and systems, which are defined below. Other elements of air traffic control and navigation aids that are remotely located around the airfield can be found in the 133, 134 and 135 series of Category Codes.

133-1.1 **Air Traffic Control Facility (ATCF).** The ATCF includes personnel and equipment associated with the operation of the following:

- Control Tower
- Approach Control
- Terminal Radar
- En Route Radar
- Flight Planning
- Air Navigational Aids

The standard ATCF serves as the foundation for all other ATCF planning standards by establishing a common baseline for ACTF resource determinations. Addressed within the standard are the needs for ATCF classification, the concepts used for standard development, descriptions of the services provided by ATCFs and definitions of the resulting six ATCF classes.

133-1.2 **ATCF Classification Scheme.** The approach to standard development, by definition, is the process of arranging items into groups based on the systematic division of common traits. The underlying principle for establishing a classification scheme is that each resultant class must encompass common elements. Since Navy Air Traffic Control (ATC) is one of a large number of closely interrelated elements collectively supporting the naval aviation mission, the classification scheme must identify all elements that bear upon the performance of ATC and analyze each for commonality across the spectrum of ATCFs. The ATCF classification scheme, by segregating ATC services into groups, establishes six major classes as shown in Table 133-1.

Table 133-1 ATCF Classification Scheme

Class	Description
Class I	Flight Planning Facility
Class II	Control Tower Facility
Class III	Control Tower with Ground Control Approach (GCA) Facility (Class III ATCFs

Class	Description
	can be further identified by GCA pattern control authority, i.e., with or without)
Class IV	Approach Control Facility
Class V	Joint Control Facility
Class VI	Fleet Area Control and Surveillance Facility

133-1.3 **ATC Services.** ATC services include five distinct directives that are provided slightly or in combination at every ATCF:

133-1.3.1 **Flight Assistance Service.** The planning of a flight is the first element of an air operation. Safety of flight is dependent on thorough flight planning covering itinerary, times, and weather. Flight assistance services interface the flight crew with the air traffic control system and encompass work, space, personnel, equipment, and information related to:

- Planning a flight.
- Introducing the plan into the ATC system.

133-1.3.2 **Airport Traffic Control Service.** Airport traffic control encompasses those services provided to aircraft operating within the airport traffic area or on the airport surface. They include:

- Issuing control instructions to provide sequencing to assure the orderly and expeditious movement of aircraft departing, landing, or approaching the airport or landing.
- Furnishing information to pilots concerning clearances to operate aircraft, weather and field conditions, and pertinent operating and procedural instructions.
- Relaying aircraft operation and control messages between pilots and other air traffic facilities.
- Notifying crash and rescue agencies during actual or potential accidents on or in the vicinity of the airport. These services are somewhat unique as they are the only services that are location sensitive; using today's technology, they also require an elevated structure and visual contact.

133-1.3.3 **Low Approach and Landing Service.** This service permits aircraft to be recovered when weather ceilings and visibility are less than that prescribed for Instrument Approach Procedures (IAPs) predicated on the non-precision air navigational aids. The service encompasses:

- Issuing control instructions to provide separation to aircraft approaching for landing under marginal weather conditions.
- Providing control instructions and information to align aircraft in azimuth and altitude so an optimum touchdown point on the landing surface may be reached.

133-1.3.4 Terminal Area Control Service. Terminal area control services provide separation and control of aircraft operating in the relatively dense air traffic environment surrounding major airports. Services are exclusive to those performed as part of airport traffic control and low approach and landing services. This service includes:

- Separation and control of departing and arriving aircraft operating under Instrument Flight Rules (IFR).
- Separation and control of transiting aircraft operating under IFR.
- Separation and control of aircraft operating under Visual Flight Rules (VFR) that desire the added margin of safety afforded by such control.

133-1.3.5 Range Control (Air) Service. Range control (air) services combine both ATC in the classic sense, i.e., separating aircraft from each other or obstructions, and the provisions of combat direction and/or range surveillance. Services are mission-oriented and encompass:

- Mission aircraft flight-following.
- Mission aircraft direction.
- National Airspace System Interface.

133-1.4 ATCF Class Definitions.

133-1.4.1 Class I. Flight Planning Activity (also known as an Air Operations Building, Category Code 141 40). An ATCF organized, manned, and equipped to provide flight assistance services to aircrews including flight planning and flight safeguarding services. The air operations building is generally located on the edge of the airfield adjacent to the air traffic control tower and Military Terminal Radar Approach Control Facility (MTRACON), Category Code 133-72.

133-1.4.2 Class II. Control Tower (Category Code 141 70). An ATCF organized, manned, and equipped to provide airport traffic control services including: air traffic sequencing to aircraft airborne within the airport traffic area; authority for aircraft to land or takeoff from runways, or heliports; and control of aircraft and vehicles on the surface within the movement area to ensure safe, orderly, and expeditious aircraft movement. Unless modified by letter of agreement, the air traffic control clearance authority vested in the tower is limited to that permitted operation in accordance with VFR; although IFR or special VFR air traffic control clearances, originated by other tower facilities having such authority, may be relayed by the tower. Flight assistance services may also be provided. The air traffic control tower facility is generally located on the edge of the airfield, situated to have an unobstructed line-of-sight to the aircraft approach areas, runways, taxiways, aircraft parking areas, and other operational areas over which aircraft movements are to be controlled. Provide tower location and height to result in lower cab eye level line of site intersecting airport traffic surfaces at a vertical angle of 35 minutes or greater.

133-1.4.3 **Class IIIA/IIIB.** Control Tower/Ground Control Approach (GCA) Facility (also referred to as a Radar Air Traffic Control Facility (RATCF), Category Code 133 71). An ATCF is organized, manned, and equipped to provide air traffic control and low approach and landing services, including: air traffic sequencing to aircraft airborne within the airport traffic area; authority for aircraft to land or takeoff from runways, or heliports; control of aircraft and vehicles on the surface within the movement area; and control instructions to aircraft during the intermediate and final approach segments (Class IIIA) to ensure safe, orderly, and expeditious aircraft movement. Unless modified by letter of agreement, the air traffic control clearance authority vested in the control tower is limited to that permitted for operation in accordance with VFR, although IFR and special VFR air traffic control clearances, originated by other facilities having such authority, may be relayed or issued. Likewise, GCA control authority may be extended beyond the intermediate fix when authorized by letter of agreement (Class IIIB). Flight assistance services may also be provided. This facility is generally located adjacent to the air traffic control tower.

133-1.4.4 **Class IV.** Approach Control Facility (also referred to as a Military Terminal Radar Approach Control Facility (MTRACON), Category Code 133-72). An ATCF organized, manned, and equipped to provide airport traffic control and terminal area services including: separation and control to arriving, departing, and occasionally en route aircraft operating in accordance with IFR and, when appropriate, VFR within airspace assigned for the purpose by letter of agreement, to ensure safe, orderly, and expeditious aircraft movement. Service to the primary airport include: air traffic sequencing to airborne aircraft within the traffic area; authority for aircraft to land or take off from runways or heliports; and control of aircraft and vehicles on the surface within the movement area. These facilities are authorized to originate IFR and special VFR air traffic control clearances for aircraft landing and departing airports within their assigned area of responsibility or transiting airspace under their control jurisdiction, including instrument approach and departure clearances. They may also provide low approach and landing and flight assistance services. This facility is generally located adjacent to the air traffic control tower and aircraft operations building where site requirements permit.

133-1.4.5 **Class V.** Joint Control Facility (JCF) (Category Code 133 74). A combined air ATCF and Range Operations Center (ROC), organized, manned, and equipped to provide Class II, IIIA/B, or IV services and range control services. ROC services may include: aircraft control, separation, positioning, tracking, and target scoring. ROC operational jurisdiction is typically limited to special use airspace (restricted areas, Military Operations Areas (MOAs), or ATC Assigned Airspace (ATCAA)). The JCF is located adjacent to the air operations building when site criteria allows. An air traffic control tower may be sited with the JCF.

133-1.4.6 **Class VI.** Fleet Area Control and Surveillance (FACSFAC) (Category Code 133 73). A FACSFAC is an ATCF facility defined as an organization of personnel and equipment designated, equipped, and manned to manage offshore and inland operating areas, as required, dedicated for military use. The mission of a FACSFAC is to manage military use of Offshore Operating Areas (OPAREAS) through coordination, scheduling, and control, if applicable, of subsurface, surface, and airborne military platforms operating within and transiting to and from these areas. FACSFACs are established as an intermediate level facility between that of a Military Radar Unit (MRU) and an ATCF. Prior to being upgraded from a MRU level facility to an intermediate level ATCF, FACSFACs must comply with the following requirements:

- Possess flight check data depicting areas of radio/radar coverage.
- Possess radar/radio communication redundancy in areas routinely used for national airspace interface.
- Validate operator training programs by assuring compliance with FAA, OPNAV, and FACSFAC personnel qualification standards.
- Implement comptroller certification standards in compliance with FAA publications and the OPNAVINST 3721.1K.
- Possess auxiliary power to support the Fleet Area Control System (FACS) in the event of loss of commercial power.
- Obtain FACS interface certification with the FAA.

Each FACSFAC is tailored to meet the operational needs of a specific area in direct support of the fleet operational requirements. For purposes of identification, equipment and personnel control, each FACSFAC, at time of commissioning, is placed under the operational control of the supported command; administrative control is through the local commander; and technical support is received from Naval Electronic Systems Command (NAVELEX). Each FACSFAC is a stand-alone facility. Table 133-2 defines each of the six different types of ATCFs with their respective facility nomenclature in tabular form.

Table 133-2. ATCF Classes and Facility Nomenclature

Class ATC Facility	Air Operations Building	Control Tower	RATCF	MTRACON	JCF	FACSFAC
1	X					
2	X	X				
3	X	X	X			
4	X	X		X		
5	X	X			X	
6						X

133 15 RADAR WIND SOUNDING (RAWIN) BUILDING**FAC: 1331****BFR Required: Y**

13315-1 **DEFINITION.** A RAWIN building (Radar Wind Sounding) is a specialized weather reporting facility. It houses tracking equipment used in conjunction with balloon-borne radiosonde transmitters.

13315-2 **GENERAL.** An engineering analysis is required to determine facility space allocations.

133 20 VERY HIGH FREQUENCY (VHF) OMNI-DIRECTIONAL RANGE (VOR) FACILITY (M2/SF)**FAC: 1331****BFR Required: Y**

Design Criteria: UFC 4-141-10N, Aviation Operation and Support Facilities

Planning Criteria: P-80.3, Airfield Safety Clearances (Facility Planning Factor Criteria for Navy and Marine Corps Shore Installations, Appendix E)

13320-1 **DEFINITION.** The Very High Frequency (VHF) Omni-Directional Range (VOR) building houses a VHF, fixed ground-based station which continuously transmits bearing, identification, and with proper equipment, distance information to properly equipped aircraft.

13320-2 **REQUIREMENTS.** A gross area of 28 M2 (300 SF) is provided for the electronic equipment, monitoring and test equipment, and mechanical equipment. A vehicle access road is required.

13320-3 **SITE PLANNING.** Any facility located within the Airfield Safety Clearance Zone as defined by NAVFAC P-80.3 requires a criteria waiver approved by COMNAVAIRSYSCOM (Code 09Y1). Any equipment that must be located in violation of the Safety Clearance Zone criteria shall be coordinated with the In Service Engineering Agent (ISEA). The ISEA must ensure that such equipment will be sited as far as possible away from the operating surface toward the outer limits of the NAVFAC P-80.3 criteria.

133 25 TACTICAL AIR NAVIGATION (TACAN) BUILDING (M2/SF)**FAC: 1331****BFR Required: Y**

Design Criteria: UFC 4-141-10N, Aviation Operation and Support Facilities

Planning Criteria: P-80.3, Airfield Safety Clearances (Facility Planning Factor Criteria for Navy and Marine Corps Shore Installations, Appendix E)

13325-1 **DEFINITION.** The Tactical Air Navigation (TACAN) Building houses UHF ground-based station which transmits bearing, identification, and distance information to

properly equipped aircraft. The TACAN is primarily a military short-range 322 km (200 mile) navigational aid that is generally planned for each Navy and Marine Corps air station.

13325-2 **REQUIREMENTS.** A TACAN building is not required at those air stations which can be serviced by a TACAN or VORTAC of a nearby airfield, either military or civilian. A gross area of 28 M2 (300 SF) is provided for the electronic equipment, monitoring and test equipment, and mechanical equipment. A vehicle access road is required.

13325-3 **SITE PLANNING.** Any facility located within the Airfield Safety Clearance Zone as defined by NAVFAC P-80.3 requires a criteria waiver approved by COMNAVAIRSYSCOM (Code 09Y1). Any equipment that must be located in violation of the Safety Clearance Zone criteria shall be coordinated with the In Service Engineering Agent (ISEA). The ISEA must ensure that such equipment will be sited as far as possible away from the operating surface toward the outer limits of the NAVFAC P-80.3 criteria.

133 30 VERY HIGH FREQUENCY (VHF) OMNI-DIRECTIONAL RANGE/TACTICAL AIR NAVIGATION (VORTAC) BUILDING (M2/SF)

FAC: 1331

BFR Required: Y

Design Criteria: UFC 4-141-10N, Aviation Operation and Support Facilities

Planning Criteria: P-80.3, Airfield Safety Clearances (Facility Planning Factor Criteria for Navy and Marine Corps Shore Installations, Appendix E)

13330-1 **DEFINITION.** The Very High Frequency (VHF) Omni-Directional Range/Tactical Air Navigation (VORTAC) Building houses VHF/UHF fixed ground-based station that continuously transmits bearing, identification, and distance information to properly equipped aircraft when distance measuring equipment (DME) is installed.

13330-2 **REQUIREMENTS.** A gross area of 28 M2 (300 SF) is provided for the electronic equipment, monitoring and test equipment, and mechanical equipment. A vehicle access road is required.

13330-3 **SITE PLANNING.** Any facility located within the Airfield Safety Clearance Zone as defined by NAVFAC P-80.3 requires a criteria waiver approved by COMNAVAIRSYSCOM (Code 09Y1). Any equipment that must be located in violation of the Safety Clearance Zone criteria shall be coordinated with the In Service Engineering Agent (ISEA). The ISEA must ensure that such equipment will be sited as far as possible away from the operating surface toward the outer limits of the NAVFAC P-80.3 criteria.

133 35 NON-DIRECTIONAL BEACON (NDB) FACILITY (M2/SF)**FAC: 1331****BFR Required: Y**

Design Criteria: None Available.

Planning Criteria: P-80.3, Airfield Safety Clearances (Facility Planning Factor Criteria for Navy and Marine Corps Shore Installations, Appendix E)

13335-1 **DEFINITION.** This Non-Directional Beacon (NDB) facility is an unattended facility which houses electric equipment (radio beacon) used to transmit a non-directional radio signal pattern to aircraft equipped with Automatic Radio Direction and Finding (ADF) equipment. The signal is used by the aircraft for homing and radio fix assistance. The radio beacon may be employed for voice or tone modulated transmission. The facility consists of an equipment building with adjoining or adjacent space with emergency standby power and an antenna mounted on an antenna support.

13335-2 **REQUIREMENTS.** The facility is required at all Navy and Marine Corps air stations unless other navigational aid facilities obviate the need. The NDB is located on or adjacent to the airport. Metal buildings, power lines, or metal fences should be kept a minimum of 30.5 meters (100 feet) from the NDB antenna. The building area is 11.2 M2 (120 gross SF) and requires an antenna support.

13335-3 **SITE PLANNING.** NDB may be located either on or off the station with specific siting satisfactory to NAVAIRSYSCOM and NAVELEXSYSCOM.

133 65 AIR NAVIGATION BUILDING (M2/SF)**FAC: 1331****BFR Required: Y**

Design Criteria: None Available.

Planning Criteria: P-80.3, Airfield Safety Clearances (Facility Planning Factor Criteria for Navy and Marine Corps Shore Installations, Appendix E)

13365-1 **DEFINITION.** An Air Navigation Building is a specialized facility for providing a readily available source of operational and aeronautical intelligence information; storage and issue of aeronautical maps and charts; and secure storage of classified material up to TOP SECRET documents.

13365-2 **REQUIREMENTS.** There are two types of air navigation buildings:

13365-2.1 **Type A Building.** A Type A building requires a gross area of 417 M2 (4,487 SF) and is planned for flight support air stations having an area command mission.

13365-2.2 **Type B Building.** A Type B building requires a gross area of 1,010 M2 (10,863 SF) and is planned for those stations having logistics support for a major area command such as COMNAVAIRLANT or COMNAVAIRPAC.

13365-3 **SECURE STORAGE.** Secure storage areas are provided in conformance with OPNAVINST 5510.1 (latest revision).

133 71 RADAR AIR TRAFFIC CONTROL FACILITY (RATCF) (M2/SF)

FAC: 1331

BFR Required: Y

Design Criteria: UFC 4-141-10N, Aviation Operation and Support Facilities

Planning Criteria: P-80.3, Airfield Safety Clearances (Facility Planning Factor Criteria for Navy and Marine Corps Shore Installations, Appendix E)

13371-1 **DEFINITION.** The Radar Air Traffic Control Facility (RATCF) provides housing for equipment and personnel to support Instrument Flight Rules (IFR) control of aircraft on approach to or departure from the terminal radar facility or airport. Other functions include Precision Approach Radar (PAR) for landing aircraft during inclement weather and limited visibility. It provides space for an IFR control room that contains radar display consoles and communications terminals, equipment rack storage for communications terminal equipment, a ready room for Air Traffic Control (ATC) watch standers, a training room, and office area for supervision and control.

13371-1.1 **Components.** The RATCF, a Class IIIA/IIIB activity, contains the Control Tower/Ground Controlled Approach (GCA) Facility. An Air Traffic Control Facility (ATCF) organized, manned, and equipped to provide air traffic control and low approach and landing services, including:

- Air traffic sequencing to aircraft airborne within the airport traffic area.
- Authority for aircraft to land or takeoff from runways or heliports.
- Control of aircraft and vehicles on the surface within the movement area.
- Control instructions to aircraft during the intermediate and final approach segments (Class IIIA) to ensure safe, orderly, and expeditious aircraft movement.

13371-1.2 **Control Authority.** Unless modified by letter of agreement, the air traffic control clearance authority vested in the control tower is limited to that permitted for operation in accordance with Visual Flight Rules (VFR), although IFR and special VFR air traffic control clearances, originated by other facilities having such authority, may be relayed or issued. Likewise, GCA control authority may be extended beyond the intermediate fix when authorized by letter of agreement (Class IIIB). Flight assistance services may also be provided. Consult Basic Category Code 133 information for additional ATCF class information.

13371-2 **REQUIREMENTS.** The facility space allowance is 402 M2 (4,320 SF) gross area which includes mechanical equipment room.

13371-3 **SITE PLANNING.** The facility should be sited adjacent to the air traffic control tower when site conditions permit.

**133 72 MILITARY TERMINAL RADAR APPROACH CONTROL FACILITY
(MTRACON) (FORMERLY RATCC CENTER) (M2/SF)**

FAC: 1331

BFR Required: Y

Design Criteria: UFC 4-141-10N, Aviation Operation and Support Facilities

Planning Criteria: P-80.3, Airfield Safety Clearances (Facility Planning Factor Criteria for Navy and Marine Corps Shore Installations, Appendix E)

13372-1 **DEFINITION.** A Military Terminal Radar Approach Control (MTRACON) Facility is used to control air traffic to provide safe, expeditious, and orderly movement of aircraft under all weather conditions. Justification for a MTRACON is established by the Chief of Naval Operations.

13372-1.1 **Components.** The MTRACON is a Class IV, Approach Control, Air Traffic Control Facility (ATCF). An ATCF is organized, manned, and equipped to provide airport traffic control and terminal area services including:

- Separation and control to arriving, departing, and occasionally en route aircraft operating in accordance with Instrument Flight Rules (IFR) and, when appropriate, Visual Flight Rules (VFR) within airspace assigned for the purpose by letter of agreement, to ensure safe, orderly, and expeditious aircraft movement.
- Air traffic sequencing to aircraft airborne within the airport traffic area.
- Authority for aircraft to land or takeoff from runways or heliports.
- Control of aircraft and vehicles on the surface within the movement area.
- Control instructions to aircraft during the intermediate and final approach segments (Class IIIA) to ensure safe, orderly, and expeditious aircraft movement.

These facilities are authorized to originate IFR and special VFR air traffic control clearances for aircraft landing or departing airports within their assigned area of responsibility or transiting airspace under their control jurisdiction, including instrument approach and departure clearances. They may also provide low approach and landing and flight assistance services. Consult Basic Category 133 information for additional ATCF class information.

13372-1.2 **Operation of a MTRACON.** NAVAIR 00-80T-114 promulgates policies affecting the establishment and operation of a MTRACON and its component radar systems. The area of jurisdiction for a MTRACON facility extends beyond the area of responsibility assigned to a Radar Air Traffic Control Facility (RATCF).

13372-2. The MTRACON radar facilities may consist of the Air Surveillance Radar (ASR) facility, Category Code 133 75, the Air Route Surveillance Radar (ARSR) facility, Category Code 133 76, and the Precision Approach Radar (PAR), Category Code 134 40, located on a turntable. Video information from each of these radars is transmitted to remote monitors in the MTRACON and control tower by underground cable or microwave relay.

13372-3 **SITE PLANNING.** Wherever practicable it is highly desirable that the MTRACON, the Control Tower, Attached/Free Standing, Category Code 141 70, and the Aircraft Operations Building, Category Code 141 40, be located together as an integral unit. If site conditions dictate the separation of the Air Operations Building and the Control Tower, the MTRACON should be collocated with the control tower, creating an integrated air traffic control facility.

13372-4 **REQUIREMENTS.** The MTRACON requires a gross area of 1,230 M² (13,200 SF). The nerve center of the MTRACON is the control room which contains the radar monitors and communications modules. A radar and communications terminal equipment room houses the audio and video tape recorders as well as the automation central (or terminal) equipment. An office for the FAA liaison officer, training classroom, a ready room for radar controllers on work breaks, a Combined radar/ training chief office, leading chief office, MTRACON equipment maintenance and office space, an air traffic control officer's office, and a proficiency trainer room are also provided. Space is also provided in the mechanical room for an emergency generator system and Uninterruptible Power Supply (UPS) system.

133 73 FLEET AREA CONTROL SURVEILLANCE FACILITY (M²/SF)

FAC: 1331

BFR Required: Y

Design Criteria: UFC 4-141-10N, Aviation Operation and Support Facilities

Planning Criteria: P-80.3, Airfield Safety Clearances (Facility Planning Factor Criteria for Navy and Marine Corps Shore Installations, Appendix E)

13373-1 **DEFINITION.** The Fleet Area Control Surveillance Facility (FACSFAC) building houses the FACSFAC Tracking System (FACTS) and Navy Tactical Data System/Advanced Combat Direction System (NTDS/ACDS) equipment and personnel to provide a variety of services to air, surface and subsurface units. These services are provided to both military and civilian users and include radar surveillance and various forms of air traffic control in warning and other special airspace areas. Other services include:

- Surface operating area management.
- Ground controlled intercept.
- Operating area scheduling.
- Range control.

The FACSFAC normally operates continuously, 24 hours per day, and 7 days per week.

13373-1.1 **Components.** The FACSFAC is a Class VI Air Traffic Control Facility (ATCF) and is defined as an organization of personnel and equipment designated, equipped, and manned to manage offshore and inland operating areas, as required. The mission of a FACSFAC is to manage military use of Offshore Operating Areas (OPAREAS) through coordination, scheduling, and control, if applicable, of subsurface, surface, and airborne military platforms operating within and transiting to and from these areas. FACSFACs are established as an intermediate level facility between that of a Military Radar Unit (MRU) and an ATCF. Prior to being upgraded from a MRU level facility to an intermediate level ATCF, FACSFACs must comply with the following requirements:

- Possess flight check data depicting areas of radio/radar coverage.
- Possess radar/radio communication redundancy in areas routinely used for national airspace interface.
- Validate operator training programs by assuring compliance with FAA, OPNAV, and FACSFAC personnel qualification standards.
- Implement comptroller certification standards in compliance with FAA publications, the OPNAVINST 3721.1K, and the NAVAIR 00-80T-114.
- Possess auxiliary power to support the Fleet Area Control System (FACS) in the event of loss of commercial power.
- Obtain FACS interface certification with the FAA.

Consult Basic Category Code series 133 for additional ATCF information.

13373-1.2 **Operational Organization.** Each FACSFAC is tailored to meet the operational needs of a specific area in direct support of the fleet operational requirements. For purposes of identification, equipment and personnel control, each FACSFAC, at time of commissioning, is placed under the operational control of the supported command; administrative control is through the local commander; technical support is received from Naval Electronic Systems Command (NAVELEX).

13373-1.3 **Functions.** The FACSFAC functions include:

- Radar Air Traffic Control and Area Management.
- Communications Monitoring and Control.
- Command Administration.
- Equipment Maintenance.
- Training and Briefings
- Computer Systems Management and Engineering.

13373-2 **SITE PLANNING.** Facility normally stands alone and can be sited either on or off Station.

13373-3 **REQUIREMENTS.** The standard size of the FACSFAC building is 2,570 M2 (27,650 SF) gross area. The mechanical space should include sufficient room for an emergency generator system and an Uninterruptible Power Supply (UPS) system. The

size of the facility should be adjusted in accordance with the specific mission and number of personnel assigned.

133 74 JOINT CONTROL FACILITY (M2/SF)

FAC: 1331

BFR Required: Y

Design Criteria: UFC 4-141-10N, Aviation Operation and Support Facilities
Planning Criteria: P-80.3, Airfield Safety Clearances (Facility Planning Factor Criteria for Navy and Marine Corps Shore Installations, Appendix E)

13374-1 **DEFINITION.** The Joint Control Facility (JCF) is an air traffic control facility, a Radar Air Traffic Control Facility (RATCF), and a Range Operations Center (ROC) under one roof.

13374-1.1 **Components.** The JCF is a Class V Air Traffic Control Facility (ATCF). It is a combined air ATCF and ROC, organized, manned, and equipped to provide Class II, IIIA/B, or IV services and range control services. ROC services may include aircraft control, separation, positioning, tracking, and target scoring. ROC operational jurisdiction is typically limited to special use airspace (restricted areas, Military Operations Areas (MOAs), or ATC Assigned Airspace (ATCAA). The JCF is located adjacent to the air operations building when siting criteria allows. An air traffic control tower may be sited with the JCF. Consult Basic Category Code group 133 for additional ATCF class information.

13374-2 **REQUIREMENTS.** The specific functional areas to be provided include a main operations room where air traffic control radar display monitors and communications terminals are located; adjacent equipment spaces for communications devices, recorders and navigational aids; maintenance spaces for Ground Electronics Maintenance Division (GEMD) support personnel; and administrative spaces for command functions, training and personnel administration. The mechanical spaces should include sufficient space for an emergency generator system and Uninterruptible Power Supply (UPS) system. See Table 13374-1 for space allowances for the JCF facility.

Table 13374-1. Joint Control Facility Space Allowances

Type of Facility	Gross Area	
	M2	SF
Medium Density	3,156	33,970
High Density	3,670	39,500

13374-3 **SITE PLANNING.** The JCF should be located adjacent to the Air Operations Building when site conditions permit. The Air Traffic Control Tower, Category Code 141 70, should be sited with the JCF.

133 75 AIR SURVEILLANCE RADAR (ASR) FACILITY (M2/SF)**FAC: 1331****BFR Required: Y****Design Criteria:** UFC 4-141-10N, Aviation Operation and Support Facilities**Planning Criteria:** P-80.3, Airfield Safety Clearances (Facility Planning Factor Criteria for Navy and Marine Corps Shore Installations, Appendix E)

13375-1 **DEFINITION.** The Air Surveillance Radar (ASR) facility is an unattended facility which serves as a major component of the Radar Air Traffic Control Facility (RATCF), Category Code 133 71; the Military Terminal Approach Control Facility (MTRACON), Category Code 133 72; and the Joint Control Facility (JCF), Category Code 133 74. It provides detection and identification for control of aircraft operating in a line-of-sight range and altitudes determined by system design. The system also provides azimuth and range data and is remotely controlled by the air traffic control personnel via underground cables or microwave link. It consists of a rotating radar antenna mounted on a supporting tower, a transportable building which houses the electronic equipment, and a standby power plant installed in a separate transportable shelter. The facility and its antenna are located under the direction of Naval Electronics Systems Command (NAVELEX) and defined in the Base Electronic Systems Engineering Plan (BESEP).

13375-2 **SITE PLANNING.** The ASR is the standard terminal air traffic control surveillance radar for the Navy, Air Force, and FAA. It is a separate facility, housing radar transmitting, receiving, and monitoring equipment and maintenance personnel to provide detection and identification of aircraft transiting the area or executing and instrument approach or departure. The building and its associated antenna tower are located in a remote area of the airfield and an access road and emergency generator are required. Information derived from the ASR is transmitted to the MTRACON, RATCF, or JCF by underground cable or microwave link, and the ASR is remotely controlled from the MTRACON, RATCF, or JCF.

13375-3 **REQUIREMENTS.** The ASR facility has a gross area of 130 M2 (1,400 SF) including mechanical equipment room.

133 76 AIR ROUTE SURVEILLANCE RADAR (ARSR) FACILITY (M2/SF)**FAC: 1331****BFR Required: Y****Design Criteria:** UFC 4-141-10N, Aviation Operation and Support Facilities**Planning Criteria:** P-80.3, Airfield Safety Clearances (Facility Planning Factor Criteria for Navy and Marine Corps Shore Installations, Appendix E)

13376-1 **DEFINITION.** The Air Route Surveillance Radar (ARSR) facility houses the electronic long range radar system used to obtain the range and azimuth of an aircraft. When equipped with an Air Traffic Control Radar Beacon System (ATCRBS), the Air Route Surveillance Radar System (ARSR) obtains altitude and identification of the aircraft. The ARSR has a range greater than that of an ASR, and as such, is used

primarily for Fleet Area Control and Surveillance Facility (FACSFAC), Category Code 133 73 or Joint Control Facility (JCF), Category Code 133 74 functions. This facility is similar to the Air Surveillance Radar (ASR) facility, Category Code 133 75; the difference being that an ARSR is used to monitor a larger piece of airspace than an ASR. An ASR only controls overflight, approach, and departure flight paths at a terminal facility.

13376-2 **SITE PLANNING.** The ARSR building should be located adjacent to the radar facility antenna tower.

13376-3 **REQUIREMENTS.** The facility provides space primarily for the radar equipment systems, a small work bench for maintenance of system equipment, storage areas for spare parts and restroom if required. The ARSR facility has an gross area of 174 M2 (1,876 SF), including mechanical equipment room.

133 80 WHEELS WATCH SHELTER (EA)

FAC: 1331

BFR Required: Y

Design Criteria: Not Available

Planning Criteria: P-80.3, Airfield Safety Clearances (Facility Planning Factor Criteria for Navy and Marine Corps Shore Installations, Appendix E)

13380-1 **DESCRIPTION.** A portable wheels watch booth is provided with the runway Wheels-Up/Wave-Off Lighting system, Category Code 136 45. The shelter is located approximately 302 meters (990 feet) short of the runway threshold near the wheels-up/wave-off lighting system. The facility may be either a trailer or truck. Due to its location and access road and pad may be required and the shelter is an obstruction to airfield safety criteria, therefore a waiver is required from Naval Air Systems Command (NAVAIRSYSCOM) prior to its installation. Normally this requirement will be satisfied by portable equipment, Class III Property. However, this code may be used for planning purposes.

134 NAVIGATION AND TRAFFIC AIDS - OTHER (NON - SHIP RELATED)

134-1 **DEFINITION.** Basic Category Code group 134 applies to structures which function as aircraft navigation/ traffic aids.

134 10 ANTENNA - NAVIGATION (EA)

FAC: 1341

BFR Required: N

Design Criteria: Not Available

Planning Criteria: P-80.3, Airfield Safety Clearances (Facility Planning Factor Criteria for Navy and Marine Corps Shore Installations, Appendix E)

13410-1 **DESCRIPTION.** An antenna system for navigation aid will vary with the type and purpose of the navigational aid. This Category Code shall be used to indicate entire antenna systems.

13410-2 **REQUIREMENT.** No specific planning factors are applicable.

134 20 AIRPORT AND/OR HELIPORT BEACON (EA)

FAC: 1341

BFR Required: N

Design Criteria: FAA AC 150/5345-12C; NAVAIR 51-50AAA-12

Planning Criteria: P-80.3, Airfield Safety Clearances (Facility Planning Factor Criteria for Navy and Marine Corps Shore Installations, Appendix E)

13420-1 **DEFINITION.** An airport and/or heliport beacon is an internationally recognized rotating or flashing illuminated beacon operated as a visual aid to air navigation to assist aircrews in locating and identifying airports and/or heliports. Basic criteria on usage of airport and/or heliport beacons may be found in Federal Aviation Administration Advisory Circular 150/5345-12 (L-801H), (L-802A), and (L-803A) Specifications for Airport and Heliport Beacons.

13420-2 **REQUIREMENTS.** Three functional types of airport and/or heliport beacons are: airport rotating, identification or code, and heliport beacons. Requirements for each type are as follows:

13420-2.1 **Airport Rotating Beacon.** This is required for each airfield; with exception that two adjacent airfields may have a common beacon. A lighted military airport is identified by a beacon showing alternate flashes of two white and one green light. An unlighted military airport is identified by white flashes only.

13420-2.2 **Identification or Code Beacon.** This is required when the airport beacon is more than 1,520 meters (5,000 feet) from the nearest point of the usable landing area or where two or more adjacent airfields use one common airport beacon. The identification or code beacon is non-rotating and flashes a signal, the code and color of which identify the field. Where a heliport is not part of an airfield and an operational requirement has been established, an identification beacon is required.

13420-2.3 **Heliport Beacon.** This is a rotating beacon that provides identification for a lighted heliport when it is not clearly associated with an airfield. The beacon should alternately flash white, green, and yellow. It is not to be installed within one mile of an existing airfield beacon or runway.

13420-2.4 **Hazard Beacon.** A hazard or obstruction beacon is a non-rotating beacon with a flashing red light used where special warning is required to identify a

hazard to air navigation and is incorporated in Category Code 134 50, Obstruction Lighting, Aircraft.

134 40 GROUND CONTROL APPROACH SYSTEM (EA)

FAC: 1341

BFR Required: Y

Design Criteria: UFC 4-141-10N, Aviation Operation and Support Facilities

Planning Criteria: P-80.3, Airfield Safety Clearances (Facility Planning Factor Criteria for Navy and Marine Corps Shore Installations, Appendix E)

13440-1 **DEFINITION.** A Ground Control Approach (GCA) System is a radar approach system operated from the ground by air traffic control personnel transmitting instructions to the pilot by radio. The approach may be conducted with surveillance radar (ASR), Category Code 133 75, only or with both surveillance and precision approach radar (PAR), Category Code 134 41.

13440-1.1 **Components.** A GCA system is part of a Class IIIA Air Traffic Control Facility (ATCF), see Basic Category 133. An ATCF is organized, manned, and equipped to provide air traffic control and low approach and landing services, including: air traffic sequencing to aircraft airborne within the airport traffic area; authority for aircraft to land or takeoff from runways, or heliports; control of aircraft and vehicles on the surface within the movement area; and control instructions to aircraft during the intermediate and final approach segments to ensure safe, orderly, and expeditious aircraft movement. Unless modified by letter of agreement, the air traffic control clearance authority vested in the control tower is limited to that permitted for operation in accordance with Visual Flight Rules (VFR), although Instrument Flight Rules (IFR) and special VFR air traffic control clearances, originated by other facilities having such authority, may be relayed or issued. Likewise, GCA control authority may be extended beyond the intermediate fix when authorized by letter of agreement (Class IIIB). Flight assistance services may also be provided. The GCA system is generic in terms of name; therefore, the two components should be identified separately by their respective Category Codes.

134 41 PRECISION APPROACH RADAR (PAR) (EA)

FAC: 1341

BFR Required: Y

Design Criteria: UFC 4-141-10N, Aviation Operation and Support Facilities

Planning Criteria: P-80.3, Airfield Safety Clearances (Facility Planning Factor Criteria for Navy and Marine Corps Shore Installations, Appendix E)

13441-1 **DEFINITION.** The Precision Approach Radar (PAR) is an unattended self-contained radar system. The PAR detects azimuth, elevation, and range information of aircraft on final landing approach to PAR instrumented runways. The information is displayed in the Military Terminal Radar Approach Control (MTRACON) Facility. The controller uses the information to direct the aircraft along the glide path to the visual

portion of an instrument approach. A PAR is a self-contained transportable unit mounted either on a turntable or on fixed base.

13441-2 **REQUIREMENTS.** A reinforced concrete platform is provided for fixed mounted PAR. Reinforced concrete foundations are provided to support the turntable mounted PAR frame.

134 42 PRECISION APPROACH LANDING SYSTEM (PALS) (EA)

FAC: 1341

BFR Required: Y

Design Criteria: UFC 4-141-10N, Aviation Operation and Support Facilities

Planning Criteria: P-80.3, Airfield Safety Clearances (Facility Planning Factor Criteria for Navy and Marine Corps Shore Installations, Appendix E)

13442-1 **DEFINITION.** The Precision Approach Landing System (PALS) is an unattended, self-contained radar system. The PALS detects azimuth, elevation, and range information of aircraft on final approach to PALS instrumented runways. This information is displayed in the Military Terminal Radar Approach Control (MTRACON) Facility. The controller uses the information to direct the aircraft along the glide path to the visual portion of an instrument approach.

13442-2 **REQUIREMENTS.** Reinforced concrete foundations are required for the PALS antenna tower.

134 43 INSTRUMENT LANDING SYSTEM (ILS) (EA)

FAC: 1341

BFR Required: Y

Design Criteria: UFC 4-141-10N, Aviation Operation and Support Facilities

Planning Criteria: P-80.3, Airfield Safety Clearances (Facility Planning Factor Criteria for Navy and Marine Corps Shore Installations, Appendix E)

13443-1 **DEFINITION.** The Instrument Landing System (ILS) provides azimuth, distance, elevation, and glide path position to aircraft on a precision approach to the ILS instrumented runway. The ILS operates in the VHF and UHF radio bands.

13443-2 **REQUIREMENTS.** The ILS consists of two stations, a localizer and antenna station, and a glide slope equipment station. The localizer station requires a 5.49 meter by 6.1 meter (18 foot by 20 foot) concrete pad for the building housing the localizer equipment and a 3.66 meter by 5.49 meter (12 foot by 18 foot) concrete pad for the glide slope equipment building.

13443-3 **SITE PLANNING.** Both stations are located near the ends of the runway and require access roads and a pull-off area for maintenance personnel.

134 44 MICROWAVE LANDING SYSTEM (MLS) (EA)**FAC: 1341****BFR Required: Y****Design Criteria:** UFC 4-141-10N, Aviation Operation and Support Facilities**Planning Criteria:** P-80.3, Airfield Safety Clearances (Facility Planning Factor Criteria for Navy and Marine Corps Shore Installations, Appendix E)

13444-1 **DEFINITION.** The Microwave Landing System (MLS) provides azimuth, distance, elevation, and glide path position to aircraft on a precision approach to the MLS instrumented runway. The MLS operates in a narrow band microwave frequency.

13444-2 **REQUIREMENTS.** The MLS consists of two stations, an azimuth station and an elevation station. Each station requires a concrete foundation pad for the respective types of equipment. The azimuth station requires a 1.52 meter by 6.1 meter (5 foot by 20 foot) pad and the elevation station requires a 1.21 meter by 1.83 meter (4 foot by 6 foot) pad for the instrumentation device.

13444-3 **SITE PLANNING.** Both stations are located near the ends of the runway and require access roads and a pull-off area for maintenance personnel.

134 45 SHORE BASED AUTOMATIC CARRIER LANDING SYSTEM (ACLS) (EA)**FAC: 1341****BFR Required: Y****Design Criteria:** None Available**Planning Criteria:** P-80.3, Airfield Safety Clearances (Facility Planning Factor Criteria for Navy and Marine Corps Shore Installations, Appendix E)

13445-1 **DEFINITION.** The Shore-based Automatic Carrier Landing System (ACLS) is an unattended, self-contained radar system. The ACLS consists of precision tracking radar coupled to a computer data link to provide continuous information to the aircraft, monitoring capability to the pilot, and a backup approach system. Four modes of approach are available, depending on aircraft equipment. In Mode 1 approaches, data-link-transmitted ACLS signals are coupled to the autopilot after ACLS radar lock-on and control the aircraft until touchdown. Mode 1A approaches differ from Mode 1 approaches in that data-link ACLS signals are uncoupled at ½ mile (approximately 61 meters (200 feet) altitude) from touchdown. Mode 2 approaches the pilot-controlled using data-link needles information displayed in the aircraft allowing the pilot to fly the aircraft to the minimums in effect. A Mode 3 approach is a controller talk-down approach using no special equipment on the aircraft.

13445-2 **REQUIREMENTS.** Reinforced concrete foundations are required for the Shore-based ACLS antenna tower.

134 50 OBSTRUCTION LIGHTING AND MARKINGS (EA)**FAC: 1341****BFR Required: N**

Design Criteria: NAVAIR 51-50AAA-2, Visual Landing Aids Design Standards, Land-based Installations

Planning Criteria: P-80.3, Airfield Safety Clearances (Facility Planning Factor Criteria for Navy and Marine Corps Shore Installations, Appendix E)

13450-1 **DEFINITION OF OBSTRUCTION.** An airfield obstruction is an object that extends above the air safety clearance surfaces established for the airfield. Any object that violates the clearance zone will be removed, if practical; reduced in height to below the hazard level; or marked as an obstruction. Standards for determining obstructions to air navigation have been established by U.S. Code and are published in Federal Aviation Regulations, Part 77, which covers "Objects Affecting Navigable Airspace."

13450-2 **OBSTRUCTION LIGHTING.** Obstruction lighting provides visual identification of objects at night, or in some cases in day times, that are potentially hazardous to air navigation.

13450-2.1 **Definition.** Obstruction lighting is a system of lights that define the vertical and horizontal limits of a hazard to aircraft operations. Hazardous conditions exist when any obstruction encroaches on the standard airfield clearance surfaces or an unsafe condition, such as construction, on the airfield exists. Obstruction lighting includes flashing beacons and steady burning lights, both of which are aviation red in color.

13450-2.2 **Requirements.** The configuration, type, and number of lights depend upon the height and type of obstruction to be identified and on its surroundings. For objects less than 45.7 meters (150 feet) in height only steady burning lights mounted at the top are used. For objects more than 45.7 meters (150 feet) in height a combination of one or more beacons and one or more levels of steady burning lights are used. For each required lighting level not less than one beacon or two lights will be visible at any azimuth angle and at all approach angles. Some obstructions may require several lights or beacons at each light level. Consult NAVAIR 51-50AAA-2 for additional lighting types that may be used.

In some instances, obstructions require higher intensity lighting to provide identification and adequate clearance of the object in restricted visibility, especially during daylight hours. These objects are typically tall antenna towers, transmission lines, and tall stacks or chimneys. It is recommended to use flashing higher intensity obstruction lighting systems that may be more effective and more economical to install and maintain where permitted. These lighting systems include: high intensity white obstruction lights; medium intensity obstruction lights; and dual red and higher intensity white lights. Consult NAVAIR 51-50AAA-2 for the necessary lighting type. It is necessary to provide lighting on all obstructions so that visibility of the lighting is assured from any normal angle of approach and from any direction.

13450-3 **OBSTRUCTION MARKINGS.** Obstruction markings provide visual identification of objects that are potentially hazardous to safe air navigation and to warn aircrews of their presence during daytime flight operations. The markings for different types of obstructions vary depending on the nature of the object and its location. The types of markings or markers used for obstructions include: painted markings; markers; and vehicle markings.

13450-3.1 **Painted Markings.** Painted markings are the most common form of obstruction marking. Most obstructions are marked by painting the surface. Obstruction marking colors are aviation orange and aviation white. Other colors sometimes used include yellow, black, red, and aluminum. Painted surfaces will change color with time by fading, cracking, and/or peeling. Repainting is a must. The size and shape of the obstruction determines the type of painting pattern used. Painting patterns include: solid patterns, alternate color bands, checkerboard patterns, and teardrop patterns. Consult NAVAIR 51-50AAA-2 for additional pattern information.

13450-3.2 **Markers.** Markers are used where it is impractical to mark an obstruction by painting. Markers may also be used in addition to painted markings if such markers may improve the conspicuity of the obstruction. These markers are displayed in conspicuous positions on or adjacent to the obstructions so as to retain the general definition of the obstruction. Markers should not increase the hazard that they mark. The two types of markers used include spherical markers and flag markers. Consult NAVAIR 51-50AAA-2 for marker usage.

13450-3.3 **Vehicle Markings.** Vehicle markings exist on vehicles used in the aircraft operational areas of the airfield and are marked according to NAVAIR 51-50AAA-2.

134 55 VISUAL APPROACH SLOPE INDICATOR (VASI) SYSTEM (EA)

FAC: 1341

BFR Required: N

Design Criteria: NAVAIR 51-50AAA-2, Visual Landing Aids Design Standards, Land-based Installations

Planning Criteria: P-80.3, Airfield Safety Clearances (Facility Planning Factor Criteria for Navy and Marine Corps Shore Installations, Appendix E)

13455-1 **DEFINITION.** The Visual Approach Slope Indicator (VASI) System is an unattended system that provides visual glide slope guidance to pilots of aircraft during the final landing approach. The VASI is helpful during day and night operations and for Visual Flight Rules (VFR) and Instrument Flight Rules (IFR) operations. These requirements apply only for existing VASI installations. For complete replacement use Precision Approach Path Indicator (PAPI) System, Category Code 134 56.

13455-2 **CONFIGURATIONS.** The VASI system consists of several light units arranged in two and three bars near the edges of the runway in the touchdown zone. Each light unit projects a beam, fan-shaped in azimuth and split vertically with a white

sector above and a red sector below. The light units are arranged in rows or bars on one or both sides of the runway. Each bar consists of two or three light units. If the bars are on both sides of the runway, the opposite bars shall be in the same line. The bar nearest the runway threshold is referred to as the downwind bar. The bar farthest from the threshold is the upwind bar. If the system has three bars, the bar between the others is the middle bar. A pilot making an approach and observing a two-bar VASI system will see one of the following configurations:

- On the established approach path angle, the downwind bar will be white and the upward bar will be red.
- Below the established approach path angle, both bars will be red.
- Above the established approach path angle, both bars will be white. In the transition sector where the light changes color, a narrow sector of the beam may appear to be pink. For a three-bar VASI system, which creates two approach path angles, the pilot uses the approach path angle established for his type of aircraft, and the third bar, although visible, is not part of the guidance system.

13455-3 **TYPES OF VASI SYSTEMS.** There are three types of VASI systems:

13455-3.1 **VASI-4 System.** This is a two-bar, four light unit system. There are two light units in each bar and are located only on one side, usually the left, of the runway. Some Navy airfields may have this system.

13455-3.2 **VASI-12 System.** This is a two-bar, twelve light unit system. There are three light units in each bar located on both sides of the runway. This is the system for joint use airfields with international civilian airline operations and some existing VASI installations at Navy airfields use this system.

13455-3.3 **VASI-16 System.** This is a three-bar, sixteen light unit system. There are three light units in each bar located on both sides of the runway for the downwind and middle bars and two lights on each side of the runway for the upwind bar. This system is used for airfields qualified for international civilian operations using large aircraft.

13455-4 **CRITERIA.** Conditions that may justify the requirement for a VASI installation are:

- The runway is used by aircraft with such characteristics that the approach angle must be maintained within close limits including speed and rate of descent.
- The runway is situation in an area where the pilots of some aircraft may have difficulty in judging the proper approach angle for any of the following reasons: 1) The approach is over water or featureless terrain that does not provide adequate visual cues; 2) Absence of

sufficient extraneous lights in the approach area at night; or 3) Visual information is misleading; e.g., deceptive terrain or sloping runways may cause false impressions.

- Objects in the approach area that may be a serious hazard if an aircraft descends below the normal approach path.
- Conditions at the runway ends may present special hazards to aircraft undershooting or overrunning the runway.
- Terrain or meteorological conditions create severe or unusual turbulence along the approach path.

All light units are elevated lights and shall be installed on stable concrete pads or bases. Each leg support of the unit shall be mounted on a frangible coupling.

13455-5 LOCATION OF VASI BARS. The preferred locations are 184 meters (600 feet) from threshold to the downwind bar and at 213 meter (700 foot) intervals for the other one or two bars. The Runway Reference Point (RRP) is normally located midway between the downwind and upwind bars of two-bar VASIs or downwind and middle bar of three-bar VASIs installations. VASI bars may be placed at other than preferred locations, but the downwind bar shall not be less than 152 meters (500 feet) or more the 244 meters (800 feet) from runway threshold. The other bar or bars shall not be less than 152 meters (500 feet) or more than 274 meters (900 feet) from the adjacent bar.

13455-6 LOCATION OF THE LIGHT UNITS. The centerline of the innermost light unit of each bar shall be not less than 15.2 meters (50 feet) and not more than 18.3 meters (60 feet) from the runway edge and not less than 22.9 meters (75 feet) from the edge of any other runway, taxiway, or apron area. The innermost light units of all bars of the system shall be the same distance from the runway edge. The light units for each bar shall be equally spaced at 4.88 meters (16 feet) on center starting from the innermost light units. The elevation of the horizontal apertures of the light units shall be within 0.31 meters (12 inches) of the crown of the runway, except in areas with deep snow accumulations. There the light unit may be installed with the apertures not to exceed 1.22 meters (48 inches) above the ground surface. For installations with light units on both sides of the runway, the elevations of the lights on opposite sides shall not differ by more than 0.31 meters (12 inches). The apertures of the light units in a bar may have a tolerance of 0.03 meters (1 inch) horizontally and vertically from the line of the bar.

134 56 PRECISION APPROACH PATH INDICATOR (PAPI) SYSTEM (EA)

FAC: 1341

BFR Required: Y

Design Criteria: NAVAIR 51-50AAA-2, Visual Landing Aids Design Standards, Land-based Installations

Planning Criteria: P-80.3, Airfield Safety Clearances (Facility Planning Factor Criteria for Navy and Marine Corps Shore Installations, Appendix E)

13456-1 **DEFINITION.** The Precision Approach Path Indicator (PAPI) System is an unattended system which provides visual glide slope guidance to pilots of aircraft during the final landing approach. The PAPI system provides this information during the day and night for Visual Flight Rules (VFR) and Instrument Flight Rules (IFR) operations as low as Category I conditions.

13456-2 **REQUIREMENTS.** The PAPI system consists of four light source units arranged in a wing bar near the edges of the runway in the touchdown area. Each light unit consists of two or more lamps and projects a beam of light, fan-shaped in azimuth and split vertically with a white sector above and a red sector below the transition zone. Each light unit is aimed at a slightly different elevation angle to present a different color pattern to a pilot on final approach depending on his/her position relative to the established approach slope. When observed from the ideal approach slope the two inboard light units are seen as red and the two outboard units as white. If more light units are red, the pilot is too low, and if more are white, he/she is too high. The lights also provide information on how much too high or too low the pilot is. The four light units are operated simultaneously whenever this runway approach is active.

13456-3 **CRITERIA.** Conditions that may justify the requirement for a VASI installation are:

- The runway is used by aircraft with such characteristics that the approach angle must be maintained within close limits including speed and rate of descent.
- The runway is situation in an area where the pilots of some aircraft may have difficulty in judging the proper approach angle for any of the following reasons: 1) The approach is over water or featureless terrain that does not provide adequate visual cues; 2) Absence of sufficient extraneous lights in the approach area at night; or 3) Visual information is misleading; e.g., deceptive terrain or sloping runways may cause false impressions.
- Objects in the approach area that may be a serious hazard if an aircraft descends below the normal approach path.
- Conditions at the runway ends may present special hazards to aircraft undershooting or overrunning the runway.
- Terrain or meteorological conditions create severe or unusual turbulence along the approach path.
- The runway length is short and there is serious danger of overrun if the touchdown is long.

All light units shall be installed on stable concrete bases and mounted on a frangible coupling.

13456-4 **LOCATION OF PAPI SYSTEM.** The wing bar shall be in a horizontal line at 90 +/-1 degrees to the runway centerline and should be on the left hand side of the runway as observed from the approach zone. To avoid intersecting runways or taxiways or other major installation problems, the PAPI may be located on the right side of the runway. The individual light units shall not be more than 0.08 meters (3 inches) longitudinally or in elevation from the line for the wing bar. The elevation of the line of the wing bar at the exit lenses or windows should be not more with 15.2 meters (50 feet) preferred. The other units shall be equally spaced at 9.2 +/- 0.6 meters (30 +/-2 feet). The preferred distance of the wing bar upwind from the runway threshold should be 305 +/- 30.5 meters (1,000 +/-100 feet). The actual location of this wing bar may be affected by the following conditions:

- The preferred distance of the wing bar shall be such as to have the visual approach slope coincide with the established glide path angle of the Precision Approach Radar (PAR), the Instrument Landing System (ILS), or other precision electronic approach aid.
- No light source unit shall be less than 22.9 meters (75 feet) from the edge of any other runway or any taxiway.
- The preferred distance of the wing bar shall ensure the minimum wheel clearance at threshold, usually 9.2 meters (30 feet), of the most critical aircraft normally using the runway or of obstacle clearance when the pilot is at or above the transition sector from red to white for the light source unit with lowest vertical aiming angle.
- The preferred distance of the wing bar shall be adjusted to compensate for the differences in elevation between the light exit windows and the runway threshold for sloping runways or for extra high installations to clear snow accumulations.
- The preferred distance of the wing bar shall provide adequate landing distance for stopping the most critical aircraft using this approach.

134 60 OPTICAL LANDING AIDS (EA)

FAC: 1341

BFR Required: N

Design Criteria: NAVAIR 51-50AAA-2, Visual Landing Aids Design Standards, Land-based Installations

Planning Criteria: P-80.3, Airfield Safety Clearances (Facility Planning Factor Criteria for Navy and Marine Corps Shore Installations, Appendix E)

13460-1 **DEFINITION.** Optical Landing Aids (OLA) provides the pilot approaching for a landing with a visual signal to assist in intercepting and maintaining the correct approach glide slope. The OLA is a required visual aid for landings on aircraft carriers, but on shore-based airfields the OLA is primarily an aid for training or practice. The OLA may be used during day or night operations and in all weather conditions.

13460-2 **REQUIREMENTS.** The OLA systems are located near the touchdown point on the runway and consist of the following lighting components:

13460-2.1 **Source Lights.** The source lights are a yellow line of lights or images often referred to as the “meatball”. Some systems present a red signal when the aircraft is too low. The source lights may be formed by reflections in a special mirror or a vertical stack of lens cells or closely spaced lights.

13460-2.2 **Datum Lights.** The datum lights are a horizontal bar of green lights that provide a visual reference for determining the aircraft’s position in relation to the ideal approach glide path. The datum lights bar is in two groups of lights with a group on each side of the source lights. The visual signals presented to a pilot making an approach for landing are the same as his/her position relative to the glide slope path. If the source light appears to be above the datum lights he/she is too high, or if the source light appears to be below the datum lights he/she is too low and should adjust his/her approach path angle to obtain the correct on glide path signal with the source light in line with the datum lights.

13460-2.3 **Wave-off Lights.** The wave-off lights are flashing red lights along each side of the source lights. The wave-off lights are activated only to inform the pilot that he must execute a missed approach procedure.

13460-2.4 **Cut Lights.** Some optical landing systems have flashing green lights located above the source lights which are activated to instruct the pilot of propeller-driven aircraft to cut engine power.

13460-2.5 **Mounting Pad.** The height of the mounting pad shall be at ground level to preclude the creation of an obstruction when the OLA system is relocated from the site. During the calibration process the optimum height of the OLA system can be achieved by placing blocks under the equipment trailer cart and/or the addition of load leveling jacks to the cart.

13460-3 **TYPES OF OLA SYSTEMS.** There are four types of OLA Systems. The FLOLS, MOLS and IFLOLS are fixed signal systems that automatically indicate to the pilot his/her position in relation to the established glide path. The MOVLAS is a temporary replacement system for which the LSO controls the position of the source (“meatball”) light. The specifications for each of these systems are listed below.

13460-3.1 **Fresnel Lens Optical Landing System (FLOLS).** The FLOLS consists of five yellow source light cell assemblies arranged vertically, 12 green datum lights, 10 red wave-off lights, and some models have 4 green cut lights. The stack of lens cells are all lighted but usually only one cell is visible to the pilot. The relation of this cell to the datum lights indicates the pilot’s position relative to the proper glide slope. These lights are trailer-mounted for portability to move from one site to another.

13460-3.2 **Mirror Optical Landing System (MOLS).** The MOLS consists of a special mirror, 8 yellow source lights, 12 green datum lights, 10 red wave-off lights,

and may have two green cut lights and double obstruction lights. The mirror reflects the image of the source lights to provide the “meatball”. The position of the “meatball” in relation to the line of datum lights indicates the pilot’s position relative to the proper glide slope.

13460-3.3 **Manually Operated Visual Landing Aid System (MOVLAS).** The MOVLAS is an emergency system to be used when the FLOLS or MOLS is inoperable. The MOVLAS source light is operated by the Landing Signal Officer (LSO) using a special controller. The source lights are 23 lights arranged in two closely spaced vertical rows. The six lowest lights are red and the other 17 are yellow. Three lights at adjacent heights are operated to form the source lights. As the controller handle is moved upward, the source lights are switched on progressively towards the top in clusters of three. This gives an approaching pilot the signal to increase his elevation as directed by the LSO. The LSO therefore guides the pilot by signaling to raise or lower his/her altitude to achieve the proper glide slope. The MOVLAS is provided with 10 green datum lights, 8 red wave-off lights, and 2 green cut lights.

13460-3.4 **Improved Fresnel Lens Optical Landing System (IFLOLS).** The land-based MK 14 MOD 0 IFLOLS is the replacement system for the FLOLS MK 8 MOD 0 and MK 8 MOD 1 land-based systems. The IFLOLS consists of 12 cells which provide greater sensitivity and resolution to the light in the cell seen by the pilot (“meatball”) than the FLOLS. The position of the “meatball” relative to the datum lights indicates to the pilot where he/she is relative to proper glide slope. The IFLOLS system also has greater acquisition distance than the FLOLS. The land-based IFLOLS is also trailer-mounted for easy portability.

13460-4 **CRITERIA FOR JUSTIFYING OLA EQUIPMENT.** Each runway landing area with or programmed for a simulated carrier deck lighting installation shall be provided with a site installation and OLA equipment. Most OLA systems are portable and may be moved to different sites as the approach runway is changed. The use of OLA is intended for runway ends with simulated carrier deck lighting. Airfields without simulated carrier deck lights may have a need for proficiency that justifies the installation of OLA sites and equipment.

13460-5 **LOCATION OF OLA EQUIPMENT.** The OLA site shall be located on the left hand side of the runway as viewed by the approaching pilots. If the OLA is associated with a simulated carrier deck installation, the face of the lens cells or mirror shall be located 131.1 meters (430 feet) forward of the ramp athwartship lights. If the OLA is an independent installation for a three degree glide slope, the preferred location of the face of the lens cells or mirror is 228.7 +/- 3.05 meters (750 +/-10 feet) forward of the runway threshold but may be influenced by the following factors:

- The glide path angle for the primary electronic approach system.
- Special threshold crossing height requirements.
- Special ground point intercept for the runway or instrument approach system.

- Approach zone obstruction clearance requirements.
- Intersecting runways or taxiways.

The mounting pad shall be located so that the centerline of the lens cells is not less than 35.1 meters (115 feet) from the runway centerline and not less than 3.05 meters (10 feet) from the runway edge. To preclude the mounting pad from becoming an airfield obstruction when the OLA is relocated, the height of the pad should be no higher than 0.05 – 0.08 meters (2-3 inches) above terrain level (almost at ground level). The required height of the OLA should then be achieved by the use of concrete blocks on the pad and/or jacking screws attached to the OLA. The mounting pad shall be 3.4 meters x 5.2 meters (11 feet x 17 feet), level, and have a permanent survey marker for correct location and alignment of the centerline of the FLOLS cells. At 45.7 meters (150 feet) toward the runway threshold from the position for the face of the cells on a line parallel to the runway centerline, a survey monument for the siting mirror station for the FLOLS shall be installed. This monument or pad shall have a permanent survey marker for correct location of this equipment and should be at the same elevation as the mounting pad.

NOTE: Any new OLA pads installed at simulated carrier deck lighting installations or proficiency installations shall be made to accommodate an IFLOLS configuration. Pad size 3.4 meters x 5.2 meters (11 feet x 17 feet), perpendicular to the simulated carrier deck centerline, with an elevation at terrain level.

134 62 WIND DIRECTION INDICATOR (EA)

FAC: 1341

BFR Required: N

Design Criteria: NAVAIR 51-50AAA-2, Visual Landing Aids Design Standards, Land-based Installations

Planning Criteria: P-80.3, Airfield Safety Clearances (Facility Planning Factor Criteria for Navy and Marine Corps Shore Installations, Appendix E)

13462-1 **DEFINITION.** A Wind Direction Indicator provides visual information of the surface wind direction and general indication of the wind speed to the aircrew. This wind information is most useful during takeoff, for orientation to make an approach, and in the final phase of approach prior to touchdown.

Wind cones/socks are the most common type of wind direction indicators; however, wind tees do still exist and remain in this Category Code for inventory purposes. The "wind tee" is a "T" shaped rotating structure used at Navy and Marine Corps air installations as a navigational aid. It is positioned on the ground where it will be visible from all directions of approach and centrally located for identification and orientation from the air. The "wind tee" is outlined with green lights which, when lit, give it the appearance of a single green "T" when viewed from above. When the lights are not lit, it appears as a single stroke yellow "T". A background of crushed stone, gravel, or similar material that will retard the growth of vegetation and provide sharp contrast to the "wind tee" colors is provided.

13462-2 **REQUIREMENTS.** The standard wind direction indicator used on Navy and Marine Corps airfields is the 3.66 meter (12 foot) wind cone and is often called a wind sock. This wind cone is a fabric, truncated cone 3.66 meters (12 feet) long. The throat, or entrance for air into the cone is 0.91 meters (3 feet) in diameter to fit over the framework 1.37 meters (54 inches) long to hold the cone open. The color of the cone is orange or white and provides good contrast with its background when viewed from an altitude of 305 meters (1,000 feet). The support for the wind vane and illumination and obstruction lights, if used, is pivoted for lowering the cone and lights for maintenance. If the airfield or runways have lighted facilities for flight operations at night, the cone must be illuminated.

A 2.44 meter (8 foot) wind cone can be used for smaller, secondary airfields, heliports, or if necessary to locate the wind indicator closer than the standard runway. These wind cones are proportionately smaller than the larger size, be in contrast to their surroundings, have the same maintenance issues, and must be illuminated at night for visibility.

13462-3 **SITE PLANNING.** The location of the 3.66 meter (12 foot) wind cone is near the runway threshold not less than 122 meters (400 feet) from the centerline, preferably between 152 meters (500 feet) and 457 meters (1,500 feet) down the runway from the threshold. One wind cone may serve the ends of two runways if the distance from either runway centerline is not more than 305 meters (1,000 feet).

The location of the 2.44 meter (8 foot) wind cone is not less than 45.7 meters (150 feet) from the runway edge where clearance space or wind disturbances are not suitable for the 3.66 meter (12 foot) wind cone. If the wind cone is less than 91.4 meters (300 feet) from the runway edge, the support shall be low-mass or light-weight type.

134 64 RUNWAY DISTANCE MARKERS (EA)

FAC: 1341

BFR Required: N

Design Criteria: NAVAIR 51-50AAA-2, Visual Landing Aids Design Standards, Landbased Installations

Planning Criteria: P-80.3, Airfield Safety Clearances (Facility Planning Factor Criteria for Navy and Marine Corps Shore Installations, Appendix E)

13464-1 **DEFINITION.** The purpose of Runway Distance Markers (RDMs) is to indicate to aircrews the distance remaining to the end of the runway during takeoff and landing. The RDM provide this information for day and night operations in all weather conditions. The RDM should be provided for all runways where fixed wing jet aircraft operations are conducted and are recommended for runways intended for operations of propeller type aircraft. If the runway is used for nighttime or low visibility Instrument Flight Rule (IFR) operations, the RDM must be internally illuminated. If the runway is only used for daytime operations, the RDM may have unlighted markers.

13464-2 **REQUIREMENTS.** The RDM consists of a row of vertical markers (signs) spaced along each side of the runway longitudinally. The faces of the markers are vertical. Each face of the marker indicates the distance in thousands of feet remaining to each end of the runway. The color scheme used is white numerals on a black background.

13464-3 **SITE PLANNING.** The rows of RDM are parallel to and equidistant from the runway centerline. A pair of markers on opposite sides of the runway is located at each 305 meter (1,000 foot) spacing. The lines connecting the pairs of markers are perpendicular to the runway centerline. The apex or edges of the markers nearest the runway in each row shall form a line not less than 15.2 meters (50 feet) and not more than 22.9 meters (75 feet) from the full strength runway edge. The 22.9 meter (75 foot) distance is preferred. The marker cannot be less than 15.2 meters (50 feet) from the edge of any intersecting runway or taxiway. Where the 305 meter (1,000 foot) positions do not provide clearance from an intersecting runway or taxiway, the position of the pair of markers may be moved a maximum of 30.5 meters (100 feet) to obtain the clearance.

For runways that are not exact multiples of 305 meters (1,000 feet), the extra distance is apportioned at the runway ends by the following equation:

$$E = (D - M)/2$$

E = the excess distance in feet to be added to the intervals at the runway ends.

D = the length of the runway in feet.

M = the distance in feet of the maximum number of 305 meter (1,000 foot) intervals.

Consult NAVAIR 51-50AAA-2 for additional information of marker siting and special site conditions. The markers are internally illuminated. Runway distance markers are planned for all Navy and Marine Corps installation.

134 66 VOR/TACAN CHECK SIGN (EA)

FAC: 1341

BFR Required: N

Design Criteria: NAVAIR 51-50AAA-2, Visual Landing Aids Design Standards, Land-based Installations

Planning Criteria: P-80.3, Airfield Safety Clearances (Facility Planning Factor Criteria for Navy and Marine Corps Shore Installations, Appendix E)

13466-1 **DEFINITION.** A VOR/TACAN Check Sign provides information for the pilot when verifying the operation of the navigational aid in the aircraft before taking off. This check sign is a visual identification marker erected in the area adjacent to the aircraft holding point at the taxiway access to runway ends. The sign includes the type of navigational aid, identification code, radio channel, magnetic bearing, and the distance in nautical miles to the transmitting antenna from the checkpoint marking. It provides aircrew members with operational check information on the navigation equipment of the aircraft.

13466-2 **REQUIREMENTS.** The character height shall not be less than 0.18 meters (7 inches) or more than 0.20 meters (8 inches) high and the stroke width of not less than 0.03 meters (1 inch). The sign should have black characters on a yellow background and be similar in shape and color when lighted at night and unlighted during the daytime.

13466-3 **SITE PLANNING.** Check signs are planned for all runway ends at each air installation equipped with a tactical air navigation (TACAN), visual omni-directional range (VOR), or combined (VORTAC) installation.

134 70 RADAR TOWER (EA)

FAC: 1341

BFR Required: N

Design Criteria: None Available.

Planning Criteria: P-80.3, Airfield Safety Clearances (Facility Planning Factor Criteria for Navy and Marine Corps Shore Installations, Appendix E)

13470-1 **REQUIREMENT.** Radar towers must be planned on an individual basis.

134 71 AVIATION METEOROLOGICAL FACILITY (EA)

FAC: 1341

BFR Required: Y

13471-1 **DEFINITION.** An AVI meteorological facility is a weather forecasting facility that supports air operations.

13471-2 **GENERAL.** . An engineering analysis is required to determine facility space allocations.

135 COMMUNICATION LINES

135 10 COMMUNICATION LINES OTHER THAN TELEPHONE (MI)

FAC: 1351

BFR Required: N

13510-1 Communication lines provide circuits between the various activities on or off the station. The communications net may include trunk line service cable, feeder lines, and direct circuits depending on the complexity of the system.

**135 11 FIBER OPTIC COMMUNICATIONS LINES, UNDERGROUND
IN CONDUIT (MI)**

FAC: 1351

BFR Required: N

13511-1 **DEFINITION.** The communications lines are non-armored OM-2 Singlemode Fiber Optic cables installed inside an underground duct.

**135 12 FIBER OPTIC COMMUNICATIONS LINES, NON-CONDUCTIVE RISER
RATED (EA)**

FAC: 1351

BFR Required: N

13512-1 **DEFINITION.** The communications lines are non-armored OM-3 multimode Fiber Optic cables installed inside and underground duct.

**135 13 FIBER OPTIC COMMUNICATIONS LINES, OUTSIDE PLANT,
ARMORED (MI)**

FAC: 1351

BFR Required: N

13513-1 **DEFINITION.** These communications lines are singlemode or multimode or mixed mode fiber rated for indoor and outdoor use for campus and/or building backbone installed in riser, conduit, and ducts or direct buried.

135 15 OPTICAL GROUND WIRE (MI)

FAC: 1351

BFR Required: N

13515-1 **DEFINITION.** Optical ground wire is for electrical power and optical communication between power substations in support of relay interconnects.

135 20 TELEPHONE LINES (MI)

FAC: 1351

BFR Required: N

13520-1 No specific criteria are available.

**135 21 FIBER OPTIC COMMUNICATIONS LINES, OUTSIDE PLANT, MARINIZED
(UNDERWATER/WETLAND) (MI)**

FAC: 1351

BFR Required: N

13521-1 **DEFINITION.** The communication lines are underwater grade reinforced composite fiber cable used in aquatic conditions.

135 31 COPPER COMMUNICATIONS LINES, OUTSIDE PLANT, GEL FILLED (MI)

FAC: 1351

BFR Required: N

13531-1 **DEFINITION.** These types of communications lines are for indoor and outdoor use for campus and/or building backbone copper cable installed in riser, conduit, and ducts or direct buried.

135 32 COPPER COMMUNICATIONS LINES, OUTSIDE PLANT, AIR CORE (MI)

FAC: 1351

BFR Required: N

13532-1 **DEFINITION.** These types of communications lines are annealed reinforced composite copper cable used with air compressors to support continual drying.

135 33 COPPER COMMUNICATIONS LINES, OUTSIDE PLANT, MARINIZED (UNDERWATER/WETLAND) (MI)

FAC: 1351

BFR Required: N

13533-1 **DEFINITION.** These types of communications lines are underwater grade reinforced composite copper cable used in aquatic conditions.

135 34 COPPER COMMUNICATIONS LINES, OUTSIDE PLANT, ARMORED (MI)

FAC: 1351

BFR Required: N

13534-1 **DEFINITION.** These communications lines are bulk copper cable designed for direct burial condition installed directly in or above ground without conduit.

136 AIRFIELD PAVEMENT LIGHTING

136-1 **DEFINITION.** Airfield pavement lighting includes facilities for lighting all airfield pavements and approaches thereto. The purpose of this section is to provide the general requirements for airfield Visual Landing Aids for approaches, landings, takeoffs, taxiing, and surface maneuvering of aircraft on Navy and Marine Corps airfields. The visual landing aids include lighting and markings. The various lighting systems are planned with regard to other airfield related facilities so that integrated control is

achieved and the resultant overall lighting system is compatible with the operational mission of the air installation.

136-2 **CONDITIONS.** Based on missions assigned by CNO, lighting facilities are developed to meet Visual Flight Rules (VFR) or Instrument Flight Rules (IFR) conditions as defined in NAVAIR 51-50AAA-2 as follows:

136-2.1 **Visual Flight Rules (VFR).** These are rules which govern the procedures for conducting flights under visual conditions. The minimum conditions in which VFR operations are permitted is a minimum cloud ceiling height of 304.8 meters (1,000 feet) and ground visibility of 4.83 km (3 miles).

136-2.2 **Instrument Flight Rules (IFR).** These are rules governing procedures for conducting instrument flight. IFR flight operations are dependent upon pilots' use of instrument guidance. As a ceiling becomes lower or the visibility more restrictive, the more precise the electronic and visual guidance must be as required for the following categories:

- (1) Non-precision IFR: IFR operations that use non-precision electronic aids (TACAN, VORTAC, etc.) to provide directional guidance for straight-in approaches to a Minimum Descent Altitude (MDA) as low as 79.2 meters (260 feet) and 1.61 km (1 mile) visibility or 1,250 meters (5,000 feet) Runway Visual Range (RVR).
- (2) Precision IFR, Category I: Requires precision electronic aids (ILS, PAR, or MLS) and visual aids for approach minimums of 60.9 meters (200 feet) Decision Height (DH) and 732 meters (2,400 feet) (some cases 488 meters (1,600 feet)) RVR.
- (3) Precision IFR, Category II: Requires precision electronic aids (precision ILS or MLS) and visual aids for approach minimums of 30.5 meters (100 feet) DH and 366 meters (1,200 feet) RVR.
- (4) Precision IFR, Category IIIA: Requires precision electronic aids (precision ILS or MLS) and visual aids for approach minimums of 0 meters (0 feet) DH and 213 meters (700 feet) RVR.
- (5) Precision IFR, Category IIIB: Requires precision electronic aids (precision ILS or MLS) and visual aids for approach minimums of 0 meters (0 feet) DH and 45.7 meters (150 feet) RVR.
- (6) Precision IFR, Category IIIC: Requires precision electronic aids (precision ILS or MLS) and visual aids for approach minimums of 0 meters (0 feet) DH and 0 meters (0 feet) RVR.

136-3 **REQUIREMENTS.** The types of approach visual aids required for an airfield depend on the kind of flight operations that will be performed. Flight operations are separated into VFR and IFR. Major airfields usually have both types of operations.

136-3.1 **Approach Visual Aids.** Approach visual aids associated with the different flight rules are indicated in Table 136-1.

Table 136-1. Approach Visual Aids Requirements

Visual Aids System		Authorized Operations						
		VFR	IFR Category					
			Non-Prec	I	II	IIIA	IIIB	IIIC
136-10	ALSF-1	NR	NR	R	NR	NR	NR	NR
136-10	ALSF-2	NR	NR	NR	R	R	R	R
136-10	MALSR	RS	RS	-	-	-	-	-
136-10	SALS	NR	RS	NR	NR	NR	NR	NR
136-30	Circling Guidance Lights	RS	RS	NR	NR	NR	NR	NR
136-60	REIL	C	C	-	NR	NR	NR	NR

C = Recommended
 R = Required. These visual aids are required for operating in the IFR Category, but other factors may negate approval for installation.
 RS = Required under special conditions.
 NR = Not required.

136-3.2 **Runway Approach Visual Aids.** The runway visual aids consist of markings and lighting installed near the runway. The runway lights include basic edge lights, low-intensity runway lights, and supplemental runway lights. The basic runway lights define the limits of the runway surface. These are edge lights, threshold lights, and runway end lights. Some runways may have displaced threshold lights and markings. The low-visibility runway lights are the centerline and touchdown zone lights. The supplemental runway lights may be runway exit lights, runway distance markers, and arresting gear markers. The configuration of the markings differs for the class of runway. The marking and types of lights may be different for runways on the same airfield. Runway visual aids associated with different flight rules are shown in Table 136-2.

Table 136-2. Runway Approach Visual Aids Requirements

Visual Aids System		Authorized Operations						
		VFR	IFR Category					
			Non-Prec	I	II	IIIA	IIIB	IIIC
	Runway Markings	R	R	R	R	R	R	IN
136-30	Runway Edge Lights (HIRL)	R	R	R	R	R	R	IN
136-30	Runway Edge Lights	R	R	R	R	R	R	IN
136-35	Runway Centerline Lights	NR	C	C	R	R	R	IN
136-55	Touchdown Zone Lights (TDZL)	NR	NR	OPT	R	R	R	IN
136-60	Displaced Threshold Lights and Markings	RS	RS	RS	RS	RS	RS	IN
136-60	Runway Threshold Lights and Markings	R	R	R	R	R	R	IN
<p>C = Recommended</p> <p>R = Required. These visual aids are required for operating in the IFR Category, but other factors may negate approval for installation.</p> <p>RS = Required under special conditions.</p> <p>OPT = Option as recommended by Air Station Commander and approved by NAVAIRSYSCOM.</p> <p>IN = Installation necessary.</p> <p>NR = Not required.</p>								

136-3.3 Taxiway Visual Aids. The taxiway lights and markings identify the area as a taxiway, define its limits, and provide directional guidance for maneuvering aircraft. The signs provide information on routes to taxi destinations and identify areas along the taxi route. Taxiway markings are painted on the paved surfaces and include centerline, edge, holding position, and checkpoint markings. The taxiway lights include either edge lights, centerline lights, or a combination of both lights, and

in some cases holding position lights. Taxiway guidance signs provide mandatory information that the pilot must recognize because of the existence of potential hazards. Also, general information is provided that assists the pilot in proceeding along the proper taxi route. Special signs may provide checkpoint information or routing information at complex intersections. The locations, types, and information on the signs vary for each taxiway. Taxiway visual aids associated with different flight rules are shown in Table 136-3.

Table 136-3. Taxiway Visual Aids Requirements

Visual Aids System	Authorized Operations						
	VFR	IFR Category					
		Non-Prec	I	II	IIIA	IIIB	IIIC
Taxiway Markings	R	R	R	R	R	R	R
Taxiway Edge Lights	R	R	R	R	C	C	C
Taxiway Centerline Lights, Intersections	NR	OPT	C	C	R	R	R
Taxiway Centerline Lights, Continuous	NR	NR	OPT	C	R	R	R
Taxiway Guidance Signs	RS	C	R	R	R	R	R
Special Signs (TACAN)	RS	RS	RS	RS	RS	RS	RS
Special Signs, Billboards	RS	RS	RS	RS	RS	RS	RS
Holding Position Signs	C	R	R	R	R	R	R
Holding Position Lights	RS	RS	RS	RS	RS	RS	RS
Taxiway Lights for Runways Used as Taxiways	RS	RS	RS	RS	RS	RS	RS
C = Recommended R = Required. RS = Required under special conditions. OPT = Option as recommended by Air Station Commander and approved by NAVAIRSYSCOM. NR = Not required.							

136-3.4 Special Considerations. The following airfield lighting requirements are determined by individual airfield needs as described under the referenced Category Code:

Approach Lighting	136 10
Apron and Parking Area Lighting and Markings	136 20
Runway Edge Lighting and Markings and Circling Guidance Lights	136 30
Runway Centerline Lighting and Markings	136 35
Simulated Carrier Deck Lighting and Markings	136 36
Wheels-Up/Wave-Off Lighting	136 45
Taxiway Lighting and Markings	136 50
Touchdown Zone Lighting and Markings	136 55
Threshold Lighting and Markings	136 60
Heliport Lighting and Marking Systems	136 65

Obstruction lighting, beacons, and other visual navigation and traffic aids are discussed under basic Category Code series 134. For airfield perimeter lighting, street lighting, and other general illumination, see Basic Category Code series 812, Electric Power – Transmission and Distribution Lines.

136 10 APPROACH LIGHTING (M/LF)

FAC: 1361

BFR Required: N

Design Criteria: NAVAIR 51-50AAA-2, Visual Landing Aids Design Standards, Land-based Installations

Planning Criteria: P-80.3, Airfield Safety Clearances (Facility Planning Factor Criteria for Navy and Marine Corps Shore Installations, Appendix E)

13610-1 **DEFINITION.** Approach lighting enhances the aircrew's ability to acquire the runway environment visually when making an approach for landing during periods of reduced visibility. Visual cues for directional and roll guidance are provided to the aircrew for operations at night and in marginal weather conditions by day. The system includes both approach lights and sequenced flashers.

Approach lighting is provided for primary instrument approach runways. Planning of Category I, Category II, or Category III approach lighting systems is accomplished in accordance with mission requirements as listed in Basic Category 136. With sufficient justification approach lighting may also be authorized for other runways.

13610-2 **CONSIDERATIONS.** Factors to be considered in the justification of any approach lighting system include, but are not limited to:

- Existing and desired precision approach minimums.
- Number of actual instrument approaches.
- Climatology.
- Surface features, obstructions and feasibility of construction.

13610-3 **REQUIREMENTS.** Approach lights fall into three categories:

13610-3.1 **High Intensity Approach Lighting System (ALSF-1).** The High Intensity Approach Lighting System, ALSF-1, is a system of light bars and barrettes in the approach zone immediately ahead of the runway threshold. The standard length of an ALSF-1 is 914 meters (3,000 feet) unless terrain or other local conditions prevent a full length installation. Then the length may be shortened to not less than 732 meters (2,400 feet). This shorter system can impact landing minimums. Approval from NAVAIRSYSCOM is required for systems shorter than 914 meters (3,000 feet). Systems that are between 427 meters (1,400 feet) and 701 meters (2,300 feet) are called Short Approach Lighting Systems (SALS). The ALSF-1 consists of centerline lighting barrettes, sequencing flashing lights, 305 meters (1,000 foot) crossbar, terminating bar, pre-threshold wing bars, and threshold lights (Category Code 136 60). The standard system extends from the threshold 914 meters (3,000 feet) into the approach area of the runway. A barrette is three or more lights closely spaced in a transverse line so that from a distance they appear as a single short illuminating bar. For the ALSF-1, the length of the barrette shall not exceed 4.57 meters (15 feet) and the center-to-center spacing of the lights shall not exceed 1.52 meter (5 feet).

13610-3.2 **High Intensity Approach Lighting System (ALSF-2).** The High Intensity Approach Lighting System, ALSF-2, is a system of light bars and barrettes in the approach zone immediately ahead of the runway threshold. This approach lighting system is intended for use where operation during Category II instrument flight conditions or lower weather minimums are required. The standard length of an ALSF-2 is 914 meters (3,000 feet) unless terrain or other local conditions prevent a full length installation. Then the length may be shortened to not less than 732 meters (2,400 feet). The plan for the ALSF-2 consists of centerline lighting barrettes, sequencing flashing lights, 305 meters (1,000 foot) crossbar, 152 meter (500 foot) crossbar, side row barrettes, and threshold lights (Category Code 136 60). A barrette is three or more lights closely spaced in a transverse line so that from a distance they appear as a short illuminating bar. For the ALSF-2, the length of the barrette shall not exceed 4.57 meters (15 feet) and the center-to-center spacing of the lights shall not exceed 1.52 meter (5 feet).

13610-3.3 **Medium Intensity Approach Lights (MALSR).** The MALSR is a medium intensity approach lighting system with runway alignment indicator lights. It is intended for installation at Naval airfields only in support of Visual Flight Rules (VFR) or non-precision instrument approaches where installation costs are a factor. The standard system consists of centerline lights, a 305 meters (1,000 foot) crossbar, and sequenced flashing lights. The centerline is coincident with the extended runway centerline. The overall system is 732 meters (2,400 feet) long, but may be shortened to as little as 427 meters (1,400 feet) where space or construction problems arise. Where systems are shortened to less than 610 meters (2,000 feet), flashers will be added to steady burning light stations to provide a minimum of three flashing lights.

136 20 APRON AND PARKING AREA LIGHTING AND MARKINGS (M/LF)**FAC: 1361****BFR Required: N**

Design Criteria: NAVAIR 51-50AAA-2, Visual Landing Aids Design Standards, Land-based Installations

Planning Criteria: P-80.3, Airfield Safety Clearances (Facility Planning Factor Criteria for Navy and Marine Corps Shore Installations, Appendix E)

13620-1 **DEFINITION.** Apron and parking area lighting enables the aircrew to guide their aircraft into position for loading, servicing, or parking and provides illumination to perform such functions as fueling, maintenance, loading, unloading, and security.

13620-2 **APRON MARKINGS.** Apron markings are the basic visual aid for taxiing in the apron area during daylight and to supplement the lights during night operations and for all meteorological conditions. The markings provide visual cues to aircrews for taxiing through a complex or congested area between the end of the taxiway and the final position for parking the aircraft. This area includes terminals, hangars, service areas, and taxiways. The apron markings include taxiway centerline and edge markings, shoulder or deceptive area markings for paved areas not intended for aircraft traffic, parking area markings, and special markings to identify destinations or to provide specific information.

13620-3 **APRON LIGHTING.** Lighting of apron and parking areas is accomplished by a combination of high and surface mounted floodlights and roadway luminaries. Apron and parking area lighting is provided at all air installations where night or all weather operations are conducted. The overall lighting scheme is developed after a study of the functions to be performed and the physical layout of pavements and structures of the particular airfield.

136 30 RUNWAY EDGE LIGHTING AND MARKINGS AND CIRCLING GUIDANCE LIGHTING (M/LF)**FAC: 1361****BFR Required: N**

Design Criteria: NAVAIR 51-50AAA-2, Visual Landing Aids Design Standards, Land-based Installations

Planning Criteria: P-80.3, Airfield Safety Clearances (Facility Planning Factor Criteria for Navy and Marine Corps Shore Installations, Appendix E)

13630-1 **DEFINITION.** This Category Code includes two groups of lights, Runway Edge Lights, which define the lateral limits of the pavement, and Circling Guidance Lights (CGLs), which enable an airborne aircrew to locate the runway while off to the side of the runway, and establish the proper traffic pattern.

13630-2 **RUNWAY EDGE LIGHTING SYSTEM.** Runway edge lighting consists of three types of lights including: Low Intensity Runway Edge Lights (LIRL); Medium Intensity Runway Edge Lighting (MIRL); and High Intensity Runway Edge Lighting (HIRL). Runway edge lights are installed parallel to the runway centerline for the length

of the runway. The intensity of edge lighting used depends upon dominant weather conditions over the airfield. Each type of runway edge lights defines the lateral limits of the usable runway surface for landings and takeoffs during nighttime operations and in reduced visibility. The runway edge lighting is a basic airfield lighting system. With its associated Threshold Lighting, Category Code 136 60, and runway end lighting, it can function without other lighting support. All runways intended for use at night or during Instrument Flight Rules (IFR) operations require edge lighting.

Edge lighting systems consists of two straight lines of lights with one line of lights located along each edge of the runway. The lights are equally spaced along the edge of the runway, bi-directional, and the emitted color shall be aviation white. For runways with displaced thresholds, edge lighting is installed at the edges of the displaced area if this area is used for rollouts and takeoffs. Edge lighting located in the displaced threshold area the color of the emitted light towards the approach zone shall be aviation red.

13630-2.1 **Edge Lights.** Runway edge lights are white lights equally spaced on each side of the runway with a maximum interval of 61 meters (200 feet). Runway edge lights are installed to provide visual guidance during takeoff and landing operations at night and under low visibility conditions. Requirements are expressed in terms of runway length; that is, runway lights programmed for a runway 3,200 meters (10,500 feet) long will be shown as 3,200 meters (10,500 feet) of runway lights. Consult NAVAIR 51-50AAA-2 for layout and spacing requirements.

13630-2.2 **Edge Markings.** Runway edge markings are continuous lines near each edge of the runway parallel to the runway centerline. The stripes are 0.914 meters (3 feet) wide. For runways 61 meters (200 feet) or less in width, the outer edge of these stripes shall be 0.61 meters (2 feet) from the nominal or designated edge of the runway. For runways more than 61 meters (200 feet) wide, the inner edges of the markings are 58 meters (190 feet) apart and symmetrical about the runway centerline. If the runway has a displaced threshold, the side stripes continue through the displaced section. Preferably, the edge markings extend to the runway ends but may terminate with the beginning of the threshold markings except where the threshold is displaced from the runway end. The color of the edge markings is retro-reflective white. Consult NAVAIR 51-50AAA-2 for layout and spacing requirements.

13630-3 **CIRCLING GUIDANCE LIGHTS.** Circling Guidance Lights (CGLs) are two straight lines of white lights with one line on each side of the runway with the beam emitted perpendicular to and away from the runway centerline. GCLs have a nominal 305 meter (1,000 foot) spacing and are placed outboard of the runway edge in line with the Runway Distance Markers, Category Code 134 64. They are used only for visual flight operations where conditions around the air installation, such as a metropolitan area or smog, confuse or obscure the runway when viewed from a circling aircraft. The need for circling guidance lights at a given air installation is determined by the particular airfield environment. Circling guidance lights requirements are also expressed in feet of runway length. Consult NAVAIR 51-50AAA-2 for layout and spacing requirements.

136 35 RUNWAY CENTERLINE LIGHTING AND MARKINGS (M/LF)**FAC: 1361****BFR Required: N**

Design Criteria: NAVAIR 51-50AAA-2, Visual Landing Aids Design Standards, Landbased Installations

Planning Criteria: P-80.3, Airfield Safety Clearances (Facility Planning Factor Criteria for Navy and Marine Corps Shore Installations, Appendix E)

13635-1 **RUNWAY CENTERLINE LIGHTING.** Runway centerline lighting provides visual aid to assist the aircrew in keeping the aircraft centered on the runway during take-off and after landing at night or in condition of reduced visibility. It is a supplement to Runway Edge Lighting and Markings and Circling Guidance Lighting, Category Code 136 30. White in-pavement lights are placed along the runway centerline at either 7.62 meter (25 foot) spacing of "tailhook resistant" lights or 15.2 meter (50 foot) spacing of standard duty lights. Lights are white when viewed from the landing threshold until the last 914 meters (3,000 feet) of the runway. The white lights alternate with red for the next 610 meters (2,000 feet), and are all red the final 305 meters (1,000 feet) in order to distinguish the runway's end.

13635-2 **REQUIREMENTS.** Runway centerline lighting is planned in accordance with mission requirements as listed in Basic Category Code series 136. Requirements are expressed in meters (feet) of runway length vice the length of the lighting circuit. Consult NAVAIR 51-50AAA-2 for layout and spacing requirements.

13635-3 **RUNWAY CENTERLINE MARKING.** Runway centerline markings are centered on the runway centerline. The markings are a broken line of 36.6 meters (120 foot) long stripes separated by blank spaces of 24.4 meters (80 feet) +/- 3.05 meters (10 feet). The first stripe from each end is 12.2 meters (40 feet) from the top of the designation number. The minimum width of stripes is 0.305 meters (1 foot) wide for basic runways and a minimum of 0.914 meters (3 feet) wide from other runways. The color of these markings is retro-reflective white.

136 36 SIMULATED CARRIER DECK LIGHTING (EA)**FAC: 1362****BFR Required: Y**

Design Criteria: NAVAIR 51-50AAA-2, Visual Landing Aids Design Standards, Land-based Installations

Planning Criteria: P-80.3, Airfield Safety Clearances (Facility Planning Factor Criteria for Navy and Marine Corps Shore Installations, Appendix E)

13636-1 **DEFINITION.** A simulated carrier deck is used to train pilots ashore for landing aircraft under simulated conditions of a carrier at sea. Simulated carrier deck lighting and markings permits training during the day, night, and adverse visibility conditions.

13636-1.1 **Lighting.** The carrier deck lighting consists of centerline lights, edge lights, and athwartship lights. The edge and athwartship lights form a 21.3

meter by 228 meter (70 foot by 748 foot) rectangle outlining the simulated carrier deck that is on the left side of the runway, as seen from the landing aircraft, and approximately 98 meters (320 feet) beyond the runway threshold. An Optical Landing Aid, Category Code 134-60, and Landing Signal Officer (LSO) station is also required. Consult NAVAIR 51-50AAA-2 for layout and spacing requirements.

13636-1.2 **Markings.** The simulated carrier deck markings supersede the standard runway markings, including the unpainted areas within the deck boundaries and are symmetrical about the designated deck centerline. The markings are painted on the runway surface. If the contrast of the markings against the runway is poor, the markings may be outlined with a lusterless black border. The markings shall consist of centerline markings, edge markings, and ramp athwartship markings. There is no athwartship line at the forward end of the deck. Consult NAVAIR 51-50AAA-2 for layout and spacing requirements.

13636-2 **REQUIREMENTS.** Simulated carrier deck lighting is required at all air installations designed by the Chief of Naval Operations (CNO) for Fleet Carrier Landing Practice (FCLP). Normally two sets are installed per runway, one at each end of the runway selected for FCLP.

136 45 WHEELS-UP/WAVE-OFF LIGHTING (M/LF)

FAC: 1362

BFR Required: N

Design Criteria: NAVAIR 51-50AAA-2, Visual Landing Aids Design Standards, Land-based Installations

Planning Criteria: P-80.3, Airfield Safety Clearances (Facility Planning Factor Criteria for Navy and Marine Corps Shore Installations, Appendix E)

13645-1 **DEFINITION.** Wheels-Up and Wave-Off Lights are provided to allow either the Wheel Watch, the Landing Signal Officer (LSO), or Control Tower personnel to determine if a landing aircraft has its landing gear fully extended and/or to signal to an aircrew to abort or “wave-off” a landing attempt.

13645-2 **REQUIREMENTS.** Wheels-up lights are a bar of 20 white lights installed under the approach path that are aimed upward and toward the threshold. They are intended to illuminate the underside of landing aircraft to permit observers to determine that the landing gear is fully lowered. The system also includes a pad for siting a portable Wheels Watch Shelter, Category Code 133-80. The light bar is placed 264 meters (980 feet) +/- 1.54 meters (5 feet), from the threshold under the approach path and on the same side of the extended runway centerline as the Control Tower.

Wave-off lights are used to signal to the aircrew to abort or “wave off” a landing attempt. Six pairs of flashing red lights, three pairs on each side of the runway, spotted 3.05 meters (10 feet) outboard of the runway edge at 270 meters, 510 meters, and 750 meters (900 feet, 1,700 feet, and 2,500 feet) from the runway threshold that are activated by either the Wheels Watch or Control Tower personnel. The lights flash when activated.

136 50 TAXIWAY LIGHTING AND MARKINGS (M/LF)**FAC: 1361****BFR Required: N**

Design Criteria: NAVAIR 51-50AAA-2, Visual Landing Aids Design Standards, Land-based Installations

Planning Criteria: P-80.3, Airfield Safety Clearances (Facility Planning Factor Criteria for Navy and Marine Corps Shore Installations, Appendix E)

13650-1 **DEFINITION.** Taxiway lighting and markings define the lateral limits and direction of a Taxiway, Category Code 112-10, to guide aircraft movement between the runway operational area and the aircraft parking area during night operations or conditions of poor visibility.

13650-2 **TAXIWAY LIGHTING SYSTEM REQUIREMENTS.** Taxiway lighting requirements are expressed in meters/feet of lighted taxiway length, not in length of lighting circuit. The total length of taxiway lighting is dependent upon the length of the taxiway itself, its turn radii, and its number of intersections and holding positions. The amount of taxiway lighting is expressed in meters (linear feet). Included in this category are taxiway edge lights, taxiway centerline lights, hold lights and guidance signs.

13650-2.1 **Taxiway Edge Lights.** Taxiway edge lights are elevated or semi-flush blue lights located on each side of the taxiway at intervals delineated in NAVAIR 51-50AAA-2. This interval varies based on the length and turn radii of the taxiway. Therefore, the number of lights cannot be determined without first knowing the geometry of the taxiway and airfield. Consult NAVAIR 51-50AAA-2 for layout information. Taxiway edge lighting is planned for all air installations conducting all-weather or night operations.

13650-2.2 **Taxiway Centerline Lights.** Taxiway centerline lights are semi-flush green lights placed in the pavement on the centerline of the taxiway. They are used to add the directional guidance required at high speed taxiway exits. They are also used to supplement edge lights wherever more positive guidance of aircraft is necessary, such as at complex taxiway intersections or large ramp areas where pilot confusion might occur. Again, the number of taxiway lights cannot be determined without knowing the geometry of the airfield. Consult NAVAIR 51-50AAA-2 for layout and spacing requirements.

13650-2.3 **Hold Lights.** Hold lights are a group of three semi-flush lights centered about the taxiway centerline at the holding position marker. For wide taxiways, five lights may be used. If the taxiway has centerline lighting in the area where the holding position lights are to be installed, the holding position lights shall be the same type as the centerline lights except with yellow filters. For intersections without centerline lights, three yellow lights, located in the center of the taxiway, perpendicular to the aircraft's direction of travel, shall be aimed towards the holding position. Holding position yellow lights are used for night marking of the painted hold positions. Their position and location are based on operational requirements. Consult NAVAIR 51-50AAA-2 for layout information.

13650-2.4 **Guidance Signs.** Taxiway guidance signs are internally lighted signs used to supplement taxiway lighting systems. They are placed at intersections of runways, taxiways with runways, taxiways with aprons, taxiways with taxiways, at refueling stations, and generally where direction or location information is required. The number of signs is based on the particular airfield requirements and is kept to a minimum. Consult NAVAIR 51-50AAA-2 for sign height limitations and letter text size.

13650-3 **TAXIWAY MARKINGS REQUIREMENTS.** Taxiway markings consist of a system of markings identified by the functions which they serve. The elements of taxiway markings include: taxiway centerline markings (required); holding position markings (standard and Category II, required); runway entrance and exit markings (required); TACAN checkpoint markings (required, if established); edge markings (optional); shoulder markings (optional); hazardous area markings (optional); and closed taxiway markings (optional). The markings shall be painted of the specified color applied to the taxiway surface except temporary hazardous area markings may use flags or barrier markings. Also, temporary closed taxiway markings may be of materials such as tape of that color that can be easily removed.

Taxiway centerline markings are a contiguous retro-reflective yellow stripe not less than 0.152 meters (6 inches) wide located along the taxiway axis. If taxiway centerline lights are installed, the axis of the centerline stripe may be offset no more than 0.305 meters (1 foot) from the taxiway centerline to avoid painting over the lights. These markings provide identification of a taxiway and longitudinal guidance for steering the aircraft. The markings continue across the intersecting taxiways or curve into the intersecting taxiway to indicate turns that are frequently used in taxiing. On curves or curved sections the markings are smooth curves and the minimum distance from the edge of the taxiway is not less than one-half the width of the taxiway. Consult NAVAIR 51-50AAA-2 for layout information.

13650-4 **SPECIAL SITUATIONS.** The use of runways as taxiways should be avoided; however, where the existing airfield layout requires the use of the runway as a taxipath, separate taxiway fixtures and circuits, in addition to the runway lighting system, are used. Consult NAVAIR 51-50AAA-2 for lamp layout and spacing.

136 55 TOUCHDOWN ZONE LIGHTING AND MARKING (M/LF)

FAC: 1362

BFR Required: N

Design Criteria: NAVAIR 51-50AAA-2, Visual Landing Aids Design Standards, Land-based Installations

Planning Criteria: P-80.3, Airfield Safety Clearances (Facility Planning Factor Criteria for Navy and Marine Corps Shore Installations, Appendix E)

13655-1 **LIGHTING REQUIREMENTS.** Touchdown zone lighting delineates the touchdown zone on the runway and provides directional and roll guidance for aircraft approaching the threshold. It provides visual cues for more accurately centering the aircraft on the runway, adjusting attitude for touchdown, and determining the touchdown

position. The lighting consists of bars of white lights in the pavement on each side of the runway centerline. Thirty pairs of bars are spaced along the runway at 30.5 meters (100 foot) intervals for a total distance of 914 meters (3,000 feet). Touchdown zone lighting is planned in accordance with mission requirements as listed in Basic Category Code group 136. A set of lights is required only on the end of the runway with approach lighting.

13655-2 MARKING REQUIREMENTS. Touchdown zone markings consist of groups of three, two, and one rectangular bars symmetrically arranged impairs about the runway centerline. Each bar is 1.83 meters (6 feet) wide and 23.4 meters (75 feet) long. The bars within a group are spaced 1.52 meters (5 feet) apart. The second group of bars from the threshold shall be fixed distance markings as single bars 9.14 meters (30 feet) wide and 45.7 meters (150 feet) in length. For runways less than 45.7 meters (150 feet) wide, the width of the bars and spaces is reduced proportionately. The inner edges of the bars in a pair are 22 meters (72 feet) apart. The first pair of bars begins 152 meters (500 feet) down the runway from the beginning of the threshold markings (159 meters (520 feet) from the runway end).

On shorter runways, these pairs of bars that would extend to within 274 meters (900 feet) of the midpoint of the runway are eliminated. The color of touchdown zone markings is retro-reflective white. Consult NAVAIR 51-50AAA-2 for layout and spacing requirements.

136 60 THRESHOLD LIGHTING AND MARKINGS (EA)

FAC: 1362

BFR Required: N

Design Criteria: NAVAIR 51-50AAA-2, Visual Landing Aids Design Standards, Land-based Installations

Planning Criteria: P-80.3, Airfield Safety Clearances (Facility Planning Factor Criteria for Navy and Marine Corps Shore Installations, Appendix E)

13660-1 THRESHOLD LIGHTING. Threshold lighting is a system of lights defining the ends of the usable runway surface. They include threshold lights, displaced threshold lights, Runway End Identification Lights (REIL) and runway end lights. The threshold lights are displaced from the extremity of the runway when a portion is unavailable for normal operations. REIL and runway end lights enable a pilot to positively identify the ends of the runway from a distance during night-non-precision approach operations.

13660-1.1 Threshold Lights. Threshold lights are installed to provide positive identification of the beginning of the operational runway surface for approaching aircraft at night or under Instrument Flight Rules (IFR) conditions. Threshold lighting consists of two groups of lights located symmetrically about and perpendicular to the runway centerline at each end of the runway, both inboard and outboard of the line of the runway edge lights. The lights show green toward the approach zone and, if at an extremity, red toward the runway. Threshold lights are planned for all lighted

runways, but more lights are required where an approach lighting system is used as displayed in NAVAIR 51-50AAA-2.

13660-1.2 **Displaced Threshold Lights.** Displaced threshold lighting is used only if a portion of the end of the runway is unusable for landing but is available for rollout and takeoff. When this condition exists because of obstructions or other reasons, the lighting is modified to delineate the extent of runway which is available to aircraft approaching from either direction. This is accomplished by displacing and changing the threshold lights to indicate the new threshold location for landing aircraft and equipping the intervening runway edge lights with filters.

13660-1.3 **Runway End Identification Lights (REIL).** REIL consist of two synchronized flashing lights near the runway threshold to provide rapid and positive identification of the approach end of a runway. These lights have been adopted to replace the obsolete runway identification lights formerly employed as the standard.

13660-1.4 **Runway End Lights.** Runway end lights are installed to define the end of the operational runway for aircraft on landing rollout and takeoff. A minimum of ten red lights are arranged in two groups symmetrical about and perpendicular to the runway centerline pointing toward the runway side of the threshold at each end of the runway. Intervals between lights in each group are not to exceed 3.05 meters (10 feet). They are to be positioned not more than 1.52 meters (5 feet) beyond the length of usable pavement and the outboard most light in each group will be in the line of the runway edge lights. Where runway end lights and threshold lights are to be installed in the same location, bi-directional red/green lights may be used with the appropriate color lens. If located at the end of usable pavement in displaced threshold areas, they are bi-directional red.

13660-2 **THRESHOLD MARKING.** Threshold markings consist of ten stripes, five on each side, parallel and symmetrical about the runway centerline. The color of these markings is retro-reflective white. If the runway is less than 61 meters (200 feet) wide, the overall width of the threshold markings is 6.1 meters (20 feet) less than the runway width. The width of the stripes and spaces between the stripes is reduced proportionately. Consult NAVAIR 51-50AAA-2 for layout and spacing requirements.

136 65 HELIPORT LIGHTING AND MARKING (M/LF)

FAC: 1361

BFR Required: N

Design Criteria: NAVAIR 51-50AAA-2, Visual Landing Aids Design Standards, Land-based Installations

Planning Criteria: P-80.3, Airfield Safety Clearances (Facility Planning Factor Criteria for Navy and Marine Corps Shore Installations, Appendix E)

13665-1 **DEFINITION.** Heliport lighting is a system of lights arranged to clearly define the helicopter landing pad for operations at night and during periods of poor visibility. Heliport lighting includes all visual reference aspects of the approach and

landing of rotary wing aircraft. This includes visual aids, markings, perimeter and approach lights, and runway and taxiway lights.

13665-2 **REQUIREMENTS.** The basic heliport lighting requirement is perimeter lighting and landing direction lights. Approach direction lights and depth perception lighting may also be required. Perimeter lighting and landing direction lights are planned for all helicopter pads designated for night or all-weather operations and when authorized as an operational requirement at a specific location. Landing direction lights are used to indicate a preferred landing direction and to give side orientation as wing bars. Approach direction lights are added if additional approach guidance is required. The need for depth perception lighting (pad inset lights and/or flood lights) is determined by heliport location, steepness of approach, and prevailing environmental conditions.

Heliport lighting and marking systems are comprised of numerous types of pavement markings and lighting systems. They include:

13665-2.1 **Helipad Identification Markings.** Included in this category are identification markings and perimeter markings. Helipad identification marking for a paved helipad shall be a capital letter "H". The "H" marking shall be located in the center of the landing area, and oriented with the preferred approach direction. The dimensions shall vary with size of the landing and takeoff area. The color of the "H" is aviation white, and must be reflective if the pad is used at night. If the paved surface is a light color and improved contrast is needed, the identification marker shall be outlined with a lusterless black border. Perimeter markings define the safe landing area and are oriented with the sides of the parallel square to the letter "H". The perimeter markings consist of the corners and edge bars. The corners form right angles and the edge bars are located midway between the corner markings. The outer edges of the markings are the designated limits of the landing and takeoff area. These markings are aviation white and if the helipad is used at night shall be reflective. Again, if contrast is needed, these markings will be outlined with a black border.

13665-2.2 **Helipad Perimeter Lights.** Helipad perimeter lights consist of a row of lights along or near the four sides of a helipad. Typically, these lights are elevated although semi-flush lights may be used in areas where helicopters with wheels may be taxiing on the surface between the helipad and parking or service areas. Both type of fixtures emit omni-directional yellow light.

13665-2.3 **Helipad Approach Lights.** Helipad approach lights consist of a row of landing direction lights perpendicular to the centerline of the perimeter lights, beginning approximately 7.62 meters (25 feet) from the midpoint of the perimeter light centerline. These lights are usually elevated although semi-flush lights may be use in areas where helicopters with wheels may be taxiing on the surface. These lights emit omni-directional beams. The helipad approach light system entails two types of lights. The first are Landing Directional Lights. These consist of a single row of six yellow lights outward from the helipad perimeter lights centered on the helipad in the established direction for the approach. The second type of light is the Approach Direction Lights. This system is comprised of two parallel rows of lights

extending outward from the last landing direction light. Each row shall have five pairs of white lights.

13665-2.4 **Heliport Runway Lights.** Heliport runway lights are required for runways doing night operations. Yellow lights define the limits of the runway and are spaced at 4.57 meter (15 foot) intervals at the line of perimeter lights and extend outward in the direction of the preferred approach/takeoff path. These lights are an optional feature that is installed when it is necessary to provide directional guidance.

13665-2.5 **Heliport Taxiway Lights.** Heliport taxiways are defined while flush mounted green lights along the taxiway centerline. Blue omni-directional lights define taxiway route edges. The lights are spaced at 7.62 meter (25 foot) intervals on straight sections. On curves, this distance should remain the same; however, there must be at least four lights defining the turn.

137 SHIP NAVIGATION AND TRAFFIC AIDS-BUILDINGS

137-1 This code group applies to buildings for housing sea traffic control, navigation aids and navigation services.

137 10 METEOROLOGY AND OCEANOGRAPHY BUILDING (SF) [DELETE]

FAC: 1371

BFR Required: Y

13710-1 This category is deleted. All future requirements should be reassigned, revised, and calculated as a Category Code 13115 "Communications, Information, or Intelligence Analysis Facility".

137 20 LIGHTHOUSE (M2/SF)

FAC: 1371

BFR Required: Y

13720-1 **DEFINITION.** A lighthouse is a structure that houses a navigation beacon that may emit light, sound, radio, radar, or a combination thereof. It may be onshore or offshore. Construction is done overseas when appropriate by the Naval Facilities Engineering Command.

13720-2 **REQUIREMENTS.** Criteria are supplied by the U.S. Coast Guard. See UFC 4-141-10N for details.

138 SHIP NAVIGATION AND TRAFFIC AIDS-OTHER THAN BUILDINGS

138-1 This code group applies to structures which function as sea traffic navigation/traffic aids.

138 10 BEACON - SHIP (EA)

FAC: 1381

BFR Required: N

13810-1 **DEFINITION.** The U.S. Coast Guard has specific jurisdiction over all aids to navigation (day beacons, buoys, foghorns, etc.,) in the continental United States and in all outlying territories and possessions. Day beacons are unlighted structures used to mark isolated dangers or channels, edges, or alignment. They are painted white, black, green, or red, either separately or in combination. Day beacons also have reflectors for night use. See Harbor and Coastal Facilities, UFC 4-150-06, for technical information, and International Rules of Road and Inland Waterways, U.S. Coast Guard, for regulations.

138 20 NAVIGATION AID TARGET (EA)

FAC: 1381

BFR Required: N

13820-1 **DEFINITION.** This Category Code is to be used for navigational aid targets which are a part of maritime navigational aids.

13820-2 **REQUIREMENTS.** These facilities are planned on an individual basis.

138 25 ANTENNA-NAVIGATION (EA)

FAC: 1381

BFR Required: N

13825-1 **DEFINITION.** This Category Code is to be used for antennas or antenna systems which are a part of maritime navigational aids.

13825-2 **REQUIREMENTS.** These facilities are planned on an individual basis.

140 LAND OPERATIONAL BUILDINGS

141 OPERATIONAL - BUILDINGS

141 11 AIR PASSENGER TERMINAL (SF)

FAC: 1412

BFR Required: Y

14111-1 **DEFINITION.** The air passenger terminal provides facilities for processing authorized passengers and their baggage and for processing incidental freight. Space is provided in the terminal for the following functional areas: administrative space, baggage claim room, check-in counter, minor freight storage, information counter, and waiting lounge with food concessions. (For air cargo terminal, see Category Code 141 12.) The space to be planned is based on an analysis of the passenger traffic anticipated. A terminal is planned for those air stations where passenger traffic is projected to exceed 30 passengers during a typical peak hour.

14111-2 Due to the irregular and often unpredictable passenger flow in military air terminals, the facility requirements must be justified in each individual case where a terminal is warranted. Supporting data must include historic passenger flow figures and mode in sufficient detail to permit validation of facility scope.

141 12 AIR CARGO TERMINAL (SF)

FAC: 1412

BFR Required: Y

14112-1 **DEFINITION.** An air cargo terminal is planned for air stations where cargo and freight handling exceeds 10,000 pounds per day. The air cargo terminal is separate from the air passenger terminal (Code 141 11) where only incidental freight is handled. Air cargo terminal functions include receipt of packages, control documentation, palletization, and holding for shipment, aircraft loading and unloading, package sorting, and loading on trucks.

14112-2 Space required for air cargo terminal operations is based on the weight of cargo to be handled as determined by station survey. Terminals are planned using the space allowances in Table 14112-1.

Table 14112-1 Space Allowances - Air Cargo Terminal

Average Daily Load (pounds) ⁽¹⁾	Air Cargo Terminal Type	Gross SF Area
10,000 - 20,000	Small, non-mechanical	7,720
20,000 - 40,000	Small, mechanical	32,500
40,000 - 100,000	Medium, mechanical	44,500
100,000 - 160,000	Large, mechanical	54,500

(1) Average Daily Load includes cargo originating, terminating, and being re-handled through the terminal.

14112-3 Air cargo terminal facilities must be adjacent to the transient aircraft apron area but siting shall not violate aircraft pavement clearance criteria. Exterior pavement requirements include road access, access to aircraft apron, and non-organizational vehicle parking area (see Category Code 852 10).

141 20 AIRCRAFT FIRE AND RESCUE STATION (SF)**FAC: 1411****BFR Required: Y**

Refer to Design Criteria, UFC 4-730-10 Fire Stations, for technical requirements at <https://www.wbdg.org/ffc/dod/unified-facilities-criteria-ufc/ufc-4-730-10>.

The Space Planning Spreadsheet is located at <https://www.wbdg.org/ffc/dod/unified-facilities-space-program-sustainability-spreadsheets>.

14120-1 **DEFINITION.** This space criteria applies to Installation fire and rescue facilities which provide fire protection and emergency rescue services for pilots and aircraft.

14120-1.1 When feasible, the aircraft fire and rescue station is combined with the structural fire station (Category Code 730 10) to develop the total space allocation for one complete emergency facility, Category Code 141 25 "Combined Structural / Aircraft Fire / Rescue Station".

14120-2 **REQUIREMENT.** The number of fire stations required on an Installation will be determined by the necessary response time for the type and function of facilities requiring fire protection. This analysis will be provided by Commander Navy Installations Command (CNIC) N30 or Marine Corps Installations Command (MCICOM) G3.

14120-3 **SCOPE.** Refer to CCN 730 10 for explanation of the scope, types, classes and function of the fire station facility.

14120-4.1 The total space allocation is based on the number of fire and rescue vehicles assigned to the aircraft fire and rescue function, at both the parent and outlying fields.

14120-2.2 Covered space, either building or shed, is provided for all assigned fire and rescue vehicles and equipment. Generally, the building element houses the active vehicles required to protect the parent Installation. The shed element houses: (1) the active foamer and crane, (2) the active vehicles to support the outlying fields, and (3) the spare vehicles for maintenance and reserve for both parent and outlying fields.

14120-4 **FUNCTIONAL AREAS.** Aircraft Fire and Rescue Stations consist of apparatus bays and support areas, equipment and gear storage areas (for fire extinguishers, self-contained breathing apparatus (SCBA), protective clothing, hoses, firefighting agents, etc.), dispatch office, administrative offices, training facilities, living quarters, recreation and dining facilities, and possibly an emergency operations center and/or apparatus and equipment maintenance areas (if required by Installation mission requirements).

14120-3 **SPACE ALLOWANCE.** The Total Gross Building area is determined using the space planning spreadsheet. This area will be the sum of the building and shed space allowance at both the parent and outlying field locations. The planner must account for all fire and rescue vehicles at the location and determine how many will be housed in the building and how many will be housed under sheds. The planner will reflect the following on the BFR: (1) the total shed area equals the number of vehicles housed in sheds times the area of the vehicle bays, and (2) the total building area is the Total Gross Building area minus the total shed area.

14120-3.1 Pavement is provided adjacent to the station for 25 percent of the vehicles and for one vehicle wash rack.

14120-3.2 The Fire and Rescue Vehicles Alert Pad is computed separately under Category Code 116 60.

Figure 141-20 Sample Computation - Aircraft Fire and Rescue Station

Assume an Air Station operates with outlying fields. The space planning spreadsheet has indicated that the Total Gross Building area is 11,700 GSF. The planner has determined that 40% of the fire and rescue vehicles will be housed in sheds, both at the parent and the outlying fields. The total shed requirement is 4,752 GSF, which is split into 2,160 GSF at the parent station and 2,592 GSF at the outlying fields. The building area will be 6,948 GSF. The total building and shed space sum up as follows:

	Building Area - GSF	Shed Area - GSF
Parent Station	6,948	2,160
Outlying Fields	0	2,592
Total	6,948	4,752
Total Gross Building Area	11,700 GSF	

The total space to show on the BFRL is $6,948 + 4,752 = 11,700$ SF gross for the parent air station. No space to house the vehicles is required at any of the outlying fields.

141 25 COMBINED STRUCTURAL / AIRCRAFT FIRE / RESCUE STATION (SF)

FAC: 1411

BFR Required: Y

14125-1 **DEFINITION.** A combined structural/aircraft fire/rescue station is planned under certain conditions to serve the function of a structural fire station (Category Code 730 10) and an aircraft fire and rescue station (Category Code 141 20). The combined facility is planned for a location that satisfies the response time and distance requirements for both the structural fire and the aircraft fire and rescue stations.

14125-2 The station must provide adequate support of airfield activities and protection for all buildings and structures. The size of the building is planned to house the aircraft fire and rescue vehicles required plus the structural fire vehicles required. The computations are done as indicated in Category Codes 141 20, Aircraft Fire and Rescue Station, and 730 10, Fire Station. The sum of the areas required for the structural fire station and the aircraft fire and rescue station is the total building area for the combined station.

14125-3 Protection against structural fires may be provided in part or completely by community resources. The method for development of reciprocal agreements between Navy and a municipality for mutual fire protection may be found in NAVMATINST 11320.10.

141 30 AIRCRAFT LINE OPERATIONS BUILDING (SF)

FAC: 1412

BFR Required: Y

14130-1 **DEFINITION.** The aircraft line operations building is a structure used to centralize ground operations of the flight line. The building is utilized in keeping of squadron daily flight books, aircraft status boards, and bulletin boards and as support for line operations personnel by providing shelter, a water cooler, and a chemical toilet. The aircraft line operations building is a standard 12- by 20-foot portable building with a building area of 240 square feet gross.

14130-2 One line operations building may be planned for each hangar module when the distance between the squadron's parked aircraft and the hangar is greater than 1,000 feet.

NOTE: Criteria for this facility indicates that it is to be portable and therefore carried as collateral equipment, when acquired. Collateral equipment is not Class II real property and cannot be included in the real property inventory. However, this category code is being retained for real property inventory purposes since many of the existing facilities are not portable and accordingly must be reported in the RPI.

141 40 AIRCRAFT OPERATIONS BUILDING (SF)

FAC: 1412

BFR Required: Y

14140-1 **DEFINITION.** An aircraft operations building is planned for all Navy air stations, auxiliary air stations, and air facilities. The building houses the administration of flight operational activities with all supporting functions including flight control, communications, and weather services. The operations building adjoins the airfield control tower and the radar air traffic control center where siting requirements permit. See Table 14140-1 for space allowances.

**Table 14140-1
Aircraft Operations Building**

Installation	Gross Area Sq. Ft.
Air Station	12,637
Air Facility	9,760

**141 41 MARINE AIR TRAFFIC CONTROL UNIT (MATCU)
OPERATIONS BUILDING (SF)**

FAC: 1412

BFR Required: Y

14141-1 **DEFINITION.** The MATCU performs a combined function similar to that accomplished in Category Codes 134 40, Ground Control Approach (GCA) System; 133 25, TACAN Building; and 133 75, Air Surveillance Radar (ASR) Building. Depending on the level of aircraft operations, the MATCU operations building may provide the sole GCA support at an air installation or may supplement and be in addition to permanent ASR, TACAN, and GCA facilities. A MATCU operations building should not be planned without prior coordination with and approval of the Commandant of the Marine Corps (LFF-1).

14141-2 When authorized, the MATCU operations building shall not exceed 9,130 gross square feet.

141 42 AIR INTELLIGENCE SUPPORT CENTER (SF)

FAC: 1444

BFR Required: Y

14142-1 **DEFINITION.** This facility, also known as a Joint Intelligence Center (JIC), is used to store and disseminate classified material for mission planning, pilot training and briefings in support of attack aircraft operations. The design and size of the center will be determined by the type and amount of equipment to be installed and the number of standard attack squadrons assigned to a station. Typical spaces include: administrative, library/chart storage, classroom, special security office, planning rooms, briefing rooms, photo intelligence interpretation room and storage. No specific planning criteria are currently available for this facility. Inquiries regarding space allocations should be forwarded to OPNAV N2.

141 60 VISUAL INFORMATION (VI) FACILITY (SF)**FAC: 1441****BFR Required: Y**

14160-1 **DEFINITION.** This category code was previously referred to as a "Photographic Building". Navy visual information (VI) is a professional visual communication capability closely associated with Navy public affairs (PA). The role of Navy VI is to support the following activity missions and functions:

- VI documentation (VIDOC), which includes combat camera (COMCAM) documentation, operational documentation (OPDOC), technical documentation (TECDOC) and sub functions using graphic arts, motion media, still photographic, audio and other VI systems
- VI production in support of Navy operations, training, and other functions;
- Support of DoD records centers
- Ship/shore VI activities which include: motion media production, still photographic production, graphic arts production, and other VI services needed at ship/base level

A VI Facility is a building or a space within a building that houses an authorized VI activity, which is a function within an organization whose principal responsibility is to provide VI products and/or services and must meet specific requirements as described in OPNAVINST 3104.1A, Chapter 0201. All VI Activities must first be approved by CNO Office of the Assistant for Visual Information N09C2 and assigned a Defense Activity number (DVIAN) prior to establishing a VI facility. Requests for establishing or modifying Navy VI activities must correspond with the guidance for activity establishment or modification prescribed in OPNAVINST 5400.44 (5440.169D); and, must meet CA requirements prescribed in OPNAVINST 4860.7D.

14160-2 **ALLOWANCE.** The size of a VI Facility will be determined by an engineering analysis of the space required to support the VI activity mission, functions, and systems. Basic Facility Requirements (BFR) creation/revision must be validated through the Commanding Officer and Public Affairs Officer of an installation.

141 65 FLEET RECONNAISSANCE PHOTOGRAPHIC LABORATORY (SF)**FAC: 1441****BFR Required: Y**

14165-1 **DEFINITION.** These facilities are no longer programmed and are for inventory purposes only. All new Visual Information (VI) facilities should be captured under either CCN 14142 Air Intelligence Support Center or CCN 14160 Visual Information (VI) Facility.

141 70 CONTROL TOWER (SF)**FAC: 1413****BFR Required: Y****Planning Criteria:** UFC 3-260-01, Airfield and Heliport Planning and Design**Design Criteria:** UFC 4-133-01, Air Traffic Control and Air Operations Facilities

14170-1 **DEFINITION.** A control tower provides space for equipment and personnel to control aircraft traffic. It is an elevated structure having an unobstructed line-of sight to the airfield approach areas, runways, taxiways, aircraft parking areas, and all other operational areas over which aircraft movements must be controlled. This category code is used for the control tower in all cases even though the tower may be an independent structure or combined with a RATCC or an aircraft operations building. If at all possible, the control tower should be an integral unit with the RATCC (Category Code 133 71, thus providing a complete, integrated air traffic control facility. A control tower is planned for each installation where aircraft are based. It is not planned for outlying fields and auxiliary landing fields unless specifically authorized by competent authority. The minimum installation is the basic tower containing an entrance level, intermediate levels, and the control tower cab. The area of floor space for a control tower of standard design with six floors plus the control room is 2,956 square feet gross. Towers of increased height can be provided by adding incremental levels.

141 81 GROUND CONTROL APPROACH CREW FACILITY (SF)**FAC: 1412****BFR Required: Y**

14181-1 **DEFINITION.** The ground control approach (GCA) crew facility provides a ready room for on duty personnel assigned to the GCA van. The facility consists of two (2) standard design skid-mounted shelters (each 12 feet by 20 feet). The crew facility is authorized whenever the mobile GCA unit is furnished.

NOTE: Criteria for this facility indicates that it is to be portable and therefore carried as collateral equipment, when acquired. Collateral equipment is not Class II real property and cannot be included in the real property inventory. However, this category code is being retained for real property inventory purposes since many of the existing facilities are not portable and accordingly must be reported in the RPI.

141V 82 FULL PRESSURE SUIT FACILITY (SF)**FAC: 1412****BFR Required: Y**

14182-1 **DEFINITION.** Pressure suit maintenance is normally performed in the Aviation Life Support Systems Shop (Non-Navair Depot), Category Code 211 75. Special justification is required to provide a separate facility for this purpose.

141 87 LIQUID OXYGEN/NITROGEN FACILITY (SF)**FAC: 4122****BFR Required: Y**

14187-1 **DEFINITION.** A liquid oxygen/nitrogen facility is required at each Navy and Marine Corps air station where 50 or more attack and fighter-type aircraft are assigned. Smaller numbers of aircraft are provided with these gases by bottled gas from commercial suppliers. The facility provides for storage, vaporization, and transfer of non-industrial oxygen and nitrogen and for test and repair of cryogenic equipment associated with aviator and aircraft support. Liquid and gaseous forms of both oxygen and nitrogen, as well as hot nitrogen gas for purging equipment, are handled. The facility includes liquid storage tanks, vaporizing units, transfer areas, cart and tank filling and storage areas, repair shops, and office space. Port land cement concrete driveways, loading ramps, and cart parking areas are required. A building with a gross area of 2,704 SF is adequate for all needs. The facility has a storage capacity of 4,000 gallons each of bulk liquid oxygen and nitrogen and 150 cylinders of each gas. The size of the transfer areas may be reduced if a station survey indicates a lesser requirement for cylinder storage.

14187-3 MARINE CORPS CRYOGENICS FACILITY. A Marine Corps cryogenics facility provides for operational support of a Marine Aircraft Group and accommodates in garrison the expeditionary liquid oxygen/nitrogen generating equipment assigned. A Marine Corps cryogenics facility does not supplant the liquid oxygen/nitrogen facility at a Marine Corps air station. Generally, two generators are assigned to each Group. The exceedingly high noise level of the turbine-powered expeditionary liquid oxygen/nitrogen generator necessitates locating the facility in a remote area. The facility consists of a generator area, a cylinder fill area, cylinder and cart storage shelter, and main building. The generator area has a concrete pad, an underground fuel tank, exterior lighting, electric power, water, and an out building with a gross area of 246 square feet. Five hundred and ten square yards of concrete and 5,000 gallons of fuel storage are provided for a single generator. One thousand feet from the nearest generator is a shelter of 1,258 square feet gross area where gas cylinders are filled and converters and liquid oxygen and liquid nitrogen carts and cylinders are stored.

14187-4 The main building of the Marine Corps cryogenics facility has a gross area of 3,570 square feet and is located no closer than 100 feet from the shelter. The main building contains offices, toilets, classroom, maintenance shop, and repair parts storage. Because of the training mission conducted at this facility, normally only one generator is in production at a time. Hence, the storage shelter and the main building usually may be shared by all Groups utilizing this facility. The size of either the storage shelter or the main building may be modified if a survey indicates a different requirement.

141 88 HARDENED AIRCRAFT SHELTER (SF)
FAC: 1465
BFR Required: Y

14188-1 No criteria is currently available for this Category Code.

142 OPERATIONAL – HELIUM PLANTS

142 10 HELIUM PROCESSING PLANT BUILDING (SF)
FAC: 1421
BFR Required: Y

14210-1 No criteria is currently available for this Category Code.

142 19 HELIUM STORAGE BUILDING (SF)
FAC: 1421
BFR Required: Y

14219-1 No criteria is currently available for this Category Code.

142 20 HELIUM STORAGE FACILITY (EA)
FAC: 1422
BFR Required: Y

14220-1 No criteria is currently available for this Category Code.

143 SHIP AND OTHER OPERATIONAL-BUILDINGS

143 08 EXPEDITIONARY OPS BOAT MAINTENANCE REPAIR FACILITY (SF)
FAC: 2133
BFR Required: Y

14308-1 **DEFINITION.** An Expeditionary Operations Boat Maintenance Facility provides spaces for expeditionary units to perform continuous maintenance on boats. The facility will provide maintenance bays, a tool room, parts room, oily water separator system, overhead crane, and administrative support space.

14308-2 **REQUIREMENT CALCULATIONS.** Criteria is currently being developed for this category code. In the interim, please contact NAVFAC Atlantic AM2 for space allowance information.

143 09 EXPEDITIONARY OPS SUPPORT FACILITY (SF)**FAC: 1444****BFR Required: Y**

14309-1 **DEFINITION.** An Expeditionary Operations Support Module (EOSM) provides the organic components of an expeditionary command and guidelines for associated CCNs to be used to support them. The EOSM would define the following attributes: Expeditionary Administration, (at a 80% of standard space allowance), Medical (A Contingency Aid Station provides medical care at the local level for the Expeditionary commands), Sensitive Compartmented Information Facility (SCIF), Mission Planning Cell (may or may not be part of SCIF), Training Classrooms (not NETC associated training), Armory (at a reduced footprint from the CCN 143-45), and Locker and Shower spaces to support the physical training requirement of an Expeditionary Combat Command.

14309-2 **ALLOWANCE.** Space allowances are being developed. Questions regarding criteria can be directed to the NAVFAC Atlantic Expeditionary Operations criteria manager.

143 10 EMERGENCY VEHICLE GARAGE (SF)**FAC: 5307****BFR Required: Y**

14310-1 **DEFINITION.** This is a building for official emergency and alert vehicles, such as an ambulance. It is justified in instances when immediate response required by special waterfront operational vehicle. The building protects these vehicles from extreme weather to improve operational availability. The building is not used for vehicle services nor housing personnel. This category code excludes shelters used for aircraft and community fire and rescue vehicles, see Category Codes 141 20, 141 25, and 730 10.

The size of the garage is determined by the vehicle area plus nominal clearances surrounding the vehicle.

- A. Typically, three feet of clearance on each side is sufficient plus a gross to net factor of 1.05.
- B. In cases where vehicle side doors or access panels' clearances are greater than three feet, larger clearances may be justified.
- C. The distance between two vehicles should be the same as the side vehicle clearance.
- D. The front-end clearance should be no more than one foot.
- E. The rear clearance would vary the same as side clearances and depend on loading and accessibility. Three feet should be sufficient in most cases.
- F. A carport type shelter may be provided where the air conditioning design temperature on a 10% basis exceeds 87°F dry bulb.

- G. A garage may be provided where the heating design temperature on a 97.5% basis is less than 11°F dry bulb.

143 11 OPERATIONAL VEHICLE GARAGE (SF)

FAC: 1444

BFR Required: Y

14311-1 **DEFINITION.** An operational vehicle garage is used for the storage of vehicles which are not utilized on a daily basis and which are exposed to adverse weather conditions that would have a detrimental effect upon them if stored out in the open. Accordingly, the type of vehicle stored, frequency of use and climatic conditions, will determine whether this type of facility is warranted.

14311-2 **INCLUSIONS/EXCLUSIONS.** This category code excludes 216 45 Line Vehicle Parking for airfield equipment, 214 40 Holding Shed for Public Works Transportation vehicles awaiting maintenance, 218 65 Equipment Holding Shed for Public Works Transportation construction vehicles and equipment, and 219 20 Pavement and Grounds Equipment Shed. This category code also excludes vehicles and equipment maintained and operated by the Public Works Transportation Department. This category code includes operational vehicles maintained by Naval Special Warfare Groups, Naval Construction Battalions, and other groups that are responsible for the maintenance and upkeep of their company vehicles. Some of the vehicles that may require environmental protection include MK V boats and Ridged Hulled Inflatable Boats (RHIBs). These types of boats have rubber hulls that can deteriorate more quickly when exposed to sun and extreme temperatures creating a significant increase in maintenance expense of these vehicles. A Construction Battalion may have all sorts of heavy construction equipment like pavers and backhoes, etc.

14311-3 **REQUIREMENT CALCULATIONS.** To calculate the total gross are for this facility, first tally the quantity for each type of vehicle. Assign a "type code" per the Type Code and NSF Table 14311-1, based on the length of the item. Next, develop the Civil Engineering Support Equipment (CESE)/Service Craft & Boat Support System (SABAR) NSF requirements in accordance with Tables 14311-1 and 14311-2, to determine the total NSF required to store the command's equipment. Add 250 SF for a Mechanical Room for the fire suppressant system. Sum the total NSF and the 250 SF (mech. room) to determine the total NSF that is required. Based on the Net to Gross (NTG) Table 14311-3, multiply the total NSF times the correct NTG factor to determine the Gross Square Feet (GSF). For the final GSF, round up to nearest whole number. A ratio of between 1.5 and 3 (length to width) of the overall facility is desired, if possible. If an existing facility is converted to this use, an increase of fifteen percent may be added to the total area in order compensate for incompatible column spacing, wall, etc.

Table 14311-1: Type Code and NSF Table

Size	Gen Description	Type Code	NSF
0 - 5 FT	Non-mechanized CESE and SABAR (ex: Generators, Air Conditioner/Heating Units)	1A	108
5 - 10 FT	Non-mechanized CESE and SABAR (ex: Fuel Water SIXCON, Motors, Pumps, Generators, TRICONS)	A	168
10 - 15 FT	Vehicles and non-mechanized CESE and SABAR (ex: Trailers, Fork Lifts, Small Zodiac Boats)	1B	228
15 - 20 FT	Vehicles and non-mechanized CESE and SABAR (ex: Passenger Vehicles, HMMWV, Light Plant, Fork Lifts, Small Zodiac Boats)	B	288
20 - 30 FT	Large CESE and SABAR (ex: MTRV, Fuel Trucks, Boats < 30FT)	C	408
30 - 40 FT	Extra Large CESE and SABAR (ex: Boats > 30FT, MTRVs, Scrapers, Water Well, Semi Trailers)	D	528
40 - 50 FT	Extra Large CESE and SABAR (ex: Boats > 40FT, Crane, Scrapers, Water Well, Semi Trailers)	E	648
50 - 60 FT	Extra Large CESE and SABAR (ex: Boats > 50FT, Semi Trailers, lowboy 55T)	F	768
60 - 70 FT	Extra Large CESE and SABAR (ex: Prime Mover and Boats > 60FT (11M w/ Prime Mover))	G	888

NSF: storage lanes are 12' wide (which includes side to side clearance for Inspection X length of component plus 2' front/back. The addition of the side to side and front/back is to provide space for minor Preventive Maintenance.

**Example Table 14311-2:
CESE/SABAR NSF Calculation Table**

Description	Type Code	Total Qty	NSF/Item	Total NSF
Assembly:10178-AIR CONDITIONER / HEATING UNIT (IECU)	1A	3	108	324
Assembly:04250; SHORT DESC: COMPRESSOR,RECIPROCATING	1A	5	108	540
Assembly: 52680; SHORT DESC: MK18 56KW GENERATOR	A	8	168	1344
Assembly:088002; SHORT DESC: TRLR 400G TANK POTABLE WATER	1B	3	228	684
Assembly:06700; SHORT DESC: JLTV HEAVY GUN CARRIER W/ OPTION KITS	B	12	288	3456
Assembly:036091; SHORT DESC: HMMWV M1151A1B1 A-KIT	B	12	288	3456

Description	Type Code	Total Qty	NSF/Item	Total NSF
Assembly:036371; SHORT DESC: LSSV MAINT UTILITY CREW CAB W/ A-KIT	C	5	408	2040
Assembly: 70005; SHORT DESC: MEDIUM SERVICE SUPPORT VEHICLE (MSSV)	C	3	408	1224
Assembly:058867; SHORT DESC: TRK CARG 7T MIL	D	3	528	1584
Assembly:082655; SHORT DESC: TRLR 55T SEMI LOWBED DED HYDRAULIC REMOVABLE GOOSE	E	3	648	1944
		57		16,596

**Table 14311-3:
Net to Gross Table**

FROM	TO	NTG
0 SF	20,000 SF	1.35
20,000 SF	50,000 SF	1.2
50,000 SF	150,000 SF	1.15
150,000 SF	above	1.1

NTG: includes 2' perimeter lane along all walls and a 20' access lane.

	Total SF	16,596 SF
Add 250 SF for Mechanical Room (Fire sprinkler system)		250 SF
	NTG:	1.35
	Total:	22,742.10 GSF
	Say:	22,743 GSF

143 12 OPERATIONAL VEHICLE LAYDOWN AREA (SY)

FAC: 8523

BFR Required: Y

14312-1 **GENERAL.** Many Navy and Marine Corps operational commands have missions that require the acquisition, operation, and maintenance of various types of vehicles and equipment. Examples of these include Civil Engineering Support Equipment (CESE) and Service craft and Boat Accounting Report (SABAR) equipment. These items are typically acquired based on information shown in each command's Tables of Allowance and Equipment (TOA & E; Navy) or Table of Equipment (TE; Marine Corps) and are usually associated with an operational maintenance shop or motor pool. As a result, these commands have requirements for secure paved areas for

storing these vehicles and equipment. These areas are typically different from standard parking areas in that they require more robust parking surfaces and they are sized to accommodate vehicles and equipment that are infrequently used. This CCN is intended for long term storage of specialized vehicles and equipment only, and normal command staff parking should continue to be captured under CCN 85210 or similar.

14312-2 DEFINITION. An operational vehicle parking and/or laydown area consists of an asphalt or concrete paved area large enough to store and provide circulation for the vehicles and equipment for which the command is responsible. Vehicles can range from a typical passenger vehicle to a large prime mover such as an MTRV truck. The equipment requiring storage can range from towable generator sets or light packs to large flatbed trailers. It also includes operational small craft such as the in-shore fast boats and their trailers. These parking/laydown areas require perimeter fencing and in some case will require site lighting adequate enough to perform vehicle or small craft outfitting or minor repairs during night time hours. This category code should also be used to capture parking and maneuvering areas associated with CCN 15522 Small Craft Boat Ramp facilities (where the parking/laydown requirements are captured as a CCN14312 utilization on the associated boat ramp property record card).

14312-3 ALLOWANCE. Space allowances are based on engineering evaluations that summarize the size and quantity of each vehicle shown on the requesting command’s TOA. The process for determining overall requirements is as follows:

1. Using the “General Description” column in Table 14312-1 (see below), planners must determine the type code for each vehicle/equipment type being used by the command. In cases where the general description is unclear or doesn’t match that which is listed, use the actual item length and compare it to the “Size” column in the table to determine the type code.

Table 14312-1 Engineered Surface Laydown

Size	General Description	Type Code	GSY	GSF	*Net to Gross Factor
Small (<10FT)	Non-mechanized CESE and SABAR (ex: Fuel Water SIXCON, Motors, Pumps, Generators, TRICONS)	A	19	168	1.50
Medium (10FT-20FT)	Vehicles and non-mechanized CESE and SABAR (ex: Passenger Vehicles, HMMWV, Light Plant, Fork Lifts, Small Zodiac Boats)	B	32	288	1.75
Large (20FT-30FT)	Large CESE and SABAR (ex: MTRV, Fuel Trucks, Boats < 30FT)	C	46	408	1.75
Extra Large (30FT-40FT)	Extra Large CESE and SABAR (ex: Boats > 30FT, Scrapers, Water Well, Semi Trailers)	D	59	528	2.00
Extra Large (40FT-50FT)	Extra Large CESE and SABAR (ex: Boats > 40FT, Scrapers, Water Well, Semi Trailers)	E	72	648	2.00

Size	General Description	Type Code	GSY	GSF	*Net to Gross Factor
Extra Large (50FT-60FT)	Extra Large CESE and SABAR (ex: Boats > 50 FT, Semi Trailers, lowboy 55T)	F	86	768	2.25
Extra Large (60FT-70FT)	Extra Large CESE and SABAR (ex: 11M Rib with Prime Mover; 40PB with Prime Mover)	G	99	888	2.25

* Net to gross factor includes drive lanes/maneuvering areas, and circulation space around each item.

- When requirement is for covered laydown engineered surface, use the Covered Laydown (Table 14312-2). The area is determined by: Component length (based on table's Type Code) x NUMBER OF CESE for each item.

Table 14312-2 Covered Laydown

Type Code	Length (FT)
1A	5
A	10
1B	15
B	20
C	30
D	40
E	50
F	60

- Once the type codes are assigned for each item in the command's TO&A/TE, multiply the area allowances per each type (A through G) by the quantity of each type needed. The sum of the total areas for each type code is then the total area requirement for the parking/laydown area for the command's operational vehicles and equipment. This area includes circulation and maneuvering space.

NOTE: For parking/laydown areas associated with CCN 15522 Operational Boat Ramp facilities only: Determine the required area based on the average number of boat trailers, prime movers, and support vehicles/equipment to be parked on site during a typical training mission and use Table 14312-1 to determine a total gross area (same process as shown above). Add an additional 5% to this gross area to account for the prime mover/trailer combination maneuvering apron located adjacent to the boat ramp.

143 13 OPERATIONAL VEHICLE/EQUIPMENT CANOPY (SF)

FAC: 1459

BFR Required: Y

14313-1 **DEFINITION.** An operational vehicle/equipment canopy is used by the Navy and Marine Corps expeditionary units to protect vehicles and equipment from the weather. These canopies are usually associated with operational vehicle laydown areas or similar.

14313-2 **ALLOWANCE.** Sizing of these canopies is accomplished via an engineering analysis and is based upon the total area occupied by vehicles and/or equipment plus any related circulation between them. Note that canopies are measured by the drip line projected from the roof eaves down to ground level.

143 15 RANGE OPERATIONS CENTER (SF)

FAC: 1731

BFR Required: Y

14315-1 **DEFINITION.** A range operations center is the control point for testing torpedoes, calibrating ships' firing systems, and training pilots and testing aircraft on gunnery and bombing ranges. The center will vary with the equipment and control areas required. Standard planning factors for a center are not available. Its size must be planned to support the equipment and control areas to be housed.

143 17 SPACE SURVEILLANCE FACILITY (SF)

FAC: 1444

BFR Required: Y

14317-1 **DEFINITION.** Requirements are determined by Naval Network and Space Operations Command. Facilities typically support global space surveillance network which detects, tracks, identifies, and catalogs man-made objects in space and provides position information on these objects.

143 20 ORDNANCE OPERATIONS BUILDING (SF)

FAC: 1444

BFR Required: Y

14320-1 **DEFINITION.** An ordnance operations building is authorized where there is a need to control an ordnance operation. Ordnance operations are those involving ammunition storage, handling or disposal and organizational level maintenance. The facilities whose primary function is ordnance maintenance, intermediate level and above, are addressed in the 200 series Category Codes.

14320-1.1 **Installation Ordnance Operations Building.** At an ammunition storage or handling installation the authorized building space are 150 gross SF per person for administrative personnel and 50 gross SF per person for operating personnel (ammunition handlers, etc.). This provides space for an office (s), assembly and briefing room for ammunition handlers, locker room, and storage space for ammunition handling tools and equipment. Space requirements may increase as handling and support equipment changes dictate larger work and storage areas. Sufficient justification should support the increased space requirements. Air installations with bomb build-up requirements can plan for a weapons build-up facility. This facility serves as an ordnance assembly area for bombs, missiles and the like prior to going to the flight line for loading on aircraft. An overhead hoist, work tables

and several roll up doors are minimal requirements to promote the build up process. This facility can also serve to perform basic ordnance maintenance. Planning criteria is not available because of the potential multi-functions that may be served in this facility. Recommend a space analysis starting with a process flow and identifying functions to be performed.

14320-1.2 **Explosive Ordnance Disposal Facilities.** The EOD facilities have been moved to Category Codes 143 22, 143 23 and 143 24.

143 21 AMMUNITION SEGREGATION FACILITY (SF)

FAC: 1443

BFR Required: Y

14321-1 **DEFINITION.** A segregation facility is a building or series of buildings where fleet return explosive and inert material are screened and grouped by type and physical condition.

14321-1.1 Definition from NAVSEA OP-5 Vol. 1: Typically these functions are located at Naval Weapons Station or Naval Magazine installations. For these larger installations, there may be multiple segregation facilities for bomb-type ammunition, general ammunition and propellant powder buildings. At smaller ammunition installations there would be just one segregation facility. For additional information see the NAVSEA OP-5 Manual.

14321-1.2 No planning criteria exist for the segregation function; recommend an engineering evaluation be completed. Functional examples might be: Shipping /receiving, inspection area, banding area and a technical documents area, etc. Some questions that might be asked of the facility user interviews: What is approx. ordnance throughput (amount/time period) average? Peak? What types of ordnance? Containerized precision guided munitions may require large amounts of space versus palletized ordnance. Will explosives be left in facility overnight? NAVSEA OP-5 safety criteria will dictate requirements.

143 22 NAVY EXPLOSIVE ORDNANCE DISPOSAL SHORE DETACHMENT FACILITY (SF)

FAC: 1444

BFR Required: Y

14322-1 **DEFINITION.** the nature and scale of the EOD operations involved, billets will be assigned for a "shore detachment" (1 officer, 1 – Leading Chief Petty Officer (LCPO), and 7 enlisted personnel). The facilities defined below are sized to support an EOD Shore Detachment (DET) and includes the following: Operational Space – built to "Open Secret", armory – built to meet **OPNAVINST 5530.13C, Physical Security Instruction for Conventional Arms, Ammunition, and Explosives, Armory**, latest revision. Lobby/Quarter Deck, Operational Space, Locker/Shower room, and drying cages (climate controlled) will be in environmentally controlled spaces. Open Bay

spaces will include: 1) Workshop/Maintenance spaces, equipment storage, 2) exterior fresh water wash down area with deep sink, 3) drying area, and 4) four-bay High Bay Area Vehicle/ Boat Storage/miscellaneous emergency response equipment area. High Bay area must be provided with exhaust ventilation system and 16' x 16' roll-up doors. One bay, minimum, will be a "drive-through" to support the Multi-Mission Expeditionary Response Truck (MERT) and the trailer. To ensure correct line-up into the MERT bay, provide a straight approach lane, 58 feet x 16 feet, in front of and behind (for drive through lane) the facility for access.

Description	NSF	Climate Control	Net to Gross
Lobby/Quarter Deck			
Lobby and Sign In Area	165	Yes	1.35 to 1
Bunk Room	100	Yes	1.35 to 1
Male/Female Restroom for EOD Shore DET personnel	48	Yes	1.35 to 1
Provide a male/female restroom for lobby area	48	Yes	1.35 to 1
CONSTRUCT TO OPEN SECRET			
OPS (admin)	948	Yes	1.35 to 1
private offices - 2 ea: 200 SF, general office space – 7 ea: 448 SF Planning and Briefing Cell: 150 SF SIPER Room: 1 ea: 150 SF			
Male Restroom for EOD Shore DET personnel within the Open Secret Spaces	62	Yes	1.35 to 1
Female Restroom for EOD Shore DET personnel within the Open Secret Spaces	46	Yes	1.35 to 1
Shore DET PGI Cages			
9 ea @ 112 SF/cage	1,008	Yes	1.35 to 1
Shore DET Changing Room			
Male Bathroom/Shower/Locker Area	194.5	Yes	1.35 to 1
Female Bathroom/Shower/Locker Area	95	Yes	1.35 to 1
Drying Cages Area			
9 ea at 36 SF/cage (Drying Cages to be Climate & Humidity Controlled)	324	Yes	1.35 to 1
Armory			
(Armory must meet OPNAVINST 5530.13C, Physical Security Instruction for Conventional Arms, Ammunition, and Explosives, Armory requirements)			
General Armory Space for maintenance parts storage, safe, HazMat Locker, workbench, ect	433	Yes	1.35 to 1
Weapons and Case Storage	180	Yes	1.35 to 1

Description	NSF	Climate Control	Net to Gross
Communications Gear Storage			
Shelving (4 In ft x 2 ft deep and 4 In ft x 4 feet deep) for communications gear storage	65	Yes	1.35 to 1
OPEN BAY AREA			
Operational Storage			
Shore DET Operational Storage Cage Space (Section 10 material), 10' x 10'. Size based on 8' max stack height	100	No	1.35 to 1
TOA stored on shelving units - Section 47: 32 sf plus 2.25 clearance factor(BDY ARMR EOD/LG)	72	No	1.35 to 1
Open floor space for items too heavy to store on shelving	538	No	1.35 to 1
TOA Storage (items not in Cage, on shelves, or on floor), Total Cubic Foot	975	No	1.0 to 1
Note: Net to Gross built into the GSF calculation for TOA storage			
Miscellaneous Work Areas			
Maintenance Work Benches, 2 ea	108	No	1.15 to 1
Wet Charging Stations, 2 ea - 2' x 6'	54	No	1.15 to 1
2 ea dip tanks located near exterior wall to be connected to Shore DET Air Compressor located near exterior wall under cover)			
Shore DET Open Area for Misc functions			
12 sf/EOD Tech	96	No	1.15 to 1
CESE/SABAR Storage			
Four Bays; Bays to be 68' deep X 16' wide with a 16' x 16' bay opening	4,352	No	1.15 to 1
Note: Provide at least One bay with drive through capability			
EXTERIOR SPACES/FUNCTIONS			
Exterior Rinsing Station			
Outside showers and wash sink is required. Provide 4 Showers, 1 stainless steel sink, 8' W x 4' deep and appropriate screening for outdoor gear washing.	108	No	1.10 to 1
Equipment Wash Tank, 2 ea, 6' L x 2' W	27	No	1.10 to 1
Temp exterior drying cage area (equipment/material staging/drying racks/shelving), 6 each, 3' x 4', cage spaces	162	No	1.10 to 1

Description	NSF	Climate Control	Net to Gross
Covered area outside of DET facility High Bay area for the DET's air compressor. Area to include cover from weather and piping, certifiable to Breathing Air standards and routed into the DET's Wet Charging station inside the High Bay space.	25	No	1.10 to 1

14322-2 In addition to the EOD shore detachment building proper, there are supporting facilities, which are located separately to meet safety requirements. This square footage is not part of this CCN and, therefore a separate BFR must be submitted for this requirement. The EOD Shore DET will require either a Golan or Ready Service Locker, both equipment, to house small quantities of explosives. This equipment must be mounted on an Explosive Storage Site Pad, CCN 425-11, and the Explosive Storage Site Pad will be sited In Accordance With Naval Ordnance Safety and Security Activity (NOSSA) Instruction 8020.22 (latest revision). The Shore DET will need an Ordnance Demolition Area for destroying explosives and explosives-loaded devices, see CCN 148-20. Include an Observation Tower/Bunker for the protection of the EOD Shore DET personnel, CCN 173-40, to support the Ordnance Demolition Area. The Shore DET will need space for a generator to support Intrusion Detection System (IDS) requirements for AA&E/Classified Storage. Provide a Miscellaneous Open Storage Pad, CCN 852-40. Size the pad in accordance with the size of the backup generator plus a clearance area of 3 foot minimum on all sides of the generator to accommodate facility maintenance. The generator is equipment, and therefore must be provided by the command. In situations where the Shore DET requires a boat ramp and pier space, add CCNs 143-12, 155-20 and 155-22.

14322-3 **EOD Shore Detachment Facility:**

EOD Shore DET Building	CCN 143-22: 12,032 GSF
Additional Requirements:	
Operational Vehicle Parking/ Laydown Area	CCN 143-12: 338 GSY
Explosive Storage Site Pad	CCN 425-11: Sized to requirement
Ordnance Demolition Area	CCN 148-20: Sized to requirement
Observation Tower/Bunker	CCN 173-40: Sized to requirement
Backup Generator	CCN 852-40: Sized to requirement
Boat Ramp	CCN 155-22: 1 ea
Small Craft Berthing	CCN 155-20: 89 FB, 2,250 SF
POV Parking	CCN 852-10: Sized for 9 personnel plus 2 visitor parking spaces

**143 23 NAVY EXPLOSIVE ORDNANCE DISPOSAL MOBILE UNIT (EODMU)
FACILITY (SF)**

FAC: 1444

BFR Required: Y

14323-1 **DEFINITION.** EODMUs are responsible for manning, equipping and training of any number of deployable EOD detachments: Mobile Detachments, Area Search Detachments, Ordnance Clearance Detachments, Mobile Communications Detachments, Combat Service Support Detachments, Fly Away Recompression Chamber Detachments, Mine Counter Measures Detachments and Marine Mammal System Detachments. Facilities are required for administrative activities, equipment maintenance and storage, training and operations. Manning levels vary by MU, so square foot requirements for a given installation is based on the following criteria, all SF are net (NSF):

14323-1.1 **Net to gross markups by functions:**

- Administration through bath/showers functions below: 1.25
- Training Spaces: 1.33
- Supply/Storage: 2.38
- Remainder, operational spaces: 1.33

14323-1.2 **Administrative spaces:** 120 SF per administrative worker (includes CO, XO, CMC, MAA and all administrative department personnel).

14323-1.3 **Classified equipment and documents area:** 300 SF plus an additional 25 SF for each detachment assigned for the storage and maintenance of classified documents and equipment.

14323-1.4 **Quarterdeck:** Allow 150 SF for security screening area.

14323-1.5 **Bunkroom:** Allow 72 SF for each member of the watch. Separate male and female bunkrooms required.

14323-1.6 **Bathrooms/Showers:** Allow 15 SF/water closet, 20 SF/shower, 6 SF/urinal and 6 SF/lavatory with the number of fixtures appropriate for the maximum number of personnel using the facility at one time.

14323-1.7 **Multi-purpose Training/Conference Room:** Use Category Code 171-10, General academic. Loading is based upon an all-hands function, the mobile unit and all assigned detachments.

14323-1.8 **Academic Instruction Space:** Use Cat Code 171-10, General academic. Allow for instructor(s) space.

14323-1.9 **Supply/Storage:** Allow 2,100 SF for spare parts storage and 450 SF of administrative area for supply functions. The administration area should use the admin. net to gross markup above.

14323-1.10 **Magnetometer Room:** Allow 360 SF for testing of special purpose low magnetic signature tools.

14323-1.11 **Compressor Room:** Allow 300 SF for divers fixed high-pressure compressor and flasks.

14323-1.12 **Hydro Room:** Allow 300 SF for hydro test equipment.

14323-1.13 **MK 16 Locker:** Allow 800 SF for maintenance and preparation of MK 16 diving equipment. This needs to be an O₂ clean room.

14323-1.14 **Communal Staging Area.** Allow 1,000 SF for a communal outdoor staging area for assigned mobile detachments. Used prior to deployment for gear inspection and preventive maintenance.

14323-1.15 **Electronics Shop.** Allow 400 SF for maintenance of communications and navigation equipment.

14323-1.16 **Personnel Lockers.** Allow 12 SF for each diver and 6 SF for each additional support person assigned.

14323-1.17 **Medical Area.** Allow 150 SF for a doctor or independent duty corpsman (if both, 150 each), 200 SF for an examining room and 150 SF for a waiting area/medical records office.

14323-1.18 **Scuba Locker:** Allow 1350 SF for maintenance and preparation of scuba diving equipment.

14323-2 **Spaces.** The unique detachment missions may dictate additional spaces. The different type of EOD detachments and their space requirements that may be assigned to the Mobile Units are listed below. The typical manning levels are provided; should additional space be required, it must be individually justified.

14323-3 **Area Search Detachment (ASD):** Allow 450 SF for equipment storage and maintenance and 150 SF of administrative area for each ASD assigned. Manning: 1 Off/ 7 Enl.

14323-4 **Combat Service Support Detachment (CSSD):** Allow 1,200 SF for administrative, 6,000 SF warehouse for material and equipment storage and 3,968 SY controlled outside equipment lay down storage. Manning: 1 Off/ 16 Enl.

14323-5 **Fly Away Recompression Chamber Detachment (FARC):** Allow 1,204 SF for administrative, supply and equipment storage and 90 SY lay down compound for (1) FARC, (1) Generator set and (1) 8' x 8' x 10' Milvan. Manning: 1 Off/ 5 Enl.

14323-6 **Marine Mammal System Detachment (MMS):** Allow 1000 SF for each Mark shop assigned (e.g. Mk 5). Allow 432 SF for veterinarian. Allow 800 SF for food preparation. The Marine Mammal Systems Managers will determine space requirements for holding pens, staging areas and Marine Mammal Management Facilities. These spaces are regulated by Federal regulations and standards. Manning: 1 Off/ 15 Enl.

14323-7 **Mine Counter Measures Detachment (MCM):** Allow 1700 SF for equipment storage and maintenance and 150 SF for administrative area for each MCM detachment assigned. Manning 1 Off / 7 Enl.

14323-8 **Mobile Communications Detachments (MCD):** Allow 1,850 SF for equipment storage and maintenance and 150 SF of administrative area for each MCD assigned. Manning: 1 Off/ 7 Enl.

14323-9 **Mobile Detachments (MOB):** Allow 800 SF for equipment storage and maintenance and 150 SF for administrative area each mobile detachment assigned. Manning: 1 Off/ 7 Enl.

14323-10 **Ordnance Clearance Detachments (OCD):** Allow 480 SF for equipment storage and maintenance. Allow 150 SF of administrative area for each OCD's assigned to the mobile unit. Manning: 1 Off/ 7 Enl.

14323-11 **Additional Functions.** Additional functions associated with EOD units/detachments are mission driven and must be individually justified. The following Category Codes are some applicable selections:

- Parachute Survival Equipment Shop: use Category Code 211 75.
- Small Craft Fuel Station: use Category Code 122 20.
- Small Craft Fuel Storage Area: use Category Code 122 30.
- Emergency Vehicle Garage: use Category Code 143 10.
- Operational Vehicle Garage: use Category Code 143 11.
- Operational Storage: use Category Code 143 77.
- Armory: use Category Code 143 45.
- Hazardous Material/Flammable Storage: use Category Code 143 78.
- Ordnance Demolition Area: use Category 148 20.
- Small Craft Berthing: use Category Code 155 20.
- Landing Craft (boat) Ramp: allow one EA under Category Code 159 66.
- Light Demolition Range: use Category 178 30.
- Boat Shop: use Category Code 213 58.
- Vehicle Holding Shed: use Category Code 214 40.
- Vehicle Shop: use Category Code 214 20.
- Ready Magazine: use Category Code 421 35.
- Open Storage Area: use Category Code 451 10.
- Parking Area: use Category Code 852 10.

143 24 MARINE CORPS EXPLOSIVE ORDNANCE DISPOSAL FACILITY (SF)
FAC: 1444
BFR Required: Y

14324-1 **DEFINITION.** These facilities provide support for Marine Corps EOD shore teams and platoons permanently assigned to Marine Corps installations. The manning structure for EOD teams and platoons has increased and is reflected below in category codes 143 24 and 143 26.

14324-2 This facility provides support for EOD operations on Marine Corps Bases, Marine Corps Air Stations, and Marine Corps Air Wing Support Squadrons. The facility defined below is scaled to match the EOD Team (1 Officer, 8 Enlisted) and include administrative spaces, classified publication vault, quick response ready lockers, workshop/maintenance space, classroom, equipment storage, locker room, and ordnance training aids library space. The facility will be equipped with an Intrusion Detection System (IDS). In addition, the facility will house all the emergency response vehicles, trailers (including total containment vessels), and other emergency response equipment.

14324-3 In addition to the EOD team facility proper, there are supporting facilities, which are located separately to meet safety requirements. The hazardous/flammable storage building, category code 143 78, stores petroleum products, petroleum operated equipment, corrosives, and paints. Typically these building are 12'x17', but larger sizes may be justified depending on the team's operational mission. This building should be located as close the EOD building as safety standards permit. The other facilities are the ready service magazines and are described under category code 421 35 as "Ready Magazines". Refer to category code 421 series to understand the unique storage requirements of ordnance. These are sited in accordance with safety criteria published in NAVSEA OP 5, Volume 1, "Ammunition and Explosives Ashore" (abbrev. Title).

14324-4 When multiple EOD teams are assigned to the same installation and when collocating teams is viable, the gross square below should be multiplied by the number of teams assigned. Overall square footage may be reduced for common use spaces.

Table 14324-1
Overall Square Footage Requirements
For EOD Teams

EOD Building	7000 GSF
EOD Haz/Flam Building	204 GSF or sized to requirement
EOD Ready Service Magazine	Sized to requirement

14324-5 Submitted basic facility requirement (BFR)s shall include the EOD Table of Organization for the installation supported and facility component breakdowns of the overall requirement (i.e. admin, vehicle/trailer housing, storage, publication vault, locker area, etc).

143 25 SEAL TEAM BUILDING (SF)**FAC: 1444****BFR Required: Y**

Note: This Category Code contains assets that were previously classified under 143 28.

14325-1 **DEFINITION.** The requirements for these facilities are developed by an industrial analysis for the specific facility. See category code 610 10 for administrative space guidelines and category code 159 64 for Waterfront Operations Building guidelines.

143 26 MARINE CORPS EXPLOSIVE ORDNANCE DISPOSAL COMPANY FACILITY (SF)**FAC: 1444****BFR Required: Y**

14326-1 This facility is necessary for manning, equipping, and training for EOD operations in support of Fleet Marine Forces (FMF). The facility organization components below are scaled to match the EOD Company (10 Officers, 99 Enlisted), which incorporates 7 EOD Sections (1 Officer, 12 Enlisted), an Operations and Training Unit (1 Officer, 12 Enlisted), and a Headquarters (2 Officers, 3 Enlisted). Additionally, standalone FMF EOD sections can scale their requirements to the listed criteria. Facilities are required for administration, equipment maintenance and storage, training, and operations. All square footage criteria are in Net Square Feet (NSF). The Net-to-Gross conversion to calculate Gross Square Feet (GSF) is 1.4.

14326-1.1 Headquarters and Operational and Training Unit

Administrative Space. Allow 1,910 SF for administrative functions; this includes Company Commander, Company Executive Officer, EOD Chief, First Sergeant, Operations Officer, Operations Chief, and all other administrative department personnel.

14326-1.2 **Secure Waiting Area.** Allow 120 SF for security screening and visitor waiting area.

14326-1.3 **Conference Room.** Allow 240 SF for meetings with section operations and training and headquarters leadership. Conference room requires the capability to conduct classified discussions.

14326-1.4 **Classified Publications Vault.** Allow 811 SF for storage of classified material and administrative space. This space requires Intrusion Detection System (IDS) and all current physical security requirements outlined in Marine Corps Order (MCO) 5530.14A "Marine Corps Physical Security Program Manual."

14326-1.5 **Bathrooms/Showers.** Allow 15 SF/water closet, 20 SF/shower, 6 SF/urinal, and 6 SF/lavatory with the number of fixtures appropriate for the maximum

number of personnel using the facility at one time. Allow 200 SF for female bathroom/shower area.

14326-1.6 **Multi-Purpose Classroom.** Use Category Code 171 10, Section 17110-1.1 "General Academic Classroom for determining the space requirements. This type of classroom requires the capability to allow for classified briefings and EOD reporting discussions. The loading is based upon an all-hands function or the maximum of 100 students.

14326-1.7 **Communal Staging Area.** Allow 1,000 SF for a communal outdoor staging area for assigned detachments. This staging area is for use prior to deployment and supports gear inspections and preventative maintenance. Provide a paved area at a minimum.

14326-1.8 **Training Aids Library.** Allow 2,000 SF for this type of library, which is used to store/display inert training aids. Space allocation is for a standalone EOD section, company, or combined facility.

14326-1.9 **Break Area.** Allow 811 SF for a break area. Space allocation is for a standalone EOD section, company, or combined facility.

14326-1.10 **Material and Equipment Work Area.** Allow 2,400 SF for spare parts storage, expendable equipment, and unassigned company table of equipment.

14326-2 **Explosive Ordnance Disposal Section.** This section requires additional space for each EOD unit of action. Allocate 1,200 SF for administration area and 2,400 SF for material, equipment, and maintenance area for each EOD section. The manning level for each EOD section is 1 Officer and 12 Enlisted personnel.

14325-2.1 **Personnel Lockers.** Allow 18 SF per person for the maximum number of personnel using the facility at one time. The size of the facility is to accommodate all the necessary combat equipment that each EOD section member is assigned.

14326-3 **Exploitation Facility.** The exploitation facility must be associated directly with an "Ordnance Demolition Area" under Category Code 148 20 and/or "Light Demolition Range" under Category Code 178 30. The exploitation facility supports both training and operational taskings to satisfy mission requirements. Use the following category codes for reference:

- 143 21 Ammunition Segregation Facility
- 216 10 Ammunition Rework and Overhaul Shop

14326-4 **Marine Corps EOD Divers - EOD Dive Officers – Littoral Explosive Ordnance Neutralization (LEON) Capable EOD Sections.** The requirements are listed below:

14326-4.1 **Magnetometer Room:** Allow 360 SF for testing of special purpose low magnetic signature tools.

14326-4.2 **Compressor Room:** Allow 300 SF for divers fixed high-pressure compressor and flasks.

14326-4.3 **Hydo Room:** Allow 300 SF for hydro test equipment.

14326-4.4 **MK 16 Locker:** Allow 800 SF for maintenance and preparation of MK 16 diving equipment. An O₂ clean room is required to support maintenance and preparation.

14326-4.5 **Scuba Locker:** Allow 1,350 SF for maintenance and preparation of scuba diving equipment.

14326-4.6 **Fly Away Recompression Chamber (FARC):** Allow 1,204 SF for administrative, supply and equipment storage and 90 SY for laydown compound to support 1 FARC, 1 generator set, and 1 (8' x 8' x 10') Milvan.

14326-4.7 **Additional Equipment Storage and Maintenance:** Allow 1,700 SF for equipment storage and maintenance per LEON capable EOD section.

14326-5 **General BFR Guidelines.** Submitted Basic Facility Requirements (BFRs) will include the EOD Table of Organization and Equipment for the installation supported and facility component breakdowns of the overall requirement (i.e. admin, vehicle/trailer housing, storage, classified publication vault, locker area, etc.).

14326-6 **Additional Category Code Functions.** Additional functions associated with EOD company/sections are mission driven and must be individually justified. The following category codes illustrate these additional functions:

- Small Craft Fuel Station: use Category Code 122 20.
- Small Craft Fuel Storage Area: use Category Code 122 30.
- Emergency Vehicle Garage: use Category Code 143 10.
- Operational Vehicle Garage: use Category Code 143 11.
- Armory: use Category Code 143 45.
- Operational Storage: use Category Code 143 77.
- Hazardous Material/Flammable Storage: use Category Code 143 78.
- Ordnance Demolition Area: use Category 148 20.
- Small Craft Berthing: use Category Code 155 20.
- Landing Craft (boat) Ramp: allow one EA under Category Code 159 66.
- Light Demolition Range: use Category 178 30.
- Parachute Survival Equipment Shop: use Category Code 211 75.
- Boat Shop: use Category Code 213 58.

- Vehicle Shop: use Category Code 214 20.
- Vehicle Holding Shed: use Category Code 214 40.
- Ready Magazine: use Category Code 421 35.
- Open Storage Area: use Category Code 451 10.
- Parking Area: use Category Code 852 10.

143 35 REGISTERED PUBLICATIONS ISSUING OFFICE (SF)

FAC: 1444

BFR Required: Y

14335-1 **DEFINITION.** A Registered Publications Issuing Office (RPIO) has a primary mission of supporting communications operations of the Fleet, Naval Aviation, U.S. Marine Corps, and the U.S. Coast Guard. RPIO's receive, store, issue, account for, and-officiate during the destruction of highly classified cryptological publications, equipment, and devices circulating in the Registered Publications System (RPS). An RPIO has three major space areas: Storage, Receive/ Issue, and Administration. The storage area of the RPIO must be constructed to meet the criteria of a Class A vault as defined in KAG-1D. The size of an RPIO can generally be related to the number of RPS items handled yearly. RPS items are such things as publications, magnetic tapes, films, crypto equipment, spare parts, cards, and other key material. See Table 14335-1 for planning factors.

**Table 14335-1. Space Allowances
Registered Publications Issuing Office**

RPS Items Handled Per Year (Thousands)	Gross Area (SF) Admin, Receive/Issue, Vault
100 - 500	7,500
501 - 750	12,500
751 - 1,250	14,000
1,251 - 2,500	16,000

143 40 COMPUTER PROGRAMMING OPERATIONS CENTER (SF) [DELETE]

FAC: 6104

BFR Required: Y

14340-1 This category is deleted. All future requirements should be reassigned and revised to Category Code 13115 "Communications, Information, or Intelligence Analysis Facility".

143 41 AMPHIBIOUS OPERATIONS BUILDING (SF)

FAC: 1431

BFR Required: Y

14341-1 The requirements for these facilities are developed by an industrial analysis for the specific facility. See category code 610 10 for administrative space guidelines and category code 159 64 for Waterfront Operations Building guidelines.

143 45 ARMORY (SF)

FAC: 4427

BFR Required: Y

14345-1 **DEFINITION.** A Navy installation armory provides space for storage and routing maintenance of small arms and emergency gear. The materials stored will provide for emergencies and for training of selected personnel in the handling of station emergencies, civil disorders, and area disasters. See Table 14345-1 for space allowance.

Table 14345-1. Armory

Installation Military Strength	Building Gross Area
up to 2,000	576
2,001 - 4,000	880
4,001 - 7,500	1,200
7,501 - 10,000	1,508
Over 10,000	Add 0.1 sq ft per person

14345-2 The space above provides for an armory and small arms shop supporting only the weapons and personnel assigned to that installation. See Category Code 215 10 for Small Arms Shop in support of multiple installations.

14345-3 An additional method is to build the space requirements by weapon and ammunition count. The weapons/equipment within the armory is typically stored within cabinets, gun racks, shelving, boxes, or wall boards. In most cases, this method of storage allows some stacking of the weapons/equipment which can reduce floor space requirements. Requirements are listed on the Marine Force Armory website. Go to the "input" worksheets for: terms, definitions, weapon storage dimensions and basic algorithms for different types of weapons and equipment. Use this information to calculate space requirements.

14345-4 Armory design specifications can be found in MIL-HDBK-1013/1A and additional policy and guidance in OPNAVINST 5530.13 Series, Fleet Marine Force Armory (SF).

14345-5 An armory for Fleet Marine Force air and ground units provides a humidity controlled, air conditioned and secure space for storing and maintaining weapons assigned to personnel. Consolidation of unit armories should be emphasized provided such action is compatible with mission requirements, responsiveness and accessibility.

14345-6 The SF allocation for the Marine Force armory can be determined by locating the P-80 on the NAVFAC portal. The criteria algorithm is an EXCEL spreadsheet with the instructions provided in the first worksheet. Once the spreadsheet is opened go to the “instructions” worksheet.

14345-7 If you intend on using the spreadsheet to calculate facility requirements, it is suggested you perform a “save as” function to operate the spreadsheet from your computer vice via the Internet.

Click [here](#) to go to the spreadsheet.

143 46 MARINE BARRACKS - GENERAL PURPOSE BUILDING (SF)

FAC: 1446

BFR Required: Y

14346-1 **DEFINITION.** The criteria contained herein are applicable to CNO commanded Marine Barracks. The purpose of the Marine Barracks is to provide such security as approved by the Chief of Naval Operations, in coordination with the Commandant of the Marine Corps, and to perform such additional functions as directed by CMC.

14346-2 The criteria for Marine Barracks cover general-purpose functions only (for example, administration/operational, general instruction, armory and supply). Requirements for specific functions such as shop space, specialized storage, etc., should be developed from criteria of the Category Code for the specific function. This criterion does not include BEQ or community support facility requirements. Planning factor criteria for BEQ and community support facilities necessary to support the Marine Barracks personnel are contained in the Category Codes series 700. However, under normal conditions, the host activity would be expected to provide all community type support.

14346-3 The following shall be utilized for broad planning purposes when there is an absence of a detailed analysis of functional requirements. Provisions for parking (Category Code 852 10) and small arms pyrotechnic magazine (Category Code 421 48) should utilize the appropriate Category Code.

Table 14346-1 Marine Barracks

Military Strength	Gross SF/MN
1-50	75
51-100	65
101-150	55
151-200	45
201 -	For every man over 200, add 30 gross square feet per man

143 47 ALERT FORCE BUILDING (SF)**FAC: 1446****BFR Required: Y**

14347-1 **DEFINITION.** An Alert Force Building is programmed in conjunction with an Air/Underwater Weapons Shop, Category Code 216 55, when required to meet the Alert Force response times established for the shop. The Alert Force Building provides barracks facilities, including limited messing facilities necessary to accommodate the guard of the day for an AUW Shop. It also contains a duty office, provision for weapons storage and an alarm repeater panel. Space requirements should be generated by an engineering space analysis.

143 55 TRANSIT SHED (SF)**FAC: 1444****BFR Required: Y**

14355-1 **DEFINITION.** A transit shed is planned to support the rapid and orderly transfer of truck and rail freight in shipment from one carrier to another with minimum storage. For a waterfront transit shed, see Category Code 156 10. The transit shed is of the minimum design that will protect the freight from the weather and provide any security necessary. It may be a roofed shed with open sides or completely enclosed space built to the minimum specifications to provide the required protection. Plan at the rate of 1500 SF per 64 measurement tons (MT) of throughput per day for a peak (assumes 4 FT high stacking, 12 FT aisles for equipment maneuvering)

143 60 EXPLOSIVES, SHIPPING/TRANSFER DEPOT (SF)**FAC: 1431****BFR Required: Y**

14360-1 **DEFINITION.** An explosives transfer depot is a facility used to transfer break-bulk ammunition and explosives between automotive vehicles and railcars for further shipment, or for delivery to a storage magazine, loading building, waterfront or

airfield. The transfer depot may be in close proximity to a loading platform, a flight line, or a truck or rail center. This facility is typically required only at installations which expend or transship the ordnance materials in large quantities, e.g. NAVWPNSTAs and NAVMAGs. No planning factors are available; however, consider using industry metrics like peak daily throughput in sf/ton per unit of time. This code is not to be used for containerized ordnance; for ordnance moved in ISO (International Standards Organization) containers, use Category Code 148 40, Container Transfer Facility (Ordnance) should be used.

143 65 REGION/INSTALLATION OPERATIONS CENTER (SF)

FAC: 1431

BFR Required: Y

14365-1 **DEFINITION.** A Region/Installation Operations Facility is a shore mission specific Command, Control, and Coordination (C3) area in direct support of the operations mission of a Region/Installation Navy or Marine Corps Activity. This facility can also be designated as a Regional Operations Center (ROC), Emergency Control Center (ECC), or Emergency Action Center (EAC).

14365-2 **FUNCTIONAL AREAS.** This facility may contain the following functional areas:

- Equipment areas for both classified and unclassified server spaces to support tactical and operational communications systems and networks
- Operations areas to include a Watch Center and a Command Viewing Area
- Operations Analysis Workstations and Special Access Programs (SAP) area

Additional space may be provided to support Special Purpose Spaces such as: Break Room, Conference Room, and a Duty/Bunk Room, as well as Private and Open Office areas to support the small day-to-day operating staff. Additionally, adequate facilities are required to accommodate all operations staff that man the facility during emergency operations. Additionally, due to the nature of the mission of these facilities, an Uninterruptible Power Supply (UPS) system and emergency generator system may be required. See Table 14365-1 for authorized functional areas. An Engineering Evaluation will be used to determine the quantity and type of functional areas required. Please refer to the guidelines provided in the introduction of 131-series Category Codes for C5ISR buildings to calculate the requirement for each functional area. Per section 131-14, the authorized **net-to-gross** factor is 1.45.

14365-3 **BUILDING BLOCKS.** Figure 14365-1 provides a diagram demonstrating a summary of the applicable spaces, appropriate allocation factors, and the special relationship for Region/Installation Emergency Operations Facilities.

Table 14365-1. Region/Installation Operations Facility Functional Areas

Functional Area	Sub-space	143 65
Administrative General Purpose	Private Office	J
	Open Office (Cubicle)	A
Special Purpose Space Basic	Admin Support	A
	Break Room	A
	Classified Vault	J
	Conference Rooms/VTC	A
	Duty/Bunk Room	J
	Technical Publications Area	J
Special Purpose Space Fitness/Locker/ Shower	Locker Room	J
	Shower Room	J
Special Purpose Space Security	Quarterdeck/Entry Control	J
	Special Security Office	J
Operations Space	Watch Center	A
	Analysis Operations	A
Equipment Space	Data Center/Server	A
	Communications Security Material Area	J

Legend:

A – Approved without additional justification (based on the staffing and mission requirements)

J – Only approved with specific justification of mission requirements

Figure 14365 -1. Region/Installation Operations Facility Building Blocks Diagram

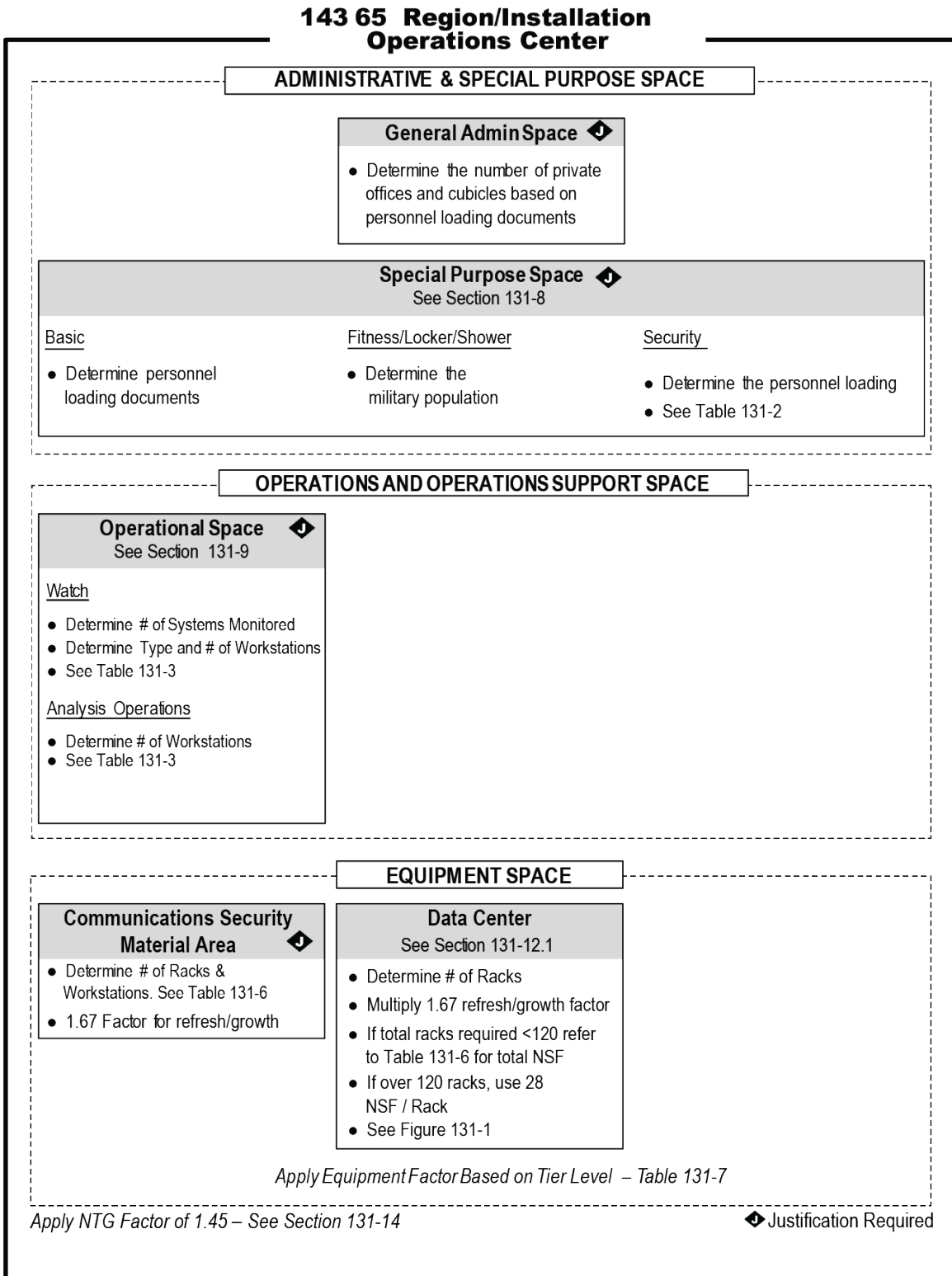

143 70 RADIATION INSTRUMENT CALIBRATION FACILITY (SF)**FAC: 1442****BFR Required: Y**

14370-1 **MONITORING DEVICES.** A health physics calibration building contains facilities required for calibration of health physics survey instruments and area monitoring devices. These devices are used to protect personnel against ionizing radiation from x-rays and atomic particles. The size of the building will depend upon the type and number of instruments being calibrated. Requirements typically include the following:

14370-2 **ADMINISTRATIVE OFFICES.** Refer to Category Code 610 10 guidance to determine the space requirements based on the number of offices needed.

14370-3 **CALIBRATION LAB.** Space consists of electrical and non-electrical workbenches, tool cabinets, and library of technical manuals, safety equipment, and storage of equipment waiting for calibration, storage for repair parts, and file storage for record keeping. The number of workbenches and cabinets must be determined based on the number of instruments being calibrated and number of personnel assigned to this function.

Table 14370-1. Calibration Lab

Items	NSF
Workbench (each)	125
Tool cabinet (each)	15
Library for manuals	50
Safety equipment	20
Equipment waiting calibration	80
Replacement parts	200
File storage cabinet (each)	7

14370-4 **Range.** Space consists of area to safely test the survey and monitoring equipment. The requirements will be determined by an engineering evaluation. The number of instruments, frequency of testing, and specific instrument testing requirements will dictate the space required for the range.

143 75 POL OPERATIONS/SAMPLING/TESTING BUILDING (SF)**FAC: 1442****BFR Required: Y**

14375-1 **DEFINITION.** The POL operation building provides space required for quality control and administration of fuel activity. Space is provided in the building for an administrative office, control/gauge monitoring center, and fuels testing laboratory. Physical operation and control of the fuel system will be accomplished elsewhere (such

as the pump house). Each person not working in the lab should be assigned desk space not to exceed 162.5 GSF. This gross area allows for wall thickness, corridors and other general circulation, mechanical rooms, and rest rooms. Supervisor may be provided with private offices. The lab area and control monitoring center requirements will be based on engineering field analysis of the spaces. For the lab and control center only, a net-to-gross multiplier of 1.45 may be used. This multiplier will account for wall thickness, corridors, and circulation around equipment, mechanical rooms, and rest rooms.

143 77 OPERATIONAL STORAGE (SF)

FAC: 1443

BFR Required: Y

14377-1 **DEFINITION.** Operational Storage supports multiple Departments/Divisions within a command. It is under the control of the Logistics and Supply Department. This Category Code is used to identify areas used for bulk storage areas of major end items, and operational material. Storage of material under the control of the Communications Department should be classified within Category Code 217 77.

14377-2 Storage facilities for equipment related to operational facilities will be provided only where it can be individually justified. There are no criteria for this type of facility. General information on normal stacking heights, SF per measurement ton requirements, and other parameters are provided in Category Code 440 series.

143 78 OPERATIONAL HAZARDOUS/FLAMMABLE STORAGE (SF)

FAC: 1443

BFR Required: Y

14378-1 **DEFINITION.** This category will be used to provide a facility for the storage of materials used in daily operations that require special environmental separation. These materials such as paint, acetone, oil, etc. are considered to be hazardous and/or flammable. Personnel or storekeeper that may be assigned to this facility should be provided with a separate office space not to exceed 162.5 NSF. An engineering field analysis will be required to determine the warehouse space based on quantity of materials stored. Racks or shelves will be used to reduce footprint. Some materials may not be mix or must be divided by berms or firewalls and this separation space should be added to calculations. These facilities may require some environmental controls and ventilation. If quantity is palletized allow for forklifts in aisle ways or access through overhead doors. Reference the 440 series for assistance on converting CF to NSF.

14378-2 Facility should be close to or an extension of other warehouse space, therefore other personnel support spaces (i.e., restrooms, break area, lockers, etc.) are not required. Operational commands store small quantities of materials and small facilities under 1000 NSF are typical. For hazardous waste, see category codes 831 41/42.

143 80 MISSION OPERATION COMMAND AND CONTROL FACILITY (SF)**FAC: 1404****BFR Required: Y**

14380-1 **DEFINITION.** A Mission Operation Command and Control Facility is a specialized facility that is only required in select locations to support the operations of Force Commanders and Fleet Commanders (e.g. US Fleet Forces Commander, Pacific Fleet) and selected others as established by DoD. A Mission Operation Command and Control Facility may also contain facility requirements for Type Commands (e.g. AIRLANT, SUBPAC), Operational Support Commands (e.g. CTF and CTG) and a Maritime Operations Center (MOC).

14380-2 **SPECIALIZED REQUIREMENTS.** A Mission Operation Command and Control Facility contains the total requirements for office space, special purpose space, operations spaces, maintenance spaces, training spaces, equipment space, and limited IT logistics support space. The technical and operational mission of this facility may require that it contain: Secure Compartmented Information Facility (SCIF) areas, an Uninterruptible Power System (UPS), emergency generator system and in select cases, TEMPEST countermeasures may be required such as Radio Frequency (RF) shielding, Protected Distribution Systems (PDS), and signal/power line isolation and filters. Although a Communications, Information, Intelligence Facility (Category Code 131 15) and/or a Satellite Communications Facility (Category Code 131 24) may be collocated on station with a Mission Operation Command and Control Facility, the Mission Operation Command and Control Facility may contain dedicated communication architecture and operational systems that require it to have its own connectivity via direct satellite systems.

14380-3 **FUNCTIONAL AREAS.** This facility may contain the functional areas outlined in Table 14380-1. In instances where Type Commands (e.g. AIRLANT, SUBPAC) and Operational Support Commands (e.g. CTF or CTG) are collocated with the operating force within the Mission Operation Command and Control Facility, a separate analysis shall be calculated for each respective command to determine their specific requirements. An Engineering Evaluation will be used to determine the quantity and type of functional areas required. Please refer to the guidelines provided in the introduction of 131-series Category Codes for C5ISR buildings to calculate the requirement for each functional area. Per section 131-14, the authorized **net-to-gross** factor is 1.45.

14380-4 **BUILDING BLOCKS.** Figure 14380-1 provides a diagram demonstrating a summary of the applicable spaces, appropriate allocation factors, and the special relationship for Mission Operation Command and Control Facilities.

Table 14380-1. Mission Operation Command and Control Facility Functional Areas

Functional Area	Subspace	143 80
Administrative General Purpose	Private Office	A
	Open Office (Cubicle)	A
Special Purpose Space Basic	Admin Support	A
	Break Room	A
	Break Room Kitchen	J
	Classified Vault	J
	Conference Rooms/VTC	A
	Duty/Bunk Room	J
	Mail Room	J
	Technical Publications Area	J
Special Purpose Space Fitness/Locker/ Shower	Fitness Room ¹	J
	Locker Room	J
	Shower Room	J
Special Purpose Space Security	Quarterdeck/Entry Control	A
	Special Security Office	J
Operations Space	Watch Center	A
	Analysis Operations	A
Maintenance Space	Maintenance	J
Training Space	Training	J
IT Logistics Support Space	IT Logistics Support Space	A
Equipment Space	Data Center/Server	A
	Commercial Services Equipment	J
	Communications Security Material Area	J
	Network Distribution Area	J
	Specialized Equipment	J

Legend:

A – Approved without additional justification (based on the staffing and mission requirements)

J – Only approved with specific justification of mission requirements

(1). This requirement should be captured under CCN 740 45. Fitness Rooms are only allowed in accordance with CNICINST 1710.1 where by the command is located more than a 15- minute commute by vehicle from the nearest Morale Welfare and Recreation (MWR) Fitness Center, or in cases where service members are required to be on station and unable to leave for 18 hours at any given time. The fitness room must also have approval from the Installation Commanding Officer.

Figure 14380-1. Mission Operation Command and Control Facility Building Blocks Diagram

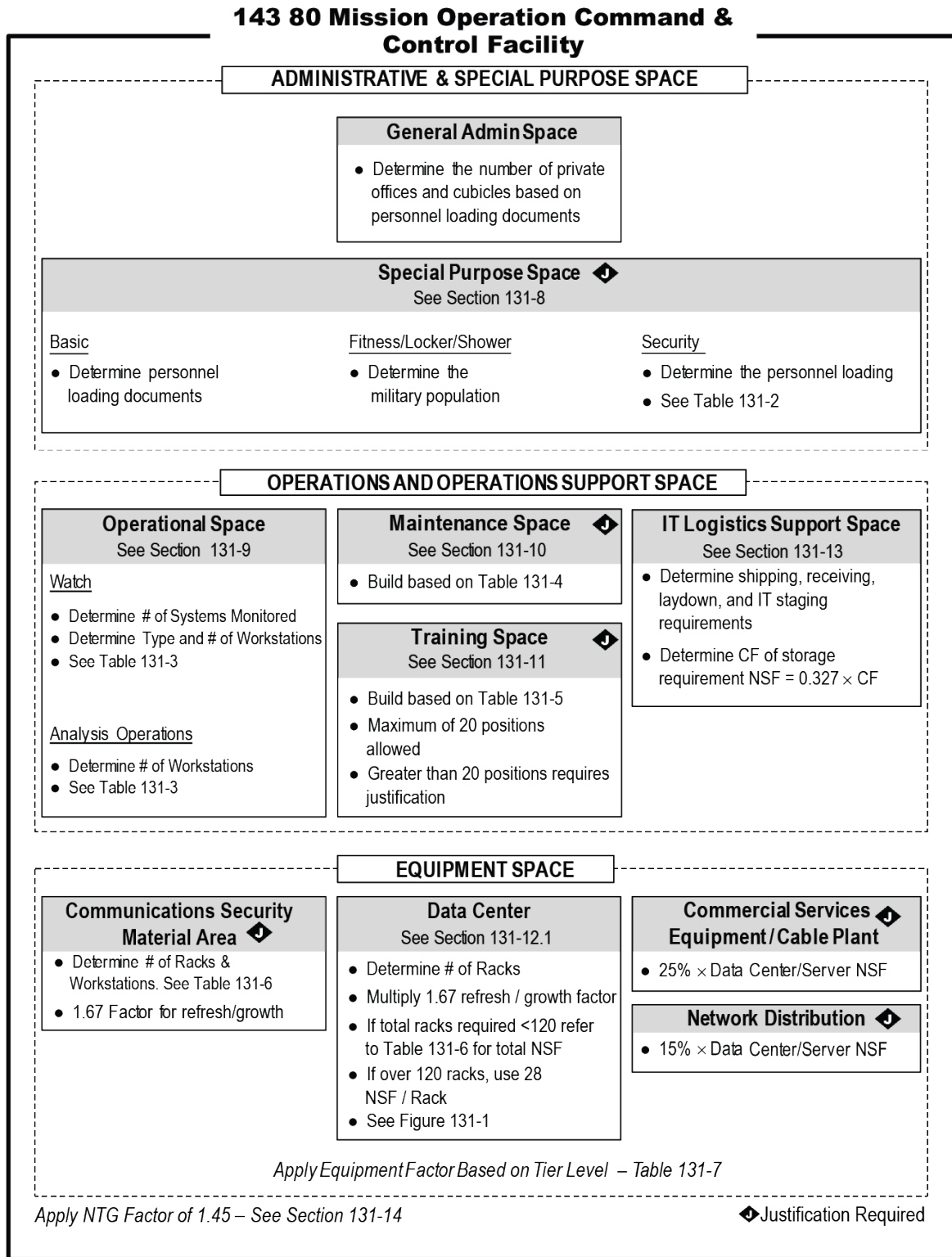

Apply NTG Factor of 1.45 – See Section 131-14 Justification Required

143 85 JOINT RESERVE INTELLIGENCE CENTER (JRIC) (SF)**FAC: 1444****BFR Required: Y**

14385-1 **DEFINITION.** Joint Reserve Intelligence Center (JRIC). A JRIC is a joint intelligence production and training activity that uses information networks to link reservist intelligence personnel, active duty units and contractors with the combatant commands, Services, and/or combat support agencies. A JRIC is located within a Service-owned and managed sensitive compartmented information (SCI) facility and may also include surrounding collateral and unclassified areas involved in the performance and direct management of intelligence production work that uses Joint Reserve Intelligence Program infrastructure and connectivity. The JRICs located around the country are equipped to effectively serve as satellite elements to combatant command Joint Intelligence Operations Centers (JIOCs), however they are shared facilities that serve multiple customers and missions.

14385-2 A JRIC contains the total requirements for office space, intelligence production space, support space, equipment and communications spaces, maintenance and training spaces, and limited storage space. The technical and operational mission of a JRIC will require that it contain, Secure Compartmented Information Facility (SCIF) areas, an Uninterruptible Power System (UPS), emergency generator system(s), and in selected cases, Radio Frequency Interference (RFI) shielding, Electromagnetic Interference (EMI) shielding, and Telecommunications Electronics Material Protected from Emanating Spurious Transmissions (TEMPEST) protection. It may contain dedicated communications architecture and operational systems that require it to have its own connectivity via direct satellite systems. The JRIC uses DIA/DoDIIS/DS-OGT for infrastructure and connectivity in “state of the art” Data Centers located within the SCIF.

14385-3 A JRIC may contain the functional areas outlined below.

14385-3.1 **Office Area.** Areas are provided for, but not limited to, the Site Manager (Officer in Charge), Administrative Staff, JRIC Operations Officer and JRIC Site Systems Administrator. Additional office space may be required to support the (Reserve Intelligence Area) Commander, Deputy, Chief of Staff, Command Support Staff (N-00), Special Staff (N-01/02), DCOS Manpower and Personnel (N-1), DCOS Intelligence and immediate Support Staff (N-2), DCOS Operations and immediate Support Staff (N-3), DCOS Logistics/Supply/Material and immediate Support Staff (N-4), DCOS Plans and Policy and immediate Support Staff (N-5), DCOS & Combat Systems and immediate Support Staff (N-6), DCOS Tactics and immediate Support Staff (N-7), DCOS Requirements, Readiness, and Assessment and immediate Support Staff (N-8).

14385-3.2 **Support Area.** The following support areas are normally required.

- **Reception Area.** A reception area, normally shared by the Commander, Deputy Commander, and Chief of Staff is required. This area should be capable of accommodating a minimum of eight (8) personnel. This is essentially a screening area for un-cleared personnel. This includes receptionist and visitors.

- **Commanders Conference Room.** A Conference Room normally shared by the Commander, Deputy Commander, and Chief of Staff capable of supporting a minimum of eight (8) personnel may be required.
- **Conference/Classroom Room.** Requirement is predicated on Base Loading/Stationing plan of supported units/activities.
 - **Command VTC/Conference Room.** A large area performing the function of an Auditorium/Conference Room may be required. The size of this area is dependent on the stationing/base loading plan, staffing and size of the JRIC.
 - **Break/Lounge/Galley Area.** As a result of the operational hours maintained within this facility, a small break/lounge/galley (kitchenette) area is required.
 - **Quarterdeck Area.** This multifunctional area provides an assembly or holding area for visitors awaiting escort, badge and pass issue and verification, and is considered the central point for ingress/egress. The quarterdeck will normally contain a maximum of two workstations requiring approximately 200 NSF.
- **Technical Publications Area.** This area may be required to store reference publications and literary data. It is configured similarly to a reference library in that it contains bookshelves, a reference area, and a working space for a minimum of two people requiring approximately 190 NSF.

14385-3.3 **Operational Area.** Not every JRIC will contain all of the areas listed, and there may be slight differences in terminology of the areas referenced below as a result of geographic specialization required at each respective location. In addition, although intended as a guide, the specific size of the areas provided below may vary as a result of the stationing/base loading plan and mission of the respective JRIC. An Engineering Evaluation will be used to determine the quantity and type of space required. Guidance provided within the Category Code series applied will be used * (see notes below).

- **Intelligence Operations Center.** This operational area is typically configured as a two to three room suite. The first area supports Operational Intelligence Production/Evaluation. This area will be configured based on mission essential tasks/functional requirements, be comprised of a certain number of A, B and C type workstations and include a conference area/collaborative multi-disciplinary work space with a table capable of seating eight (8). The second area supports Strike/Targeting production. This area will be configured based on mission essential tasks/functional requirements, be comprised of a certain number of A, B and C type workstations and include a conference area/ collaborative multi-disciplinary work space with a

table capable of seating eight (8). The third area supports Special Warfare intelligence production. This area will be configured based on mission essential tasks/functional requirements, be comprised of a certain number of A, B and C type workstations and include a conference area/ collaborative multi-disciplinary work space with a table capable of seating eight (8). Within the center there may be areas designated as Special Access Programs (SAP) areas (see below), which may contain a conference area with a table capable of seating eight (8), one type A workstation, video displays and wall maps, and support equipment (scanners, printers, copiers, et cetera).

A workstation = Connectivity to three (3) systems
(JWICS/SIPRNet/DNI-U)

B workstation = Connectivity to two (2) systems
(JWICS/ SIPRNet/DNI-U)

C workstation = Connectivity to one (1) system
(JWICS/ SIPRNet/DNI-U)

• **Imagery Exploitation/Production Area.** The Imagery Production Area may contain up to three (3) separate areas as follows:

a. **Imagery Analysis Area.** This area may be divided into separate rooms each of which supports up to twenty (20) personnel and contains imagery technician workstations, plotters and printers. The governing reference for design of these spaces is the National Geospatial-Intelligence Agency (NGA) Exploitation Facility Design Guidelines, version 2.1 dated 21 December 2006.

b. **Production Area.** This area contains one type A workstation, large format plotter, layout tables, light tables and imagery processor equipment.

c. **Administrative, Reference and Storage Area.** This area contains one type A workstation, bookshelves & map flats for imagery materials & supplies and administrative support equipment.

d. **Collaborative multi-disciplinary work space.** This area will include a conference area with a table capable of seating eight (8) and may be co-located with the imagery production area.

The minimum imagery exploitation space allocation for any JRIC will be a four (4) workstation room.

14385-3.4 **Operational Support Area**

JRIC Support Suite. The JRIC Support Suite may contain up to four (4) areas as outlined below.

- **Data Center.** This area typically contains one Type C workstation and a single row of six to ten racks of servers. An Uninterruptible Power Source (UPS) system and emergency generator system supporting this equipment is required for continuous operations capability. This area is also supported with a remote environmental monitoring system and a gas fire suppression system.
- **JRIC Operations Officer Area.** This area typically contains one unique conference table configuration capable of seating up to eight (8) personnel, a Type A workstation, and large wall mounted video display and maps.
- **JRIC Site System Administrator (JSSA) Area.** This area typically contains one Type A workstation and administrative support equipment (scanners, printers, copiers et cetera).
- **Secure Storage.** This area will contain secure storage containers as approved by the supporting Special security office (SSO).

DIA/DoDIIS-DS/OGT Support Area. An area is required for DIA/DODIIS-DS/OGT servers associated with the JWICS, SIPRNet and DNI-U. This area functions as the technical control and monitoring point for DIA/DODIIS-DS/OGT connectivity. This area may be co-located with the Data Center.

Minimum connectivity requirements: Each JRIC will receive connectivity based on unit/activity/agency mission requirements. The minimum JRIC standard is:

<u>System</u>	<u>Circuit Size</u>	<u>Quantity</u>
JWICS	OC-3 line	1
SIPRNet	DS-3 line	1
DNI-U	DS-3 line	1

In addition each line will have a “back-up” or redundant circuit which will be sized in order to meet minimum mission requirements.

Special Security Officer (SSO) Suite. The SSO Suite associated with a JRIC Facility is a multifunctional area containing, but not limited to, a Reception Area, Indoctrination Area, Photography Area, and Vault requiring approximately 280 NSF. Office space for the SSO and associated support staff are located within the SSO Suite, but special requirements for them should also be contained within the Office Area above. The SSO Suite is considered a secure area and must meet Sensitive Compartmented Information Facility (SCIF) criteria.

Secure VTC/Briefing Area. This area will normally be configured for a minimum of fourteen (14) personnel. It will contain video monitors, cameras, conference room seating, a computer workstation, Smart/white boards, briefing boards for large charts and video displays. A rear screen projection room may also be required in this area.

Mission Critical Communications Equipment Area. The Mission Critical Communications Equipment Area is unmanned. It may contain IEMATS consoles and processors, SATCOM terminals, UHF voice consoles and equipment, an EMATS fiber optic interface, WWMCCS, JWICS, and other applicable information data base terminals. An Uninterruptible Power Source (UPS) system supporting this equipment is required to sustain continuous operations. Secure telecommunications is a standard requirement (e.g., Standard Telephone Units (STU) analog systems and/or Standard Telephone Equipment (STE) digital systems), to be located as mission dictates.

Mission (Operations) Cells. In addition to the Operations and Operational Support Areas addressed above, selected JRIC's may require specialized Mission Cells. These cells may include, but are not limited to unique mission requirements or mission requirements incompatible with the supported units, activities or agencies (e.g., Force Cryptology Area, Fleet Support/Collection Management Area, Crisis Management Cell Area, et cetera). Each respective cell is arranged in a specific configuration, which will include a mix of rack mounted, and PC based systems. An Engineering Evaluation is to be used to determine the total number of cells required, quantity of racks and workstations associated with each respective cell.

Agency Support Area. The Agency Support Area is sized based on staffing. Agency personnel may be addressed under Office Area, and will only be contained within the Equipment and Operational Area if required by unique security issues.

Special Access Programs (SAP), Compartmented Area (CA). In accordance with Intelligence Community Policy Memorandum, Number 2006-700-7, dated 12 JUL 2006, Subject: Intelligence Community Modifications to DCID 6/9 Physical Security Standards for Sensitive Compartmented Information Facilities (SCIF's). A CA is a room, or set of rooms, located within a SCIF designed to enforce need-to-know. A CA is required when different compartment programs are sharing the same SCIF and not all SCIF personnel are cross-briefed. CA areas are mission specific and require an Engineering Evaluation.

14385-3.5 **Maintenance and Training Area.** Although not every JRIC Facility will contain all the areas listed, they are provided below as a guide. In instances where the respective allowances for the systems do not reflect configurations at the

site, an Engineering Evaluation will be used to determine the quantity and type of spaces required and guidance provided within the Category Code series will be applied.

System/Task Training Areas. Individual JRIC's may require dedicated 'modified academic' training areas. Training covers instruction and hands-on applications with operational equipment to provide Activity/Agency personnel, as well as Fleet personnel, with operator skills on existing and recently deployed systems. As CNO/CNI/DIA directives and operational requirements determine these classes, no formal yearly class schedule is established. Historical data shall be obtained on class sizes and the planning factor outlined in Category Code series 171 of UFC/NAVFAC P-80 of 45 nsf/pn applied.

Command Training Area. This academic training area is required to satisfy general training requirements for all of the RIA and JRIC units/activity/agency personnel. Training requirements cover general topics, which include but are not limited to, Quality of Life, Career Enhancement, Administrative, Educational Services, and Command Initiative Programs.

System/Task Maintenance Areas. Individual units and/or agencies may require dedicated systems/tasks maintenance areas. These maintenance areas may be configured with equipment racks and PC based workstations. An Engineering Evaluation and/or historical data shall be used to determine the quantity and configuration required for mission support, and guidance provided within the Category Code series section applied.

Flexible Secure Working Area (FlexSWA). To accommodate a broad range of system/ task training and command training requirements, where there is limited space availability for the JRIC, or greater space flexibility is required, it is possible to design and develop a Flexible Secure Working Area that is built to SCIF standards (DCID 6/9 requirements), but is configured to accommodate multiple functions and all levels of work, from unclassified up to TS/SCI, as required.

14385-3.6 **Storage Area.** A dedicated storage area may be provided for each unit/activity within the JRIC Facility. Allowance is based on Tables of Allowances/Modified Table of Organization and Equipment or equivalent.

Common Support Space Requirements. Note: Restrooms are required in both the SCIF and unclassified spaces. The restrooms in the unclassified spaces should have showers to support the full-time staff.

General. A JRIC is a remote joint service intelligence production and training activity that uses information networks to link reservists, active-duty units and contractors with

the Combatant Commands, Services, and/or Combat Support Agencies (C/S/A). A JRIC is located within a DoD-owned and managed Sensitive Compartmented Information Facility (SCIF) and surrounding collateral/unclassified areas involved in the performance and direct management of intelligence production work that uses JRIP (Joint Reserve Intelligence Program) infrastructure and connectivity. JRIC's provide interoperable intelligence support systems on which reserve elements simultaneously fulfill their intelligence support missions/production requirements and train on their Mission Essential Tasks. Reference: DoD Directive 3305.7, "Joint Reserve Intelligence Program (JRIP). For specific design information, please contact NAVFAC Atlantic Asset Management division.

144 40 SCALE HOUSE (SF)

FAC: 1444

BFR Required: N

14440-1 **DEFINITION.** A building that provides a protective enclosure for the operator of a vehicle/railcar weighing station. Sizing will be on a case-by-case basis and no criteria is available.

148 SHIP AND OTHER OPERATIONAL FACILITIES - OTHER THAN BUILDINGS

148-1 **GENERAL.** This category group contains facilities and structures which support tactical or organizational ship and other land operations in which do not fall readily into another category. For facilities supporting aircraft operations, use category group 149.

148 10 SHIP PROPULSION SUPPORT FACILITY (EA)

FAC: 1481

BFR Required: Y

14810-1 **DEFINITION.** Planning and programming for this facility requires concurrence and planning guidance by NAVSEA Code 08.

148 15 SHIP WEAPONS HANDLING FACILITY (EA)

FAC: 1491

BFR Required: Y

14815-1 **DEFINITION.** No planning factors are available. Each facility requires individual justification and space requirements; please contact Director, Strategic Systems Program (SSP) Office.

148 17 SPACE SURVEILLANCE ANTENNA (EA)**FAC: 1456****BFR Required: N**

14817-1 **DEFINITION.** Requirements are determined by Naval Network and Space Operations Command. Facilities typically support global space surveillance network which detects, tracks, identifies, and catalogs man-made objects in space and provides position information on these objects.

148 20 ORDNANCE DEMOLITION AREA (EA)**FAC: 1783****BFR Required: Y**

14820-1 **DEFINITION.** An ordnance demolition (treatment) area is a location specifically designated and reserved for destroying explosives and explosives-loaded devices. The function typically means burning or detonating explosives in a bermed open burn/open detonation (OB/OD) area. Coordinate justification for this area with the EOD units or other users. Planning and scoping this facility should consider governing environmental federal and state regulations, user requirements and explosive safety criteria. This area must meet the requirements of NAVSEA OP-5 Vol.1 and OPNAVINST 3770.2 (series) for FAA clearance requirements. All ordnance demolition (treatment) areas located in the United States and U.S. territories are required to have a Resource Conservation and Recovery Act (RCRA) permit. The shelter/bunker for the demolition area will be captured under CCN 173-40 Observation Tower/Bunker. Use Category Code 178 30 for a demolition training range.

148 25 EXPLOSIVE TRUCK HOLDING YARD (SY)**FAC: 8526****BFR Required: Y**

14825-1 **DEFINITION.** This yard is where trucks containing ammunition and/or explosives are held for interim periods of time prior to storage or shipment. Safe havens and wharf yards near piers and wharves should be categorized under this function. Each facility requires individual justification. Depending on land constraints and explosive safety criteria these facilities may or may not be barricaded. For containerized ordnance, use Category Code 148 35, Container Holding Yard.

148 30 EXPLOSIVES RAILROAD CAR HOLDING YARD (EA)**FAC: 1493****BFR Required: Y**

14830-1 **DEFINITION.** This is a temporary holding area for railcars containing ordnance prior to storage or shipment. Each facility requires individual justification. Depending on land constraints and explosive safety criteria these facilities may or may

not be barricaded. For containerized ordnance use Category Code 148 35, Container Holding Yard.

148 35 CONTAINER HOLDING YARD (SY)

FAC: 8526

BFR Required: Y

14835-1 **DEFINITION.** This is an open area that provides a temporary holding or staging area for containers loaded with explosive ordnance. Wharf yards near piers and wharves are also described by this function. Containers with explosive ordnance class/ Division 1.1 and 1.2 may or may not be in a bermed/barricaded area. Loaded containers can be stacked two high or singly on chassis or flatbed trailers. No planning criteria are provided because of the multiple container handling equipment possibilities and container configurations. A simple layout sketch of the proposed container holding

area, allowing for safe maneuvering of the container handling equipment, will generate the required space requirements.

14835-2 Minimum holding capacity of all holding yards should approximate one shipload of containers or the equivalent of 24 hours of sustained out-loading for the particular terminal operation.

148 40 CONTAINER TRANSFER FACILITY (ORDNANCE) (SY)

FAC: 8526

BFR Required: Y

14840-1 **DEFINITION.** A container transfer facility is used to transfer containers between rail flatcars and truck flatbeds or chassis, on a paved hardstand area, by means of a bridge crane or container handling equipment. Scale equipment should be expected to a part of this function. The area may be barricaded or unbarricaded. The size of the facility should be capable of handling a sustained maximum out-loading for the number of container throughput served in a 24-hour period. Determine the standard transfer rates given the type of container handling equipment. The mix of arrivals and departures of containers on rail or truck requiring transfer determines the how much material handling equipment is necessary to sustain the maximum out-loading. The area of paved hardstand and parking is dictated by the rate of container arrivals and departures. The control and service building of 204 SF provides office space, toilet facilities, etc. for employees. See Figure 14840-1 for a notional transfer facility using a bridge crane.

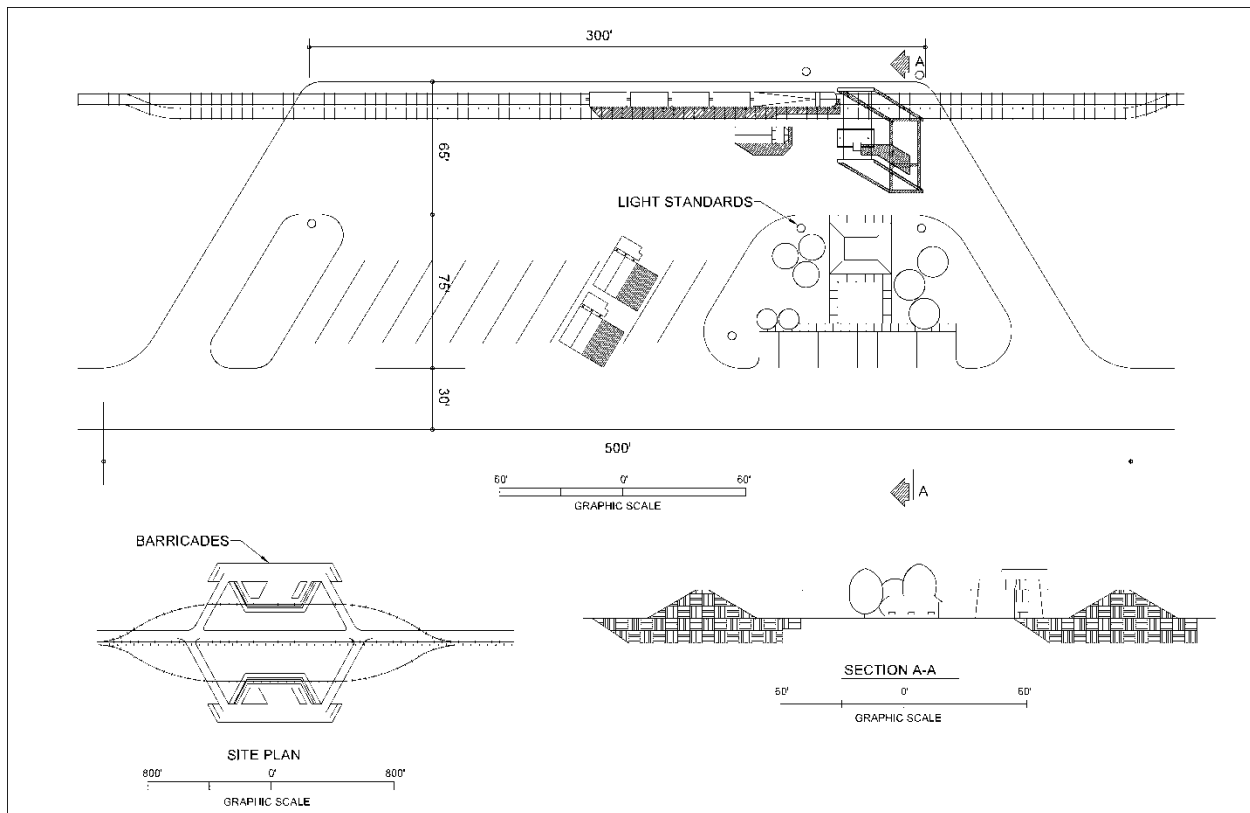

Figure 14840-1 Container Transfer Facility (Ordnance)

148 45 RAIL/TRUCK RECEIVING STATION (ORDNANCE) (SY)

FAC: 8526

BFR Required: Y

14845-1 DEFINITION. A rail/truck receiving station weighs and inspects all incoming shipments of break-bulk and containerized ordnance arriving by rail or truck and also a percentage of the outgoing shipments. Also, this station can be used as a short term storage facility limited to overnight and weekend periods and as an interchange storage facility limited to overnight and weekend periods and as an interchange yard between common carrier and station. The capacity of the receiving, inspecting, and weighing facility is based on expected maximum truck and rail arrivals and departures during a sustained out-loading. Figure 14845-1 provides a notional layout for a high-volume ordnance receiving and inspection station. This notional facility can process 20 rail cars per hour and 20 trucks per hour and provide for a 40-truck parking area and 100 rail car siding. It contains two rail inspection pits and two truck inspection pits, scales, lighting, and 2,432 SF of administrative space.

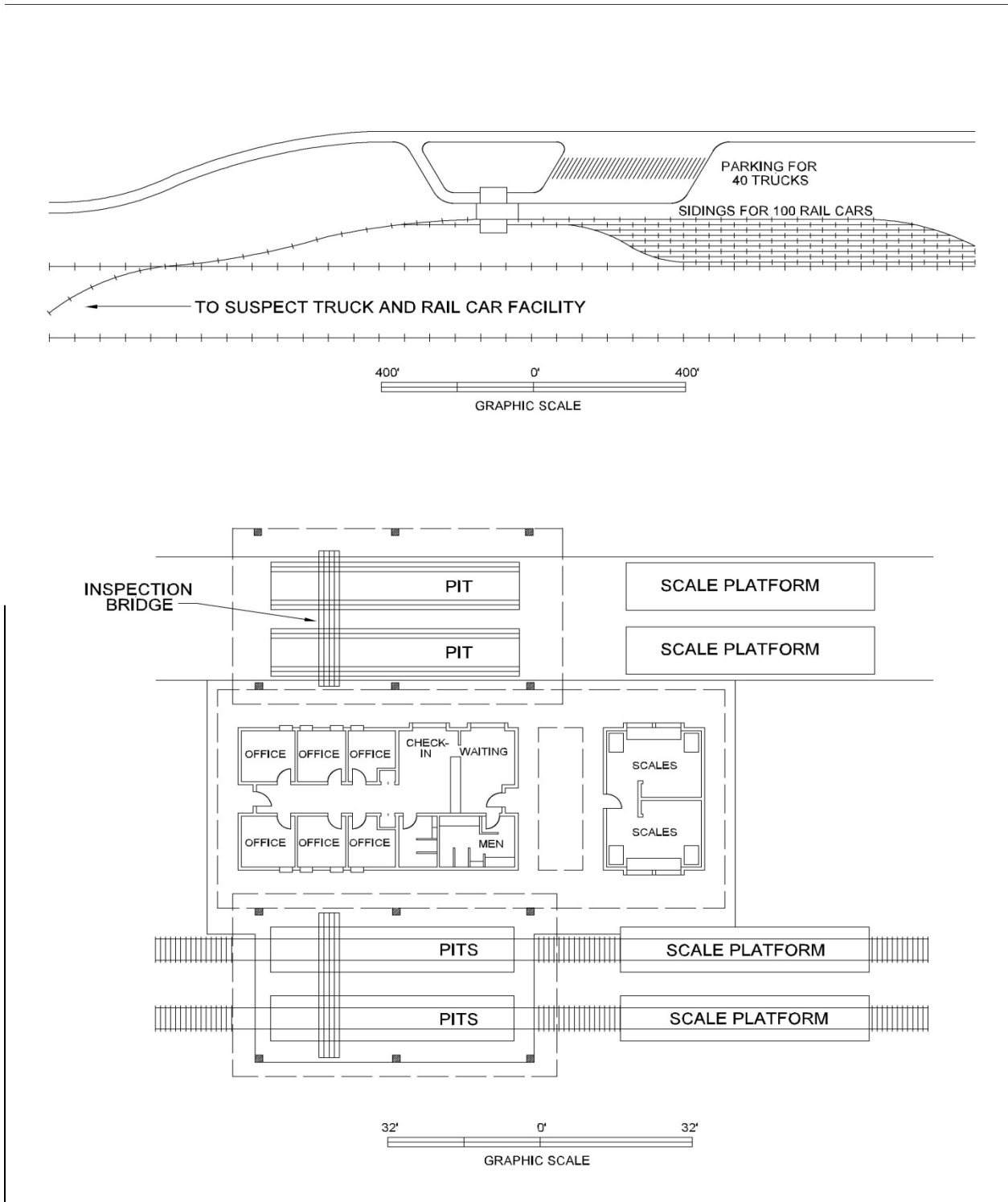

Figure 14845-1 Rail / Truck Receiving Station (Ordnance)

149 OPERATIONAL FACILITIES- OTHER THAN BUILDINGS

149-1 **GENERAL.** This category group contains facilities such as towers and structures which support tactical or organizational aircraft related operations and which do not fall readily into another category. It includes protective construction.

149 10 AIRCRAFT REVETMENT (EA)

FAC: 1495

BFR Required: N

Design Criteria: None Available

14910-1 **DEFINITION.** Protective Barricades (also known as revetments) are constructed at locations where explosive safety dictates the need, such as in magazine areas, combat aircraft loading areas, etc. They can be either steel structures or man-made earthen berms.

Aircraft revetments are constructed only for emergencies or in combat zones for the protection of aircraft against fire, blast, or enemy action. Aircraft revetments will be sized according to the aircraft that it is to protect. Specific criteria for this requirement will be determined by field conditions and will be planned only on specific instructions of the Fleet or Area Commander. For planning purposes, the unit of measure is each (ea); that is, the number of protected aircraft sites.

Explosive barricades for suspect truck or rail cars are captured under CCN 860 20, Explosive Barricade for Suspect Trucks and Railroad Cars.

14910-1 **DEFINITION.** Aircraft revetments are constructed only for emergencies or in combat zones for the protection of aircraft against fire, blast, or enemy action. Aircraft revetments will be sized according to the aircraft that it is to protect. Specific criteria for this requirement will be determined by field conditions and will be planned only on specific instructions of the Fleet or Area Commander. For planning purposes, the unit of measure is each (ea.); that is, the number of protected aircraft sites.

149 15 FIXED POINT UTILITIES SYSTEM (EA)

FAC: 1467

BFR Required: Y

Design Criteria: UFC 4-121-10N, Aircraft Fixed Point Utility Systems

Planning Criteria: P-80.3, Aviation Operation and Support Facilities; UFC 3-260-01, Airfield and Heliport Planning and Design

14915-1 **DEFINITION.** Fixed Point Utilities Systems (FPUS) supply utilities to aircraft parking apron service points and aircraft maintenance hangar service point. The

FPUS can provide compressed air, preconditioned air for hangared aircraft, and/or electrical power. The system can consist of an enclosed pump house and storage tanks, an in-ground distribution system and service points in aircraft parking aprons or aircraft maintenance hangars. There are typically four types of systems:

1. Air Start System. Provides compressed air at the parking apron. Aircraft cooling is provided by mobile ground carts. Electrical power is provided by separate, dedicated service panels.
2. Environmental Control System. Provides compressed air for engine starting and environmentally controlled compressed air for aircraft cooling from a central source. Electrical power is provided by separate, dedicated service panels.
3. Flight Line Electrical Distribution System (FLEDS). Provides electrical power to aircraft parked on the aircraft parking apron.
4. Point of Use Frequency Converter System (Super Flight Line Electrical Distribution System (SFLEDS)). Provides conditioned (filtered and compensated) electrical power to aircraft parked on the aircraft parking apron.

Layout of FPUS shall be subject to the correlated siting of maintenance hangars, parking apron and taxiways. Aircraft parking and FPUS layout is prescribed under Aircraft Parking Apron, Category Code 113 20 and UFC 3-260-01, Airfield and Heliport Planning and Design.

149 20 AIRCRAFT CATAPULT (EA) (DELETED)

This CCN has been deleted because it is non-RP (the catapult system is equipment). However, the support building(s), which can be above or below ground, are now captured under CCN 319 10 MISCELLANEOUS EQUIPMENT AND ITEMS LABORATORY.

149 30 AIRCRAFT ARRESTING GEAR (EA)

FAC: 1461

BFR Required: N

Design Criteria: AFI 32-1043, Managing, Operating, and Maintaining Aircraft Arresting Systems, FAA AC 150/5220-22B, Engineered Materials Arresting Systems (EMAS) for Aircraft Overruns

Planning Criteria: UFC 3-260-01, Airfield and Heliport Planning and Design

14930-1 **DEFINITION.** Aircraft arresting gear is designed to bring an aircraft to a stop in case of an aborted takeoff or an emergency landing.

Aircraft arresting systems consist of engaging devices and energy absorbers. Engaging devices are net barriers, disc supported pendants (hook cables), and cable support systems that allow the pendant to be raised to the battery position or retracted below the runway surface. Energy absorbing devices are ships anchor chains, rotary friction brakes, such as BAK-9 and BAK-12, or rotary hydraulic systems such as the BAK-13

and E-28. The systems designated “Barrier, Arresting Kit” (BAK) are numbered in the sequence of procurement of the system design. There is no connection between the Air Force designations of these systems and their function. Other designations such as E-5, E-28 and M-21 are U.S. Navy designations. The U.S. Air Force systems in use today are MA-1A; E-5; BAK-9; BAK-12; BAK-13; BAK-14; 61QSII (BAK-15); E-28; and Textile Brake. Other types of systems include the Mobile Aircraft Arresting System (MAAS) and Soft-Ground Type Aircraft Arresting System/Engineered Material Arresting System (EMAS).

14930-1.1 **E-5.** This unidirectional emergency arresting system is a U.S. Navy design and designation. Much like the MA-1A, this system uses several shots of ships’ anchor chain as the energy absorber, but these systems are never connected with a barrier (net). These systems can have from 1 to 4 disc-supported hook cables, with designations of E-5 and E-5 Mod 1 through E-5 Mod 3.

14930-1.2 **E-28.** The E-28 aircraft arresting system is a rotary hydraulic arresting gear that will accommodate a maximum aircraft weight of 35,400 kg (78,000 lbs) and a maximum aircraft engaging speed of 293 km/hr (160 knots). Aircraft engaging the E-28 arresting gear are stopped within a runout distance of approximately 305 meters (1,000 feet). Engagement can be made from either runway direction and at points up to 12.1 meters (40 feet) on either side of the runway centerline. The high performance (Model E-28) type of arresting gear is planned for both primary and secondary (crosswind) runways. Normally, two sets of arresting gear are required for each operative runway; one at each end between 274 meters (900 feet) and 457 meters (1,500 feet) inboard from the runway threshold. Midpoint arresting gear may be included on the station BFR when justified by runway or operational conditions and when approved through appropriate channels.

14930-1.3 **M-21.** The M-21 aircraft arresting system is a lightweight high-capacity arresting system for the recovery of aircraft. The arresting engines utilize the vortex principle of energy absorbing in a hydrodynamic braking system.

14930-1.4 **MA-1A.** The MA-1A emergency arresting system consists of a net barrier and cable system designed to engage the main landing gear of an aircraft. Because it is a unidirectional system, it must always be installed in the overrun area. Most MA-1A systems employ ships’ anchor chains as the energy absorber. These systems require a runout area of at least 259 meters (850 feet) plus the length of the aircraft. The chains lie on either side of the runway overrun, beginning at the barrier location and running in the direction of aircraft travel; however, some MA-1A systems use a BAK-9 instead of a ships’ anchor chain as the energy absorber. These systems require a runout area of at least 290 meters (950 feet) plus the length of the aircraft. *The MA-1A is not currently in production as a system.*

14930-1.5 **BAK-9.** The BAK-9 is an obsolete bi-directional emergency arresting system. It consisted of 1 energy absorber that employed 2 rotary friction brakes and purchase-tape reels mounted on a common shaft. The reels were mechanically connected at the midpoint by a third brake that acted as a clutch. This allowed each reel to turn at different speeds during off-center engagements and

helped steer the aircraft toward the center of the runway. The energy absorber for these systems was installed below grade on 1 side of the runway and the purchase tape was routed to the opposite side of the runway through deflector sheaves and duct. The other purchase tape was routed to a turnaround sheave located in a pit sited to allow both purchase tapes to be of equal length. *The BAK-9 is not currently in production as a system and should not be considered as a suitable system for a new requirement.*

14930-1.6 **BAK-12.** The BAK-12 is the standard U.S. Air Force operational aircraft arresting system. This bi-directional system employs 2 energy absorbers. Each absorber consists of 2 multi-disc rotary friction brakes mounted on either side of the purchase-tape reel on a common shaft. The energy absorbers are located on opposite sides of the runway, connected to a 32 millimeter (1.25 inch) disc-supported pendant by the purchase tape. Ideally, the energy absorbers should be in a below-grade pit with a minimum split distance of 15.24 meters (50 feet). (Split distance is a measurement taken between the lead-on sheave of the fairlead beam or deck sheave, and the energy absorber.) Split distances of up to 91 meters (300 feet) are acceptable for all BAK-12 installations. You may also install BAK-12 systems above ground in one of two configurations, the selection depending upon site conditions and operational requirements. These are the expeditionary installation for periods of up to 1 year, and the semi-permanent installation, well-suited for long term use and typically selected when site conditions will allow a pit-type installation.

Originally, BAK-12 energy absorbers were fitted with a 60-inch purchase-tape storage reel. This design allowed the maximum energy expected to be imparted during an aircraft engagement to dissipate within a runout of 290 meters (950 feet) plus the length of the aircraft. Designers have since improved the BAK-12 to meet increased demands of heavier and faster aircraft. They retrofitted the energy absorbers with larger 66-inch or 72-inch tape storage reels to accommodate increased runout, thus increasing the total energy capacity of the system. Although some BAK-12 systems have 60-inch tape storage reels, new and upgraded BAK-12 systems have 66-inch reels. These systems require 366 meters (1,200 feet) plus the length of the aircraft for maximum runout. The 72-inch reel systems are special-purpose systems configured for 610 meters (2,000 feet) of runout.

The standard BAK-12 is configured for cross-runway separations of up to 61 meters (200 feet) (distance between fairlead beams or deck sheaves). For installations with cross-runway spans exceeding 61 meters (200 feet), replace the BAK-12 control valve cam to accommodate full runout of the system.

Dual BAK-12 systems are special-purpose installations configured to accommodate high-energy engagements of aircraft ranging from 27,200 to 63,500 kilograms (60,000 to 140,000 pounds). These configurations consist of 4 BAK-12 energy absorbers arranged in pairs on either side of the runway. The energy absorbers may be standard BAK-12s or be equipped with 72-inch diameter tape storage reels to accommodate 610 meters (2,000 feet) of runout. You need special tape connectors and edge sheaves for these installations.

14930-1.7 **BAK-13.** The BAK-13 is a bi-directional aircraft arresting system. It employs 2 velocity-sensitive energy absorbers installed on opposite sides of the runway, interconnected by nylon purchase tapes and a 32 millimeter (1.25 inch) disc-supported pendant. The energy absorbers are made from a steel weldment base that incorporates a tape-storage reel mounted on a vertical shaft and a vaned rotor assembly enclosed within a vaned stator assembly (also called a tub) that contains a water and glycol mixture. A rewind engine, transmission assembly, and an operator control panel are also included along with necessary hydraulic system components.

The energy imparted during an aircraft arrestment converts heat through the turbulence developed by rotation of the vaned rotor within the vaned stator. An external cooling reservoir permits rapid cycle of this system.

The site requirements are essentially the same as for the BAK-12; however, the low-profile units maybe located as close as 46 meters (150 feet) from the runway edge if installed in a semi-permanent configuration. These systems require 290 meters (950 feet) plus the length of the aircraft for maximum runout. *The BAK-13 is not currently in production as a system. I should not be considered as a suitable system for a new requirement due to the potentially high hook load generated during engagement.*

14930-1.8 **BAK-14 and Type H Hook cable Support Systems.** The BAK-14 hook cable system is a bi-directional hook cable (pendant) support system used in conjunction with the BAK-12, BAK-13, or a comparable arresting system to engage and safely stop a hook-equipped aircraft. It provides the means to support the pendant at least 2 inches above the runway surface while giving ATC the means to lower the pendant below the surface of the runway to prevent damage to low-undercarriage aircraft, the pendant, and the pavement below the pendant during trampling. These systems can accommodate 46, 60, and 90 meters (150, 200, and 300 foot)-wide runways, but you order the system to suit the specific application. The control side BAK-12 pit or protective shelter and foundation must be expanded to house the compressed air and control systems needed to operate this supplemental system.

The Type H hook cable support system is a bi-directional hook cable support system that can be used in conjunction with any type of energy-absorbing device. It provides a means to raise a cable at least 2 inches above a runway surface or lower it below the runway surface in less than 1.5 seconds. It can be supplied to accommodate runway widths of 46, 60, and 90 meters (150, 200, and 300 feet). A radio remote control system provides ATC the means to operate the system and to monitor its operational status. It mainly consists of Retraction Modules (from 14 to 18 depending on runway width) installed into pre-cast concrete blocks across the runway, and connected together by metallic rods, to form a rigid loop. This loop is actuated by an electro-hydraulic motor that is located in a concrete pit on one side of the runway.

14930-1.9 **BAK-15.** The BAK-15 aircraft arresting barrier consists of a pair of electro-hydraulically powered steel masts that provide support and remote-

controlled movement for a unidirectional nylon net barrier. The masts are installed on opposite sides of the runway overrun on concrete foundations. The ATC tower contains a remote control panel, which can be hard-wired but the most common is radio controlled.

The barrier must be augmented with an energy-absorbing device such as a ship's anchor chain, BAK-12, or Textile Brake. During an aircraft engagement, shear links in the net suspension straps separate by the force of the aircraft engaging the net. The net then envelops the aircraft and seats on the leading edge of the wings, transferring forward momentum of the aircraft to the energy-absorbing device.

You can complement the system with a standard disc-supported pendant to accommodate tail hook engagements through interconnect configuration hardware similar to that used for the MA-1A Modified. The hook cable interconnect kit is designated as the 62 NI (net interconnect).

14930-1.10 **Textile Brake.** This modular arresting system is primarily intended as an emergency backup system for standard operational systems. It is comprised of multiple modules arranged in equal numbers on both sides of the overrun that contain specially woven textile tearing straps to absorb the kinetic energy generated during an engagement. One end of each module is anchored to the ground and the other end is connected to a tensioned cable positioned across the runway. The system is available in a 2-stage unidirectional configuration (MB 60.9.9.C) or as a single stage bi-directional system (MB 100.10.C).

The advantages of the 2-stage system (MB 60.9.9.C) over the bi-directional system (MB 100.10.C) are higher system capacity and lower costs for reconfiguration after low energy engagements. The modules in a stage (breaking lines) are expended upon aircraft engagement and must be replaced; however, a life cycle analysis indicates system costs are approximately 50 percent of the life cycle cost for a BAK-12 installed in the overrun area of a runway due to the low number of engagements that occur there. These systems are designed for tail-hook equipped fighter aircraft, but can also be complemented with a net barrier such as the BAK-15 or a net/cable interconnect system. They may also be configured for expeditionary or temporary installations.

If the bi-directional version of the Textile Brake arresting system is installed on the operational runway surface due to a non-standard length overrun, the Arresting Gear Marker (AGM) signs should be blanked when viewed from the approach. This is because the system is a low energy capacity system (compared with BAK-12 or BAK-13), and is not intended for approach end engagements.

14930-1.11 **Mobile Aircraft Arresting System (MAAS).** The MAAS is essentially a BAK-12 aircraft arresting system mobilized through installation on a specially developed trailer. It is configured for a maximum aircraft runout of 302 meters (990 feet). This system was initially developed and tested to accommodate recovery of fighter aircraft returning to a battle-damaged airfield. Such cases require rapid deployment and installation, and may require that only the minimum essential

anchoring hardware be installed to accommodate the above scenario. When installed for this purpose, the MAAS is installed using a 19-stake anchoring scheme. This configuration is limited to unidirectional engagement capability with a maximum aircraft weight and speed of 18,144 kilograms (40,000 pounds) at 150 knots.

The MAAS can be upgraded to accommodate bi-directional engagements with the full capacity of a standard BAK-12 aircraft arresting system. This is accomplished by increasing the total number of cruciform stakes used to anchor the system from 19 to 31, extending the runout to 366 meters (1,200 feet), and synchronizing the system for higher brake pressure. The system may also be installed in a set-back configuration to accommodate wide body aircraft operations through use of a fairlead beam.

14930-1.12 **Soft-Ground Type Aircraft Arresting System.** The Engineered Material Arresting System (EMAS) is an FAA-approved soft-ground system normally used for civil airports to mitigate short safety areas (less than 305 meters (1,000 feet) long) at runway ends. The system is constructed of cellular foam concrete of specific strengths and thickness to decelerate an aircraft that overruns the runway through rolling resistance. The design for each system is aircraft specific, based upon the type of aircraft that will use the runway. It is intended for use where it is impractical to obtain the standard 305 meter (1,000 foot) safety area and other alternatives are not feasible. For purposes of design, the soft ground arrestor system can be considered fixed by function and frangible since it is designed to fail at a specific load; therefore, a soft ground system is not considered an obstruction to navigation. Soft ground systems are located beyond the end of the runway, centered on the extended runway centerline. They will usually begin at some distance from the end of the runway to avoid damage due to jet blast or short landings. This distance will vary depending on the available area and the specific system design.

149 45 MISSILE LAUNCH FACILITY (EA)

FAC: 3901

BFR Required: N

14945-1 **DEFINITION.** This Category Code is provided for inventory purposes of missile and drone launch pads. See NAVSEA OP-5 for Explosive Safety Siting criteria of energetic liquids associated with launch pads.

149 50 BLAST DEFLECTOR FENCE (EA)

FAC: 1464

BFR Required: N

Design Criteria: None Available

14950-1 **DEFINITION.** Blast deflector fences are structures that direct the exhaust from jet engines upward. They are used in congested areas and parking and maintenance areas to protect personnel, equipment, structures, aircraft, and other

vehicles from the blast effect of jet engine exhaust. Blast fences are also used to prevent erosion of paved and unpaved areas and to provide protection from flying debris. Their siting and length must be based on the study of individual station requirements. Blast deflector fences may be purchased or constructed in sections to permit moving them from one position to another as protection requirements change. Careful selection of location is necessary to prevent creating an obstacle to taxiing aircraft.

149 62 TACTICAL VEHICLE WASH FACILITY (SF)

FAC: 1496

BFR Required: Y

14962-1 **DEFINITION.** A wash structure located to support maneuver/training areas and provide prewash mud removal and washing of military vehicles. Structure typically provides water-soaking capability for tactical tracked and wheeled vehicles, high and low pressure cleaning capability, water cannons, wash water containment and drains, sediment basins, and sludge removal. Prep and prewash areas, wash stations, water treatment, water supply, basins and controls/equipment are included as components of the facility. The facility that houses the controls/equipment is captured under CCN 89009 Miscellaneous Utility Building.

14962-2 **REQUIREMENTS.** Sizing requires an engineering analysis on a case-by-case basis. No criteria is available for this category code.

149 85 EXPEDITIONARY AIR CONTROL SITE – MACS AND MASS (EA)

FAC: 1467

BFR Required: Y

Design Criteria: UFC 4-141-10N, Aviation Operation and Support Facilities

14985-1 **DEFINITION.** These are Marine Corps facilities required to accommodate, in-garrison, the equipment used for expeditionary aircraft command and control. These facilities are assigned to specialized Marine Corps squadrons, and the expeditionary equipment used in conjunction with these facilities is normally squadron property. The Marine Air Control Squadron (MACS) and the Marine Air Support Squadron (MASS) are squadrons within the Marine Air Control Group (MACG) and Marine Aircraft Wing (MAW) that are directly responsible for air defense and air control. Each MACS contains two Air Traffic Control (ATC) Detachments and one Air Defense Detachment. The ATC Detachments were formerly the Marine Air Traffic Control Unit (MATCU). Both the MACS and MASS are squadrons in the MAW and are directly responsible for air defense and air control.

149 86 OPERATIONS SUPPORT SHED (EA)**FAC: 1499****BFR Required: Y**

14986-1 No criteria currently exist for this category code.

151 PIER FACILITIES

151-1 DEFINITION. A pier is a structure that extends out from shore into navigable water and is designed for the homeport or temporary berthing of vessels. Services available at pier side include, but are not limited to, ship repair, fueling, training and other essential services, such as potable water, electric power, compressed air, waste disposal and communications facilities. A pier is oriented either perpendicular to or at an angle with the shore and normally accommodates berthing on both sides for its entire length although there are instances where only one side is used because of site conditions or because there is no need for additional berthing space. Code 151 includes all piers regardless of function served, protective dolphins at pier heads, fendering systems, and mooring fixtures, original dredging performed specifically for the purpose of providing the pier facility, all trackage on the pier, and all supporting utilities and services.

Piers provide a transfer point for cargoes and/or passengers between water carriers and land transport. Separate facilities should be maintained where service involves large volumes of both cargo and passengers. Joint service use of piers should be considered when at all possible.

In countries outside the United States, a pier is often referred to as a jetty, or a mole when of solid fill construction, and a wharf is referred to as a quay or a jetty. In the United States, the term jetty refers to a solid fill structure, located on an open seacoast at the mouth of a river or tidal inlet, designed to prevent shoaling of a channel by littoral materials and to direct and confine stream or tidal flow.

For data on channel and turning basin dredging, see UFC 4-150-06, Military Harborts and Coastal Facilities. For utilities and services landward of the inboard end of the pier, see UFC 4-150-02, Dockside Utilities for Ship Service. For crane and railroad trackage on shore, see Civil Engineering and Utilities, MIL-HDBK-1005/6. For transit sheds on piers, see category code 156 10; and for fixed crane structures, see category code 213 40.

Piers are classified according to their primary function and are described under their respective category codes.

151-2 BERTHING. Piers are used to provide either multipurpose berths or special purpose berths. Piers providing multipurpose berthing are used to service several classes of vessels so that ships will have the option of utilizing any one of several berthing facilities at a port. Berth selection depends upon the need to match available

space, utilities and support services with the requirements of an incoming ship. It is not economically feasible to develop a single facility to accommodate and service all classes of vessels. Special berths are provided when berthing arrangements and/or locations are required for fueling vessels, berthing vessels carrying explosives, and for repairing vessels.

151-3 FEATURES. The following list gives appurtenances and facilities generally provided at or near piers. The facilities to be provided depend on functional requirements, which often determine the classification of the pier. The location of support facilities will be dependent upon the existence of weapons handling Explosive Safety Quantity Distance (ESQD) Arcs.

Located on the pier:

1. Berths having sufficient depths and widths to allow for efficient servicing of ship and safe vessel approach and departure.
2. Sufficient mooring devices (bollards, bitts, cleats) to safely secure vessel.
3. Hotel and ship service facilities.
4. Fender systems, oil containment booms and floating/fixed AT/FP barriers
5. Camels or struts.
6. Brows and stands for ship access to the pier
7. Access facilities for railroad cars, trucks and emergency vehicles.
8. Cranes and trackage.
9. Privately Owned Vehicle (POV) parking

Provided by the host activity in the general area of the pier:

1. Cargo handling equipment.
2. Firefighting equipment.
3. Covered and open storage space for cargoes; fenced where required, for control of pilferage.
4. Office space.
5. Sanitary facilities.
6. Ship support and repair facilities.

7. Medical facilities.

151-4 LOCATION AND ALIGNMENT. The location and alignment of piers in a harbor should consider factors such as ease of entering and leaving berth, required quayage, harbor line restrictions, adjacent navigational channels, foundation conditions and isolation requirements. For further information and criteria, see Military Harbors and Coastal Facilities, UFC 4-150-06.

151-5 PIER DIMENSIONS AND CLEARANCES. The dimensions of a pier are based primarily on the lengths of the vessels, present or contemplated, that it is to accommodate. The length of the pier is dependent upon the type of ship, and the width is dependent upon the type of service to be provided. Pier measurements and allowances for single-length and multiple-length berths are based upon either accommodating known vessels or known types of vessels, where types but not specific ships are known. The dimensions for both types are determined as follows:

1. Pier Length.

- a. Single-Length Berth shall equal the overall length of the largest vessel to be accommodated, plus an allowance of 50 feet at each end of the vessel. For aircraft carriers, the allowance at each end of the vessel is 100 feet. See Figure 151-10 for berthing diagram. Reference the following ship characteristics data in UFC 4-152-01 Piers and Wharves as follows:

Table 2-1 Ship Characteristics for Selected Ships (Fully Loaded)

Table 2-2 Ship Characteristics for Selected Ships (Lightly Loaded)

- b. Multiple-Length Berths shall equal the total overall length of the largest vessels simultaneously accommodated, plus allowances of 100 feet between vessels, 50 feet between the shore and the inshore ship and 50 feet beyond outermost moored vessels. See Figure 151-10 for berthing diagram.

2. **Pier and Wharf Width.** The width of a pier or wharf is determined on the basis of functional requirements, space availability and site conditions such as water depths, subsurface conditions and clearances. The widths of piers and wharves, as discussed hereinafter, refer to the dimensions determined for specific function classifications. These dimensions should not be less than the widths determined by geotechnical and structural considerations. Factors to be considered in the determination of pier and wharf widths are as follows:

- Berths Provided on Outboard Face of Pier. Because pier widths are determined on the basis of the requirements of the main berths, the outboard face, or the end of a pier may be used only for vessels whose overall length does not exceed the width of pier and where bow and stern clearances conform to established criteria. The proximity to

shipping lanes and high-energy wave environments may prohibit the use of this portion of the pier.

- Berths Provided Alongside Pier or Wharf. Total structure width depends upon the size of the transit shed, if any, type of crane service provided, number of railroad tracks, firefighting equipment and truck lanes furnished and requirements for work space and open storage areas. At wharf facilities, open storage areas are often contiguous to the apron and shed, but at pier facilities open storage areas are generally located off the pier and thus do not affect the determination of total pier width. Table 15111-1, indicating minimum pier widths, is furnished as a guide.
- Berths for Carriers. Carriers specifically designed to breast off aircraft carriers should be provided at designated carrier berths. Alternatively, the provision of additional pier width may be considered to provide clearances for overhangs of flight decks and elevators.
- Services Requiring Additional Width. Adequate width should be provided to accommodate railroad tracks, truck lanes, crane ways, emergency response equipment and fuel handling equipment when furnished.

3. Slip width.

- General Considerations. The clear distance between piers, or slip width, should be adequate to permit the safe docking and undocking of the maximum size vessels that are to be accommodated in the slip. The size of slip should also permit the safe maneuvering and working of tugboats, barges, lighters and floating cranes. At multiple berth piers, where vessels are docked either one per berth, two abreast per berth, sufficient clearance should be available to permit the docking and undocking of vessels at the inshore berth without interfering with vessels at the offshore berth. Because the size of a slip is affected by docking and undocking maneuvers, consideration should be given to the advice of local pilots who are familiar with the ships to be handled and with prevailing environmental conditions such as winds, waves, swells and currents. The slip width should be reviewed with specific functional requirements of the individual installation before a final determination is made.
- Minimum Width of Slip for Active Berthing. Minimum widths should be as shown on Figure 151-10. Widths are defined as a factor times the beam of the largest vessel to be accommodated. The minimum width should not be less than 300 feet. The recommended criteria are applicable only if vessels are turned outside the slip area.

Reference the following ship characteristics data in UFC 4-152-01 Piers and Wharves for the beam of typical vessel types as follows:

Table 2-1 Ship Characteristics for Selected Ships (Fully Loaded)

Table 2-2 Ship Characteristics for Selected Ships (Lightly Loaded)

At submarine slips, width requirements should be increased by at least four vessels beam and more, as required, to account for camels and separators, to provide for ships' vulnerability if their safety is involved, to provide for special maneuvering requirements of other ships during berthing or passing and to provide for special environmental conditions such as currents, waves and winds.

- The requirements discussed above apply where vessels are berthed on both sides of a slip. Where vessels are berthed on only one side of a slip, the width may be reduced.
- Referring to Figure 151-10, when more than 2 abreast berthing is employed, the width of slip should be increased by one ship beam for each additional ship added in order to maintain adequate clearances between moored ships during berthing and un-berthing maneuvers. Thus, for 2 abreast berthing on both sides of a slip, the slip width for single berth piers would be equal to 8 times ship beam and the slip width for multiple berth piers would be equal to 9 times ship beam.
- Minimum Width of Slip for Active Berthing. At slips containing inactive berths where vessels are stored for long periods of time on inactive status, in nests of two, three or more, clear distances between moored vessels and slip width may be reduced by one or two vessels beam to reflect the reduction in the frequency of berthing maneuvers and the decrease in activities of small boats and floating equipment.

4. Water Depth in Slips.

Minimum Depth of Water. In a sheltered harbor and where the harbor bottom consists of soft material, water depth in a slip, measured from Mean Lower Low Water (MLLW) should be equal to the maximum loaded draft of the vessels to be accommodated plus a minimum clearance of 4 feet which includes an allowance of 1 foot for vessel trim in loading, 2 feet for under keel clearance and an allowance of 1 foot for tidal variations. For the loaded draft of typical vessel types, refer to UFC 4-152-01 Piers and Wharves as follows:

Table 2-1 Ship Characteristics for Selected Ships (Fully Loaded)

Table 2-2 Ship Characteristics for Selected Ships (Lightly Loaded)

Additional information is available in UFC 4-150-06 Military Harbors and Coastal Facilities at <https://www.wbdg.org/ffc/dod/unified-facilities-criteria-ufc/ufc-4-150-06>. Specified water depths should be maintained as close to the fender line of the structure as is practicable considering the accessibility of dredging equipment used during maintenance dredging operations.

a. Other Considerations. Minimum keel clearance of 4 feet should be increased if any of the following conditions prevail:

- Harbor bottom consists of a hard material such as rock.
- Excessive silting (one foot per year or more) occurs.
- Slip area is exposed to waves, swells and winds.
- Extreme low water (one foot or more) occurs.
- Investigation indicates probable fouling of condensers.

Aircraft carriers have had situations where they suck up bottom sediments and marine organisms through their intakes, clog up condenser coils and cause undue wear on machinery. In model tests it has been determined that one part of the solution to these situations is to increase the depth below the keel. Therefore, the water depth at carrier berths and anchorages shall be 50 ft. from MLLW datum for new construction. Water depth at existing facilities shall be increased to 50 ft. where feasible. Depths for AOE's may be increased for similar reasons. However, special studies at specific locations are required.

For Vessel Characteristics, refer to UFC 4-152-01 Piers and Wharves as follows:

Table 2-1 Ship Characteristics for Selected Ships (Fully Loaded)
 Table 2-2 Ship Characteristics for Selected Ships (Lightly Loaded)

These tables provide a comprehensive listing of pertinent data for vessels in the naval fleet. The following is a list of footnotes which applies to the tables:

- Ordinarily, extreme breadth is the maximum width of vessel. For submarines, the value given is the maximum diameter or width of the hull structure and is not necessarily the maximum width which may occur at the horizontal stabilizer planes and is so noted. Canted aircraft carrier flight decks may not be dimensionally symmetrical about the longitudinal centerline of the vessel, marking the extreme breadth value for aircraft carriers unsuitable for determining berthing camel width at piers and wharves with gantry crane service.
- Maximum navigational draft is the minimum depth of water required to prevent grounding of a vessel due to appendages projecting below the vessel's base line or keel. Such appendages may be sonar domes, propellers, rudders, hydrofoils, vertical submarine control planes, etc. Many vessels also possess a decided trim to the bow or stern in fully loaded condition or in the case of submarines, a trim to the stern in surfaced condition.

- Water depth at carrier berths and anchorages is 50 ft. from MLLW datum for new construction. Water depth at existing facilities will be increased to 50 ft. where feasible. Depths for AOE's may also be increased if justified.

**Table 15111-1
Typical Pier and Wharf Widths**

Function Classification	Vessel Type	Minimum Pier Width (feet)	Minimum Wharf Apron Width (feet)	Railroad Tracks (standard gage)	Rail-Mounted Cranes
1. Ammunition	Ammunition	100	100	-	-
2. Berthing	Aircraft Carrier	100	-	-	-
3. Berthing	Cruiser	80	-	-	-
	Destroyer	80	-	-	-
	Frigate	80	-	-	-
	Submarine	60	-	-	-
	Auxiliary	80	-	-	-
4. Fitting-out	Destroyer	100	-	2 tracks; 1 each side	2-30 ft. Gage; 1 each side
5. Repair	Cruiser	125	-	4 tracks; 2 each side	2-30 ft. Gage; 1 each side
	Auxiliary	125	-	4 tracks; 2 each side	2-30 ft. Gage; 1 each side
6. Fueling	Auxiliary	50	-	-	-
7. Supply (General Cargo)	Auxiliary	125 plus shed width	60	2 tracks	-
8. Supply (Container Cargo)	Auxiliary	80	80	Up to 3 tracks	1 50 ft. Gage

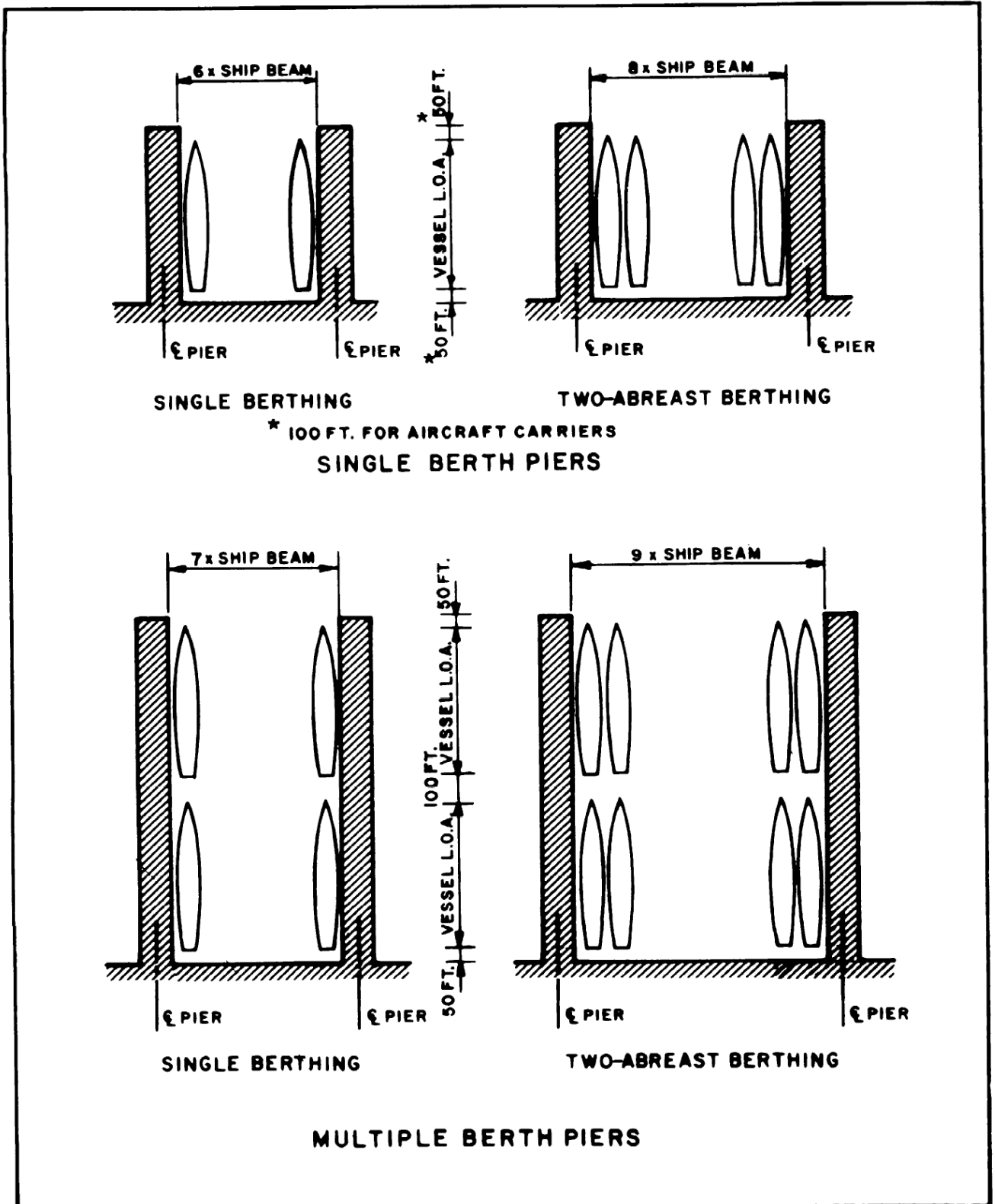

FIGURE 151-10
Slip Widths

151 10 AMMUNITION PIER (FB)**FAC: 1511****BFR Required: Y**

15110-1 DEFINITION. Ammunition piers are designed for use in the receipt of ammunition for storage and for the offloading of ammunition onto barges and ships. In some cases outgoing ammunition is first loaded from the ammunition pier onto barges for transfer to ships moored offshore or in a roadstead. The services and facilities provided for ammunition piers include lighting, telephone and fire alarm systems, and salt water for firefighting. Railroad tracks are normally provided unless the established method of handling ammunition is by truck. Freshwater is provided if a supply is readily available. For dimensional and other pertinent information, see Code 151. For quantity-distant standards for pier and wharf facilities handling explosives and ammunition, see NAVSEA OP-5, Volume 1. This pier is for break bulk load/off-load of ammunition. For containerized load/off-load of ammunition, use Category Code 151 70, Ordnance Container Handling Pier.

151 20 GENERAL PURPOSE BERTHING PIER (FB)**FAC: 1511****BFR Required: Y**

Design criteria: see Piers and Wharves, UFC 4-150-01

15120-1 DEFINITION. General Purpose Berthing Piers are used primarily for mooring home ported and transient ships that do not require piers equipped with shipyard facilities. Berthing piers are classified as active or inactive. The active berthing piers are used when ships are berthed for a relatively short time; the inactive classes are used when ships are to be tied up for long periods in a decommissioned status.

When berthing for carriers is to be provided on one side only or on both sides of a berthing pier the width of the structure shall be adequate to provide clearance for the overhang of the flight decks and sponsors. Alternatively, camels or other separators may be provided to fend off carriers.

All piers regardless of their function, will include such appurtenances as protective dolphins, fender systems, and dredging in connection with the facility. Supporting utilities, crane/railroad trackage, fixed cranes, and transit sheds on piers will carry their appropriate category codes. For other pertinent information, see Code 151 (general notes).

151 40 FUELING PIER (FB)**FAC: 1511****BFR Required: Y****Design criteria: see Piers and Wharves, UFC 4-150-01**

15140-1 DEFINITION. Facilities for berthing ships while discharging fuel to storage or receiving fuel from storage are provided at fueling piers. Such piers will provide salt water for firefighting, telephone and fire alarm facilities and may provide freshwater, steam in cold climates, electric power. In addition, a fuel main and special protective hose racks and small derricks for handling fuel hoses are necessary. They shall also be equipped with pipelines for each type of fuel to be stored at the site, including bilge and ballast lines. Stripper pumps for emptying lines are also necessary. A fueling pier may be justified for those stations where bulk quantities of liquid fuel can be economically handled by water transportation. These piers vary according to the service required, the local exposure to wind and water, and the geologic formation of the site.

For dimensional and other pertinent information, see Code 151.

151 50 REPAIR PIER (FB)**FAC: 1511****BFR Required: Y****Design criteria: see Piers and Wharves, UFC 4-150-01**

15150-1 DEFINITION. Repair piers are constructed and equipped to permit overhaul of those portions of a vessel above the waterline. These structures will normally be equipped with a gantry crane and standard-gage railroad tracks and have facilities to provide salt and freshwater, steam, compressed air, telephone and fire alarm service, and electric power for ship service, lighting and welding. In some cases industrial gases may be provided.

For dimensional and other pertinent information see Code 151.

151 60 SUPPLY PIER (FB)**FAC: 1511****BFR Required: Y****Design criteria: see Piers and Wharves, UFC 4-150-01; Supply Facilities, UFC 4-442-01N and MIL-HDBK 1032/2.**

15160-1 DEFINITION. Supply piers accommodate berthing for the transfer of materials between ship and shore. A large building or transit shed normally occupies the central portion of a supply pier. The pier width will be in direct ratio to the width of the shed or sheds, placed longitudinally down the center of the pier. For example, the shed for a ship needing 600 feet of berthing space is 150 feet wide. Transit sheds are normally placed side by side parallel with the long axis of the pier when both sides of a

pier are used for shipments. The pier width should then be from 380 to 420 feet because the pier deck or apron should be from 40 to 60 feet wide to accommodate railroad track, dock truck trains and allow proper cargo handling. Space restrictions at some seacoast installations will undoubtedly dictate the construction of piers of lesser width. In such cases, transit sheds must be designed with these restrictions. Planning for supply piers at installations will usually be restricted to industrial seaport locations having a primary stock point mission. For dimensional and other pertinent information relative to supply piers other than that in the preceding paragraph, see Code 151.

151 70 ORDNANCE CONTAINER HANDLING PIER (FB)**FAC: 1511****BFR Required: Y**

15170-1 DEFINITION. An ordnance container handling pier is used primarily for the offloading and receiving of explosive ordnance in containers from non-self-sustaining container ships. This does not preclude use of the pier by conventional break-bulk or self-sustaining container ships. The pier should be sited in accordance with NAVSEA OP-5, Volume I. The services and facilities provided on the pier are lighting, telephones, fire alarms, and salt water for firefighting. Railroad tracks are provided where the normal method of drilling containers to the pier is by Trailer on Flat Car or Container on Flat Car (TOFC/COFC). Rails are flush with pier deck surface for ease of operations when moving containers by trucks on the pier.

For dimensional and other pertinent data, see Category Code 151Series (general notes) and UFC 4-150-01 Piers and Wharves.

151 71 DEGAUSSING PIER (FB)**FAC: 1511****BFR Required: Y**

15171-1 DEFINITION. Sizing for this Category Code is based on the type of vessels to be serviced and is driven by the NAVSEA specified equipment. Special studies are required on a case by case basis.

151 80 DEPERMING PIER (FB)**FAC: 1511****BFR Required: Y**

15180-1 DEFINITION. Sizing for this Category Code is based on the type of vessels to be serviced and is driven by the NAVSEA specified equipment. Special studies are required on a case by case basis.

151 90 ACCESS TRESTLE TO PIERS AND WHARVES (SF)
FAC: 1513
BFR Required: Y

No criterion currently exists for this category code.

152 WHARVES

152-1 GENERAL. A wharf is an open type marginal structure for the berthing of vessels; it is usually connected to the shore at more than one point. In most cases it will accommodate berthing along the outer face only, although a portion of the inner face may provide berthing space at a shallower draft. A wharf does not necessarily have continuous access to the shore. In general, the planning criteria that apply to piers are also applicable to wharves. Either may serve the same practicable purpose, however, since their physical design and layout will be much different, their capacities for berthing and cargo handling will vary. Piers are generally preferable structures; however, certain locations will dictate the use of a wharf rather than a pier because of the marginal fairway and topography involved.

For general planning information pertinent to wharves listed under Category Code 152 10 through Code 152 80, see the same pier designation listed under Category Code 151 10 through 151 80. The corresponding category codes for wharves are as follows:

152 10 AMMUNITION WHARF (FB)
152 20 GENERAL PURPOSE/BERTHING WHARF (FB)
152 30 FITTING OUT WHARF (FB)
152 40 FUELING WHARF (FB)
152 50 REPAIR WHARF (FB)
152 60 SUPPLY WHARF (FB)
152 70 ORDNANCE CONTAINER HANDLING WHARF (FB)
152 71 DEGAUSSING WHARF (FB)
152 80 DEPERMING WHARF (FB)

153 CARGO HANDLING OR STAGING AREAS

153 10 CARGO STAGING AREA (SY)
FAC: 8526
BFR Required: Y

15310-1 DESCRIPTION. A cargo staging area is an open hardstand for temporary storage of cargo awaiting further transshipment. For Open Storage, approximately 30,000 square feet of open storage area is required for each 431 short tons, or 385 long tons, or 1,000 measurement tons of cargo on hand per month based on a conversion

factor of 2.32 measurement tons per short ton. For conversion factors for different commodities see page TBD. Average stacking height should be six feet. The square footage requirement should be established at 10% more than the space needed at peak times unless there is a wide discrepancy between the average amount of cargo on hand per month and the largest amount of cargo on hand at any one month during the last year. The square footage requirement should be established at 15% more than the average space needed in peak times if the discrepancy is recurring in nature. Average amount of receipts compared to issues per month as well as average hold time of cargo per month may be useful in developing data to support the facility requirement.

154 SEAWALLS, BULKHEADS, QUAYWALLS

154-1 **GENERAL.** Seawalls, bulkheads, and quay walls are shore protective structures not intended primarily for berthing vessels. Bulkheads and quay walls have the principal advantage of affording accessibility for their entire length along the foreshore. In addition, a much greater working area normally is available at each berth for storage, laydown, and repair operations than at berths alongside piers and wharves. The ratio of berthing space to a given length of waterfront, however, is much less for bulkheads and quay walls. The relative cost per berth is much greater for quay walls, especially for those in deep water or at sites with poor foundation conditions. Maneuverability into a berth at a long quay wall occupied by ships in adjoining berths is more difficult than entry into a single-length pier berth. In spite of these drawbacks, a quay wall may prove to be the only choice at a site located along a river or other relatively narrow channels if the natural terrain is high along the shore, making dredging of a recessed basin for piers very expensive, or if there is insufficient width of waterway for safe navigation into finger piers projecting out at an angle from the natural shoreline.

154 10 SHALLOW WATER BULKHEAD AND QUAYWALL WITHOUT A RELIEVING PLATFORM (LF)

FAC: 1541

BFR Required: N

15410-1 **DESCRIPTION.** This type of bulkhead or quay wall is a structure to retain earth along a shoreline in shallow water. The depth of water is typically limited to a 25 feet and the structure has no relieving platform. This structure does not provide ship berthing (151 Piers and 152 Wharves should be used for any ship berthing requirement). Typically these structures are found between piers or wharves and are often used for Small Craft Berthing. It should be noted that this is a functional definition independent of the design type. Using today's technology bulkheads and quay walls have many useful design alternatives and the most economical construction should dictate the design based on local conditions.

15410-2 The linear footage and type of bulkhead required at any one installation would be determined by site location, the availability of real estate, topography, currents and wave action.

154 20 DEEP WATER BULKHEAD AND QUAYWALL WITH A RELIEVING PLATFORM (LF)**FAC: 1512****BFR Required: Y**

15420-1 **DESCRIPTION.** This type of bulkhead or quay wall is a structure to retain earth along a shoreline in deep water. Typically with a water depth exceeding 25 feet and includes a relieving platform to support heavy logistics operations. This structure does not provide ship berthing (151 Piers and 152 Wharves should be used for any ship berthing requirement). Typically these structures are found between piers or wharves and are often used for Small Craft Berthing. Using today's technology bulkheads and quaywalls have many useful design alternatives and the most economical construction should dictate the design based on local conditions.

15420-2 The linear footage and type of bulkhead required at any one installation would be determined by site location, the availability of real estate, topography, currents and wave action.

154 30 SEAWALLS AND RIP RAP (LF)**FAC: 1541****BFR Required: N**

15430-1 **DESCRIPTION.** These are structures built along and parallel to a shoreline (river or coast line) protecting and stabilizing the shore against erosion resulting from wave and current action. This is a functional definition and various types of construction can be used to support this function. The most economical and efficient structure for a particular location can be determined only after a thorough study of local hydrographic and meteorological conditions, the amount and type of protection desired, and the characteristics of the property to be protected. This type of structure is often used in conjunction with a Category Code 871 35 Retaining Wall.

155 SMALL CRAFT BERTHING

This basic category group provides facilities supporting small craft operations. Included in this category are, but not limited to, yard craft, tug boats, security and service craft.

155 10 FLEET LANDING (FB)**FAC: 1551****BFR Required: Y**

15510-1 **DESCRIPTION.** A fleet landing is a fixed or floating pier designed for the loading and/or unloading of a ship's personnel onto or from a personnel boat or ferry.

This facility must be in quiet water, carefully sheltered against disturbances. Water depth must be adequate for the type of ferry or service craft used. Requirements are developed based on the site specific conditions including tide range, available real estate and the types of crafts that will be using the facility. Category Code 155 20 can be used for general guidelines.

155 11 FLEET LANDING BUILDING (SF)

FAC: 1552

BFR Required: Y

15511-1 **DESCRIPTION.** A fleet landing building is a structure used to accommodate ship's personnel being loaded or unloaded from a personnel boat or ferry. The size and type of structure is dependent upon the average number of personnel being transferred at any one time and the type of climate in which the structure is located. In the absence of specific criteria, the quantitative requirements for the facility should be determined on an individual basis based on the experience and knowledge of the activity involved and the appropriate Systems Commands. Category Codes 155 21 and 159 64 can be used for general guidelines.

155 20 SMALL CRAFT BERTHING (FB)

FAC: 1551

BFR Required: Y

15520-1 **DESCRIPTION.** Berthing plans at waterfront facilities will provide space for all small craft authorized by CNO/CMC. Access and maintenance mooring arrangements should include facilities for harbor and pilot launches, survey boats, work boats, special service craft, rescue boats, and other small craft. If necessary, breakwaters will be provided for shelter against wind and wave action. Small boat piers and boathouses may be planned if several craft of medium and large size are to be accommodated. For medium and larger craft, water depth must be a minimum of 6 feet and preferably 8 feet at mean lower low water (MLLW). The pier may be designed to handle vehicles and provide turning space at the ell end of the pier. Water and electricity are required, as well as boat-fueling dispensers appropriately located on the pier. The utility services (800 series) and fueling for small craft (Category Code 122 30) are provided as secondary code items.

15520-2 **REQUIREMENT.** The requirement for Small Craft Berthing can be calculated using the following algorithm:

The following information should be obtained from Port Ops: CNO and other Small Craft loading, small craft dimensions, and the end-to-end spacing per type of small craft. If the end-to-end spacing varies between small craft types, then use the average spacing.

With the aforementioned information, the feet of berthing (FB) or meters of berthing (MB) necessary can be calculated using:

[Number of each type of craft x length (or width depending on orientation of the crafts)] + [end-to-end spacing required x total number of crafts]

In addition to the FB/MB necessary there are secondary factors to consider:

- Draft - Medium and large craft = minimum of 6 ft (1.83 m), preferably 8 ft (2.44 m) at mean lower low water (MLLW)
- Breakwater required (yes/no)?
 - If yes, then determine the required length (see Category Code 16410)
- Boathouse required (yes/no)?
 - If yes, then see Category Code 155 21
- Vehicle access required (yes/no)?
 - If yes, add FB/MB depending on the vehicle type
- Vehicle turning space required (yes/no)?
 - If yes, add FB/MB depending on the vehicle type

155 21 SMALL CRAFT BOATHOUSE (SF)

FAC: 1552

BFR Required: Y

15521-1 **DESCRIPTION.** A boathouse is necessary where an alert crew is required, where a boat facility is remote from the supporting activity, or where boat repair facilities are essential. Boat crew quarters or a boathouse may be programmed for those locations that justify an alert crew for the aviation rescue boats, where the boat facility is remotely located from the supporting facility, and where boat repair facilities (either Code 213 56 or 213 58 as appropriate) are required. The boathouse is programmed on the following basis:

Alert crew quarters	85 square feet per person
Office and shop space	85 square feet per person
	170 square feet per person
	(Includes toilet and custodial space)

A boat shelter is often included as part of this facility and is sized by a study of the vessels required to meet the specific mission.

The following facilities should be provided for: repair shops and working platforms, crew bunkhouse, toilets, mechanical equipment room, a small office, boat machine and carpenter shops, marine railway hoist or crane, covered storage, paint shop, battery shop, fuel storage tanks with pumping apparatus, water, electricity, and sail loft, if necessary. At mean lower low water (MLLW), the depths in a boathouse shall not be less than 5 to 6 feet. The ceiling clearances shall conform to the requirements of the various craft accommodated, but they should not be less than 16 feet. Working platforms should be about 3 feet above mean higher high (MHHW) water. A boathouse roof should provide cover over walkways and berths for emergency craft.

155 22 SMALL CRAFT BOAT RAMP FACILITY (EA)**FAC: 1591****BFR Required: Y**

15522-1 **GENERAL.** Both the Navy and Marine Corps have in-shore boat teams that patrol inland waterways in support of various missions such as providing military escorts; securing inland waterways; carrying out “presence patrols”, and performing peacekeeping missions. These “brown water” functions require the use of fast boats that can be launched in shallow water and are capable of negotiating inland waterways. These capabilities require shore facilities such as boat ramps and piers or bulk heads that allow for launch and retrieval of these boats from towable trailers. This category code should be used for both home-ported and forward deployed operational or security forces requiring small boat launch ramps for the purposes of conducting in-shore training maneuvers or security patrols.

15522-2 **DEFINITION.** Small Craft Boat Ramp Facilities will provide a finished boat ramp that allows for launching operational boats from trailers and will be sloped to allow for proper approach, launch, and retrieval of the tow vehicle and boat/ trailer combination. This facility also includes an associated launch pier (per lane), parking (secure, if needed), and any bulkhead or shoreline erosion control measures (i.e., riprap or quarry rock) deemed necessary. Where mission requirements dictate, the launch pier should be based on criteria under Small Craft Berthing, CCN 15520 and captured in iNFADS as a sub category on the ramp Property Record Card (PRC).

The parking areas and approach apron are constructed of concrete or asphalt and are required for all Small Craft Boat Ramp facilities. These areas should be sized according to the criteria for Operational Vehicle Parking, CCN 14312 and shown as a separate utilization on the Boat Ramp property record card. All areas of the ramp, associated parking, and maneuvering areas must include adequate site lighting to allow for night time operations. In some cases, these areas might also be required to be secured via fencing and access gates. The boat ramp final design is based on many factors but for initial planning purposes, these guidelines and Figure 15522-1 dictate the parameters for a single lane small craft boat ramp facility. Note: this CCN provides requirements for a single lane ramp and uses a unit of measure of “EA”. Where ramps are required to be more than one lane, increase the quantity on the property record card based on the number of lanes needed. For example, a four lane boat ramp facility will have a quantity of “4” on the associated property record card.

15522-3 **PLANNING CRITERIA.** Small Craft Boat Ramp Facilities should be coordinated for use with the various training and operational schedules of different tenant commands at an installation. Tenant commands requiring boat ramp facilities should work together to determine how many lanes are necessary based on the optempo of their training cycles. The information included here should be used as a guide for planning operational boat ramps and their support spaces but further detailed information can be found in the UFC 4-152-07 Design: Small Craft Berthing Facilities.

15522-4 **BOAT RAMP/LAUNCH PIER REQUIREMENTS (refer to Figure 15522-1)**

General guidelines:

1. Ramps will be planned at 20' wide (clear width) and be constructed of reinforced concrete. The concrete surface will be grooved to provide both traction and proper drainage. Ramp slope will typically be set at 8 degrees (approximately 14%) wherever possible. Overall ramp length will be predicated on the local site grade elevation with respect to the Mean Lower Low Water (MLLW) mark.
2. The launch pier can be either fixed or floating but must maintain a clear minimum width of 6'. Pier length from the MLLW will be 50' minimum.

Section (A) Approach:

1. Ramp approach transition from the shoreline to the ramp must be gradual to accommodate long prime-mover and trailer combinations. If the adjacent site terrain is relatively flat and does not have a natural slope towards the ramp, the approach apron must be vertically curved approximately 20' from the parking/circulation area elevation to the boat ramp (see Fig. 15522-1). This area is accounted for in the parking allowances determined under the associated Operational Vehicle Parking/Laydown Area CCN 14312.
2. Any pedestrian ramps along the pier length will have a max slope (up or down) of 4 degrees (approximately 7%) to transition between various tide levels.

Section (B) Ramp Above MLLW:

1. Ramp length from the water line/ramp transition at MLLW is based on the shore elevation above the MLLW (see Figure 15522-1.) This distance must be determined in the field.
2. Pier length from the water line/ramp transition at MLLW is also based on the shore elevation above the MLLW. Note that the pier deck can be sloped up to 4 degrees (up or down) at any point along its length to shorten the required distance between the pier and shoreline. This determination will be made in the field.

Section (C) Ramp Below MLLW:

1. Ramp length below the MLLW is approximately 45'. At the designated 8 degree slope, this provides for a 6' deep pool at the foot of the ramp. The pool must be a minimum of 6' below the MLLW in all cases.
2. The pier length is not to exceed 75' in length from the water line/ramp transition at MLLW out into the water (see Figure 15522-1.)

Figure 15522-1

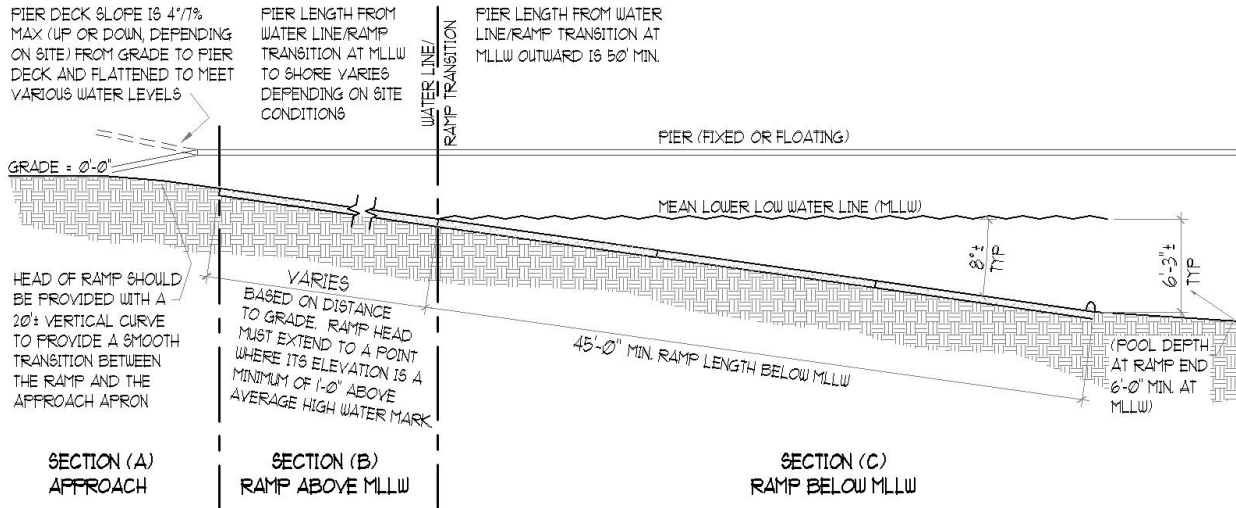

15522-5 ASSOCIATED WATERWAY AND SMALL CRAFT BERTHING. The basin (adjacent waterway) should be dredged to provide a minimum of 4' depth at MLLW. Bottom width at the ramp should be greater than the combined width of the launch ramp and boarding pier(s). Where required, small craft berthing should be planned and located in such a manner that it does not interfere with the actual launch procedures at the ramp or boat traffic within the basin. Any small craft berthing associated with this boat ramp facility should be captured under CCN 15520 Small Craft Berthing as a separate utilization on the boat ramp property record card.

15522-6 PARKING AND CIRCULATION. Small Craft Boat Ramp Facilities will require parking for prime mover and trailer combinations as well as any associated operational vehicles such as Humvees, pickup trucks, and passenger vans. Space allowances for parking, circulation, and apron areas at the boat ramp should be based on the criteria for CCN 14312 Operational Vehicle Parking/Laydown Area and captured in iNFADS under that category code. Note that this area under 14312 does not negate the need for parking allowances for the same vehicles at their permanent locations, usually operational facilities elsewhere at an installation.

156 CARGO HANDLING FACILITIES – BUILDINGS

156 10 WATERFRONT TRANSIT SHED (SF)

FAC: 1443

BFR Required: Y

15610-1 **DESCRIPTION.** A waterfront transit shed is a building or shed for storage of cargo awaiting further transshipment and requiring protection. For Covered Storage,

approximately 8,000 square feet of covered storage area is required for each 560 short tons, or 500 long tons, or 1000 measurement tons of cargo based on a conversion factor of 2.32 measurement tons per short ton. For conversion factors for determining storage requirements, see Section 440-2 General Supply Requirements in Category Code 440 Series. Average stacking height should be twelve feet.

The actual space assigned to an activity must be developed taking cognizance of many factors such as planned organization and mission changes, packaging and labeling requirements, commodity mix, local fire control procedures, MHE aisle space, etc. Therefore, the best approach to use for planning purposes is to develop a general square footage figure and then adjust that figure based on other quantitative/qualitative information available. It is recommended that the following criteria be used to develop a general square footage requirement:

- a. Average amount of cargo on hand per month.
- b. Average amount of receipts compared to issues per month.
- c. Largest amount of cargo on hand at any one month during the last year.
- d. Average hold time of cargo per month.

Basically, there are three situations that are taken into consideration for calculating the space requirements for the storage of cargo awaiting further transshipment and requiring protection. These situations are as follows:

Situation (1) A relatively uniform amount of cargo is stored each month throughout the year. Since there is relatively little discrepancy between the data obtained from a and c; the square footage requirements should be established at 10% more than the space needed at peak times.

Situation (2) A relatively uniform amount of cargo is stored each month throughout the year with the exception that there is a large discrepancy that results from a one-time situation as indicated from the data in c. The square footage requirement is established as 10% more than the average actual space used per month.

Situation (3) A relatively uniform amount of cargo is stored each month throughout the year with the exception that there is a discrepancy, which is recurring in nature and is predictable. The square footage requirement is established at 15% more than the average space needed during the peak times brought about by the discrepancies.

Data developed from b and d may be useful in explaining/factoring the developed requirements.

The same criteria should be used in determining space requirements for label cargo. It should be noted, however, that since quantities of label cargo on hand are usually small, modifications to existing facilities (firewalls, secure area, etc.) should be considered prior to initiating construction of new facilities.

156 20 CONTAINER OPERATIONS BUILDING (SY)**FAC: 1443****BFR Required: Y**

15620-1 **DESCRIPTION.** A container operations building is essential for safe direction and control of container operations to promote efficient and continuous flow to, within, and from the handling area. It is located to provide visual sighting of and two-way communication with handling operating facilities, such as shiploading, rail track and truck corridors serving and penetrating the handling area. The building contains muster areas, locker space, toilets, lunch room facilities, and an administrative area for container operations. A 50-foot tower contains two rooms at 30-foot and 40-foot levels for visual observation of ship, rail, and truck corridors and operational facilities.

A total gross area of approximately 6,000 square feet will house 15 employees in the administration area, 100 employees in the locker room, and 125 employees in the lunch room. The tower will accommodate 12 employees in approximately 700 gross square feet. The usual remoteness of this facility may necessitate the provision of parking spaces for all employees.

159 OTHER WATERFRONT OPERATIONAL FACILITIES

This basic category group provides for facilities which cannot be coded in basic groups 151 through 156.

159 10 AIRCRAFT DOCKING FACILITY (EA)**FAC: 1591****BFR Required: N**

15910-1 This category code is for inventory purposes only. It is intended for waterfront facilities that were originally created to support seaplanes such as PBV Catalinas and similar from the WWII era and later. It is not associated with any airfield criteria and new facilities will not be planned under this CCN.

159 20 DEGAUSSING BUILDING (SF)**FAC: 1431****BFR Required: Y**

15920-1 **DESCRIPTION.** Degaussing is the science dealing with the methods and techniques of reducing a ship's magnetic field so that the possibility of detection by magnetic mines and other magnetic influence detection devices is minimized. It consists of two functionally interdependent installations: An underwater Degaussing Range installation (Category Code 159 21) and this facility, which serves as an instrument station. The degaussing facility records a ship's magnetic field as it passes over the Degaussing Range and notifies the ship as to what adjustments must be made to the

degaussing coils on board the ship (with the exception of submarines which have none) in order to reduce the ship's magnetic field to a safe operational level. If the vessel's magnetic field cannot be sufficiently reduced because of excessive permanent magnetization, the ship is scheduled to report for deperming (the process of reduction of permanent magnetism). See Category Code 159 30 for criteria relating to a deperming facility.

The sizing of this facility is determined by a study for the specific location and is directed by the equipment specified by NAVSEA.

159 21 DEGAUSSING RANGE (EA)

FAC: 1591

BFR Required: N

15921-1 **DESCRIPTION.** A degaussing range is an area set aside in a channel or harbor that contains submerged instruments, connected to the computer in the degaussing building (Category Code 159 20), which registers a ship's magnetic signature as it passes through the range. The test equipment in the degaussing building indicates whether the internal degaussing system on board the ship is calibrated properly. If shipboard equipment is not within tolerance new calibration settings will be provided to the ship to neutralize the fields to within an acceptable tolerances. Shipboard equipment that is not operating properly will also be identified and if necessary the ship may be scheduled for deperming.

Range Location. The range site for the degaussing facility should be carefully selected because the type of range to be installed and the method of installation depend mainly on the depth of water. The water depth will vary in accordance with the size of vessel to be ranged. The shallow range is located in 15 to 30 feet mean water depth and is used to range minesweepers and other vessels of comparable size. The medium range, which is generally 45 to 60 feet below the surface, is used for surface combatants, auxillary and amphibious warfare ships. The deep range, used for heavy carriers and the like, is located in 75 to 100 feet of water. The variation in water depth should not be greater than 10 feet for a particular range (shallow, medium, and deep). The range location should be based on the following considerations:

- (1) Depth of water.
- (2) Types of sea bottom.
- (3) Tides and currents.
- (4) Position of range relative to range house.
- (5) Navigational hazards.
- (6) Heading of range (generally on a north-south magnetic heading).

The selection of a range site must be approved by local naval port authorities. Continental sites and installations must be approved by the U.S. Army Corps of Engineers. See Category Codes 159 20 Degaussing Building and 159 30 Deperming Building for additional information.

159 30 DEPERMING BUILDING (SF)**FAC: 1431****BFR Required: Y**

15930-1 **DESCRIPTION.** A Deperming Building is a facility that contains electrical instruments used to regulate and monitor the deperming operation. Deperming, the second phase of degaussing, is the process by which a ship's permanent longitudinal and athwartship magnetism is removed and its permanent vertical magnetism stabilized at a low level. The deperming facility consists of a Deperming Building, which serves as an instrumentation building, a Deperming Wharf, Category Code 151 80, and, if required, a generator house. The Deperming Building floor area is determined by the amount of equipment and the number of personnel determined by NAVSEA. Pier size must accommodate any size ship that requires deperming. Plans must include electrical facilities capable of meeting the power requirements determined by NAVSEA.

159 50 FERRY SLIP (EA)**FAC: 1591****BFR Required: N**

15950-1 **DESCRIPTION.** A ferry slip provides the anchorage for ferries while loading or unloading. It consists of water areas directly in front of transfer bridges and is usually bordered by fender racks. The offshore waters must provide maneuvering area for the largest ferry to be accommodated. Depth of water depends on the ferries accommodated. For design criteria, see Waterfront Operational Facilities, MIL-HDBK-1025/1.

159 64 WATERFRONT OPERATIONS BUILDING (SF)**FAC: 1431****BFR Required: Y**

15964-1 **DESCRIPTION.** A Waterfront Operations Building provides administrative space for the functions associated with the management of a naval port, and support for all ship berthing and small craft maintenance including related electronics systems. It may provide space for functions such as a duty crew bunk room, crew's lounge, boatswain's locker, berthing for small boats if an integral part of the building, space for storage of boat gear and paint, oil spill equipment and a battery charging room.

This facility, which is under the cognizance of the officer in charge of port operations, is also staffed by personnel such as the dispatcher, dock master and harbormaster. Several functions performed are coordinating logistic support and harbor services, coordinating all movement of ships within the port as well as those entering and leaving, assigning ship berthing spaces, and providing pilots, operating tugs, service craft and small boats. The space for the office proper is based on the number of administrative people assigned. (See Category Code 610 10 for space allowances). Duty crew space shall be 85 net sf per person as detailed in Category Code 155 21. Space for the maintenance and boatswain's functions are determined by an industrial analysis for the

specific functions at each location. The industrial analysis shall include factors including the size of the port serviced, the size of the ships utilizing the port-and the frequency of movement of ships within the port and entrance channel(s).

In conjunction with the office space, a control tower with an unobstructed view of the entrance channel and berthing area may be provided. The tower space requirements should not exceed 600 gross square feet.

159 66 LANDING CRAFT RAMP (EA)

FAC: 1591

BFR Required: Y

15966-1 No criteria currently exists for this category code.

159 70 DREDGE CONTROL/PUMPING FACILITY (GM)

FAC: 1591

BFR Required: N

15970-1 **GENERAL.** The requirement for this facility is sized based on an engineering analysis for the conditions of the specific location.

160 HARBOR AND COASTAL FACILITIES

160-1 This category group includes all special facilities which may be required for protecting the harbor or coast against military action. This category also includes special facilities for mooring vessels and marine improvements for protecting the harbor land area or coastline from current or wave action and from flood conditions.

161 HARBOR PROTECTION FACILITIES

161-1 This basic category provides facilities for protecting the harbor against military action.

161 20 FIXED NET ANCHORAGE (EA)

FAC: 1611

BFR Required: N

16120-1 **DESCRIPTION.** This Category Code includes such functions as pile clusters and platforms used to support Anti-Terrorism/Force Protection (AT/FP) floating barriers. If a traditional submerged harbor net is used, this type of feature would also be required.

Typically, a Fixed Net Anchorage will require a means to connect and disconnect the floating barrier to allow for ships and other vessels to pass between the piers and wharves and the navigational channel. Barrier handling is typically done by service craft under the control of the Port Operations Department.

161 30 WINCH HOUSE (EA)

FAC: 1611

BFR Required: N

16130-1 **DESCRIPTION.** A winch house is a structure used in control of harbor nets, floating barriers and oil booms.

162 COASTAL PROTECTION FACILITIES

162-1 This basic category provides facilities for protecting the coast against military action.

162 10 GUN EMPLACEMENTS (EA)

FAC: 1499

BFR Required: N

16210-1 **DESCRIPTION.** Space in strategic sites is provided on base for the installation of gun emplacements, including anti-aircraft guns, for use in harbor defense.

163 MOORINGS

163-1 This basic category provides fixed structures for mooring vessels.

163 10 MOORING DOLPHIN (EA)

FAC: 1631

BFR Required: N

16310-1 **DESCRIPTION.** Mooring dolphins consist of clusters of timber, steel and concrete piles in planned patterns and spacing or can be closed structures such as sheet pile, steel or concrete caissons. Mooring dolphins are independent structures that are often placed at the outboard ends of piers or wharves to provide a mooring point that permits tying mooring lines at favorable angles without having to extend the entire pier or wharf structure. Mooring dolphins may have steel or concrete platforms used as pile cap structures and for mounting of mooring fittings. The timber piles are bound and secured by wire rope, shearing blocks, and bolts. Mooring dolphins are often connected to the main berthing pier or wharf by catwalks. Turning dolphins are used to deflect

ships and assist in their alignment as the ships approach and enter a slip. Naval installations with harbor or waterfront facility requirements for mooring of small craft and ships, up to carriers, may plan for mooring dolphins to insure the safety and protection of the vessels. The number, size, and type of dolphins are dependent upon the type of vessels involved, the complexity of the approach to the slip and the requirements for mooring the vessel under prevalent environmental loads.

16310-2 **DESIGN CRITERIA.** For typical dolphin arrangements and design requirements, see Piers and Wharves, UFC 4-152-01. For other technical design information, see Military Harbors and Coastal Facilities, UFC 4-150-06.

163 20 MOORING PLATFORM (EA)

FAC: 1631

BFR Required: N

16320-1 **DESCRIPTION.** A mooring platform is an isolated structure consisting of a timber, steel or concrete deck supported on piling or can be a steel pile, sheet pile or concrete type caisson. Two or more platforms are provided in line for berthing of one or more vessels alongside. Mooring platforms provide facilities beyond those points where wharves or piers cease to function effectively as service or loading areas. Mooring platforms may include catwalks between each platform structure and the wharf. Mooring platforms are also referred to as breasting dolphins and allow a full length berth for large ships without the need for a full length wharf or pier. A berthing camel may be used between fender piles and the moored vessel.

16320-2 **DESIGN CRITERIA.** The mooring platform is shown in general plan and detail in Piers and Wharves, UFC 4-152-01.

163 30 STAKE PILE MOORING (EA)

FAC: 1631

BFR Required: N

16330-1 **DESCRIPTION.** A stake pile mooring consists of a stake pile driven below the surface of the firm bottom of the ocean floor. A chain attached to the stake is used to moor the vessel. The advantages of using stake piles instead of anchors for moorings are that they are fixed anchorage points. The disadvantages are that the mooring lines do not equalize the pulls in a spread mooring; the stake pile, because it is fixed, does not absorb shock energy as well as an anchor; and finally, approval from the authority in charge of channel dredging is necessary before driving stake piles into a bottom. When dredging is required in an area where stake piles are located, there is some hazard of damaging dredge cutters. The holding capacity, size, and other design details of stake piles can only be accurately determined by an analysis of bottom soil borings and field investigations at the site.

16330-2 **BUOY, CHAIN AND ANCHOR TYPE MOORINGS.** Moorings used to tie off bow and stern lines for ships can also be buoy, chain and anchor type of designs.

These systems are equipment (personal property); they are not real property facilities and should not be categorized as stake pile moorings.

164 MARINE IMPROVEMENTS

164-1 This basic category provides structures for protecting the harbor, land area, or coastline from current or wave action and from flood conditions.

164 10 BREAKWATER (LF)

FAC: 1641

BFR Required: N

16410-1 **DESCRIPTION.** A breakwater is a freestanding barrier designed to break up and disperse heavy seas and to shield the waters of a harbor from wave action. Breakwaters are planned where primary protection is necessary to create or shelter a harbor or a basin for vessels from wave action. The type and quantity of breakwater is determined by local design considerations.

16410-2 **DESIGN CRITERIA.** Types of breakwater structures are shown in Piers and Wharves, UFC 4-152-01. For technical design information, see Military Harbors and Coastal Facilities, UFC 4-150-06.

164 20 GROINS AND JETTIES (LF)

FAC: 1641

BFR Required: N

16420-1 **DESCRIPTION.** Groins and jetties are structures built to intercept and deflect currents to control littoral drift and deposit of sand and silt.

16420-1.1 **Definition of Groins.** Groins are generally classified according to the principal construction materials used; that is, steel sheet piling, timber, stone, or concrete. A series of groins extending at right angles or parallel to the shoreline will protect the beaches from erosion. A groin serves to intercept currents that cause littoral drift of sand along a beach and under favorable conditions causes the deposition of sand, so as to reduce shore erosion.

16420-1.2 **Definition of Jetties.** Jetties are planned at harbor entrances and channels to control unstable conditions of silting and deposit of sand caused by river flow or tidal or wave action. A properly located jetty system will encourage scouring and maintain channel depth with a minimum of maintenance dredging. Jetties are similar in design to breakwaters, but are smaller.

16420-2 **DESIGN CRITERIA.** The types and lengths of groins and jetties will vary with local design considerations. Types and applications of groins and jetties are shown

in Piers and Wharves, UFC 4-152-01 and design details are shown in Military Harbors and Coastal Facilities, UFC 4-150-06.

164 30 LEVEES (LF)

FAC: 8714

BFR Required: N

16430-1 **DESCRIPTION.** Levees are earthen embankments designed to protect property from water damage during the flood stage of rivers and/or other high water. The size and length of a levee will vary with local design considerations. Levees may be justified at air installations and at other naval installation where usable property must be protected from water damage.

169 OTHER HARBOR AND COASTAL FACILITIES

169-1 This basic category provides for harbor and entrance control points and signal towers.

169 10 HARBOR ENTRANCE CONTROL FACILITY (EA)

FAC: 1611

BFR Required: N

16910-1 **NET DEPOT.** Permanent installations from military control of a harbor entrance are not planned for peacetime, except that a large paved area may be planned, where appropriate, as a site for layout and assembly of harbor nets and allied equipment. The layout area should be near the waterfront and accessible to mobile cranes for net and equipment handling. The area is known as the net depot and is used for net maintenance and for training in net handling.

16910-2 **FLOATING BARRIERS.** Current AT/FP measures utilize a variety of floating barriers that are considered equipment installations. Specific requirements are determined for each location based on geography, wave action and the types of assets to be protected. See Category Code series 161 and 163 for information related to the installation of floating barriers. The Naval Facilities Engineering Services Center (NFESC) has conducted a number of floating barrier studies and can serve as a valuable planning resource.

170 TRAINING FACILITIES

170-1 This category group covers facilities designated for the service career and reserve training of Navy and Marine Corps personnel. There are two basic categories under this code:

171 TRAINING BUILDINGS and

179 TRAINING FACILITIES OTHER THAN BUILDINGS

171/179-1 There are several specialized facility types such as auditoriums, drill halls, and others. Training facilities for general advancement of Navy/Marine Corps personnel, i.e., educational studies, which are conducted on an individual's own initiative and time, are planned under Category Code 740 88 (Educational Services Office).

171 TRAINING BUILDINGS

171-1 **General.** Facilities in this basic category are identified according to the nature of instruction provided. The major building types are:

171-1.1 **Academic Instruction Building** (Category Code 171 10). This facility provides accommodations for classroom lecture instruction, using chairs with fixed table arms, tables, desks or other similar working surfaces.

171-1.2 **Reserve Training Building** (Category Code 171 15). This facility is utilized for training Navy and Marine Corps Reserves.

171-1.3 **Applied Instruction Building** (Category Code 171 20). This facility is used to accommodate training through the use of equipment and tools such as drafting tables, workbenches, machinery, equipment or functional systems.

171-1.4 **Operational Trainer Space** (Category Code 171 35). This space is required to accommodate highly specialized real-life simulation training that needs specifically designed space within a building or a separate building. The size and configuration of these specialized spaces differ considerably from a typical applied instruction classroom.

171-2 **Space Type.** Training Buildings generally consist of three different types of spaces, classrooms, support and circulation, and service areas. The following is a description of the spaces and their components. See Table 171-1 for space allowances.

171-2.1 Classroom Spaces

171-2.1.1 **General Academic Space.** These classrooms devoted to lecture space are academic instruction classrooms defined under Category Code 171 10. Use Table 17110-1 for space allowances.

171-2.1.2 **Modified Academic Space.** This space consists of a lecture/laboratory combination classroom and is used for both lectures and practical exercises involving hands-on disassembly and assembly of small training aids applicable to the subject matter. A class that requires standard office desks is included in this category. Area includes workspace, circulation, teaching station and book storage. These classrooms are identified under Category Code 171 10.

171-2.1.3 **Workbench Lecture Space.** This space is for an instructional laboratory, the size of which may be only determined on an individual basis. The facility planners have to take into consideration the student/equipment/ instructor ratio which determines the numbers of instructional or test equipment per student station and consequently the space requirements, For example, electronics-related training requires approximately 6 linear feet of workbench resulting in approximately 50 to 55 net SF classroom space per student station, including circulation. Individual justification must accompany EWR submittals.

171-2.1.4 **Space for Hands-on Mockups.** This space is for a classroom in which instruction is given to individual or groups of students on stationary training devices representing all or part of an operating system. The size of this type classroom is generally determined not by the number of students, but by the physical size of the equipment. Figure 17120-1 under Category Code 171 20 provides a formula, which may be used to determine the required net floor space. A single line layout drawing indicating major dimensions should accompany BFR submittals.

171-2.1.5 **Learning Centers.** The learning center is a classroom utilized by students for individual study where training is conducted on a self-paced basis. It is space equipped with study carrels either designed for reading only or equipped with audio-visual training media. Since the self-paced training system has an unstructured time frame (i.e., students may use the facility whenever they have time available), the number of study carrels must be determined individually, the BFR submittal must show these calculations which should be based on the overall number of students requiring such facilities and the estimated number of students which are anticipated to use a learning center at a given time.

171-2.1.6 **Modified Academic Classroom.** This room is equipped with desks or other working surfaces in lieu of standard chairs with fixed tablet arms. Space requirements are 45 net SF per student station, including circulation. Larger areas require justification. These spaces are identified under Category Code 171 10.

171-2.2 **Support Spaces**

171-2.2.1 **Instructor's Work Space.** Facilities should be provided for each instructor to perform his administrative and preparatory duties.

171-2.2.2 **Instructor's Lounge.** The fixed allowance shown in Table 171 A assumes that no more than 10 instructors will be present at one time. Reduce this area proportionally if smaller use is anticipated. An increase in space above the amount indicated requires specific justification.

171-2.2.3 **Student Break Area.** This space should accommodate the average number of students scheduled to have a class recess at any given

time. It can be provided at one location or dispersed in several locations throughout the school building.

171-2.2.4 **Library.** Due to the relative complexity of library operations, required space is broken down as follows:

- **Reading Area.** To estimate the number of persons utilizing this facility, use 20% of the average on board student load.
- **Stack Area.** Allowance given in Table 171-1 is based on 100 volumes per 3 linear feet section, 7.5 feet high, or 15 volumes per net square feet of floor area.
- **Media Storage.** Allowance given in Table 171-1 is based on storage of 424 DVDs or 260 VHS tapes in a section of shelving 3 feet long by 6 feet high in a space 3 feet wide. The width of this floor space provides for the cabinet depth plus half the width of an access aisle.
- **Staff Area.** Includes files, administration, reproduction space and material preparation area.

171-2.2.5 **Administrative Space.** This is space required for functions related to overall administration of the training facility in question and the allowances are governed by the number of administrative personnel. Planning procedures and net space allowances are the same as for Category Code 610 10 (Administrative Office), planning method 2 (detailed planning factors). The broad planning factor of 162.5 gross SF per occupant, under Category Code 610 10, may not be used because it would duplicate some of the support space allowances already provided for under this Category Code series 171.

171-2.2.6 **Training Aid Storage.** The space allowance is shown on Table 171-1.

171-2.2.7 **Other Support Spaces** not listed above must be identified separately and specific justification should accompany BFR submittals.

171-2.3 **Service Areas and Circulation.** These areas represents all spaces not in direct support of the training function, including walls, rest rooms, mechanical equipment, halls and corridors.

171-3 **PLANNING PROCEDURES**

Choose one of the following three methods to compute classroom net square feet space requirements.

171-3.1 **Average On Board.** This method is straightforward in the calculation of classroom space requirements. The formula requires a minimum amount of information as follows:

171-3.1.1 **Number of Students.** Total number of students per year for each course.

171-3.1.2 **Number of Days.** Total number of days (duration) to complete the course.

171-3.1.3 **Square Feet.** The proper choice of square feet per student from Table 171-1 based on the type of classroom instruction.

171-3.2 **Classroom Scheduling Method** The method that is preferred sometimes because it's easier to picture classrooms with a set number of students and a drawn schedule. The schedule shows an overall view of the student loading per month and gaps in classroom scheduling. The following minimum information is needed:

171-3.2.1 **Number of Students.** The number of students planned for each classroom.

171-3.2.2 **Course Time.** The duration of each course and the number of times taught throughout the year.

171-3.2.3 **Classroom Uses.** A decision on whether or not the classroom can be used for other courses.

171-3.3 **Student Time Distribution Method.** This method uses a more involved accounting system to estimate time expenditures for different types of course instruction. The method shows a detail study and breakdown of planned time distribution in labs, lectures and special applications classes. More information is required than in the other two methods.

In addition to computing classroom space requirements, develop the requirements for Support Spaces separately. Convert final totals to gross square feet.

SPECIAL NOTES FOR PLANNING PROCEDURES

1. Any construction project, regardless of funding source, submitted for authorization must be accompanied by detailed supporting documentation (broad planning factors cannot be used in lieu of detailed analysis).
2. Planning for training buildings shall be based on maximum utilization of available classrooms. To this end, the number and sizes of classrooms shall be determined on the basis of a detailed study encompassing curricula, group sizes, schedules, security and proximity requirements, and/or any other pertinent aspects. It is recognized that a number of subjects, especially in the applied instruction field,

require extensive training aids or special classroom configurations. Every attempt must be made, however, to minimize the number of such single subject or “dedicated” classrooms, especially in those cases where their use would be relatively infrequent. Cross-scheduling of classroom use must be considered on an installation-wide basis, crossing organizational boundaries if necessary.

3. As a general rule, most training buildings will consist of a mixture of different types of instructional space (normally a combination of academic and applied instruction). For buildings of this type, the specific applicable criteria must be utilized to plan the facility in question even though a resulting project may carry only a single Category Code (171 10 or 171 20). For example, an applied instruction building (Category Code 171 20) contains academic classrooms utilized to teach basic or familiarization aspects of an applied instruction curriculum. In such case, academic classrooms are sized using code 171 10 criteria, although on planning documentation, this space will eventually be combined with the figures for the applied instruction (Category Code 171 20) portions of the facility.

171-4 **COMPUTATION METHODS FOR COMPUTING CLASSROOM SPACE**

171-4.1 **Average On Board**

171-4.1.1 Use Figure 171-1 and list the courses of instruction conducted by the Activity. List the requirements in separate categories (e.g. general academic, lab-lecture, etc).

171-4.1.2 Show the Course Data Processing Code (CDPC), course title, and other requested information. The columns of information are defined at the bottom of the table. Information is available in the Master Course Reference File (MCRF) of the Navy Integrated Training Resources and Administrative System (NITRAS) and other sources.

171-4.1.3 Use the AOB formula to calculate the number of students per class.

171-4.1.4 Based on the type of instruction, select the proper square feet per student from Table 171-1.

171-4.1.5 Calculate the Required NSF for each course.

171-4.1.6 Add the Required NSF column to obtain the total requirements.

171-4.2 **Classroom Scheduling Method**

171-4.2.1 Use Figure 171-2 and list each course.

171-4.2.2 Assume the courses meet all day. If a course meets during the AM hours in a room and a different course can meet in the same room during PM hours, assume one room requirement.

171-4.2.3 Draw a line through the number of weeks the course is held each time during the year.

171-4.2.4 Show the week the course begins and ends each time. Show the number of students planned for each course above the course duration line.

171-4.2.5 After the class scheduling is drawn, use Figure 171-3 to organize the requirements. List each course, type of class space, number of students for each classroom and the square feet used to calculate requirements obtained from Table 171-1.

171-4.2.6 Determine whether or not the classroom requirement should be dedicated strictly for the course or if other courses can be scheduled in the same room.

171-4.2.7 Use one of the following formulas to calculate space requirements and show the calculation in Figure 171-3 Column E or F.

171-4.2.8 Total Classroom requirement is the sum of Columns E and F. Separate the totals into classifications (e.g., total general academic, lab-class, etc., space).

Dedicated Classroom - This classroom has permanently installed demonstrations, mock-ups, laboratory equipment, or special teaching aids. The room is usually not conveniently set-up for teaching other courses.

$$\boxed{\begin{array}{c} \text{Dedicated} \\ \text{Classroom} \\ \text{Requirement} \\ \text{NSF} \end{array}} = \boxed{\begin{array}{c} \text{No. Pupils per} \\ \text{Course in} \\ \text{Classroom} \end{array}} \times \boxed{\begin{array}{c} \text{Table 171-1} \\ \text{Type Class} \end{array}}$$

Partial Classroom Requirement - This condition applies to courses that can meet in general classroom areas or courses that meet less than 60% of a 250-day school year.

$$\boxed{\begin{array}{c} \text{Partial} \\ \text{Classroom} \\ \text{Requirement} \\ \text{NSF} \end{array}} = \boxed{\begin{array}{c} \text{No. Pupils} \\ \text{per Course in} \\ \text{Classroom} \end{array}} \times \boxed{\begin{array}{c} \text{Table 171-1} \\ \text{Type Class} \\ \text{Sq. Ft.} \end{array}} \times \boxed{\begin{array}{c} \text{Total Course} \\ \text{Days per} \\ \text{Year} \end{array}}$$

School Year = 250 class days per year.

171-4.3 Student Time Distribution Method

171-4.3.1 Use Figure 171-4 to enter information.

171-4.3.2 Organize the list of planned courses according to the anticipated number of students in each classroom.

171-4.3.3 Group the courses in descending class sizes (e.g. classes with 40, 30, 20, students etc.) in Columns A and B.

171-4.3.4 Show the course duration in number of weeks. Use fractional weeks as necessary.

171-4.3.5 In Columns E, G, I, and K show the estimated percentage of time spent in each type of class (e.g., 50% lecture, 50% lab).

171-4.3.6 In Columns F, H, J, and L, show the equivalent weeks per year for the types of instruction (e.g., Col F = (C) x (D) x (E))

171-4.3.7 Total the weeks in Columns F, H, J, and L.

171-4.3.8 Organize the data according to types of instruction and class sizes as shown in the example Figure 171-4.

171-4.3.9 Calculate the classroom sizes from the square feet allowances per student shown in Table 171-1. For example, to calculate a general academic classroom for 8 students, use 22 sq ft from Table 171-1, which refers user to Table 17110-1.

171-4.3.10 Therefore, $8 \times 22 = 176$ sq ft. Use the same calculation method for labs and the other types of classroom spaces.

171-4.3.11 The totals in the Classroom Computation Schedule show the number of classrooms and net square feet.

Figure 171-1. Classroom Space Requirement Computation

Course CDP	Course Short Title	Duration in Days (DD)	Annual Frequency (AF)	Pupils Per CL (S)	Annual Input (AI)	Student AOB *	NSF Per Student (NSF)	Requirement Net Area **
Total Student AOB and Total Requirement in Net SQ. FT.								

$$* \text{ Student Average on Board (AOB)} = \frac{\text{Duration (DD)} \times \text{Annual Input (AI)}}{250 \text{ (Classroom Days Per Year)}}$$

$$** \text{ Required NSF Area} = \text{AOB} \times \text{NSF} \times 1.5$$

Round all Fractions to the next highest whole number
 School year = 250 class days

- NSF = Select proper square feet per student from Table 171-1 according to type of installation
- CDP = Course Data Processing Code
- DD = Duration of course in actual classroom days
- AF = Number of times course is taught per year
- AI = Number of students trained annually AI = (AF) x (S)
- 1.5 = A utilization factor required to compensate for the inability to completely schedule classes and fully use classroom capacity.

Figure 171-2. Classroom Scheduling Method Type of Training Space: Various

Course Title	JAN	FEB	MAR	APR	MAY	JUN	JUL	AUG	SEP	OCT	NOV	DEC	Remarks
AN/xyz	15		15		15		15		15		15		
BB Applied	10		10		10		10		10		10		
CD Lab		6		6		6		6		6		6	
Total Student Loading/Month	25	16	25	16	25	16	25	16	25	16	15	6	

Figure 171-3. Calculation Summary – Scheduling Method

(A) Course Desc.	(B) Type of Class	(C) No. of pupils per class	(D) Sq. Ft. Used Table 171-1	(E) Dedicated Room Sq. Ft.	(F) Partial or Gen Class Sq. Ft.
AN/xyz	Lecture	15	22		330
BB Applied	Mod Lec	10	30		300
CD Lab	Lab	6	45	270	
Totals				270	630

Figure 171-4. Course Data and Student Time Distribution

Course Title (arranged by decreasing size)	Class Size	Frequency of Class per Year	Duration of Class in Weeks	% Time in General Academic classroom or Lecture Space	Weeks per Year (F=CxDxG)	% Time in Modified Academic Classroom or Modified Lecture Space	Weeks per Year (H=CxDxG)	% Time in Work-Bench Type Space	Weeks per Year (J=CxDxI)	% Time in Hands-On-Mockups	Weeks per Year (L=CxDxK)	% Time Elsewhere
A	B	C	D	E	F	G	H	I	J	K	L	M

Explanation:

- Column B - Projected student loading for the designated class
- Column C - Number of times per years course is offered
- Column D - Individual course duration in weeks
- Column E G I K - Percentage of actual student’s instructional time spent in the various classroom types.
- Column F H J L - Requirements of that particular class room size and type by number of weeks.

Example Figure 171-4. Course Data and Student Time Distribution

Course Title (Arranged by decreasing class size)	<i>(NOTE: Same column headings as Figure 171-4)</i>											
A	B	C	D	E	F	G	H	I	J	K	L	M
AAA-0000	40	25	-4	100%	10							
ABC-XXXX	40	10	2	100%	20							
40 PN Totals					30							
DEF-XXXX	20	6	2	50%	6	50%	6					
GHI-YYYY	20	3	10	100%	36							
JKL-1234	20	5	10	50%	25	20%	10			30%	15	
MNO-6250	20	2	5	25%	3	50%	5	25%	3			
PQR-1111	20	50	0.6	100%	30							
29 PN Totals					100		21		3		15	
ABD-0001	10	5	10	100%	50							
ABD-0002	10	2	20	50%	20	50%	20					
ABD-0003	10	25	1	100%	25							
ABD-0004	10	50	0.4	100%	20							
10 PN Totals					115		20					

Explanation:

Column B - Projected student loading for the designated class

Column C - Number of times per year course is offered

Column D- Individual course duration in weeks

Columns E G I K - Percentage of actual student's instructional time spent in the various classroom types

Columns F H J L - Requirements of that particular classroom size and type by number of weeks

Classroom Computations

Refer to Figure 171-4

Class Size	Total Weeks Per Year Required	/	50 Weeks Per Year	=	Computed Classroom Requirement *	Actual Classrooms Required **		Size ***	=	Net
								Square Feet		
General Academic Classroom or Lecture Space										
40 PN	30	/	50	=	0.6	1 Each	X	800 NSF	=	800
20 PN	100	/	50	=	2.0	2 Each	X	440 NSF	=	880
10 PN	115	/	50	=	2.3	3 Each	X	220 NSF	=	660
Total						4.9	6 Each			
Modified Academic Classroom or Modified Lecture Space										
20 PN	21	/	50	=	0.4	1 Each	X	20 PN x 45 NSF	=	900
10 PN	20	/	50	=	0.4	0				
Total						0.8	1 Each			3240 NSF

- Workbench type space (Use Individual Justification)
- Hands-on-Mock-ups (Use Formula in Figure 17120-1)

* Allows for Holiday stand downs and scheduling flexibility

** Actual classroom required must equal or exceed computed classroom requirement. Number of required classroom must take into account the excess time available in larger size rooms, i.e., smaller classes can use available excess time in larger rooms.

*** Size data follows Table 171-1

Table 171-1. Space Allowances for Instruction Facilities

Type of Space	Maximum Allowances
1. CLASSROOM SPACE	
a. General Academic	Use Table 17110-1 allowances
b. Modified Academic Space	30 net SF per student station
c. Lecture-Lab Space	45 net SF per student station
d. Modified Academic with office desks	45 net SF per student station
c. Workbench Type Space	Individual justification required
d. Hands-On Mockup Space	Use formula given in Fig. 17120-1
e. Learning Centers	40 net SF fixed allowance
2. SUPPORT SPACE	
a. Instructor's Work Space	60 net SF per instructor
b. Instructor's Lounge	450 net SF fixed allowance
c. Student Break Area	6 net per student
d. Library	
(1) Reading Area	25 net SF per person
(2) Stack Area	6.6 net SF per 100 volumes
(3) Media Storage	9 net SF per 424 DVDs or 260 VHS tapes
(4) Media Viewing Room	100 net SF fixed allowance
(5) Staff Area	10% of sum of reading stack, film storage and viewing areas
e. Administrative Space	Use category code 610 10 detailed criteria
f. Training Aid Storage	1.5 net SF per student station
g. Other Support Spaces	Individual justification required
3. CIRCULATION AND SERVICE AREAS	
(Net to Gross Conversion)	Multiply NSF by 1.33

Note: Student station is defined as a classroom seat or shop workbench area designated to accommodate one student.

171 10 ACADEMIC INSTRUCTION BUILDING (SF)**FAC: 1711****BFR Required: Y**

17110-1 A facility dedicated entirely to academic instruction will seldom be planned. In most cases, instruction of this type will be part of another training function, such as at a Service School or conducted in some other type of applied instruction building. The criteria for this type facility are based on net classroom square feet per student seat.

For planning purposes, academic classrooms can be divided into two general categories:

17110-1.1 **General Academic Classroom** - is one which supports approved training programs and provides accommodations for classroom lecture instruction, using standard chairs with fixed tablet arms or a similar seating configuration providing the student a writing surface and book depository. An instructor station is provided, with space for the use of portable training aids. The individual general academic classroom sizes in net square feet (i.e., within the interior walls of the room), as dictated by the required number of seats, shall not exceed the figures given in Table 17110-1.

17110-1.2 **Modified Academic Classroom** - is one which is equipped with desks or other working surfaces in lieu of standard chairs with fixed tablet arms.

17110-2 Planning Steps

17110-2.1 The number and size of individual classrooms must be determined in accordance with the general guidelines given under the topic Planning Procedures in the preceding general section for Basic Category 171.

17110-2.1.1 Gross Square Feet - Broad Planning

The space allowances for general and modified academic classrooms represent net classroom space only. The requirements for supporting spaces must be calculated separately in order to obtain gross SF building area. This may be done by either one of the two alternate methods:

- In the absence of detailed data during early stages of planning, the gross SF building area (including all necessary support space) shall be computed as follows:
 - In cases where the training building is composed entirely of general academic classrooms, use the broad planning factor of 45 gross SF per student station for the entire building.

- In cases where some or all of the classrooms are of the modified academic classroom type, by using the broad planning factor of 75 gross SF per student station for the entire building.
- In cases where, within an academic training facility, a number of classrooms must be modified to accommodate working surfaces different than standard chairs, the net area for such modified academic classrooms may be increased. For instance, modified academic classrooms (with standard office desks) will require approximately 45 net SF per student station, including circulation. Larger increases will require specific justification.
 - Maximum consideration must be given to provide a variety of classroom sizes in order to optimize space utilization.

**Table 17110-1
Space Criteria for General Academic Classrooms**

No. of Seats	Sq. Ft. per Seat
20	22
30	21
40	20
50	19.5
60	19
70	18.5
80	18
81 to 90	17
91 to 100	16
101 to 120	15.5
121 to 140	15
141 to 160	14.5
161 to 180	14
over 180	14

171 15 NAVY AND MARINE CORPS RESERVE TRAINING (SF)**FAC: 1714****BFR Required: Y**

NOSC Space Program spreadsheet, located at: <https://www.wbdg.org/ffc/dod/unified-facilities-space-program-sustainability-spreadsheets>

Design Criteria: FC 4-171-06N “Navy Operational Support Center”
<https://www.wbdg.org/ffc/dod/unified-facilities-criteria-ufc/fc-4-171-06n>

17115-1 **DEFINITION.** Navy and Marine Corps Reserve Centers provide training, organizational and administrative support to Reserve units and their supporting functions. This category code refers to the Reserve Training center only. Criteria for other facilities which support the Reserve unit personnel (e.g., Bachelor Housing, Dining, Aircraft Maintenance Hangars, etc.) are not included in this section and follow the same criteria as active duty counterparts. Refer to Appendix A of this UFC for a function / category code cross-reference.

17115-2 **LOCATION:** In many instances, the Reserve Center may be located outside of the perimeter of a formal DoD Installation. In these cases, it is important to refer to UFC 4-010-01 “DoD Minimum Antiterrorism Standards for Buildings” for guidance relative to the necessary Force Protection elements to consider while planning new Reserve unit facilities and renovation of existing facilities.

17115-3 **NAVY OPERATIONAL SUPPORT CENTER (NOSC):** A facility for use by Naval Reserve Units for training and organizational requirements.

17115-3.1 **Capacity.** The space allowances for a Naval Operational Support Center shall be determined on the basis of the **maximum weekend drill population**, not total drill population numbers. Other important factors determining capacity include the number of Full Time Staff (FTS) and the total number of Reserve Units utilizing the drill site.

17115-3.2 **Joint Space Allowance.** When two or more Services are combined into a single joint reserve facility, 50% of the smallest individual Service requirements for medical, janitorial, and male and female toilet areas shall be added to the largest individual Service’s requirement for each respective area.

17115-3.2 **Space Criteria.** The gross square footage allowance for Administrative, Medical, Unit Area and Drill Hall spaces in the NOSC are obtained from the NOSC Space Program spreadsheet which can be found at <https://www.wbdg.org/ffc/dod/unified-facilities-space-program-sustainability-spreadsheets>.

Optional additive spaces for specific Unit requirements are provided in Tables 17115-1 through 17115-6, which should be added to the net results provided by the

space program spreadsheet (if applicable) and increased by the 35% NTG factor for circulation, etc. (For Marine Corps Reserve Centers, refer to paragraph 17115-5. The space program spreadsheet does not apply to the Marine Corps Reserve Centers).

17115-4 **NOSC OPTIONAL ADDITIVE SPACES:** In specific cases, Reserve units are authorized additional space for applied training, simulators, or maintenance when authorized equipment is present at reserve centers. The following tables are provided as examples of additional requirements.

Table 17115-1 Additive Space Criteria for Cargo Handling Battalion (NRCHB)

Cargo Handling Battalion (NRCHB):		
Administrative/Training Facility	@ Reserve Readiness Sites (RSS)	@ NOSC
Classrooms	1600 NSF	
Toilets/Showers	700 NSF	
Administrative	2800 NSF	230 NSF
Locker Room	735 NSF	
Storage	1500 NSF	700 NSF
Rigging Shop	325 NSF	325 NSF
Total for Admin./Training Facility (net)	7660 NSF	1255 NSF
Vehicle Maintenance Facility (GSF)		2910 GSF
Vehicle Storage (GSF)		1820 GSF
Total for Vehicle Maint.functions (gross)		4730 GSF
Ship mock-up (1 each) (see note 1)	3700 SF	3700 SF
Simulated Pier (0.25 Acre) (see note 1)	1172 SY	1172 SY
Organizational Vehicle Parking	680 SY	680 SY
Staging Area (paved)	1 ac	1 ac
Lay down Area (paved)	556 SY	556 SY
Training Site (see note 2)	5 ac	5 ac

NOTES

- 1 The ship mock-up and simulated pier are authorized only when there are no Maritime Administration (MARAD) ship or other ships available for training.
- 2 Five (5) acres of constructible land are required only if a MARAD ship is not available and the mock-up trainer is constructed. Actual requirements will be developed as a result of Master Planning and site layout.

Table 17115-2 Additive Space Criteria for Mobile Mine Assembly Group (MOMAG)

Mobile Mine Assembly Group (MOMAG):		
	@ RSS	@ NOSC
Vault	-	18 SF
Shop	-	400 SF
TOTAL (net)		418 SF

Table 17115-3 Additive Space Criteria for Expeditionary Logistics Support Force (NRELSF)

Expeditionary Logistics Support Force (NRELSF):		
	@ RSS	@ NOSC
Administration/Training	8100 SF	-
TOTAL (gross)	8100 SF	-
POV parking	980 SY	-
TOTAL	980 SY	-

Table 17115-4 Additive Space Criteria for Sea-Air-Land (SEAL) Unit

Sea-Air-Land (SEAL) Unit:		
Diving Equipment Maintenance and Storage	-	390 SF
Boat Storage	-	250 SF
Locker Room	-	300 SF
TOTAL (net)	-	940 SF

Table 17115-5 Additive Space Criteria for Inshore Boat Unit (NRIBU)

Inshore Boat Unit (NRIBU):		
	@ RSS	@ Reserve Centers
Classroom (Only if not co-located at a Center)	726 SF	
Administration/Training Support	1521 SF	345 SF
Shower (2 each for male and female @ 20 SF each)	80 SF	
Locker (120 SF male plus 60 SF female)	180 SF	180 SF
Storage	800 SF	800 SF
Armory	45 SF	45 SF
TOTAL (net)	3352 SF	1370 SF
Boat Storage Area	1205 SF	1205 SF
TOTAL (gross)	1205 SF	1205 SF
Organizational Vehicle Parking	250 SY	250 SF
Private Owned Vehicle Parking (POV)	1008 SY	1008 SY
TOTAL	1258 SY	1258 SY

Mobile Diving and Salvage Unit (NRMDSU):		
Interior Storage	860 SF	860 SF
SCUBA Locker	240 SF	240 SF
Shop	400 SF	400 SF
Diver Personnel Lockers	225 SF	225 SF
Showers/Heads (Do not include if co-located at a Center)	225 SF	
Multipurpose Area (Do not include if co-located at a Center)	280 SF	
Admin/Office (Do not include if co-located at a Center)	540 SF	
Flammable Storage (56 SF portable bldg)	0 SF	0 SF
TOTAL (net)	2800 SF	1725 SF

17115-5 **MARINE CORPS RESERVE CENTER:** Space allowances for these facilities will accommodate the range of personnel listed as column headings shown in Table 17115-7 (e.g. 50 to 150 persons, etc.). Square footages for each range are based upon the design capacity listed at the top of the column. To determine the facility requirement, choose the range in Table 17115-7 that corresponds to the units projected personnel loading (found in the USMC Table of Organization). Units with loading outside of the range of Table 17115-7 require special justification, and the user should consult the Naval Facilities Engineering Command or Headquarters, USMC for planning assistance.

Tables 17115-7, 17115-8, and 17115-9 are to be used only as a guide. Changes to individual functions are acceptable given adequate justification. Tables 17115-7, 17115-8, and 17115-9 Special Requirements, are not intended for all centers and require approval from Headquarters, USMC and Commander, Marine Forces. For further assistance, see other category codes, Architectural Design Standards or contact Naval Facilities Engineering Command or Headquarters, USMC.

**Table 17115-7 Space Criteria For Marine Corps Reserve Centers
Training and Administrative Building**
(All Numbers are Net Square Feet Unless Noted)

Functional Area	Drill Strength 50 to 150	Drill Strength 151 to 250	Drill Strength 251 to 350	Drill Strength 351 to 450
A) JOINT USE SPACE (See Table 17115-7(a) for space derivation data)				
Drill Hall	5,850	5,850	6,300	6,750
Classrooms	1,500	2,500	3,500	4,500
Medical Examination	650	650	650	650
Conference Room	225	375	525	675
Janitorial Space	200	200	200	200
Toilets/Showers: Male	400	500	600	700
Toilets/Showers: Female	250	300	350	450
Day Locker Room (Marines)	200	350	475	600
Lounge	200	300	400	500
Mechanical Equipment	400	500	600	700
Subtotal of Part A: Joint Use Space	9,875	11,525	13,600	15,725

**Table 17115-7 Space Criteria For Marine Corps Reserve Centers
Training and Administrative Building**
(All Numbers are Net Square Feet Unless Noted)

Functional Area	Drill Strength 50 to 150	Drill Strength 151 to 250	Drill Strength 251 to 350	Drill Strength 351 to 450
-----------------	--------------------------------	------------------------------------	------------------------------------	------------------------------------

B) EXCLUSIVE USE SPACE (See Table 17115-7(a) for space derivation data)				
Administrative Offices	2,500	3,100	3,900	4,700
Conference Room	350	450	550	650
Recruiting	400	400	400	400
Training Aids (Training Storage/Storage)	100	100	100	100
Multi-Media Center/LAN Control Center	25	25	25	25
IMST Trainer	1,050	1,050	1,050	1,050
Armory/Security Vault	800	800	800	800
Shops-Comm. Maintenance	700	700	700	700
Lockers (Double Size)	1,575	2,625	3,675	4,725
Supply Storage	3,500	4,000	4,500	5,000
Exercise / Fitness Center	900	1,500	2,025	2,600
Subtotal of Part B: Exclusive Use Space	11,900	14,750	17,725	20,750

**Table 17115-7 Space Criteria For Marine Corps Reserve Centers
Training and Administrative Building**
(All Numbers are Net Square Feet Unless Noted)

C) SPECIAL REQUIREMENTS				
Special requirements are not included in all Reserve Centers. Each function is justified by a unit's particular mission. These functions are to be part of the Reserve Center interior floor plan (should have 25% added for walls and circulation accordingly). Each function must be approved by Headquarters, USMC and Commander, Marine Forces Reserve. (See Table 17115-7(a) for space derivation data)				
Functional Area				All drill strengths
Food Service Galley				400
Photo Unit (Dark Room)				100
Mobilization Station				500
Food Service Storage				700
Classified Material Storage				200
Communications/Electronics Shop				700
Medical Logistics Storage				5,000
Embark Storage				800
Dental Officer Office				180
Medical Officer Office				180
Subtotal Part C. Special Requirements Space				

Total of Parts A, B, & C	
Net to Gross Factor for Walls, Circulation, & Common Areas (25%)	
Total GSF Requirement for Reserve Center	

Table 17115-7(a) Derivation of Space Allowances for Table 17115-7

A. JOINT USE SPACE	
Assembly Hall (Navy)/Drill Hall (Marine)	Minimum space is based upon full size basketball court. Space should accommodate 100% of the drill population for all hands events: equipment staging area, unit formations and physical fitness.
Classrooms	Size based upon 50% of drill population being in class at any given time, to include space for computers and audio/visual equipment (use 20 SF per student).
Medical Examination	Fixed size.
Conference Room	Size based upon 10% of drill population (use 15 SF per person)
Janitorial Space	Fixed size consistent with architectural standards.
Heads/Showers, Male	Size based upon OSHA standards of 1 toilet for each 10 personnel (with the appropriate mixture of toilets/urinals) and 1 shower head for each personnel (up to a maximum of 35 shower heads)
Heads/Showers, Female	Size based on minimum of 5% of drill population is female (1 toilet for each 10 personnel).
Lounge	Fixed size.
Day Locker Room (Marine)	Size based on 50% of drill population requirement for 1 day locker with lockers double stacked (each locker and bench is 5.3 SF).
B. EXCLUSIVE USE SPACE	
Administrative Offices	Variable size based on 18-12% of the drill strength (use 90 SF per person)
Conference Room	Size based upon 100% of active duty T/O (use 15 SF per person)
Recruiting	Fixed size.
Training Aid Storage	Fixed size.
LAN Control Center	Fixed size.
ISMT Training Room	Minimum size per training unit is 1,050 SF with a minimum ceiling height of 10 feet (each additional trainer requires another 1,050 SF).
Armory/Security Vault	Minimum size is 800 SF (for additional guidance use Cat Code 143-45). Size may increase based on units T/E.
Communication Maintenance Shop	Minimum size is 700 SF (for additional guidance use Cat Code 217)
Lockers	Size based on 100% of drill population requirement for 1 double-size locker per person.
Exercise/Fitness Center	Fixed size based on 15% of drill population working out at any one time (38.5 SF per person reference MIL-HDBK 1037/8).
Supply Storage	Minimum size listed with a minimum ceiling height of 20 feet (for additional guidance use Cat Code 441-10)

Table 17115-7(a) Derivation of Space Allowances for Table 17115-7 (Cont'd)

C. SPECIAL REQUIREMENTS	
Food Service Galley	Fixed size (400 SF)
Photo Unit (Dark Room)	Fixed size (100 SF)
Mobilization Station	Fixed size (500 SF)
Food Service Storage	Fixed size (700 SF)
Classified Material Storage	Fixed size (200 SF)
Communications/Electronics Shop	Fixed size (700 SF)
Medical Logistics Storage	Fixed size (5,000 SF). Should have a roll-up door for vehicle access
Embark Storage Shed	Fixed size (800 SF). Structure will have a vehicle access with roll-up door.
Dental Officer Office	Fixed size (180 SF). Only for dental battalions.
Medical Officer Office	Fixed size (180 SF). Only for medical battalions.

Table 17115-8 Space Criteria for Marine Corps Reserve Centers Vehicle Maintenance Facility

VMF Type	CCN	Type	Space (SF)
<i>Select a type of VMF based on the Vehicle Maintenance Facility criteria. (See Table 17115-8(a) for space derivation data).</i>			
Combat Vehicle Maintenance Facility	214-10	Type A	1,653 SF
		Type B	2,603 SF
		Type C	4,603 SF
		Type D	4,403 SF
		Type E	5,303 SF
		Type F	6,350 SF
		Type G	6,953 SF
VMF Type	CCN	Space Formula	Space (SF)
Automotive Vehicle Maintenance Facility	214-20	___ # of Bays x 480 sqft/bay	___ SF

Table 17115-8(a) Derivation of Space Allowances for Table 17115-8

TYPE	SMALL BAYS		MEDIUM BAY		LUBE/PM BAY		LARGE BAY		GENERAL SPACE	MEZZANINE STORAGE	TOTAL (NET SF)
	# OF BAYS	SIZE	# OF BAYS	SIZE	# OF BAYS	SIZE	# OF BAYS	SIZE			
A	1	560	0	640	0	800	0	1,456	462	300	1,322
B	2	560	0	640	0	800	0	1,456	562	400	2,082
C	1	560	2	640	1	800	0	1,456	602	440	3,682
D	3	560	0	640	1	800	0	1,456	602	440	3,522
E	2	560	2	640	1	800	0	1,456	602	440	4,242
F	0	560	0	640	1	800	2	1,456	788	580	5,080
G	2	560	3	640	1	800	0	1,456	942	780	5,562

Notes - Table 17115-8

- 1) Total square footages are interior, functional space requirements. For total useable square footages, add mezzanine storage requirements. Mezzanine storage is to be constructed with ladder/stair access and removable safety rails over offices, tool rooms and heads.
- 2) Total gross square footages include 25% for walls and circulation.
- 3) The Lube/Preventative Maintenance Bay should be a separate bay, ideally with an air compressor lift vice a hydraulic lift. This bay should not be an exposed pit due to environmental concerns.
- 4) The Automotive Vehicle Maintenance Facility (Cat-Code 214-20) shall be 480 gross square feet, or 16' by 40' as directed by the P-80.

Table 17115-8(a) Derivation of Space Allowances for Table 17115-8 (cont'd)

TYPE A: Facility will not normally be incorporated into Marine Reserve Centers because their limited size does not allow for flexibility. Function breakdown is as follows:

SPACE	SIZE (SF)
Maintenance Bays	560
Flammable Storage	64
Tool Room	110
Head	80
Office Space	110
Maintenance Publications	98
Mezzanine	300
Total Useable Space	1,322
Gross Space	1,653

TYPE B: Function breakdown is as follows:

SPACE	SIZE (SF)
Maintenance Bays	1,120
Flammable Storage	64
Tool Room	160
Head	100
Office Space	140
Maint Publications	98
Mezzanine	400
Total Useable Space	2,082
Gross Space	2,603

Type B Units
Infantry Co/Bn
Supply Co/Bn
Recon Co/Bn
Medical Co/Bn
Dental Co/Bn
H&S Co
MP Co

Table 17115-8(a) Derivation of Space Allowances for Table 17115-8 (cont'd)

TYPE C: At least one small and one medium bay will be drive through, cost and space permitting. An overhead crane should be installed for the following types of units: AAV Co/Bn, LAR Co/Bn, and Maintenance Co/Bn. Function breakdown is as follows:

SPACE	SIZE (SF)
Maintenance Bays	1,840
Lube/PM Bay	800
Flammable Storage	64
Tool Room	200
Head	100
Office Space	140
Maint Publications	98
Mezzanine	440
Total Useable Space	3,682
Gross Space	4,603

Type C Units
Engineer Co/Bn
AAV Co/Bn
LAV Co/Bn
Maint Co/Bn
LSB Co/Bn

TYPE D: At least two small bays will be drive through, cost and space permitting. Function breakdown is as follows:

SPACE	SIZE (SF)
Maintenance Bays	1,680
Lube/PM Bay	800
Flammable Storage	64
Tool Room	200
Head	100
Office Space	140
Maint Publications	98
Mezzanine	440
Total Useable Space	3,522
Gross Space	4,403

Type D Units
Artillery Btry/Bn
ANGLICO
Truck Co
TOW Co
Comm Co/Bn
LAAD Bn

Table 17115-8(a) Derivation of Space Allowances for Table 17115-8 (cont'd)

TYPE E: At least one small bay and one medium bay will be drive through, cost and space permitting. Function breakdown is as follows:

SPACE	SIZE (SF)
Maintenance Bays	2,400
Lube/PM Bay	800
Flammable Storage	64
Tool Room	200
Head	100
Office Space	140
Maint Publications	98
Mezzanine	440
Total Useable Space	4,242
Gross Space	5,303

Type E Units
LAAM Bn
Engineer Supt Co
Collocated Units

TYPE F: At least one large bay and one medium bay will be drive through, cost and space permitting. An overhead crane should be installed. Function breakdown is as follows:

SPACE	SIZE (SF)
Maintenance Bays	2912
Lube/PM Bay	800
Flammable Storage	64
Tool Room	300
Head	100
Office Space	180
Maint Publications	98
Tank Skirt Storage	46
Mezzanine	580
Total Useable Space	5,080
Gross Space	6,350

Type F Units
Tank Co

Table 17115-8(a)
Derivation of Space Allowances for Table 17115-8 (cont'd)

TYPE G: At least one small and one medium bay will be drive through, cost and space permitting. Function breakdown is as follows:

SPACE	SIZE (SF)
Maintenance Bays	3,040
Lube/PM Bay	800
Flammable Storage	64
Tool Room	400
Head	100
Office Space	280
Maintenance Publications	98
Mezzanine	780
Total Useable Space	5,562
Gross Space	6,953

Type G Units
MWSS
Engineer Intensive Collocated Units

**Table 17115-9 Space Criteria for Marine Corps Reserve Centers
Special Requirement Space Allowance**

SPECIAL REQUIREMENTS –					
Special requirements are not included in all reserve centers, and are justified by a unit's particular mission.					
PART I (GROSS SQUARE FEET)					
Each function must be approved by Headquarters, USMC and Commander, Marine Forces Reserve. Although these functions are located with the reserve center, for costing & scoping purposes they are not included in the 171-15 Category Code. Use appropriate Category Code unit cost. See "Derivation of Special Requirement Space Allowances for Table 17115-9" for space requirement derivation data.					
Function	Cat. Code		Calculation	Scope	UOM
Indoor Pistol Range	171-50			900	SF
Rappelling Tower	179-50			400	SF
Tank, Combat Training Pool	179-55			4,200	SF
Parachute and Survival Equipment Shop	211-75			3,670	SF
Optics Shop	213-50			500	SF
Carpenter Shop	213-56			800	SF
Boat Shop	213-58			2,400	SF
Scuba Locker	213-68			250	SF
Field Maintenance Shop (Comm/Elect)	217-30			3,700	SF
Instrument Calibration Shop	218-45			3,600	SF
Boat Storage Shed	441-35			1,700	SF
Vehicle Holding Shed	214-40	___ # of tactical vehicles	___ # of bays (one per 30 vehicles) x 800 SF/bay =	___	SF
Light Gun Shed	215-20		___ # of bays x 788 SF/bay =	___	SF
Organic Equipment Storage Shed	441-12			Variable	SF

**Table 17115-9 Space Criteria for Marine Corps Reserve Centers (continued)
Special Requirement Space Allowance**

SPECIAL REQUIREMENTS –				
Special requirements are not included in all reserve centers, and are justified by a unit's particular mission.				
PART II (GROSS SQUARE YARDS)				
Each function must be approved by Headquarters, USMC and Commander, Marine Forces Reserve. Although these functions are located with the reserve center, for costing & scoping purposes they are not included in the 171-15 Category Code. Use appropriate Category Code unit cost. See "Derivation of Special Requirement Space Allowances for Table 17115-9" for space requirement derivation data.				
Function	Cat. Code	Calculation	Scope	UOM
Antennae Array	132-55		4,400	SY
Bulk Fuel Equipment Storage Shed	441-35		35	SY
Loading Ramp	851-15		35	SY
Vehicle Wash Platform	214-55	___ # of wash points x 90 SY/wash point =	___	SY
Tactical Vehicle Parking (Wheeled)	852-35	___ # of wheeled vehicles x 50 SY/vehicle =	___	SY
Tactical Vehicle Parking (Tracked)	852-35	___ # of tracked vehicles x 75 SY/vehicle =	___	SY
Private Owned Vehicle Parking	852-10	___ # of personnel x 35 SY/vehicle (provide a min. of 80%) =	___	SY
Quadcon Storage Pad	852-35	___ # of QUADCONS x 23 SY/QUADCON =	___	SY
HAZMAT Storage Pad	852-35	___ # of HAZMAT sheds x 23 SY/HAZMAT shed =	___	SY
MALS Van Pad	852-35	___ # of MALS vans x 34 SY/MALS van =	___	SY
Generator Storage Shed	441-35	___ # of generators x 5 SY/generator =	___	SY
Security Fencing	872-10		Variable	LF
Security fencing should be located, at a minimum, around the perimeter of the VMF, Tactical Vehicle Parking, Quad-Con Storage Lot, and Antennae Array, where applicable.				
Land	911-		10	AC

Table 17115-9(a) Derivation of Special Requirement Space Allowances for Table 17115-9

PART I		
Special requirements are not included in all reserve centers, and are justified by a unit's particular mission. Each function must be approved by Headquarters, USMC and Commander, Marine Forces Reserve.		
Function	Cat. Code	
Indoor Pistol Range	171-50	Fixed size (900 SF). For MP units only.
Rappelling Tower	179-50	Fixed size (400 SF)
Tank, Combat Training Pool	179-55	Fixed size (4,200 SF)
Parachute and Survival Equipment Shop	211-75	Fixed size (3,670 SF)
Optics Shop	213-50	Fixed size (500 SF). For units with special optical weapon system storage/maintenance requirements.
Carpenter Shop	213-56	Fixed size (800 SF)
Boat Shop	213-58	Fixed size (2,400 SF)
Scuba Locker	213-68	Fixed size (250 SF)
Vehicle Holding Shed	214-40	Variable size (1 bay at 800 gross SF for each 30 vehicles).
Light Gun Shed	215-20	Variable size (788 SF per bay). Multiply by number of bays required.
Field Maintenance Shop (Communications/Electronics)	217-30	Fixed size (3,700 SF). A separate structure with 200 SF of office space, 1,000 SF work area with tech benches, a head and vehicle access with roll-up door.
Instrument Calibration Shop	218-45	Fixed size (3,600 SF)
Organic Equipment Storage Facility	441-12	Based on 80% of unit's unique organic training allowance
Boat Storage Shed	441-35	Fixed size (1,700 SF)

Table 17115-9(a) Derivation of Special Requirement Space Allowances for Table 17115-9 (cont'd)

PART II		
Special requirements are not included in all reserve centers, and are justified by a unit's particular mission. Each function must be approved by Headquarters, USMC and Commander, Marine Forces Reserve.		
Function	Cat. Code	
Antennae Array	132-55	Fixed size (4,400 SY)
Vehicle Wash Platform	214-55	Variable size (800 SF per vehicle). Multiply by number vehicles washrack designed to accommodate.
Bulk Fuel Equipment Storage Shed	143-77	Fixed size (35 SY)
Quad Con Storage Lot	852-35	Variable size (23 SY per container)
HAZMAT Storage Pad	852-35	Variable size (23 SY per HAZMAT storage shed)
MALS Van Pad	852-35	Variable size (34 SY per van)
Generator Storage Shed	441-35	Variable size (5 SY per generator)
Loading Ramp	851-15	Fixed size (35 SY)
Tactical Vehicle Parking (Wheeled)	852-35	Variable size (50 SY per wheeled vehicle)
Tactical Vehicle Parking (Tracked)	852-35	Variable size (75 SY per tracked vehicle)
Private Owned Vehicle Parking	852-10	Variable size (35 SY per POV). Provide a minimum of parking for 80% of the drill strength
Security Fencing	872-10	Variable size around perimeter. Fencing required around VMF/tactical parking, Quad Con storage lot and antennae array, where applicable.
Land	911-	Minimum size (10 acres of useable land)

171 17 TV CENTER FOR INSTRUCTIONAL MATTER (SF)**FAC: 1441****BFR Required: Y**

17117-1 **DEFINITION.** This facility may be provided only when specifically authorized by Naval Education and Training Command (NETC). Requirements will be determined for each individual case, with NETC guidance.

171 20 APPLIED INSTRUCTION BUILDING (SF)**FAC: 1712****BFR Required: Y**

17120-1 **DEFINITION.** This facility provides for training personnel through the applied use of technical equipment and tools. Some of the characteristic features of applied instruction classrooms are:

- The use of drafting tables
- The use of workbenches to train personnel in trade/specialized skills such as electronics, machine tool operation, welding and similar.
- The use of operational training machinery such as automotive or other engines, refrigeration equipment, etc.
- The requirement for complete functional systems such as weapons delivery systems, fire control systems, etc.
- For planning purposes, applied instruction facilities can be divided into two general categories:
 - a. **General Applied Instruction Facilities** (for example, Service School Shops and Laboratories).
 - b. **Specialized Applied Instruction Facilities** (for example, Multiengine Patrol Plane Training Building).

17120-2 **PLANNING METHODOLOGY.** Facilities for each category must be planned separately because planning methodologies are different for each group. General applied instruction facilities have flexible space allowances and must be planned to individually suit the type of instruction to be accommodated. Specialized applied instruction facilities have fixed space allowances. In the following text, each category is discussed separately.

17120-3 BROAD PLANNING FACTORS

17120-3.1 **General Applied Instruction Facilities.** The gross SF building area (for BFR purposes) may be computed by either one of the two alternate methods:

- In the absence of detailed data or when close approximation to precise requirements is not considered necessary, the gross building area should be computed based on 150 gross square feet per student station.
- If specific personnel data is available follow the planning procedure and table given under Basic Category 171 and 171-20.

Figure 17120-1 provides a method to calculate floor area requirements for hands-on mockup training devices.

Figure 17120-1
Planning Formula for Determining Floor Requirements for
Hands-on Mockup Space

FORMULA: $A = B (CD + E)$

DEFINITIONS

A = Area of classroom in net SF

B = Number of items of practice equipment required. This figure is obtained by dividing C into the average number of students in each class session.

C = Number of students assigned to each item of practice equipment.

D = Net SF of floor area required for one student working on an item of practice equipment.

E = Net SF of floor area occupied by one item of practice equipment. Includes clearances and aisles. Human engineering factors, including safety, must be considered. In cases where student working areas (item D) partially overlap equipment clearance areas, insure that the space requirements are not duplicated.

17120-3.2 **SPECIALIZED APPLIED INSTRUCTION FACILITIES.** This category includes facilities designed for training in specialized functions requiring a dedicated building. Space allowances are either fixed or given in gross SF per student and in every case includes all necessary support spaces, such as administration, lounges, training aid storage, library space, reproduction areas, learning centers, toilets, showers, locker rooms,

corridors, and janitorial space. For some of the facilities listed below which require a specific building configuration, definitive designs have been prepared. Those cases are annotated in the text.

- **Flight Training and Briefing Building.** This building provides space for student pilots in support of direct flight training. Included in the allowance is space for lecture rooms and classrooms, instructor pilot offices, ready rooms, flight planning rooms, briefing rooms, and other support space. The facility provides the necessary space for interaction of student and instructor in briefing and debriefing of actual training flight, singly or in groups. This space is over and above the space requirements for extensive classroom, instrument trainer or flight simulator training, which are covered in other category codes or in other sublistings under this category code. Also, this space is in addition to the normal squadron administrative space covered under category code 211 07. The planning factor for Flight Training and Briefing Building is 125 gross SF Per student, based on the average on-board student load.
- **Naval Air Maintenance Training Building.** Naval Air Maintenance Training Buildings provide the necessary classrooms and other space in support of one or more Maintenance Trainer Sets (MTS's). MTS's, consisting of instructional items as displays, actual systems/subsystems/equipment/parts/materials, cut-aways, mock-ups, audio/visual aids, provide maintenance personnel and pilots with technical training on aeronautical systems and associated equipment, organizational and intermediate maintenance, operation and special techniques as applied to aircraft subsystems, missiles and specific equipment and other training as the Chief of Naval Operations may direct.

17120-3.3 The planning factor for the Naval Air Maintenance Training Building is 160 gross SF per student. The number of students for planning purposes shall be the average on-board student loading.

17120-3.4 Highly sophisticated new weapon systems may require more space than would be computed on the basis of 160 square feet per student. The facility or site study prepared for each new weapon system provides the necessary information for making such determination. When the maintenance training space requirement is found to exceed 160 square feet per student, the requirements shall be fully documented, to include data relative to size of trainers, students per trainer, support space requirements and other pertinent matters to enable evaluation of the actually required gross area.

- **Fleet Readiness Aviation Maintenance Personnel (FRAMP) and Aircrew Learning Center.** This facility provides classrooms, briefing rooms and environmentally protected FRAMP practical training work areas to

support initial and recurrent training for fleet aircrew (pilots, Naval Flight Officers, and when applicable, enlisted crew members) and aircraft maintenance personnel. Gross area requirements vary with model of aircraft and student loading and must be determined for each individual case. Although FRAMP and aircrew training facilities can be separate, integrated facilities permit efficient utilization of classrooms, study carrels, media reproduction and support areas and administrative spaces. Simulator facilities (code 171 35) may be attached to this building.

- **All Weather Training Building.** The all-weather training building provides the necessary space to house the special devices used by pilots, crewmen, and ground controllers to maintain their operating proficiency for adverse weather conditions. The planning factor for this facility is one (1) standard all-weather training building for an all-weather training station supporting two or more all-weather squadrons. The standard all-weather training building has an area of 7702 gross SF. The building contains six classrooms of about 600 square feet each to house special devices, a map-making room, support spaces and space for routine maintenance and equipment testing.
- **Multi-engine Patrol Plane (VP) Training Building.** This facility houses special devices and gear used by patrol pilots and crewmen to maintain proficiency in submarine search and detection, aircraft and missile detection, and the employment of counter-measures against enemy radar. The planning factor is one (1) standard multi-engine patrol plane training building for a patrol plane station with a mission for continuous support of two or more patrol squadrons. The facility has an area of 26,120 gross SF, and contains 23 classrooms (18 feet by 22 feet average size), support spaces, and a lecture-demonstration hall.
- **Aviation Physiological Training Building.** This building provides classroom and support space for implementation of the aviation physiology training syllabus. The syllabus pertains to aeromedical aspects of night vision, acceleration and deceleration forces, explosive decompression, oxygen equipment, pressure suits, survival, protective and safety equipment. The planning factor is one (1) aviation physiological training building for each station that will support four carrier air groups or the equivalent of one HATWING OF VAH jet aircraft. The building is planned with the concurrence of NAVMEDCOM. The size of the building is 15,000 gross SF.
- **Delivery Retaining Detachment Building.** This facility provides refresher training for teams that handle and maintain special weapons and for pilots and crews assigned special weapons missions. The planning

factor is one (1) delivery retraining detachment building for each air station supporting operational units with a special weapons capability. The building has an area of 1,590 gross SF.

- **Naval Construction Battalion Unit (CBU) Facility.** This facility provides a construction unit contingency augmentation capability to the Naval Construction Forces and assures unit and individual skill training essential to required readiness posture. Space requirements may be satisfied by a single or multiple building configuration. Facilities of this type will be planned only at locations designated by higher authority. Space allowances for CBU's are given in Table 17120-1
- **Band Practice Facility.** Table 17120-2 provides a summary list of the recommended areas for each of the spaces for both small and large bands. Local differences in operational patterns and function programs may require some modifications to the space program. These differences may, for example, include; larger or smaller size for individual spaces; different relationship patterns between spaces; or elimination or addition of specific spaces.
- **Combat Training Pool/Tank, Enclosed.** This facility provides an enclosed pool/tank for instruction in swimming and survival under combat conditions. It includes the pool and supporting spaces, such as locker room, instructional deck, mechanical room, etc., however the actual composition of individual facilities may vary according to their particular training requirements. Unique pool/tank design considerations may be required for specialized training facilities such as aviators' survival training tanks and EOD/underwater demolition training. For general planning criteria, See Category Code 179 55.

**Table 17120-1
Space Criteria for Naval Construction Battalion Units**

Functional space	Notes	Gross Sq Ft	Gross Sq M
Administration		1,460	136
Engineering Lab		570	53
Locker/Showers	(3)	1,000	93
Classroom/Workbench		1,060	98
Classroom/Academic		580	54

Equipment Maintenance Shops	(1)	4,400	409
Vertical Shops (BU/SW/CE/UT)	(2)	4,000	372
Central Tool Room (CTR)	(2)	2,940	273
Project Material Storage (MLO)	(2)	2,540	236
Greens Issue/782 Issue	(2)	810	75
TOTAL GROSS AREA		19,360	1,799

Notes:

- (1) Based on three equipment repair bays.
- (2) Definition for the abbreviations used in this criterion are as follows:

BU = Builder
 SW = Steelworker
 CE = Construction Electrician
 UT = Utilitiesman
 CTR = Central Tool Room
 MLO = Construction Project Material Storage (operated by the Materials Liaison Officer)
 Greens/782 Issue = Organizational Clothing/Gear Issue

- (3) Total Gross Area includes both men and women.

**Table 17120-2
Recommended Space Allocations for Navy Band Training Facilities**

Function-Space	Small Fleet Band (35 pieces)		Large Fleet Band (45 pieces) Or Large Fleet Band-Plus (60 pieces)	
	Approx. no. of spaces	Square Meters	Approx. no. of spaces	Square Meters
Main Rehearsal Room	1	146	1	211
Practice Rooms-Group				
Large Group	1	65	1	65
Small Group	1	28	2	30
Practice Rooms-Individual				
Large Individual	2-4	7-12 ea.	3-6	7-12 ea.
Small Individual	6-8	5-6 ea.	9-12	5-6 ea.
Subtotal	8-10	77	12-15	106
Recording/Audio Control Booth	1	23	1	23
Library	1	46	1	59
Offices (No. of persons)	9	109	13	157
Personal Support				
Individual Instructor Lockers	1	48	1	63
Instrument Cleaning	1	7	1	7
Day Area	1	59	1	80
Toilets/Lockers/Showers				
Men		82		112
Women		42		45
Officer's Toilet				

Function-Space	Small Fleet Band (35 pieces)		Large Fleet Band (45 pieces) Or Large Fleet Band-Plus (60 pieces)	
	Approx. no. of spaces	Square Meters	Approx. no. of spaces	Square Meters
Storage and Supply				
Unit Supply/Storage	1	93	1	121
Instrument Repair	1	9	1	9
Janitor's Closet	1	5	1	5
Transition				
Lobby	1	56	1	84
Circulation				
Subtotal Indoor Space-Net Only		895		1182
Circulation, Walls, etc. @25%		224		296
Subtotal		1119		1478
Mechanical Spaces @ 5%		56		74
GROSS TOTAL (Rounded)		1171		1552
Outdoor Spaces				
Drill Area	See CCN 179-60		See CCN 179-60	
Parking Area (1 space per band piece)	See CCN 852-10		See CCN 852-10	

171 21 DECONTAMINATION TRAINING FACILITY (DELETED)

FAC: 1712

BFR Required: Y

17121-1 This category code is deleted. Decontamination training areas are integral to the operational facilities they occupy and as such, are not a standalone facility.

171 25 GENERAL PURPOSE AUDITORIUM (SF)

FAC: 7431

BFR Required: Y

17125-1 **DEFINITION.** An auditorium may be authorized when required as an adjunct to training or other functions (except administration). The primary purpose of the auditorium is an assembly area for instruction and training. General purpose auditoriums will not be planned at an installation where a motion picture theater is authorized except where justified by special circumstances. Seating capacity of an auditorium is to be determined in each specific case and justification provided. The size of an auditorium shall be calculated based on 12 square feet per seat gross floor area or 9 square feet per seat net floor area (in cases where auditorium is a part of a multiple use building sharing common circulation and service spaces).

171 30 PHYSICAL EDUCATION FACILITY (SF)

FAC: 1715

BFR Required: Y

17130-1 **DEFINITION.** A building that houses physical education training facilities at the United States Naval Academy (USNA) at Annapolis, Maryland. These facilities are used for the fitness development program of instruction at the USNA. This CCN is for use only by the USNA.

17130-2 **GENERAL.** An engineering analysis is required to determine facility space allocations.

171 35 OPERATIONAL TRAINER FACILITY (SF)**FAC: 1721****BFR Required: Y**

17135-1 **DEFINITION.** This category is assigned to training space which meets one or more of the following criteria:

17135-1.1 It houses large operational trainers, usually duplicating part or all of surface or air weapons system.

17135-1.2 It is specifically designed and sized for a trainer; has characteristics such as high ceiling height, large room dimensions, and removable exterior wall panels to facilitate servicing; it may also include special design features to satisfy stability requirements of visual systems, unique environmental control requirements (HVAC & filtering), loads associated with motion base(s), and abnormal power requirements.

17135-1.3 Actual space requirement is dictated by the size of the trainer rather than student loading.

Examples of the type of trainers which should be categorized under this code area:

- a. Weapons System Trainer/Flight Simulator.*
- b. Part-Task Trainer (air).*
- c. Cockpit Procedure Trainer.*
- d. Instrument Trainer.*
- f. Full scale models of ships boiler rooms.*
- g. Full scale mock-up of a Trident tube.*
- h. Full scale mock-up of a Tomahawk Launcher.*
- i. Large scale models of water basins for practice of berthing procedures.*
- e. Mock-ups of ships and submarines and their associated armament.*

17135-2 Space which houses small trainers, such as radios, etc., is not categorized under this code, even though the trainers are operational. Use Category Code 171 20.

As space for operational trainers may occur as either a separate facility or as a wing or room of an applied instruction building, the following method of assigning the appropriate category code shall be used.

17135-3 In the case of a building to be used solely for the housing of a trainer and its required support space, the entire building shall be categorized as Category Code 171 35. The support space includes corridors, storage, briefing rooms, offices, mechanical room, and the like.

17135-4 If an operational trainer is included as part of a larger instruction building, the room housing the trainer shall be categorized as Category Code 171 35. This Category Code also includes support spaces for the trainer, including storage, briefing room equipment, and repair room. If any of the support spaces are used jointly for the operation of the trainer and the instruction given in the rest of the building, the support space shall be given the category assigned to the building, usually Category Code 171 20.

17135-5 Planning factors are given for a limited number of operational trainer facilities. Others will be added as they are developed. Where planning factors are not available, space requirements must be fully justified by and Engineering Evaluation. Room sizes, size of trainers, and support space should be listed, and the justification should be accompanied by drawings.

17135-6 Flight Simulator Space. This facility houses the Flight Simulator/Weapon System Trainer (WST) and associated Part Task Trainers (PTT). It is planned for stations supporting naval aircraft and is sized depending on aircraft type and average number of squadrons on-board. The total number of organizational units permanently assigned plus the average number of organizational units of rotational and special aircraft on-board shall be used for planning. Table 171-35A provides information on the gross areas required. The 6,000-square-foot area for example, will contain the following basic components:

- Trainer Room. An air-conditioned room of 50 by 50 feet minimum size, to house the necessary equipment of one (1) Weapon System Trainer (WST).
- Briefing Room. A classroom to house a maximum class of 20 pilots at 20 square feet per man.
- Administration. Office space for the officer-in-charge and two assistants.
- Maintenance Shop. A 20- by 15-foot space for the periodic maintenance of the test equipment.

- Mechanical and Electrical Equipment Room. Space of about 15 by 20 feet for the heating, air conditioning, and electrical distribution panels.
- Part Task Trainer Rooms. A minimum of two rooms of 20 by 20 feet for the housing of two Part Task Trainers (PTT).
- The other sizes will have similar requirements.

**Table 17135-1
Flight Simulator Trainer Space Requirements**

Type of Squadron	Number of Squadrons	Number of Trainers	Gross Area (Sq Ft)
VA/VF/HS/HM	2 - 8	1-WST, 2-PTT	6,000
	9 - 15	2-WST, 2-PTT	7,500
VA/VP	1 - 4 (VS)	1-WST, 2-PTT	9,000
	1 - 2 (VP)		
VS/VP	5 - 8 (VS)	2-WST, 4-PTT	12,000
	3 - 5 (VP)		

17135-7 **Instrument Trainer Space.** This facility houses instrument trainers and cockpit procedure trainers. The size of this facility is based upon the number and type of aircraft squadrons or attack carrier air wings (CVW). Table 17135-2 provides information on the gross area requirements. Included is space for: administrative office, briefing room, technical order library, storage room, equipment maintenance shop, mechanical equipment room, and trainer room. In using Table 17135-2, the total number of permanently assigned organizational units on-board shall be counted.

**Table 17135-2
Basic Instrument Trainer Space Requirements**

Type of Unit	Number of Units	Gross Area (Sq Ft)
VP, VS, or AEW squadron	1 squadron	5,000
	2 squadrons	8,000
CVW of VF/VA/HS/HM	1 or 2 wings	5,000
	3 or 4 wings	8,000

171 36 RADAR SIMULATOR FACILITY (SF)

FAC: 1724

BFR Required: Y

17136-1 AUTHORIZATION. This facility may be provided only when specifically authorized by Naval Education and Training Command (NETC). Requirements will be determined for each individual case, with NETC guidance.

171 40 DRILL HALL (SF)

FAC: 1714

BFR Required: Y

17140-1 JUSTIFICATION. Need for this facility must be determined on an individual basis and requires specific justification; this code is generally intended for inventory purposes.

171 45 MOCK-UP AND TRAINING AID PREPARATION CENTER (SF)**FAC: 1732****BFR Required: Y**

17145-1 **AUTHORIZATION.** This facility may be provided only when specifically authorized by Naval Education and Training Command (NETC). Requirements will be determined for each individual case, with NETC guidance.

171 50 SMALL ARMS RANGE - INDOORS (SF)**FAC: 1718****BFR Required: Y**

17150-1 **DEFINITION.** An indoor small arms range provides training space for the use of pistols and small caliber (22) rifles. Ranges will be used by all services on a joint basis when feasible, and they must be of sufficient size and capacity to provide continual training and retraining for all military personnel that require weapons training/qualification.

17150-2 The capacity of existing ranges or new requirements can be determined by:

1. Identifying the number of personnel to be trained.
2. Establish the number and size of training sessions.
3. Determine the number of hours per session and schedule training over an annual basis.
4. Calculate the required number of firing points based upon efficient arrangement of the size and schedules of the training groups.

17150-3 Indoor ranges are generally planned at locations where prevailing weather conditions seriously interfere with the scheduling of training. Otherwise, plan for outdoor ranges (Category Code 179 40).

For indoor range design criteria, refer to UFC 4-179-02.

171 60 RECRUIT PROCESSING BUILDING (SF)**FAC: 6100****BFR Required: Y**

17160-1 **DEFINITION.** A recruit processing building is a facility for receiving, examining, and outfitting recruits. The processing building must provide space for the complete orientation, examination, and processing (medical, dental, supply, administrative) of all newly inducted and recruited personnel. The size of the facility will be determined by an engineering survey.

171 77 TRAINING MATERIAL STORAGE (READY ISSUE / SHOP STORES / MISC) (SF)**FAC: 1732****BFR Required: Y**

17177-1 **DEFINITION.** Storage facilities for miscellaneous goods or equipment related to training facility support will be provided only where it can be individually justified. There are no criteria for this type of facility. General information on storage parameters is provided in Category Code series 440.

172 30 GAS CHAMBER (SF)**FAC: 1723****BFR Required: Y**

17230-1 **DEFINITION.** A gas chamber is a building used for training personnel in the use of protective masks and the effects of chemical warfare.

173 10 RANGE OPERATIONS BUILDING (SF)**FAC: 1731****BFR Required: Y**

17310-1 **DEFINITION.** Range Operations Buildings are designed for direct support to range operations. Such buildings can support a variety of operations for a firing range, such as: range operations, administrative support, target

storage and issue, equipment storage and maintenance, and ammunition breakdown and distribution (not storage). This category includes buildings associated with range operations such as range operations centers, operations/storage buildings, and ammo breakdown buildings (not ammunition storage). This Category Code is for buildings only; report structures used for these purposes as Category Code 173 30, Covered Training Area.

173 11 RANGE SUPPORT BUILDING (SF)

FAC: 1731

BFR Required: Y

17311-1 **DEFINITION.** A Range Support Building would be a building which houses support functions conducted at the range complex, but not covered elsewhere. This includes range billets, classroom space at a range, buildings to conduct after action reviews, and all other range support activities with the exception of activities described in Range Operations Building (Category Code 173 10), Weapons Range Observation Tower (Category Code 179 35), and Public Toilet (Category Code 730 75). This Category Code is for buildings only; structures used for this purpose should be reported as Category Code 17330, Covered Training Area.

173 20 TRAINING AIDS CENTER (SF)

FAC: 1732

BFR Required: Y

17320-1 **DEFINITION.** A Training Aids Center is a building that is used to fabricate, maintain, store, and issue training devices and materials including Multiple Integrated Laser Equipment System (MILES) and visual information (VI) aids; it also provides the administrative space for the training support division (TSD) management staff.

173 30 COVERED TRAINING AREA (SF)

FAC: 1733

BFR Required: Y

17330-1 **DEFINITION.** Covered Training Areas are structures which provide a covered area to support and conduct training or for feeding of personnel on a training facility while providing protection for equipment and personnel from the

elements. Typically, the sides of the structure are open with a solid roof. This category also includes structures that support range operations. These facilities are usually located in ranges, training areas, bivouac, or maneuver areas. Square footage is measured as the area under the room or cover. Also this Category Code is used to report covered physical training areas and covered martial arts training areas.

173-40 OBSERVATION TOWER/BUNKER (SF)

FAC: 1783

BFR Required: Y

17412-1 **DEFINITION.** An Observation Tower/Bunker is a protective shelter used at Navy/Marine Corps EOD ranges for the protection of EOD technicians and observers. Location of the Tower/Bunker must be IAW NAVSEA OP-5. An Engineering Evaluation must be conducted to determine the correct size of the facility.

174 10 MANEUVER/TRAINING AREA, LIGHT FORCES (AC)

FAC: 1741

BFR Required: N

17410-1 **DEFINITION.** This category includes all space for ground and air combat forces to practice movements and tactics. Different types of units may support one another (combined arms), or a unit may operate independently. The "light" designation refers to areas where maneuver is restricted to only small units or units having only wheeled vehicles. "Light" maneuver/training areas are not typically used by "heavy" or mechanized forces, other than in assembly areas where movement is restricted to roads or trails. Included in this category are bivouac sites, base camps, and other miscellaneous training areas. Account for each area, typically managed and scheduled by a range name or code through the installation training or range control manager with a separate facility number and individual real property record. When maneuver/training areas can be used for multiple purposes, priority of assignment is Maneuver/Training Area, Amphibious; Maneuver/Training Area, Heavy; Maneuver/Training Area, Light.

174 11 MANEUVER/TRAINING AREA, AMPHIBIOUS FORCES (AC)**FAC: 1741****BFR Required: N**

17411-1 **DEFINITION.** This category includes all space for ground and air combat forces to practice movements and tactics during amphibious (ship-to-shore) operations. Different types of units may work in support of one another (combined arms), or the units may operate independently. Tasks can include both combat and logistics (especially logistics over the shore (LOTS)). This category also includes areas with bivouac sites, base camps, and other miscellaneous training areas. Account for each area, typically managed and scheduled by a range name or code through the installation training or range control manager, with a separate facility number and individual real property record. When maneuver/training areas can be used for multiple purposes, priority of assignment is Maneuver/Training Area, Amphibious; Maneuver/Training Area, Heavy; Maneuver/Training Area, Light.

174 12 LAND NAVIGATION COURSE (AC)**FAC: 1741****BFR Required: N**

17412-1 **DEFINITION.** A Land Navigation Course is an area located within the training complex which is principally scheduled and used for map reading, terrain association, or navigational training.

174 13 FIELD TRAINING AREA (AC)**FAC: 1741****BFR Required: N**

17413-1 **DEFINITION.** A Field Training Area is a specific area that is intended for the training of personnel or animals in a field environment that cannot be categorized by the other Category Codes in the 174 basic series. Training conducted in such an area may include medical, K-9, or communications equipment. Maneuver land shall not be included in this category; separately classify maneuver in other Category Codes within the 173 basic series.

174 20 MANEUVER/TRAINING AREA, HEAVY FORCES (AC)**FAC: 1742****BFR Required: N**

17420-1 **DEFINITION.** This category includes all space for ground and air combat forces to practice movements and tactics. Different types of units may support one another (combined arms), or may operate independently. The “heavy” designation refers to areas where maneuver is unrestricted and can consist of all types of vehicles and equipment, including tracked vehicles. “Heavy” maneuver/training areas can be used by “light” forces. This category includes bivouac sites, base camps, and other miscellaneous training areas. This area is typically managed and scheduled by a range name or code through the installation training or range control manager, and is accounted for with a separate facility number and individual real property record. When maneuver/training areas can be used for multiple purposes, priority of assignment is Maneuver/Training Area, Amphibious; Maneuver/Training Area, Heavy; Maneuver/Training Area, Light.

174 30 IMPACT AREA DUDDDED (AC)**FAC: 1743****BFR Required: N**

17430-1 **DEFINITION.** An area having designated boundaries within which all ordnance will detonate or impact shall be categorized as Impact Area Duddded. This area includes all impact areas that do not contain automated targets or targets classified as real property. Vehicle bodies are sometimes placed in the area to act as targets for artillery direct and indirect fire. The primary function of the impact area is to contain weapons effects as much as possible using earthen berms or natural terrain features. Assume the impact areas contain unexploded ordnance and may not be used for maneuver. This area is typically managed and scheduled by a range name or code through the installation training or range control manager, and is accounted for with a separate facility number and individual real property record.

174 31 IMPACT AREA NON-DUDDER (AC)**FAC: 1743****BFR Required: N**

17431-1 **DEFINITION.** An area having designated boundaries within which ordnance that does not produce duds will impact is an Impact Area Non-Dudded. This area is composed mostly of the safety fans for small arms ranges. This area includes all impact areas that do not contain automated targets or targets classified as real property. The primary function of the impact area is to contain weapons effects as much as possible using earthen berms or natural terrain features. A separate facility number and individual real property record shall be issued to account for each area that should be managed and scheduled by a range name or code through the installation training or range control manager. Although these impact areas may be used for maneuver, when the weapons ranges are not in use, they will remain categorized as impact areas.

174 40 PERSONNEL/EQUIPMENT DROP ZONE (AC)**FAC: 1744****BFR Required: N**

17440-1 **DEFINITION.** A large, flat, cleared area for personnel and equipment to land following a parachute jump shall be categorized as a Personnel/Equipment Drop Zone.

175 01 AUTOMATIC RIFLE RANGE (AC)**FAC: 1750****BFR Required: Y**

17501-1 **DEFINITION.** The Automatic Rifle Range is designed for training target engagement techniques with rifles and squad automatic weapon (SAW). This range is used to train personnel on the skills necessary to employ automatic and semi-automatic firing techniques. Within this range targets are not fully automated and the scenarios are not computer driven or scored. This Category Code will not be used for ranges where the principal use is defined in other Category Codes within the 175 series.

175 02 NON-STANDARD SMALL ARMS RANGE (AC)**FAC: 1750****BFR Required: Y**

17502-1 **DEFINITION.** The Non-Standard Small Arms Range is designed for training requirements that are not associated with current published doctrine, but fall within a commander's training requirements. This range includes all small arms ranges that do not fit into other categories. Targets in this range are not fully automated and/or the scenarios are not computer driven or scored. This Category Code number includes dedicated dry fire areas.

175 10 BASIC 10M-25M FIRING RANGE (ZERO) (AC)**FAC: 1751****BFR Required: Y**

17510-1 **DEFINITION.** A Basic Zero Firing Range is designed for training shot-grouping and zeroing exercises with rifles and machine guns. This range is used to train individual personnel on the skills necessary to align the sights and practice basic marksmanship techniques against stationary targets. This range requires no automation.

175 20 AUTOMATED FIELD FIRE (AFF) RANGE (AC)**FAC: 1752****BFR Required: Y**

17520-1 **DEFINITION.** An Automate Field Fire Range is designed for training target engagement techniques with rifles. This range is used to train and familiarize personnel on the skills necessary to identify, engage, and hit stationary infantry targets. All targets are fully automated and in the event specific target scenario is computer driven and scored from the range operations center.

175 30 RECORD FIRE RANGE, NON-AUTOMATED (AC)**FAC: 1753****BFR Required: Y**

17530-1 **DEFINITION.** A Record Fire Range is designed for training and day/night qualification requirements with rifles. This range is used to train and test personnel on the skills necessary to identify, engage, and hit stationary infantry targets. Targets are not fully automated and/or the scenarios are not computer driven or scored. This Category Code will not be used for Known-Distance (KD) Ranges, which are accounted for under Category Codes 175 50 and 175 70.

175 31 AUTOMATED RECORD FIRE (ARF) RANGE (AC)**FAC: 1753****BFR Required: Y**

17531-1 **DEFINITION.** An Automated Record Fire Range is designed for training and day/night qualification requirements with rifles. This range is used to train and test personnel on the skills necessary to identify, engage, and hit stationary infantry targets. All targets are fully automated and the event specific target scenario is computer driven and scored from the range operations center. This category code number will not be used for Known-Distance (KD) Ranges, which are accounted for under Category Codes 175 50 and 175 70.

175 32 MODIFIED RECORD FIRE RANGE (AC)**FAC: 1753****BFR Required: Y**

17532-1 **DEFINITION.** A Modified Record Fire Range is designed for training and day/night qualification with rifles. This range combines the capabilities of 1752X, Automated Field Fire (AFF) Range; and 1753, Automated Record Fire (ARF) Range to reduce land and maintenance requirements. All targets are fully automated and the event specific target scenario is computer driven and scored from the range operations center. This Category Code Number will not be used for Known-Distance (KD) Ranges, which are accounted for under Category Codes 175 50 and 175 70.

175 50 RIFLE KNOWN DISTANCE (KD) RANGE (AC)**FAC: 1755****BFR Required: Y**

17550-1 **DEFINITION.** A Rifle Known Distance Range is designed for training rifle marksmanship and target engagement techniques. This range is used to train personnel on the skills necessary to identify, engage, and hit stationary targets in a static array from a known distance.

175 60 SNIPER FIELD FIRE RANGE (AC)**FAC: 1756****BFR Required: Y**

17560-1 **DEFINITION.** A Sniper Field Fire Range is designed to meet training and qualification requirements with the sniper rifle. This range is used to train and test snipers on the skills necessary to detect, identify, engage, and hit stationary and moving infantry targets in a tactical array in accordance with applicable field manuals. In this range targets are not fully automated and/or the scenarios are not computer driven or scored.

175 61 AUTOMATED SNIPER FIELD FIRE RANGE (AC)**FAC: 1756****BFR Required: Y**

17561-1 **DEFINITION.** An Automated Sniper Field Fire Range is designed to meet the training and qualification requirements with the sniper rifle. This range is used to train and test snipers on the skills necessary to detect, identify, engage, and hit stationary and moving infantry targets in a tactical array in accordance with applicable field manuals. All targets are fully automated and the event specific target scenario is computer driven and scored from the range operations center.

175 70 PISTOL KNOWN DISTANCE (KD) RANGE (AC)**FAC: 1757****BFR Required: Y**

17570-1 **DEFINITION.** A Pistol Known Distance (KD) Range is designed for training pistol and revolver marksmanship and target engagement techniques. This range is used to train personnel on the skills necessary to identify, engage, and hit stationary targets in a static array from a known distance.

175 71 COMBAT PISTOL/MP FIREARMS QUALIFICATION COURSE (AC)**FAC: 1757****BFR Required: Y**

17571-1 **DEFINITION.** A Combat Pistol/MP Firearms Qualification Course is a range designed to meet training and qualification requirements with combat pistols and revolvers. This range is used to train and test personnel on the skills necessary to identify, engage, and hit stationary infantry targets. In this range targets are not fully automated and/or the scenarios are not computer driven or scored.

175 72 AUTOMATED COMBAT PISTOL/MP FIREARMS QUALIFICATION COURSE (AC)**FAC: 1757****BFR Required: Y**

17572-1 **DEFINITION.** An Automated Combat Pistol/MP Firearms Qualification Course is a range designed to meet training and qualification requirements with combat pistols and revolvers. This range is used to train and test personnel on the skills necessary to identify, engage, and hit stationary infantry targets. All CPQC targets are fully automated and the event specific target scenario is computer driven and scored from the range operations center.

175 73 SUBMACHINE GUN RANGE (AC)**FAC: 1757****BFR Required: Y**

17573-1 **DEFINITION.** A Submachine Gun Range is designed for training target engagement techniques with the submachine gun. This range is used to train personnel on the skills necessary to identify, engage, and hit stationary infantry targets. Targets are not fully automated and/or the scenarios are not computer driven or scored within this range.

175 80 MACHINE GUN TRANSITION RANGE (AC)**FAC: 1758****BFR Required: Y**

17580-1 **DEFINITION.** A Machine Gun Transition Range is designed to meet the training requirements with machine guns. This range is used to train personnel on the skills necessary to identify, engage, and hit stationary infantry targets at known distances. Targets within this range are not fully automated and/or the scenarios are not computer driven or scored. Ranges that fulfill purpose of both Machine Gun Transition Range (Category Code 175 80) and Machine Gun Field Fire Range (Category Code 175 81) will be carried as Machine Gun Field Fire Range (Category Code 175 81).

175 81 MACHINE GUN FIELD FIRE RANGE (AC)**FAC: 1758****BFR Required: Y**

17581-1 **DEFINITION.** A Machine Gun Field Fire Range is designed to train target engagement techniques with squad assault weapons and machine guns. This range is used to train personnel on the skills necessary to identify, engage, and hit stationary infantry, vehicle, and bunker type targets. Distance to targets is not predetermined. Within this range targets are not fully automated and/or the scenarios are not computer driven or scored. Ranges that fulfill purpose of both Machine Gun Transition Range (Category Code 175 80) and Machine Gun Field Fire Range (Category Code 175 81) will be carried as Machine Gun Field Fire Range (Category Code 175 81).

175 82 AUTOMATED MULTIPURPOSE MACHINE GUN (MPMG) RANGE (AC)**FAC: 1758****BFR Required: Y**

17582-1 **DEFINITION.** An Automated Multipurpose Machine Gun (MPMG) Range is designed for zeroing, training, and qualification requirements with squad assault weapons (SAW) and machine guns. This range is used to train personnel on the skills necessary to identify, engage, and hit stationary infantry targets. All targets within this range are fully automated and the event specific target scenario is computer driven and scored from the range operations center.

176 10 GRENADE LAUNCHER RANGE (AC)**FAC: 1761****BFR Required: Y**

17610-1 **DEFINITION.** A Grenade Launcher Range is designed to meet training and qualification requirements of the 40mm M203 Grenade Launcher. This range is used to train and test personnel on the skills necessary to engage and defeat stationary target emplacements with the 40mm Grenade Launcher. No automation is required for this facility. Count FP as each collection of points or lanes that allow completion of all training objectives.

176 20 40MM (GRENADE) MACHINE GUN QUALIFICATION RANGE (AC)**FAC: 1762****BFR Required: Y**

17620-1 **DEFINITION.** A 40MM Machine Gun Qualification Range is designed to conduct training qualification firing with the grenade machine gun (e.g., MK-19). This range is used to train personnel with the weapon either ground or vehicle mounted. Targets in this range may be either non-automated or fully automated and the event specific target scenario is computer driven and scored from the range operations center. A lane is defined as the area for one gunner/weapon system to complete the training objectives.

176 30 LIGHT ANTIARMOR WEAPONS RANGE SUBCALIBER (AC)**FAC: 1763****BFR Required: Y**

17630-1 **DEFINITION.** A Light Anti-armor weapons range is designed for training target engagement techniques with light anti-armor weapons (e.g., LAW/AT-4). This range is used to train personnel on the skills necessary to employ the weapon and hit stationary and moving targets using a sub-caliber training device. Targets are not fully automated and/or the scenarios are not computer driven or scored. Ranges used for both live and sub caliber firing will be carried under the Light Anti-armor Weapons Range Live (Category Code 176 31).

176 31 LIGHT ANTIARMOR WEAPONS RANGE LIVE (AC)**FAC: 1763****BFR Required: Y**

17631-1 **DEFINITION.** A Light Anti-armor Weapons Range Live is designed for training target engagement techniques with light anti-armor weapons (e.g., LAW/ AT-4). This range is used to train personnel on the skills necessary to employ the weapon and hit stationary and moving targets using live rockets or a sub-caliber training device. Targets are not fully automated and/or the scenarios are not computer driven or scored. Ranges used for both live and sub-caliber firing will be carried under this Category Code.

176 40 ANTIARMOR TRACKING AND LIVE-FIRE RANGE (AC)**FAC: 1764****BFR Required: Y**

17640-1 **DEFINITION.** An Anti-armor Tracking and Live-Fire Range is a complex designed to meet training and qualification requirements with medium and heavy anti-armor weapons systems (e.g., Javelin, TOW, SMAW). This complex is used to train and test soldiers on the skills necessary to employ the weapon, identify, track, engage, and defeat stationary and moving armor targets presented individually or as part of a tactical array. In this complex targets are not fully automated and/or the scenarios are not computer driven or scored. One lane is designed to accommodate up to 10 gunners/weapons.

176 41 AUTOMATED ANTIARMOR TRACKING AND LIVE-FIRE RANGE (AC)**FAC: 1764****BFR Required: Y**

17641-1 **DEFINITION.** An Automated Anti-armor Tracking and Live-Fire Range is a complex designed to meet training and qualification requirements with medium and heavy anti-armor weapons systems (e.g., Javelin, TOW, SMAW). This complex is used to train and test personnel on the skills necessary to employ the weapon, identify, track, engage, and defeat stationary and moving armor targets presented individually or as part of a tactical array. All targets within this range are fully automated, computer driven, and scored from the range operations center. One lane is designed to accommodate up to 10 gunners/weapons.

176 50 FIELD ARTILLERY DIRECT FIRE RANGE (AC)**FAC: 1765****BFR Required: Y**

17650-1 **DEFINITION.** A Field Artillery Direct Fire Range is designed to meet training requirements of field artillery crews. This range is used to train field artillery crews on the skills necessary to employ direct fire gunnery techniques with indirect fire equipment against stationary targets in a tactical array using live direct fire artillery. No automation is required for this facility. EA is defined as the range area to support up to one battery of artillery.

176 60 TANK/FIGHTING VEHICLE STATIONARY GUNNERY RANGE (AC)**FAC: 1766****BFR Required: Y**

17660-1 **DEFINITION.** A Tank/Fighting Vehicle Stationary Gunnery Range is designed for conducting weapons system bore sighting, screening, zeroing and/or harmonization. Armor, infantry and/or aviation crew use this range. Within this range targets may be fully automated and/or scored from the range operations center. EA is defined as the range area to support up to 15 guns.

176 70 MORTAR RANGE (AC)**FAC: 1767****BFR Required: N**

17670-1 **DEFINITION.** A Mortar Range is designed to meet the training requirements of mortar crewmen. This range is used to train mortar crews on the skills necessary to apply fire mission data, engage, and hit stationary targets in a tactical array using live fire mortars. No automation is required for this facility. EA is defined as the range area to support up to the mortar section.

176 71 FIELD ARTILLERY INDIRECT FIRE RANGE (AC)**FAC: 1767****BFR Required: N**

17671-1 **DEFINITION.** A Field Artillery Indirect Fire Range is designed to meet the training and qualification requirements of field artillery units. This range is used to train field artillery crews on the skills necessary to apply fire mission data, engage, and hit stationary targets in a tactical array with indirect fire. No automation is required for this facility. EA is defined as the range area to support up to one battery of artillery.

176 80 MORTAR SCALED RANGE (AC)**FAC: 1768****BFR Required: Y**

17680-1 **DEFINITION.** A Mortar Scaled Range is designed to meet the training requirements of mortar crewmen. This range is used to train mortar crews on the skills necessary to apply fire mission data, engage, and hit stationary targets in a tactical array using sub-caliber training devices. No automation is required for this facility. EA is defined as the range area to support up to three mortars.

176 81 FIELD ARTILLERY SCALED RANGE (AC)**FAC: 1768****BFR Required: Y**

17681-1 **DEFINITION.** A Field Artillery Scaled Range is designed to meet training requirements of field artillery crews. This range is used to train field artillery crews on the skills necessary to apply fire mission data, engage, and hit stationary targets in a tactical array using sub-caliber training devices. No automation is required for this facility. EA is defined as the range area to support up to three artillery pieces.

176 90 SCALED GUNNERY RANGE (1:30 AND 1:60) (AC)**FAC: 1769****BFR Required: Y**

17690-1 **DEFINITION.** A Scaled Gunnery Range (1:30 and 1:60) is designed to meet training requirements of armor crews. This range is used to train armor crews on the skills necessary to detect, identify, engage, and hit stationary and moving scaled targets in a tactical array using sub-caliber training devices. No automation is required for this facility. No standard facilities are associated with this range. EA is defined as a range designed to handle 4 vehicles.

176 91 SCALED GUNNERY RANGE (1:5 AND 1:10)**FAC: 1769****BFR Required: Y**

17691-1 **DEFINITION.** A Scaled Gunnery Range (1:50 and 1:10) is designed to meet training requirements of armor and infantry crews. This range is used to train armor and infantry crews on the skills necessary to detect, identify, engage, and hit stationary and moving scaled targets in a tactical array using sub-caliber training devices and/or simulations. All targets are fully automated, computer driven, and scored from the range operations center. EA is defined as a range designed to handle 4 vehicles.

177 10 MULTIPURPOSE TRAINING RANGE (AC)**FAC: 1771****BFR Required: Y**

17710-1 **DEFINITION.** A Multipurpose Training Range is designed to meet the training and qualification requirements for the crews, teams and sections of combat units. This range is used to train and test armor, infantry, and aviation crews and sections on the skills necessary to detect, identify, engage, and defeat stationary and moving armor and infantry targets in a tactical array. Targets are not fully automated and/or the scenarios are not computer driven or scored. LN is defined as a range to support training for 2 vehicles.

177 11 AUTOMATED MULTIPURPOSE TRAINING RANGE (AC)**FAC: 1771****BFR Required: Y**

17711-1 **DEFINITION.** An Automated Multipurpose Training Range is specifically designed to satisfy the training and qualification requirements for the crews, teams and sections of combat units. This range supports dismounted infantry squad tactical live-fire operations either independently of, or simultaneously with supporting vehicles. This range is used to train and test armor, infantry, and aviation teams, crews and sections on the skills necessary to detect, identify, engage, and defeat stationary and moving armor and infantry targets in a tactical array. All targets are fully automated and the event specific targets scenario is computer driven and scored from the range operations center. LN is defined as a range to support training for 2 vehicles.

177 20 TANK/FIGHTING VEHICLE PLATOON BATTLE RUN (AC)**FAC: 1772****BFR Required: Y**

17720-1 **DEFINITION.** A Tank/Fighting Vehicle Platoon Battle Run is designed to meet the training and qualification requirements for platoons of armor and infantry units. This range is used to train and test armor and infantry platoons and sections on the skills necessary to detect, identify, engage, and defeat stationary and moving armor and infantry targets in a tactical array. Targets are not fully automated and/or the scenarios are not computer driven or scored. EA is defined as a range area to support training of platoon-sized units up to six vehicles.

177 21 TANK/FIGHTING VEHICLE MULTIPURPOSE RANGE COMPLEX, LIGHT, AUTOMATED (AC)**FAC: 1772****BFR Required: Y**

17721-1 **DEFINITION.** A Tank/Fighting Vehicle Multipurpose Range Complex, Light, Automated, is a complex designed to meet the training and qualification requirements for platoons of light and mechanized infantry, armor, and aviation units. This complex is used to train and test infantry, armor, and aviation platoons, sections, teams and crews on the skills necessary to detect, identify, engage, and defeat stationary and moving armor and infantry targets in a tactical array. All targets are fully automated and the event specific target scenario is computer driven and scored from the range operations center. EA is defined as a range area to support training of platoon-sized units up to six vehicles.

177 22 TANK/FIGHTING VEHICLE MULTIPURPOSE RANGE COMPLEX, HEAVY, AUTOMATED (AC)**FAC: 1772****BFR Required: Y**

17722-1 **DEFINITION.** A Tank/Fighting Vehicle Multipurpose Range Complex, Heavy, Automated, is a complex specifically designed to satisfy the training and qualification requirements for the crews and platoons of armor, infantry and aviation units. This complex supports dismounted infantry squad tactical live-fire operations either independently of, or simultaneously with supporting vehicles. This range is used to train and test armor, infantry, and aviation platoons, sections, teams and crews on the skills necessary to detect, identify, engage, and defeat stationary and moving armor and infantry targets in a tactical array. All targets are fully automated and the event specific targets scenario is computer driven and scored from the range operations center. When range can be used for both heavy and light purposes, it will be classified under this Category Code. EA is defined as a range area to support training of platoon-sized units up to six vehicles.

177 30 FIRE AND MOVEMENT RANGE (AC)**FAC: 1773****BFR Required: Y**

17730-1 **DEFINITION.** A Fire and Movement Range is designed for training individual and buddy/team fire and movement techniques. The team negotiates maneuver utilizing cover and concealment techniques. Targets are not fully automated and/or the scenarios are not computer driven or scored. LN is defined as the path or trails to support training for two persons.

177 40 SQUAD DEFENSE RANGE (AC)**FAC: 1774****BFR Required: Y**

17740-1 **DEFINITION.** A Squad Defense Range is designed for training individuals and squads on defensive engagement techniques and mutually supporting fires. This range is used to train personnel on the skills necessary to designate sectors of fire, identify, and provide suppressive fire on stationary infantry targets. All targets are fully automated and the event specific target scenario is computer driven and scored from the range operations center. EA is defined as a range area to support training for a squad-sized unit.

177 50 INFANTRY SQUAD BATTLE COURSE (AC)**FAC: 1775****BFR Required: Y**

17750-1 **DEFINITION.** An Infantry Squad Battle Course is designed for the training and qualification requirements of teams and squads on individual and collective tactics, techniques, and procedures and employment in tactical situations. This complex is used to train and test teams and squads on the skills necessary to conduct tactical movement techniques, detect, identify, engage, and defeat stationary and moving armor and infantry targets in a tactical array. Targets are not fully automated and/or the scenarios are not computer driven or scored. EA is defined as a range area to support training of squad and platoon sized units.

177 51 AUTOMATED INFANTRY SQUAD BATTLE COURSE (AC)**FAC: 1775****BFR Required: Y**

17751-1 **DEFINITION.** An Automated Infantry Squad Battle Course is designed for the training and qualification requirements of teams and squads on individual and collective tactics, techniques and procedures and employment in tactical situations. This complex is used to train and test teams and squads on the skills necessary to conduct tactical movement techniques, detect, identify, engage, and defeat stationary and moving armor and infantry targets in a tactical array. All targets are fully automated and the event specific target scenario is computer driven and scored from the range operations center. EA is defined as a range area to support training of squad and platoon sized units.

177 52 INFANTRY PLATOON BATTLE COURSE (AC)**FAC: 1775****BFR Required: Y**

17752-1 **DEFINITION.** An Infantry Platoon Battle Course is designed for the training and qualification requirements of infantry platoons, either mounted or dismounted, on movement techniques and operations. This complex is used to train and test platoons on the skills necessary to conduct tactical movement techniques, detect, identify, engage, and defeat stationary and moving armor and infantry targets in a tactical array. Targets are not fully automated and/or the scenarios are not computer driven or scored. EA is defined as a range area to support training of squad and platoon sized units.

177 53 AUTOMATED INFANTRY PLATOON BATTLE COURSE (AC)**FAC: 1775****BFR Required: Y**

17753-1 **DEFINITION.** An Automated Infantry Platoon Battle Course is designed for the training and qualification requirements of infantry platoons, either mounted or dismounted, on movement techniques and operations. This complex is used to train and test platoons on the skills necessary to conduct tactical movement techniques, detect, identify, engage, and defeat stationary and moving armor and infantry targets in a tactical array. All targets are fully automated and

the event specific target scenario is computer driven and scored from the range operations center. EA is defined as a range area to support training of squad and platoon sized units.

177 60 MOUT ASSAULT COURSE (MAC) (AC)

FAC: 1776

BFR Required: Y

17760-1 **DEFINITION.** A MOUT Assault Course is a facility for low-level collective training using live fire or MILES. This facility is used for training specific tasks before training on unit proficiency MOUT sites or Combat in Cities facility, carried under Category Code 179 61. Targets are not fully automated and/or the scenarios are not computer driven or scored. EA is defined as a range area to support training of platoon-sized units.

178 10 LIVE HAND GRENADE RANGE (AC)

FAC: 1781

BFR Required: Y

17810-1 **DEFINITION.** A Live Hand Grenade Range is designed to satisfy the training requirement of throwing live fragmentation grenades. This range familiarizes soldiers with the effects of live fragmentation grenades. No automation is required for this facility. Count each throwing location as one FP.

178 20 ENGINEER QUALIFICATION RANGE, NON-STANDARDIZED (AC)

FAC: 1782

BFR Required: Y

17820-1 **DEFINITION.** An Engineer Qualification Range, Non-standardized, is designed to meet the training and qualification requirements for engineer and combat engineer crews. This range is used to train and test engineer crews on the skills necessary to zero and/or boresight weapons systems, identify, classify, and reduce obstacles. Targets are not fully automated and/or the scenarios are not computer driven or scored. Count each firing position on the stationary firing line as one FP. If a stationary firing line does not exist, then count each obstacle clearing station as one FP.

178 21 ENGINEER QUALIFICATION RANGE, AUTOMATED / STANDARDIZED (AC)**FAC: 1782****BFR Required: Y**

17821-1 **DEFINITION.** An Engineer Qualification Range, Automated/Standardized, is designed for the training and qualification requirements of engineer and combat engineer crews. This range is used to train and test engineer Crews on the skills necessary to zero and / or boresight weapons systems, identify, classify, and reduce obstacles. All targets are fully automated and the event specific target scenario is computer driven and scored from the range operations center. Count each firing position on the stationary firing line as one FP. If a stationary firing line does not exist, then count each obstacle clearing station as one FP.

178 30 LIGHT DEMOLITION RANGE (AC)**FAC: 1783****BFR Required: Y**

17830-1 **DEFINITION.** A Light Demolition Range is designed for the training and qualification of employing explosives and demolition charges. This range is used to train personnel on the proper techniques of wire, minefield and concrete obstacle breaching, timber and steel cutting, road cratering, and explosive demolition. No automation is required for this facility. Count each prepared station as one FP. Planning and scoping this function should consider user requirements and explosive safety criteria.

179 TRAINING FACILITIES OTHER THAN BUILDINGS

179-1 This basic category includes requirements for weapons ranges, training courses and mockups, training pools/tanks, and parade and drill fields, but it does not include expendable targets.

179 01 BAYONET ASSAULT COURSE (AC)**FAC: 1790****BFR Required: Y**

17901-1 **DEFINITION.** A Bayonet Assault Course is designed for training assault techniques with a rifle and bayonet. These techniques are applied through a series of obstacles. This facility requires no automation. Report the number of FP as the number of prepared paths or set of targets in a standard path to be used in training.

179 02 TARGET DETECTION (TD) RANGE, NON-FIRING**FAC: 1790****BFR Required: Y**

17902-1 **DEFINITION.** A Target Detection Range, Non-Firing, is a non-firing range to teach soldiers how to detect personnel on the battlefield under varying degrees of concealment and visibility. No automation is required for this range.

179 03 HAND TO HAND COMBAT PIT**FAC: 1790****BFR Required: Y**

17903-1 **DEFINITION.** A Hand-to-Hand Combat Pit is a structure containing a circle of sand or sawdust for training in hand-to-hand fighting.

179 04 PRISONER OF WAR TRAINING AREA**FAC: 1790****BFR Required: Y**

17904-1 **DEFINITION.** A Prisoner of War Training Area is typically an area fenced in with barbed wire and with guard towers used for the training of personnel in the handling of prisoners-of-war. The facility may also be used for the training of personnel in a simulated POW environment.

179 05 MINE WARFARE AREA (AC)**FAC: 1790****BFR Required: Y**

17905-1 **DEFINITION.** A Mine Warfare Area is a cleared area for training in the placement, arming, disarming, and detection of vehicle and anti-personnel mines using non-explosive training material.

179 06 WHEELED VEHICLE DRIVERS COURSE (AC)**FAC: 1790****BFR Required: Y**

17906-1 **DEFINITION.** A Wheeled Vehicle Drivers Course is for teaching basic driving skills, and for practice in four-wheel drive situations, parking, and backing up.

179 07 TRACKED VEHICLE DRIVERS COURSE (AC)**FAC: 1790****BFR Required: Y**

17907-1 **DEFINITION.** A Tracked Vehicle Drivers Course is an area to teach the basic driving skills of steering and gear shifting on a level course. The facility may also contain a hilly course for developing advanced tracked vehicle driving skills such as turning on slopes and negotiating steep grades.

179 08 AMPHIBIOUS VEHICLE TRAINING AREA (AC)**FAC: 1790****BFR Required: Y**

17908-1 **DEFINITION.** An Amphibious Vehicle Training Area contains sand or is close to a beach for training military personnel on unique driving, technical and tactical tasks associated with amphibious operations.

179 09 SHIP LOADING AND UNLOADING MOCKUP (SF)**FAC: 1732****BFR Required: Y**

17909-1 **DEFINITION.** A mockup of a ship used for training personnel in ship loading and off-loading. Training area can also include negotiating cargo nets used during amphibious operations and operations at dockside.

179 10 AIRCRAFT GUNNERY, BOMBING, AND ROCKET RANGES (EA)**FAC: 1793****BFR Required: N**

17910-1 **DEFINITION.** Aircraft Gunnery, Bombing and Rocket Ranges (Aircraft Weapons Ranges) provide air crews with operating areas for the development of proficiency in gunnery, bombing, rocketry, missile delivery, strafing, and mine laying. Ranges should generally be within 100 miles of the supporting air installation. The following criteria are not absolute as far as requirements are concerned; however, any plans to deviate from these criteria shall be referred to the Naval Air Systems Command.

17910-1.1 **Air-to-Air Weapons Ranges.** The Air-to-Air Weapons Ranges are Gunnery and Missile Ranges and should, if possible, be over water. The minimum surface impact areas and coincident restricted airspaces, whose minimum altitude is based on the characteristics of the using aircraft, are as follows:

- Gunnery Range - 23 nautical miles by 50 nautical miles.

- Rocket and Missile Ranges - 50 nautical miles square.

17910-1.2 **Air-to-Ground Ranges.** The Air-to-Ground Ranges are for training in strafing, high-altitude level bombing, loft bombing, close air support, aerial mining, and missile delivery. Communications are required between ground stations and between target controller and aircraft at these ranges. See Table 179-10 for specific surface impact areas, minimum restricted airspace, and other data applicable to air-to-ground ranges.

The following information for Air-to-Ground Weapons Ranges is provided in addition to that contained in Table 17910-1.

- **Strafing Range.** A strafing range is for air-to-ground gunnery proficiency training in low-altitude strafing firing 20-millimeter and possibly 30-millimeter ammunition. Targets may be panels or may simulate aircraft, gun emplacements, truck convoys, etc., and may be automatic recording targets.
- **High-Altitude Level-Bombing Range.** The high altitude level bombing range provides training in high-speed, high-altitude, level-altitude bomb releases. The center of the target is visible from 10 nautical miles at 50,000 feet. Offset bombing exercises are also conducted.
- **Multipurpose Target Range.** The multipurpose range is used for training in conventional dive bombing, high-altitude dive bombing, glide bombing, strafing, and rocketry (excluding controlled air-to-ground missiles). Inert training weapons with small charges are used to facilitate spotting.
- **Loft Bombing Range.** The loft bombing range is a highly instrumented land range for practice bombing with simulated nuclear weapons. A minimum altitude approach is used; bomb release maneuvers practiced include loft, toss, and over-the-shoulder techniques providing training in rapid recovery and escape from atomic-weapon effects, detection, and retaliatory ground fire.

The restricted airspace includes a 5-nautical-mile radius from the target center extending upward from the surface to 24,000 feet above the target and multiple-approach corridors extending 25 miles from target center. A 6-nautical-mile corridor width is required when alternate left or right escape maneuvers are performed. Clearance above the corridors is 3,000 feet for the first 10 nautical miles of the approach, 5,000 feet for the next 8 nautical miles, and 9,000 feet for the remaining 2 nautical miles to the airspace cylinder around the target center. The initial point of aim is at 50,000 feet from the target center which must be visible from an aircraft at

100 feet altitude. Instrumentation along the primary approach to the target provides instantaneous speed measurements, photo coverage, and profile and escape information.

- Close Air Support and Combat Training Area. The close air support and combat training area is planned for training with live ordnance, shapes, napalm, and air-to-ground missiles.
- Aerial Mining Range. The aerial mining range is planned for training in low-altitude and high-altitude mining. The restricted airspace is generally parallel to an adjacent irregular coastline with readily identifiable landmarks.
- Guided Missile Range. The air-to-ground guided missile target range is used for training in controlled air-to-ground missiles.

17910-2 The restricted airspace is 24,000 feet in height and consists of a rectangular- shaped primary line of approach 4 nautical miles wide by 5 nautical miles long starting at a point 15 nautical miles from the center of the impact area. The total length of the range is 20 nautical miles.

Table 17910-1
Basic Requirement for Air-to-Ground Ranges

Range	Minimum surface impact area (nautical miles)	Minimum restricted airspace (nautical miles)	Maximum restricted airspace (feet)	Control and spotting towers Note (2)	Target illumination for night operations
A. Strafing	1 x ½	Radius 5	10,000	1 Control	Yes
B. High altitude level bombing	Radius 3	Radius 5	Unlimited	1 Control Note (3)	Yes
C. Multipurpose target	Radius 1-1/2	Radius 5	Note (1)	Note (4)	Yes
D. Loft bombing	Radius 1-1/2	Radius 5 Length 30 Note (8)	24,000 Note (8)	Note (5)	Yes
E. Close air support and combat training area	16 x 20	Radius 25	Note (1)	Note (6)	Yes
F. Aerial mining	3 x 8	3 x 8	Note (1)	Note (4)	No
G. Guided missile	8 x 8	Radius 5 Length 20 Note (8)	24,000	Note (6) and (7)	Yes

Notes:

- (1) The restricted airspace extends vertically to the maximum altitude required by the using aircraft.
- (2) See Operational Tower, Category Code 179 35.
- (3) Two spotting towers also are required to provide accurate three-dimensional rake information where remote spotting devices are not used.
- (4) One control and two spotting towers are required to provide accurate three-dimensional rake information.
- (5) One control and three spotting towers are required.
- (6) One control tower and two spotting towers at each designated target site are required.
- (7) Towers are required only at ranges where self-guiding missiles are fired.
- (8) See detailed airspace description in text.

179 11 AIR TRANSPORT MOCKUP (SY)**FAC: 8526****BFR Required: Y**

17911-1 **DEFINITION.** An Air Transport Mockup is a ramp and a platform structure used to simulate varying types of fixed- and rotary-wing aircraft. Structure allows loading, securing, and unloading of vehicles, equipment, and/or personnel.

179 12 ELEVATED TRAINING TOWER/PLATFORM**FAC: 1734****BFR Required: Y**

17912-1 **DEFINITION.** A Elevated Training Tower/Platform is a structure consisting of platforms built above a sandy landing area to train future paratroopers proper aircraft exiting and landing techniques. It can consist of a canopy area and platform, a mockup of an aircraft door to train future paratroopers the proper exiting techniques from an aircraft as well as for parachute landing falls that simulates the deceleration experienced during a parachute opening.

179 13 SUSPENDED HARNESS MOCKUP

CCN deleted in FY19. Assets have been consolidated into CCN 179 12.

179 14 MOCKUP JUMP TOWER

CCN deleted in FY19. Assets have been consolidated into CCN 179 12.

179 15 UNDERWATER FORDING SITE

CCN deleted in FY19.

179 16 COMBAT TRAIL (AC)**FAC: 1790****BFR Required: Y**

17916-1 **DEFINITION.** A Combat Trail is a training site used for various types of proficiency and sustainment training by rotation through different stations in a round-robin scenario. Types of training can include nuclear, Biological, and Chemical (NBC) and common task training. This site is separate from other training areas and sites.

179 17 RAPPPELLING TRAINING AREA (EA)**FAC: 1790****BFR Required: Y**

17917-1 **DEFINITION.** A Rappelling Training Area is an area that includes at least one structure used to practice rappelling (rope descent). The training area may also include modified towers for training in helicopter rappels.

179 18 AIRFIELD DEMOLITION RANGE (ADR) (SY)**FAC: 1164****BFR Required: Y**

17918-1 **DEFINITION.** An area for training in the placement, clearing, compaction, repair, and grading of fill and construction of drainage structures for airfields. Steel mats or other non-bituminous mats may be utilized. If the airfield is actually used by aircraft, it should be inventoried as an unpaved airfield facility using appropriate 100 series Category Codes.

179 19 TIMBER BRIDGE AREA**FAC: 1790****BFR Required: Y**

17919-1 **DEFINITION.** A Timber Bridge Area is a cleared area beside a ditch or ravine for engineer units to practice building timber bridges.

179 20 PANEL BRIDGE AREA**FAC: 1790****BFR Required: Y**

17920-1 **DEFINITION.** A Panel Bridge Area is a cleared area beside a creek or ravine for engineer units to practice building panel bridges.

179 22 FLOATING BRIDGE SITE**FAC: 1790****BFR Required: Y**

17922-1 **DEFINITION.** A Floating Bridge Site is a cleared riverbank area for engineer units to practice fording water obstacles and erection and retrieval of floating bridging equipment.

179 24 WATER SUPPLY TRAINING AREA (EA)**FAC: 1790****BFR Required: Y**

17924-1 **DEFINITION.** A Water Supply Training Area is partially improved land for performing water purification and storage operations. It should be located on a flowing stream with firm banks and all-weather access roads.

179 25 AIRFIELD SITE SELECTION TRAINING AREA (AC)**FAC: 1790****BFR Required: Y**

17925-1 **DEFINITION.** An Airfield Site Selection Training Area is cleared land used to train soldiers in the fundamentals of selecting and securing a site suitable for takeoffs and parking of rotary-wing aircraft.

179 26 AERIAL GUNNERY RANGE (AC)**FAC: 1792****BFR Required: Y**

17926-1 **DEFINITION.** An Aerial Gunnery Range is designed to support the training and qualification requirements of helicopter gunnery. This range is used to train and test helicopter crews on the skills necessary to detect, identify, engage, and hit stationary armor and infantry targets in a tactical array. This range does not require automation but does require surveillance of the target area.

179 30 SURFACE PROJECTILE RANGE (EA)**FAC: 1767****BFR Required: N**

17930-1 **DEFINITION.** This code is for ranges supporting surface-launched projectiles as opposed to ranges for air-launched projectiles which are coded as Category Code 179 10. Criteria are not presently available for surface projectile range requirements.

179 31 MEDIUM HEAVY EQUIPMENT TRAINING AREA (AC)**FAC: 1790****BFR Required: Y**

17931-1 **DEFINITION.** A Medium Heavy Equipment Training Area is an unimproved area for training in placement, compaction, and grading of fill, and training in construction of drainage structures.

179 32 DECONTAMINATION TRAINING SITE (AC)**FAC: 1790****BFR Required: Y**

17932-1 **DEFINITION.** A Decontamination Training Site is an area consisting of a pit filled with rock with an attached rock-filled sump to a drain bed. This structure is used primarily for vehicle decontamination training.

179 33 POL TRAINING AREA (AC)**FAC: 1790****BFR Required: Y**

17933-1 **DEFINITION.** A POL Training Area is a materials handling area for training personnel in the proper handling of petroleum, oils, and lubricants. Also used for assembly and training in various POL storage and distribution systems.

179 35 WEAPONS RANGE OPERATIONS TOWER (EA)**FAC: 1734****BFR Required: N**

17935-1 **DEFINITION.** Range operations towers are used at gunnery, bombing, and rocket ranges to provide an unobstructed view of target areas for purposes of control and spotting impacts. For the tower requirements associated with the various ranges, see Category Code 179 10 (Table 179-10). The two types of weapons range operations tower are:

17935-1.1 The control range operations tower (control tower) has a gross area of 1,428 square feet and provides for the radio control of all range activities, including the scoring of training missions both visually and electronically.

17935-1.2 The spotting range operations tower (spotting tower) has a gross area of 100 square feet and is a secondary observation point to provide for visual scoring.

179 36 CLOSE AIR SUPPORT RANGE (AC)**FAC: 1793****BFR Required: N**

17936-1 **DEFINITION.** A Close Air Support Range is designed to support the training and qualification requirements of close air support aircraft. This range is used to train and test aircraft crews on the skills necessary to provide air support to ground forces under varying conditions. This range does not require automation but does require surveillance of the target area.

179 37 AERIAL BOMBING RANGE (AC)**FAC: 1793****BFR Required: N**

17937-1 **DEFINITION.** An Aerial Bombing Range is designed to support the training and qualification requirements for fixed-wing aircraft dropping their ordnance. This range is used to train and test aircraft crews on the skills necessary to detect and suppress enemy targets in a tactical array. This range does not require automation but does require surveillance of the target area.

179 40 SMALL ARMS RANGE - OUTDOOR (EA)**FAC: 1750****BFR Required: Y**

17940-1 **DEFINITION.** A small arms range provides an area for training in the use of pistols, small caliber rifles, and small caliber machine guns. Ranges must be available all year to provide continual training and retraining for personnel who must be proficient in the use of small arms. If feasible, a small-arms range should provide training facilities for all military services within the area.

17940-2 The capacity of existing ranges or new requirements can be determined by:

17940-2.1 Identifying the number of personnel to be trained.

17940-2.2 Establishing the number and size of training sessions.

17940-2.3 Determining the number of hours per session and scheduling training over an annual basis.

17940-2.4 Calculating the required number of firing points based upon efficient arrangement of the size and schedules of the training groups.

17940-3 In developing requirements, the base number of training days less holidays and weekends is 242 days. However, ranges require maintenance and periods of recovery for flora and fauna and are often unusable during

periods of severe weather or peculiar local limitations. The basic number of training days can be further reduced to 180 days based on local conditions.

17940-4 For certain types of small arms and where prevailing weather conditions seriously interfere with scheduling of training, an indoor range (Code 171 50) may be planned.

179 41 AIR DEFENSE MISSILE FIRING RANGE (AC)

FAC: 1794

BFR Required: Y

17941-1 **DEFINITION.** An Air Defense Missile Firing Range is designed to meet training and qualification requirements of air defense (LAAD/Stinger) units. This range is used to train and test crews on the skills necessary to employ ground to air anti-aircraft missiles against ballistic aerial target systems (BATS).

179 45 TRAINING MOCK-UPS (EA)

FAC: 1790

BFR Required: Y

17945-1 **DEFINITION.** This code includes mockup structures representing all or parts of ships, aircraft, tanks, or buildings for training personnel in skills such as disaster control, firefighting, and equipment handling.

179 50 TRAINING COURSE (AC)

FAC: 1790

BFR Required: N

17950-1 **DEFINITION.** This code includes areas designated for personnel training in various skills under actual operational conditions. Table 17950-1 outlines the facilities of this group and approximate requirements.

**Table 17950-1
Training Course Criteria**

Type of Course	Approximate Size	Preferred Terrain	Typical Improvements
Obstacle	2 acres	Flat	Obstacles, drainage
Combat techniques, guerrilla warfare, counterinsurgency	100 acres	Rough, heavy vegetation	Provisional mess hall and toilets where justified
Weapons ranges	See Code 179-10		

Type of Course	Approximate Size	Preferred Terrain	Typical Improvements
Disaster control, firefighting, etc.	2 acres	Flat	Training mockups
Field engineering surveying practice	2 acres	Rolling	None
Building construction practice	2 acres	Flat	1,200 square yards of paved area
Construction equipment operations	20 acres	Rolling, no vegetation	None
Vehicle safety, driver testing	6 acres	Flat	Pave area, course markers
Swimming, survival	See Code 179-55		

179 51 UNENCLOSED FIRE FIGHTER TRAINER (SF)**FAC: 1795****BFR Required: Y**

17951-1 **DEFINITION.** A Fire Fighting and Rescue Training Area is an open area or structure consisting of a mockup of a multistory building, aircraft, or vehicle for training in fire containment, ladder use, escape, and rescue from buildings.

179 53 ENCLOSED FIRE FIGHTER TRAINER FACILITY (SF)**FAC: 1726****BFR Required: Y**

17953-1 **DEFINITION.** This is an enclosed facility that houses interior and exterior mockups of areas within a surface ship, submarine, or multistory building for live firefighting and rescue training.

179 54 DAMAGE CONTROL (WET) TRAINER (SF)**FAC: 1724****BFR Required: Y**

17954-1 **DEFINITION.** This category code is used to capture facilities used in the training of shipboard flooding countermeasures. Facilities include below-deck shipboard mockups with water deluge systems, observation decks, training classrooms, administrative spaces, and water deluge pumps, piping, and drainage systems.

179 55 COMBAT TRAINING POOL/TANK (EA)**FAC: 1725****BFR Required: Y**

17955-1 **DEFINITION.** A combat training pool/tank is planned for instructions in swimming and survival under combat conditions. The swimming pool/tank may be provided only as required for training purposes, normally on the following basis: for each increment of 5,000 men to be trained, one swimming pool; pool area not to exceed 13,000 square feet. If survival training is required at installations having less than 5,000 assigned strength, one swimming pool of appropriate size may be provided, but not to exceed 13,000 square feet in pool area. Outdoor pools may be provided where feasible.

179 60 PARADE AND DRILL FIELD (AC)**FAC: 1745****BFR Required: N**

17960-1 **DEFINITION.** This facility provides space for formation drills, parade and review functions, and honor ceremonies. Such a field may be planned for stations having independent command functions. The size of the field is computed on the basis of 1 acre per 125 men, total planned military strength. Surface will be turf where feasible and will be stabilized where climate and other conditions dictate. A reviewing stand may be planned with a capacity based on 5 percent of the total officer strength.

179 61 COMBAT IN CITIES FACILITY (AC)**FAC: 1790****BFR Required: Y**

17961-1 **DEFINITION.** A Combat in Cities Facility is a non-standard training facility that typically includes the buildings, roads, and sidewalks normally found in an urban environment, and which is used to train and sustain unit proficiency in an urban environment. This facility is used to train urban-type operations when a standard CACTF is not available. No automation is required for this facility.

179 62 MOUT COLLECTIVE TRAINING FACILITY (SMALL) (AC)**FAC: 1790****BFR Required: Y**

17962-1 **DEFINITION.** A MOUT Collective Training Facility (small) is designed to meet the training requirements of an infantry company-sized unit in an urban environment. This structure contains 24 buildings or less and is used to train unit collective tasks associated with urban terrain. Targets are not fully automated and/or the scenarios are not computer driven or scored.

179 63 MOUT COLLECTIVE TRAINING FACILITY (LARGE) (AC)**FAC: 1796****BFR Required: Y**

17963-1 **DEFINITION.** A MOUT Collective Training Facility (large) is designed to meet the training requirements of an infantry battalion-sized unit in an urban environment. This structure contains more than 24 buildings and is used to train unit collective tasks associated with urban terrain. Targets are not fully automated and/or the scenarios are not computer driven or scored.

179 70 RADAR BOMB SCORING FACILITY (EA)**FAC: 1790****BFR Required: N**

17970-1 **DEFINITION.** A Radar Bomb Scoring Facility (RBS) is used to measure, electronically, aircraft simulated-bombing results and to produce graphic flight path tracking data and other pertinent aircraft target scoring information. An RBS facility is available as a self-contained trailer-mounted facility. The mobile RBS equipment includes an operations trailer, acquisition radar, tracking radar, maintenance and spare parts trailer, and power trailer. A permanent power supply at the range eliminates the power trailer requirement. Criteria are not presently available for a fixed RBS System which would utilize permanent structures. RBS facilities are provided for selected aircraft ranges as determined by CNIC.

179 71 ELECTRONIC WARFARE TRAINING RANGE (EA)**FAC: 1790****BFR Required: N**

17971-1 Criteria for the Electronic Warfare Training Range are not currently available.

179 72 UNDERWATER TRACKING TRAINING RANGE (EA)**FAC: 1790****BFR Required: Y**

17972-1 **DEFINITION.** The underwater tracking range is used primarily to support surface and subsurface weapon system accuracy trials and development, test, and evaluation projects. No planning factors are currently available for this facility. Planning factors, standards, and guides for computing requirements for facilities under this category are excluded from this publication because of the special provisions and variances in the application of criteria for planning underwater tracking ranges. In the absence of specific criteria, the quantitative requirements for the range facilities should be determined on an individual basis based on the experience and knowledge of the activity involved and the appropriate Systems Commands.

179 81 INFILTRATION COURSE (AC)

FAC: 1798

BFR Required: Y

17981-1 **DEFINITION.** An Infiltration Course is designed for training individual infiltration and combat movement techniques and then executing them while subject to live fire. No automation is required for this facility. Count each path or trail for a single Marine as one FP.

179 91 CONFIDENCE COURSE (AC)

FAC: 1799

BFR Required: Y

17991-1 **DEFINITION.** A Confidence Course is designed for developing individual soldier confidence and strength through a series of obstacles. No automation is required for this facility. Count each complete course as one EA.

179 92 OBSTACLE COURSE (AC)

FAC: 1799

BFR Required: Y

17992-1 **DEFINITION.** An Obstacle Course is a facility containing numerous obstacles designed for developing and measuring individual soldier speed, agility, and coordination utilizing various obstacles in an effort to reach the objective. No automation is required for this facility.